

# IDS-409F Managed Industrial Ethernet Switch with Fiber

## 9 port Compact DIN Rail Switch



- 10/100/1000Base-T (RJ45) ports for Gigabit and Fast Ethernet devices
- 100Base-X SC/ST fiber ports
- IP Manageability, VLAN and resiliency management
- Digital inputs for generation of alerts
- Compact, corrosion resistant case attaches to a standard DIN Rail
- Redundant dual power input 12/24/48 VDC, 24 VAC
- Out-of-band management via RJ45 or USB serial ports
- Programmable Controller safety and Hazardous Location Certification
- -40 to 75°C industrial operating temperature (XT Models)

The **IDS-409F** is a **9 port Managed Ethernet Switch** that can operate in **industrial environments** providing advanced performance and enabling **real-time deterministic network operation**. Choose any combination of **10/100/1000-Base-T Ethernet copper ports** and **100Base-X fiber ports** to meet the needs of your environment.

In addition to extending links over greater distances, **utilizing fiber is critical** in environments where **high levels of electromagnetic interference (EMI)** is a common phenomenon, like industrial plants. This interference can cause data corruption over copper-based Ethernet links. However, data transmitted over fiber optic cable is completely immune to this type of noise ensuring optimal data transmission across the plant floor.

Perle **Industrial-grade Ethernet Switches** are designed to stand up to **extreme temperatures, surges, vibrations, and shocks** found in **industrial automation, government, military, oil and gas, mining and outdoor applications**.

**With over 78 models**, the Perle IDS-409F offers a choice of connectors, fiber types, temperature support and operating distances.

Simple **Plug and Play** installation to get your Ethernet devices networked immediately is available with Perle's **Fast Setup feature**. **CCNA** (Cisco Certified Network Associate) and **CCNP** (Cisco Certified Network Professional) trained engineers will appreciate the familiar **Command Line Interface (CLI)** via in-band Telnet or the out-of-band serial console port.

The **IDS-409F** supports a comprehensive set of management functions, such as **P-Ring, management VLAN, QoS, RMON, N:1 port mirroring** and **local alert log**. In addition, the switch can be **managed with an IPv6 address**.

All IDS-409F models, are **rugged fan-less switches** that are hardened to provide superior reliability in **-10 to 60°C**. In addition, **every component** on every **industrial (XT) model** has been **designed and tested** to handle operating temperatures between **-40 and 75°C**.

All Perle Industrial Ethernet Switches only use **high-end components** from the **leading chip manufacturers** to ensure the highest level of **durability and reliability**. In addition, all units have a corrosion resistance aluminum case and dual redundant power input with reverse polarity and overload protection.

For **over 35 years** Perle has been **designing industrial hardware**. This expertise was used to design the **toughest Ethernet switches on the market**.

## IDS-409F Industrial Managed DIN Rail Switch Features

### Simple deployment

Zero-touch discovery using Dynamic Host Control Protocol (DHCP), Perle's "Fast Setup" for first time installation, provides simple deployment in Ethernet environments

### Resiliency

- STP and RSTP protocols for fast recovery
- Perle's **P-Ring protocol** for fast convergence in ring topologies
- Link Standby is a link recovery feature for two links that provides a simple alternative to spanning tree protocols for link redundancy

### Manageability

- Web Device Manager, Telnet, SNMP and Perle's **PerleView** NMS for centralized management
- In-band management via RJ45 or USB serial port
- Use an IPv4 or IPv6 address
- Removable MicroSD flash for configuration files and firmware backup and restoration

### Rugged design for harsh environments

- Corrosion resistant case
- Programmable Controller Safety certified
- Certified for hazardous locations
- Extended industrial temperature models

### Reliable operation

- Fan-less, no moving parts
- Dual power input. Connect to separate power sources for redundancy.
  - Reverse polarity protection
  - Overload current protection
- Handles vibration and shock conditions found in industrial environments

## Real-time Ethernet performance

- Fast wire-speed, store and forward switching
- Auto-sensing for speed and duplex
- Auto-mdi/mdix-crossover works with straight and crossover cables

Performance Features	
Port Auto-sensing	Auto-sensing of port speed and auto-negotiation of duplex on all switch ports for optimizing bandwidth
Auto MDI/MDIX	Medium-dependent interface crossover (Auto-MDIX) capability on 10/100 and 10/100/1000 mbps interfaces that enables the interface to automatically detect the required cable type (straight thru or crossover) and to configure the connection appropriately
802.3x flow control	IEEE 802.3x flow control on all ports. (The switch does not initiate pause frames)
Storm Control	Storm control prevents traffic on a LAN from being disrupted by a broadcast, multicast, or unicast storm on one of the physical interfaces. A LAN storm occurs when packets flood the LAN, creating excessive traffic and degrading network performance. Storm Control enables limits to be placed on broadcast, multicast and unicast traffic
Static MAC Addressing	This feature enables the manual configuration of the MAC addresses on a per port basis. Flooding is prevented by retaining MAC entries across a reboot of the switch.
Port Blocking	Port Blocking provides the ability to block the flooding of unknown layer 2 unicast and multicast traffic on an Interface
IPV4 IGMP Snooping	<p>Internet Group Management Protocol (IGMP) constrains the flooding of multicast traffic by dynamically configuring Layer 2 interfaces so that multicast traffic is forwarded to only those interfaces associated with IP multicast devices.</p> <p>IGMPv1, v2, v3, IGMP snooping querier mode, IGMP report suppression, topology change notification and robustness variable features are supported</p>

Port Quick Disconnect	In some network environments, it is desirable to move an Ethernet from one switch port to another and have the device come on-line quickly. The Port Quick Disconnect feature if enabled, provides an immediate age-out of the MAC addresses learned on the port when the port status changes from a link-up to a link-down state
<b>Manageability Features</b>	
Web Device Manager	The Perle Web Device Manager is an embedded Web based application that provides an easy to use browser interface for managing the switch. Unlike competitive products, Java applet technology is not required or used
Command Line Interface (CLI)	A familiar text-based Command Line Interface that is based on accepted industry standard syntax and structure. Ideal for CCNA and CCNP trained engineers, this interface is available via in-band Telnet or the out-band serial console port
SNMP	Manage the switch with an SNMP compatible management station that is running platforms such as HP Openview or Perle's PerleVIEW NMS. SNMP V1 and V2C
<b>PerleVIEW</b>	PerleVIEW is Perle's SNMP-based network management system that provides a view of the network with a large scale of Perle networking devices.
IPv6	Manage with an IPv4 or IPV6 address
DHCP Client Auto-Configuration	Automates configuration of switch information such as IP address, default gateway, hostname and Domain Name System (DNS) as well as TFTP server names. Firmware and configuration file locations are provided through options 54, 66, 67, 125 and 150
DHCP Relay	DHCP Relay is used for forwarding requests from DHCP clients when they are not on the same physical subnet. As a DHCP relay agent the switch operates as a Layer 3 device that forwards DHCP packets between clients and servers.

<b>DHCP Option 82 Insertion</b>	Normally used in metro or large enterprise deployments DHCP Option 82 insertion is used to provide additional information on “physical attachment” of the client. As per RFC 3046, option 82 enables additional pre-defined information to be inserted into the DHCP request packet (for DHCP Servers that support this option)
<b>LLDP</b>	LLDP-Link Layer Discovery Protocol as per IEEE 802.1AB is a neighbor discovery protocol that is used for network devices to advertise information about themselves to other devices on the network. This protocol runs over the data-link layer, which allows two systems running different network layer protocols to learn about each other (via TLVs – Type-Length-Value)
<b>File Download</b>	Firmware can be transferred via TFTP, HTTP or via insertion of a microSD card. Text-based files that can be created or edited by common text editors.
<b>Availability and Redundancy Features</b>	
<b>Spanning Tree Protocol (STP)</b>	IEEE 802.1D now incorporated in IEEE 802.1Q-2014, STP prevents bridge loops and the broadcast radiation that results from them.
<b>Rapid Spanning Tree Protocol (RSTP)</b>	Interoperable with STP, RSTP (IEEE 802.1w) takes advantage of point-to-point wiring and provides rapid convergence of the spanning tree. Reconfiguration of the spanning tree can occur in less than 1 second
<b>P-Ring</b>	P-Ring provides an easy to use method for configuring a ring network using standard spanning tree protocols.  Prevents a switch loop scenario in a ring topology.
<b>Link Standby</b>	A link recovery feature using a primary and backup link. Provides a simple alternative to spanning tree protocols for link redundancy
<b>VLAN Features</b>	
<b>VLAN Range</b>	Up to 256 VLANS across a VLAN ID range of 1 to 4000
<b>VLAN Interfaces</b>	Perle switches provide the ability to configure management VLAN interfaces. This enables network administrators to access the switch’s management interface from separate VLAN networks

<b>Quality of Service (QoS) and Class of Service (CoS) Features</b>	
Classification	IP ToS/DSCP and IEEE 802.1p CoS
Congestion Avoidance	Weighted Fair Queuing or Strict Queuing
Egress Queues and scheduling	<ul style="list-style-type: none"> <li>• 4 traffic class queues per port</li> <li>• output queue mapping</li> <li>• DSCP to output queue mapping</li> </ul>
<b>Monitoring Features</b>	
Port Mirroring	N:1 Port Mirroring is a method of monitoring network traffic. With port mirroring enabled, the switch sends a copy of one or more ports to a predefined destination port. Selection of Transmit, Receive frames or both can be made
RMON	RMON statistics provided for statistics, history, alarms and events for network monitoring and traffic analysis
Syslog	Facility for logging systems messages to an external SYSLOG server
Alert Log	Facility for logging systems messages locally
Traceroute	Layer 2 traceroute to identify the path that a frame takes from source to destination
Power Supply Monitoring	Provides the status of power supplies of the switch

<b>Alarm Processing</b>	<p>The switch can monitor global switch conditions as well as individual ports. These alarms can be configured to send messages to :</p> <ul style="list-style-type: none"> <li>• an internal log file</li> <li>• external Syslog server</li> <li>• SNMP trap server</li> <li>• An external alarm device such as a bell, light or other signaling device via the switch's built-in dry contact alarm relay</li> </ul> <p>Global Status Monitoring Alarms</p> <ul style="list-style-type: none"> <li>• Dual power supply alarm</li> </ul> <p>Port Status Monitoring Alarms</p> <ul style="list-style-type: none"> <li>• Link Fault Alarm (IE loss of signal)</li> <li>• Port not forwarding alarm</li> <li>• Port not operating alarm (failure upon start up tests)</li> <li>• FCS Bit error rate alarm</li> </ul>
<b>Alarm Relay</b>	<p>When enabled, energizes the built-alarm relay triggering an external alarm circuit such as a bell, light or other signaling device according to alarm conditions set</p>
<b>Management and Standards</b>	
<b>IEEE Standards</b>	<ul style="list-style-type: none"> <li>• IEEE 802.3 for 10Base-T</li> <li>• IEEE 802.3u for 100BaseT(X) and 100BaseX</li> <li>• IEEE 802.3ab for 1000Base-T</li> <li>• IEEE 802.3z for 1000BaseX</li> <li>• IEEE 802.3x for Flow Control</li> <li>• IEEE 802.1D-2004 for Spanning Tree Protocol</li> <li>• IEEE 802.1w for Rapid STP</li> <li>• IEEE 802.1Q for VLAN Tagging</li> <li>• IEEE 802.1p for Class of Service</li> <li>• IEEE 802.3ad for Port Trunk with LACP</li> <li>• IEEE 802.1AB LLDP</li> </ul>

## Hardware & Technical Specifications: IDS-409F Industrial Managed DIN Rail

## Switch

Power	
Dual Power Input	<p>Both inputs draw power simultaneously. If one power source fails, the other live source can, acting as a backup, supply enough power to meet the operational needs of the switch.</p> <ul style="list-style-type: none"> <li>• 12/24/48 VDC Nominal. (9.6 to 60 VDC)</li> <li>• 24 VAC Nominal (18 to 30 VAC)</li> </ul>
Power Connector	<ul style="list-style-type: none"> <li>• 4-Pin Removable Terminal Block.</li> <li>• Grounding screw on metal chassis</li> </ul>
Maximum Current Consumption @24 vDC	3 Fiber ports = 0.66 amps
Maximum Current Power @24 vDC	3 Fiber ports = 15.7 watts
Overload Current Protection	Fused overload current protection
Reverse polarity protection	The positive and negative inputs can be reversed providing safe and simple power connectivity.
Access Ports	
RJ45	<ul style="list-style-type: none"> <li>• 6 shielded RJ45 ports for 10/100/1000Base-T up to 100 meters (328 ft)</li> <li>• Auto-negotiation</li> <li>• Auto-MDI/MDIX-crossover for use with either crossover over straight-through cable types</li> <li>• Ethernet isolation 1500 V</li> </ul>
RJ45 Serial Console port	<ul style="list-style-type: none"> <li>• RJ45 DTE</li> <li>• Optional rolled and straight thru RJ45 cables and DB adapters are available</li> </ul>
USB Serial Console port	MicroUSB Type B female port for serial console management. Used as an alternative port for out of band management connections
Digital Inputs	Two Digital Inputs are provided that can be used for generation of alarms (SNMP trap, energizing of on-board Alarm Relay,etc)

Fast Ethernet Fiber ports	3 1000Base-x fiber port models Duplex SC or ST connector <ul style="list-style-type: none"> <li>• Multimode 50/125 or 62.5/125 micron fiber cable</li> <li>• Single mode 9/125 micron fiber cable</li> </ul> Simplex (BIDI, single strand) SC connector <ul style="list-style-type: none"> <li>• Multimode 50/125 or 62.5/125 micron fiber cable</li> <li>• Single mode 9/125 micron fiber cable</li> </ul> PC and UPC type patch cords supported.
Alarms	
Alarm Relay	<ul style="list-style-type: none"> <li>• NC (Normally Closed) or NO (Normally Open) dry contact.</li> <li>• 1A @ 24V</li> </ul>
Switch Properties	
Standards	<ul style="list-style-type: none"> <li>• IEEE 802.3 for 10Base-T</li> <li>• IEEE 802.3u for 100Base-TX and 100Base-FX</li> <li>• IEEE 802.3ab for 1000Base-T</li> <li>• IEEE 802.3x for Flow Control</li> </ul>
Processing Type	Store and Forward
MAC Address Table Size	8K
VLAN ID range	1 to 4000
IGMP groups	1024
Packet Buffer Memory	1 Mbit
Indicators	
Power	This LED is turned on when the appropriate level of voltage is applied to one or both of the power inputs
System	Indicates whether the switch O/S is operating normally
RJ45 Ethernet	These integrated colored LEDs indicate link, activity and speed for each port.

Fiber Link	Fiber link LED indicates Link and Data Activity
Alarm	The alarm LED (Red) will be turned on under alarm conditions
P-Ring Master LED	Status of the P-Ring Master
Backup Network Coupling	Indicates whether or not the “Backup Network Coupling” feature is enabled (Redundant links connecting two P-Ring networks)
<b>External Configuration DIP Switches</b>	
S2	When enabled, designates this switch as the Ring Master
S1	Activate Backup Coupling between 2 ring networks
<b>Environmental Specifications</b>	
MTBF	3 Fiber ports = 105,797 Hours <i>Calculation model based on MIL-HDBK-217-FN2 @ 30°C</i>
Operating Temperature Ranges	<ul style="list-style-type: none"> <li>Standard temperature models (Std): -10°C to 60°C (14°F to 140°F).</li> <li>XT Industrial extended temperature models (Ind) : -40°C to 75°C (-40°F to 167°F)</li> </ul>
Storage Temperature Range	Minimum range of -25°C to 70°C (-13°F to 158°F). -40°C to 85°C (-40°F to 185°F) for industrial extended temperature models
Operating Humidity Range	5% to 90% non-condensing
Storage Humidity Range	5% to 95% non-condensing
Maximum Heat Output	3 Fiber ports = 53.7 Btu/hr
Operating Altitude	Up to 3,048 meters (10,000 feet)
Chassis	Metal with an IP20 ingress protection rating
Din Rail Mountable	DIN Rail attachment included. Mounts to standard 35 mm DIN rail in accordance with DIN EN 60175.  Removable to accommodate optional Panel/Wall mount kit

<b>Product Weight and Dimensions</b>	
<b>Weight</b>	0.64kg (1.41lbs)
<b>Dimensions (W x H x D)</b>	13 x 12.3 x 7.5 cm (5.12 x 4.84 x 2.95 in)
<b>Packaging</b>	
<b>Shipping Weight</b>	0.94kg (2.07lbs)
<b>Shipping Dimensions</b>	20 x 19 x 18 cm (7.87 x 7.48 x 7.09 in)
<b>Standards and Certifications</b>	
<b>Safety</b>	<ul style="list-style-type: none"> <li>• UL/EN/IEC 62368-1</li> <li>• CAN/CSA C22.2 No. 62368-1</li> <li>• UL 60950-1</li> <li>• IEC 60950-1(ed 2); am1, am2</li> <li>• EN 60950-1:2006+A11:2009+A1:2010+A12:2011+A2:2013</li> <li>• UL 61010-1 and UL 61010-2-201 (Standard for Safety for Programmable Controllers) Formerly known as UL508</li> <li>• UL/IEC 61010-1</li> <li>• UL/IEC 61010-2</li> <li>• CE Mark</li> </ul>
<b>Emissions</b>	<ul style="list-style-type: none"> <li>• FCC 47 Part 15 Class A</li> <li>• CISPR 32:2015/EN 55032:2015 (Class A)</li> </ul>
<b>EMC and Immunity</b>	<ul style="list-style-type: none"> <li>• CISPR 24:2010/EN 55024:2010</li> <li>• IEC/EN 61000-4-2 (ESD) : Contact discharge +/- 4kv, Air discharge +/- 8kv</li> <li>• IEC/EN 61000-4-3 (RS) : 80mhz to 1Ghz ; 20v/m, 1.5hkhz to 2.0ghz ; 10 v/m, 2.0ghz to 2.7 ghz ; 5 v/m</li> <li>• IEC/EN 61000-4-4 (EFT) : DC power line +/- 2kv, data line +/- 1kv</li> <li>• IEC/EN 61000-4-5 (Surge) : DC power line, Line/Line +/- 1kv, Line/Earth +/- 2kv, data line /earth +/- 2kv</li> <li>• IEC/EN 61000-4-6 (CS) :150mhz-80mhz 10vrms</li> <li>• IEC/EN 61000-4-8 (Magnetic Field) :30 A/M</li> <li>• IEC/EN 61000-6-2 (General Immunity in Industrial Environments)</li> </ul>

Hazardous Locations (Hazloc)	<ul style="list-style-type: none"> <li>• ANSI/ISA 12.12.01, Class 1 Division 2 Groups A-D (formerly known as UL 1604)</li> <li>• ATEX Class 1 Zone 2</li> <li>• EN 60079-0:2012+A11:2013 and EN 60079-15:2010</li> </ul>
Environmental	<b>Reach, RoHS and WEEE Compliant</b>
Other	<ul style="list-style-type: none"> <li>• ECCN: 5A991</li> <li>• HTSUS Number: 8517.62.0020</li> <li>• 5 year Warranty</li> </ul>
Contents Shipped	<ul style="list-style-type: none"> <li>• Industrial Ethernet Switch with DIN Rail attachment</li> <li>• Terminal block</li> <li>• Installation guide</li> </ul>

## Application Diagrams

### IDS-409F Industrial Managed DIN Rail Switch

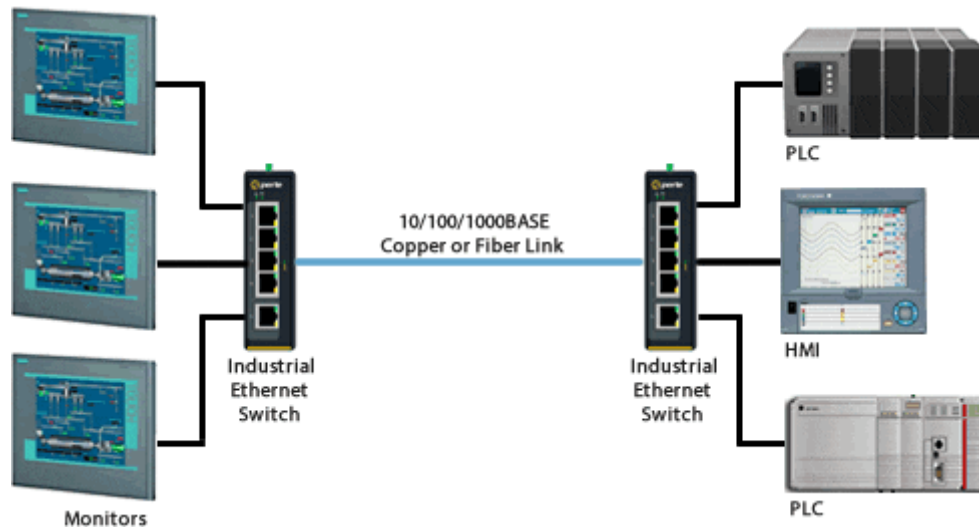

### Single Mode/Single Strand (WDM) Fiber

#### Connecting devices over a single fiber strand (also referred to as “Bi-Directional” BiDi or Simplex)

To reduce costs, or where there are limits on available fiber, Wavelength-Division Multiplexing (WDM) technology may be utilized. WDM uses separate transmit and receive frequencies to communicate on a single fiber strand. WDM technology relies on the fact that optical fibers can carry many wavelengths of light simultaneously without interaction between each wavelength. Thus, a single fiber can carry many separate wavelength signals or channels simultaneously. WDM systems are divided into different wavelength patterns, conventional/coarse (CWDM) and dense (DWDM).

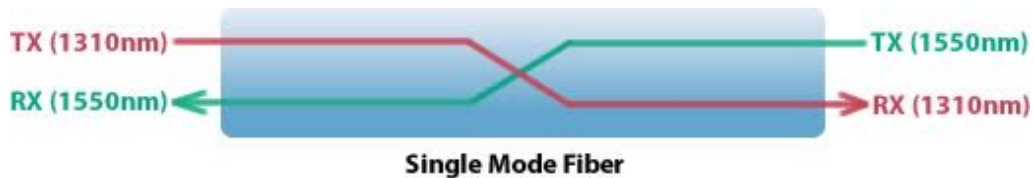

When Single Strand fiber is used, you will need an “Up” side and a “Down” side when interconnecting fiber devices.

Perle offers a wide variety of Single Fiber (“Up/Down”) **Ethernet Switches** and **Media Converters** for use with single strand of fiber.

File exists here

## Part Number: 07013600

**IDS-409F3-T2MD2-SD40 - Industrial Managed Ethernet Switch** - 9 ports: 6 x 10/100/1000Base-T RJ-45 ports and 2 x 100Base-FX, 1310nm multimode port with duplex ST connector [up to 5km/3.1 mi] and 1 x 100Base-LX, 1310nm single mode port with duplex SC connector [40 km/ 24.9 miles ]. -10 to 60C operating temperature



### Related Accessories

#### Cable Accessories

Please click here to see what adapters you may need



DBA0020C - RJ-45F to  
DB-9F crossover  
(DTE) adapter  
#1100300-10 for Perle  
serial console ports

**04007040**

## Accessories



Panel Mount Kit PM3 -  
Brackets for wall or  
panel mounting 30 to  
45mm wide Perle IDS  
Industrial Switches and

**07010290**



Rack Mount Kit RM4U  
- 4U Rack mount for  
mounting DIN Rail  
products to a 19 inch  
rack.

**07010300**

## Power Supplies



UNO-  
PS/1AC/24DC/60W  
DIN-Rail Power  
Supply: 24 VDC, 60  
Watt with universal 85

**29029928**



UNO-  
PS/1AC/24DC/150W  
Power Supply - DIN-  
Rail 24 VDC , 150 Watt  
power supply with

**29043768**