

Product Specification

Quadwire® 40 Gb/s Parallel Active Optical Cable FCBx410QD3Cyy

PRODUCT FEATURES

- Four-channel full-duplex active optical cable
- Multirate capability: 1.06Gb/s to 10.5Gb/s per channel
- Complies with QSFP MSA high-density form factor
- Round, plenum-rated (OFNP) and riser-rated (OFNR), low smoke zero halogen (LSZH) cables
- Reliable VCSEL array technology using multimode fiber
- Hot Pluggable
- Low power dissipation: <1.3W per cable end
- Commercial operating case temperature range: 0°C to 70°C
- RoHS-6 Compliant



APPLICATIONS

- InfiniBand QDR
- 40G Ethernet
- 4G/8G/10G Fibre Channel
- HPC Interconnections
- SATA/SAS3
- PCIe3

PRODUCT SELECTION (Standard Lengths*)

FCBx410QD3Cyy	
x:	N = Plenum-rated (OFNP) cable jacket R = Riser-rated (OFNR) low smoke zero halogen (LSZH) cable jacket
yy*:	03 = 3m length 05 = 5m length 10 = 10m length 15 = 15m length 20 = 20m length 30 = 30m length 50 = 50m length X0 = 100m length
*Please contact Finisar for availability of additional cable lengths.	

I. Pin Descriptions

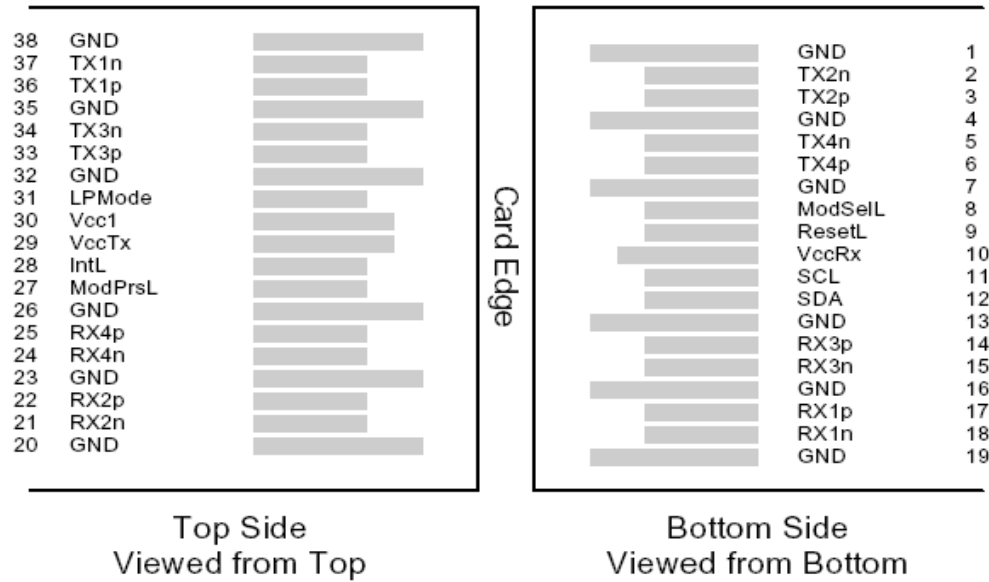

Figure 1 – QSFP MSA-compliant 38-pin connector

Pin	Symbol	Name/Description	Notes
1	GND	Ground	1
2	Tx2n	Transmitter Inverted Data Input	
3	Tx2p	Transmitter Non-Inverted Data Input	
4	GND	Ground	1
5	Tx4n	Transmitter Inverted Data Input	
6	Tx4p	Transmitter Non-Inverted Data Input	
7	GND	Ground	1
8	ModSelL	Module Select	
9	ResetL	Module Reset	
10	Vcc Rx	+3.3 V Power supply receiver	
11	SCL	2-wire serial interface clock	
12	SDA	2-wire serial interface data	
13	GND	Ground	1
14	Rx3p	Receiver Non-Inverted Data Output	
15	Rx3n	Receiver Inverted Data Output	
16	GND	Ground	1
17	Rx1p	Receiver Non-Inverted Data Output	
18	Rx1n	Receiver Inverted Data Output	
19	GND	Ground	1
20	GND	Ground	1
21	Rx2n	Receiver Inverted Data Output	
22	Rx2p	Receiver Non-Inverted Data Output	
23	GND	Ground	1
24	Rx4n	Receiver Inverted Data Output	
25	Rx4p	Receiver Non-Inverted Data Output	

26	GND	Ground	1
27	ModPrsL	Module Present	
28	IntL	Interrupt	
29	Vcc Tx	+3.3 V Power supply transmitter	
30	Vcc1	+3.3 V Power Supply	
31	LPMoDe	Low Power Mode	
32	GND	Ground	1
33	Tx3p	Transmitter Non-Inverted Data Input	
34	Tx3n	Transmitter Inverted Data Input	
35	GND	Ground	1
36	Tx1p	Transmitter Non-Inverted Data Input	
37	Tx1n	Transmitter Inverted Data Input	
38	GND	Ground	1

Notes

1. Circuit ground is internally isolated from chassis ground.

II. General Product Characteristics

Parameter	Value	Unit	Notes
Module Form Factor	QSFP		
Number of Lanes	4 Tx and 4 Rx		
Maximum Aggregate Data Rate	42.0	Gb/s	
Maximum Data Rate per Lane	10.5	Gb/s	
Standard Cable Lengths	3, 5, 10, 15, 20, 30, 50, 100	meters	Other lengths may be available upon request (<100)
Protocols Supported	Typical applications include InfiniBand, Fibre Channel, 40G Ethernet, SATA/SAS3		
Electrical Interface and Pin-out	38-pin edge connector		Pin-out as defined by the QSFP MSA
Standard Optical Cable Type	Multimode fiber cable assembly		
Maximum Power Consumption per End	1.3	Watts	Varies with output voltage swing and pre-emphasis settings (see Figure 5)
Management Interface	Serial, I2C-based, 400 kHz maximum frequency		As defined by the QSFP MSA

Data Rate Specifications	Symbol	Min	Typ	Max	Units	Ref.
Bit Rate per Lane	BR	1000		10500	Mb/sec	1
Bit Error Ratio	BER			10 ⁻¹²		2

Notes:

1. 1/10 Gigabit Ethernet and 1/2/4/8/10G Fibre Channel compatible.
2. Tested with a PRBS 2³¹-1 pattern at 10.5Gb/s, PRBS 2²³-1 pattern at 2.5Gb/s, and PRBS 2⁷-1 pattern at 1Gb/s.

III. Absolute Maximum Ratings

Parameter	Symbol	Min	Typ	Max	Unit	Ref.
Maximum Supply Voltage	Vcc1, VccTx, VccRx	-0.5		3.6	V	
Storage Temperature	T _s	-40		85	°C	1
Case Operating Temperature	T _{OP}	0		70	°C	
Relative Humidity	RH	0		85	%	2

Notes:

1. Assumes no mechanical load force on the unit. Ensuring no mechanical load force requires a cable bend radius of >105 mm within 100 mm of either cable end module and >60 mm on the rest of the cable.
2. Non-condensing.

IV. Electrical Characteristics (T_{OP} = 0 to 70°C, V_{CC} = 3.3 ± 5% Volts)

Parameter	Symbol	Min	Typ	Max	Unit	Ref.
Supply Voltage	Vcc1, VccTx, VccRx	3.15		3.45	V	
Supply Current	I _{cc}			350	mA	
Link Turn-On Time						
Transmit Turn-On Time				2000	ms	1
Transmitter (per Lane)						
Differential data input swing	V _{in,pp}	180		1200	mV _{pp}	2
Differential input threshold			50		mV	
Receiver (per Lane)						
Differential data output swing	V _{out,pp}	0		800	mV _{pp}	3,4
Power Supply Ripple Tolerance	PSR	50			mV _{pp}	

Notes:

1. From power-on and end of any fault conditions.
2. AC coupled internally. See Figure 2 for input eye mask requirements. Self-biasing 100Ω differential input.
3. AC coupled with 100Ω differential output impedance. See Figure 3 for output eye mask.
4. Settable in 4 discrete steps. See Figure 5 for V_o settings

V. High-Speed Electrical Characteristics per Lane

($T_{OP} = 0$ to 70°C , $V_{CC} = 3.3 \pm 5\%$ Volts)

Parameter –Inputs	Symbol	Conditions	Min	Typ	Max	Units	Ref.
Reference Differential Input Impedance	Z_d			100		Ω	
Termination Mismatch	ΔZ_M				5	%	1
Input AC Common Mode Voltage					25	mV (RMS)	
Differential Input Return Loss	SDD11	0.01-4.1 GHz				dB	2
		4.1 – 11.1 GHz				dB	3
Differential to Common Mode Loss	SCD11	0.01-11.1 GHz			-10	dB	
Jitter Tolerance (Total)	TJ				0.40	UI	
Jitter Tolerance (Deterministic)	DJ				0.15	UI	

Notes:

1. See SFF-8431 Rev 3.2 (SFP+) section D.15 Termination Mismatch for definition & test recommendations
2. Reflection coefficient given by equation $SDD11(\text{dB}) < -12 + 2 * \text{SQRT}(f)$, with f in GHz. See Figure 4.
3. Reflection coefficient given by equation $SDD11(\text{dB}) < -6.3 + 13 \text{Log}_{10}(f/5.5)$, with f in GHz. See Figure 4.

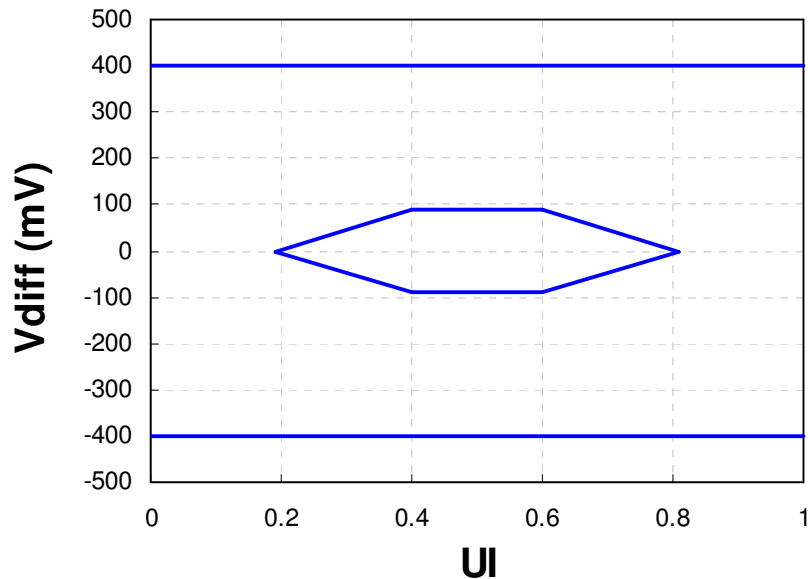

Figure 2 – Transmitter Input Differential Signal Mask

Parameter –Outputs	Symbol	Conditions	Min	Typ	Max	Units	Ref.
Reference Differential Output Impedance	Z_d			100		Ω	
Termination Mismatch	ΔZ_M				5	%	
Output AC Common Mode Voltage					15	mV _{RMS}	
Output Rise and Fall time (20% to 80%)	t_{RH}, t_{FH}		24			ps	
Differential Output Return Loss	SDD22	0.01-4.1 GHz				dB	1
		4.1 – 11.1 GHz				dB	2
Common Mode Output Return Loss	SCC22	0.01-2.5 GHz				dB	3
		2.5-11.1 GHz			-3	dB	

Notes:

1. Reflection coefficient given by equation $SDD22(dB) < -12 + 2 * \sqrt{f}$, with f in GHz. See Figure 4.
2. Reflection coefficient given by equation $SDD22(dB) < -6.3 + 13 \log_{10}(f/5.5)$, with f in GHz. See Figure 4.
3. Reflection coefficient given by equation $SCC22(dB) < -7 + 1.6 * f$, with f in GHz.

Receiver Output Jitter Specification	Symbol	Min	Typ	Max	Units	Ref.
Deterministic Jitter	DJ _{OUT}			0.38	UI	1
Total Jitter	TJ _{OUT}			0.64	UI	1

Notes:

1. When transmitter input jitter specs are met.

Other Informational Specifications (not tested)	Symbol	Min	Typ	Max	Units	Ref.
Max Bit Rate NRZ	B			10.5	Gb/s	
Low Frequency 3dB Cutoff	f_c	175			kHz	
Ch / Ch crosstalk				-26	dB	
Output Pre-emphasis				5	dB	3
Pre-Emphasis pulse width		60		90	ps	
Channel Skew				24	ns	1
Channel Latency		400	495	600	ns	1
Digital clock to data delay				25	ns	
Digital output rise/fall times				5	ns	
Digital input / output Cap				1	pF	
Digital input logic High		2			V	
Digital input logic Low				1	V	
ESD Signal pads				500	V	2
ESD (other pads)				2	kV	2

Notes:

1. For worst-case 100m length.
2. Human Body Model (HBM).
3. According to SFF-8636, Output Pre-emphasis is defined at a nominal output amplitude setting.

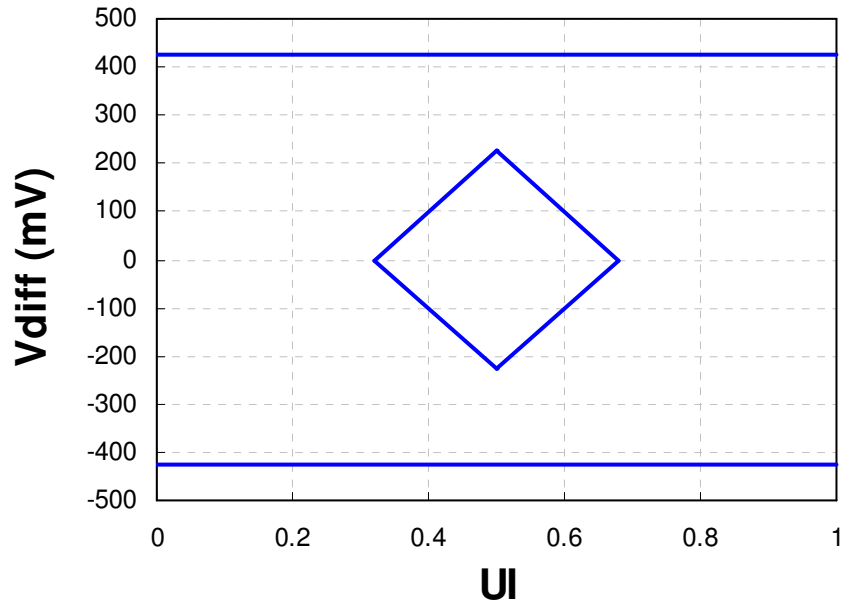

Figure 3 – Receiver Output Differential Signal Mask

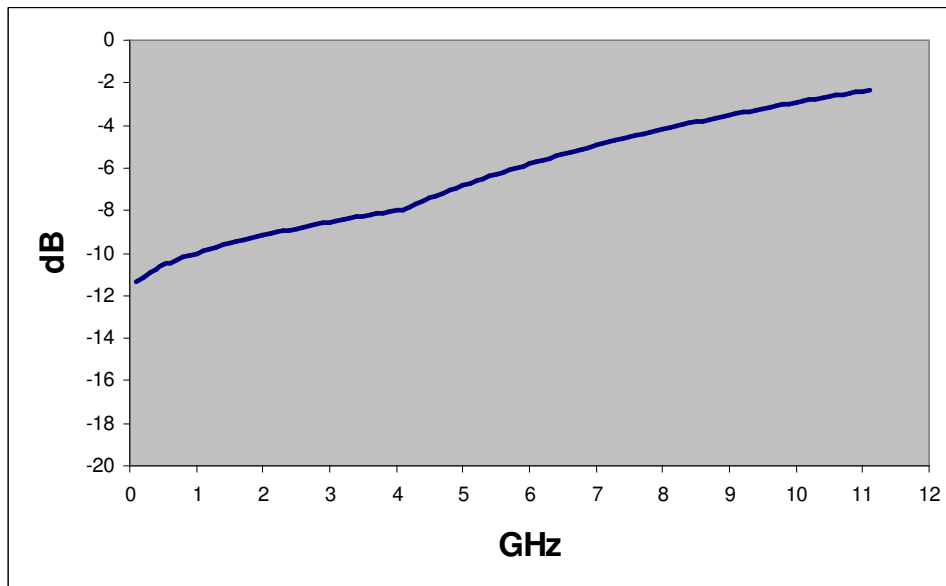

Figure 4 – Maximum Transmitter Input and Receiver Output Differential Return Loss

VI. Memory Map and Control Registers

Compatible with SFF-8436.² Please see Finisar Application Note AN-2075: Quadwire[®] EEPROM Mapping³ for details.

VII. Environmental Specifications

Finisar Quadwire[®] active optical cables have an operating temperature range from 0°C to +70°C case temperature.

Environmental Specifications	Symbol	Min	Typ	Max	Units	Ref.
Case Operating Temperature	T _{op}	0		70	°C	
Storage Temperature	T _{sto}	-40		85	°C	1

1. Assumes no mechanical load force on the unit. Ensuring no mechanical load force requires a cable bend radius of >105 mm within 100 mm of either cable end module and >60 mm on the rest of the cable.

VIII. Regulatory Compliance

Finisar Quadwire[®] active optical cables are RoHS-6 Compliant. Copies of certificates are available at Finisar Corporation upon request.

Quadwire[®] active optical cables are Class 1 laser eye safety compliant per IEC 60825-1.

The round cable jacket is available in both plenum-rated (OFNP) and riser-rated (OFNR) low smoke zero-halogen (LSZH).

IX. Mechanical Specifications

The Quadwire[®] mechanical specifications are based on QSFP transceiver module specifications, substituting the MPO connectors with a cable connecting both ends.

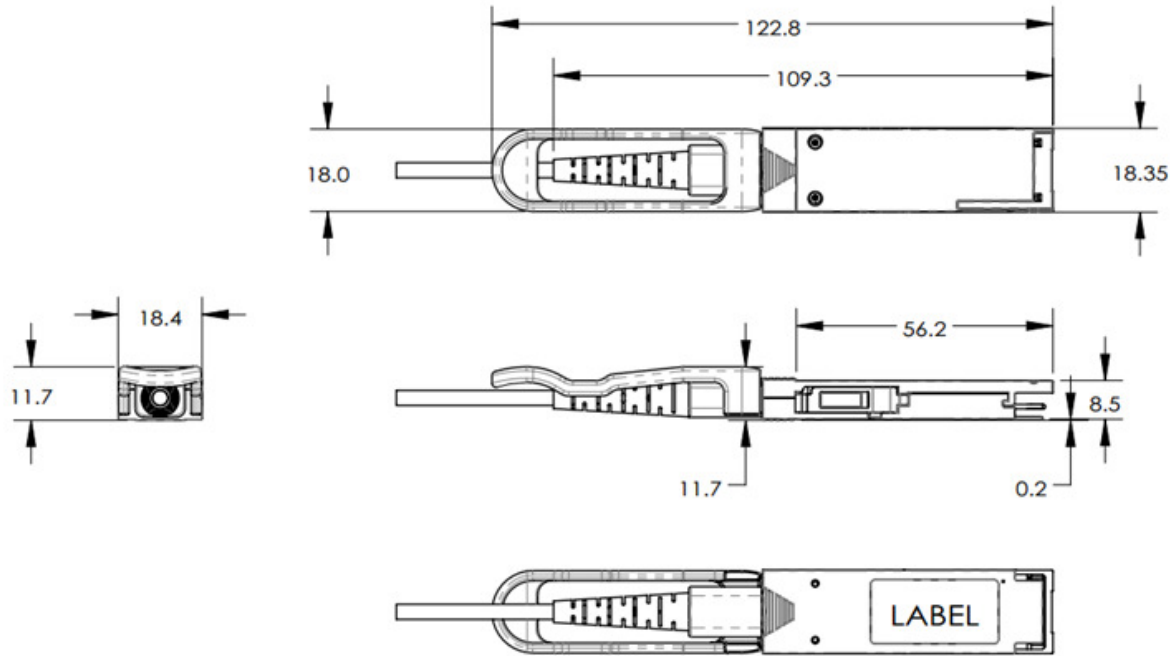

Figure 5 – Quadwire[®] mechanical drawing

Cable Mechanical Specifications	Min	Typical	Max	Units
Minimum bend radius	60			mm
Minimum bend radius within 100 mm of the Quadwire [®] module end	105			mm
Diameter	3.0	3.3	3.6	mm

Insertion, Extraction and Retention Forces	Min	Max	Units	Notes
Cable Proof (Tensile) Test (0°)		44.0	Newtons	
Cable Proof (Tensile) Test (90°)		33.0	Newtons	
Impact Test		8	Cycles	1.5m drop
Flex Test		8.9	Newtons	
Twist Test		13.0	Newtons	
Module retention	90	N/A	Newtons	No damage below 90N
Host Connector Retention	180	N/A	Newtons	No damage below 180N

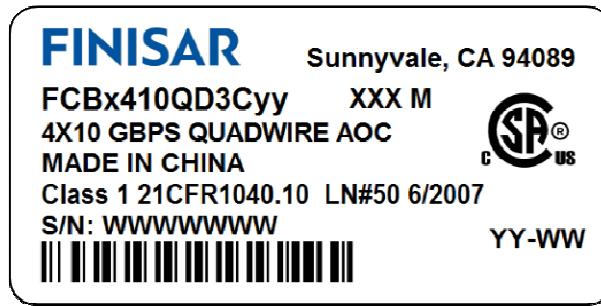

Figure 6 – Quadwire[®] production-level product label

X. References

1. INF-8438i – Specification for QSFP (Quad Small Formfactor Pluggable) Transceiver, Rev 1.0, November 2006
2. SFF-8636 – Specification for QSFP+ Copper and Optical Transceiver, Rev 2.7, January 2016
3. Application Note AN-2075: Quadwire[®] EEPROM Mapping, Rev E

XI. For More Information

Finisar Corporation
1389 Moffett Park Drive
Sunnyvale, CA 94089-1133
Tel. 1-408-548-1000
Fax 1-408-541-6138
sales@finisar.com
www.finisar.com

Mouser Electronics

Authorized Distributor

Click to View Pricing, Inventory, Delivery & Lifecycle Information:

[II-VI:](#)

[FCBN410QD3C40](#) [FCBN410QD3C30](#) [FCBN410QD3C20](#) [FCBN410QD3C03](#) [FCBN410QD3C05](#) [FCBN410QD3C10](#)
[FCBN410QD3C15](#) [FCBN410QD3C01](#) [FCBN410QD3C50](#)