



**TECHDOCS**

# **ION 1200-S Hardware Reference**

---

## Contact Information

Corporate Headquarters:

Palo Alto Networks

3000 Tannery Way

Santa Clara, CA 95054

[www.paloaltonetworks.com/company/contact-support](http://www.paloaltonetworks.com/company/contact-support)

## About the Documentation

- For the most recent version of this guide or for access to related documentation, visit the Technical Documentation portal [docs.paloaltonetworks.com](http://docs.paloaltonetworks.com).
- To search for a specific topic, go to our search page [docs.paloaltonetworks.com/search.html](http://docs.paloaltonetworks.com/search.html).
- Have feedback or questions for us? Leave a comment on any page in the portal, or write to us at [documentation@paloaltonetworks.com](mailto:documentation@paloaltonetworks.com).

## Copyright

Palo Alto Networks, Inc.

[www.paloaltonetworks.com](http://www.paloaltonetworks.com)

© 2023-2023 Palo Alto Networks, Inc. Palo Alto Networks is a registered trademark of Palo Alto Networks. A list of our trademarks can be found at [www.paloaltonetworks.com/company/trademarks.html](http://www.paloaltonetworks.com/company/trademarks.html). All other marks mentioned herein may be trademarks of their respective companies.

## Last Revised

November 29, 2023

---

# Table of Contents

<b>Before You Begin.....</b>	<b>5</b>
Tamper Proof Statement.....	6
Third-Party Component Support.....	7
Product Safety Warnings.....	8
<b>ION 1200-S Overview.....</b>	<b>13</b>
Overview ION 1200-S.....	14
ION 1200-S Hardware Specifications.....	16
ION 1200-S Front Panel.....	20
ION 1200-S-C-NA/ROW Front Panel.....	22
ION 1200-S-C5G-WW Front Panel.....	24
ION 1200-S Back Panel.....	26
ION 1200-S-C-NA/ROW Back Panel.....	27
ION 1200-S-C-5G Back Panel.....	28
ION 1200-S Compliance Statement.....	29
Installation Kit Components.....	34
ION 1200-S LEDs.....	35
Power on the ION 1200.....	37
Restart the ION 1200.....	37
Shut Down the ION 1200.....	37
<b>Install ION 1200-S.....</b>	<b>39</b>
Insert SIM Cards in the ION 1200-S.....	40
Install Antennas in the ION 1200-S.....	41
Install the ION 1200-S on a Flat Surface.....	43
Install the ION 1200-S on a wall.....	44
ION 1200-S Wall Mount Template.....	47
Install the ION 1200-S on a Rack.....	48
<b>Troubleshoot ION 1200-S Series.....</b>	<b>53</b>
Troubleshoot Common Issues with the ION 1200-S Series.....	54



# Before You Begin

- [Tamper Proof Statement](#)
- [Third-Party Component Support](#)
- [Product Safety Warnings](#)

## Tamper Proof Statement

To ensure that products purchased from Palo Alto Networks were not tampered with during shipping, verify the following upon receipt of each product:

- The tracking number provided to you electronically when ordering the product matches the tracking number that is physically labeled on the box or crate.
- The integrity of the tamper-proof tape used to seal the box or crate is not compromised.
- The integrity of the warranty label on the firewall or appliance is not compromised.

## Third-Party Component Support

Before you consider installing third-party hardware, read the [Palo Alto Networks Third-Party Component Support](#) statement.

## Product Safety Warnings

To avoid personal injury or death for yourself and others and to avoid damage to your Palo Alto Networks hardware, be sure you understand and prepare for the following warnings before you install or service the hardware. You will also see warning messages throughout the hardware reference where potential hazards exist.



All Palo Alto Networks products with laser-based optical interfaces comply with 21 CFR 1040.10 and 1040.11.

The following safety warnings apply to all Palo Alto Networks firewalls and appliances, unless a specific hardware model is specified.

- When installing or servicing a Palo Alto Networks firewall or appliance hardware component that has exposed circuits, ensure that you wear an electrostatic discharge (ESD) strap. Before handling the component, make sure the metal contact on the wrist strap is touching your skin and that the other end of the strap is connected to earth ground.

**French Translation:** Lorsque vous installez ou que vous intervenez sur un composant matériel de pare-feu ou de dispositif Palo Alto Networks qui présente des circuits exposés, veillez à porter un bracelet antistatique. Avant de manipuler le composant, vérifiez que le contact métallique du bracelet antistatique est en contact avec votre peau et que l'autre extrémité du bracelet est raccordée à la terre.

- Use grounded and shielded Ethernet cables to ensure agency compliance with electromagnetic compliance (EMC) regulations.

**French Translation:** Des câbles Ethernet blindés reliés à la terre doivent être utilisés pour garantir la conformité de l'organisme aux émissions électromagnétiques (CEM).

- WAN and LAN ethernet ports are suitable for interconnection to other local device ethernet ports. These ports are not designed for direct connection to Public Switched Telephone Network (PSTN) ports or interfaces. In addition, copper-based WAN ports, LAN ports, and copper-based modular transceivers are not rated to connect to telecommunications Outside Plant (OSP) cabling.
- I/O ports are intended for intra-building connections only and not intended for OSP (Outside Plant) connections or any network connections subject to external voltage surge events.

	<p>(All Palo Alto Networks appliances with two or more power supplies)</p> <p>Caution: Shock hazard</p> <p>Disconnect all power cords (AC or DC) from the power inputs to fully de-energize the hardware.</p> <p><b>French Translation:</b> (Tous les appareils Palo Alto Networks avec au moins deux sources d'alimentation) Débranchez tous les cordons d'alimentation (c.a. ou c.c.) des entrées d'alimentation et mettez le matériel hors tension.</p>
--	--

- **Radio Frequency (RF) Radiation Exposure Warning:** Hazardous Radiation Exposure Warning —Adjustments or procedures other than those specified may result in hazardous RF radiation exposure. A minimum distance of 20cm (7.87in) must be maintained between the operating radio antennas and personnel.
- **Antenna Installation Warning:** To avoid hazardous RF radiation exposure, ensure the device is switched off when installing or changing antennas.
- **Cellular Devices:** The USB 2.0 port on the cellular device is used for maintenance only.
- **International Statements and Information Pertaining to Radio Products**
  - **Information on compliance to RF exposure guidelines:** The Palo Alto Networks cellular-enabled devices are designed to comply with the following national and international standards on human RF exposure. To ensure compliance with these RF exposure standards, the device is advised to be operated only with Palo Alto Networks approved antennas and accessories.
    - US 47 Code of Federal Regulations Part 2
    - American National Standards Institute (ANSI) / Institute of Electrical and Electronic Engineers / IEEE C 95.1 (99)
    - International Commission on Non-Ionizing Radiation Protection (ICNIRP) 98
    - Ministry of Health (Canada) Safety Code 6, Limits on Human Exposure to Radio Frequency Fields in the range from 3KHz to 300GHz
    - Australia Radiation Protection Standard
  - **International Guidelines for Exposure to Radio Waves:** The cellular enabled devices include a radio transmitter and receiver. It is designed not to exceed the limits for exposure to RF radiation specified in ICNIRP guidelines that were devised to include a substantial safety margin to ensure the safety of all persons, regardless of age and health.

The World Health Organization has stated that current scientific information does not indicate a need for special precautions for wireless devices. They also recommend that further exposure reductions are possible by orienting antennas away from personnel or by increasing the separation distance.

- **Additional Information on RF Exposure:**
  - FCC Bulletin 56: Questions and Answers about Biological Effects and Potential Hazards of Radio Frequency Electromagnetic Fields
  - FCC Bulletin 65: Evaluating Compliance with the FCC guidelines for Human Exposure to Radio Frequency Electromagnetic Fields
  - FCC Bulletin 65C (01-01): Evaluating Compliance with the FCC guidelines for Human Exposure to Radio Frequency Electromagnetic Fields: Additional Information for Evaluating Compliance for Mobile and Portable Devices with FCC limits for Human Exposure to Radio Frequency Emission
  - World Health Organization Internal Commission on Non-Ionizing Radiation Protection at this URL: [www.who.int/emf](http://www.who.int/emf)
  - United Kingdom, National Radiological Protection Board at this URL: [www.nrpb.org.uk](http://www.nrpb.org.uk)
  - Cellular Telecommunications Association at this URL: [www.ctia.org/](http://www.ctia.org/)
  - The Mobile and Wireless Forum (MWF) at this URL: [www.emfhealth.info/index.cfm](http://www.emfhealth.info/index.cfm)

- **National Statements and Information Pertaining to Radio Products**

- **US**

- **RF Exposure Warning:** This equipment was evaluated to FCC radio frequency (RF) exposure limits set forth for an uncontrolled environment. To comply with FCC exposure limits, antennas for this product must be located at a distance of a minimum of 20cm (7.87in) or more from all persons.
- **Product Modification Warning:** The radio contained in this product operates with other devices in this frequency band and with other services operating within the radio spectrum. Any changes or modifications to the product without approval from Palo Alto Networks could void the user's authority to operate the device. Such modifications include the use of non-approved antennas, accessories, or amplifiers. The radio has been evaluated under FCC Bulletin OET 65C and found compliant to the requirements as set forth in CFR 47 Sections 2.1091.
- **Cellular Products:** This device operates under the authority of a licensed radio service under 47 Code of Federal Regulations Parts 22, 24, and 27.
- **FCC Co-location:** This product must not be co-located or operate in conjunction with another radio.
- **FCC Guidelines for Exposure to Radio Waves:** The cellular enabled devices include a radio transmitter and receiver. It is designed not to exceed the limits for exposure to RF radiation specified in FCC Part 1.1310. The FCC guidelines are based on IEEE ANSI C 95.1 (92) and include a substantial safety margin to ensure the safety of all persons, regardless of age and health. The device has been tested and found compliant with the applicable regulations as part of the radio certification process. The US Food and Drug Administration (FDA) has stated that current scientific information does not indicate a need for special precautions for wireless devices. The FCC recommends that further exposure reductions are possible [1] by orienting antennas away from personnel, [2] by increasing the separation distance.

- **Canada**

- **Industry Canada Radio Interference Statement:** This device contains transmitter(s)/ receiver(s) that comply with Innovation, Science and Economic Development (ISED) Canada's license-exempt RSS(s). Operation is subject to the following two conditions:

This device may not cause interference.

This device must accept any interference, including interference that may cause undesired operation of the device.

**French Translation:** L'émetteur/récepteur exempt de licence contenu dans le présent appareil est conforme aux CNR d'Innovation, Sciences et Développement économique Canada applicables aux appareils radio exempts de licence. L'exploitation est autorisée aux deux conditions suivantes: L'appareil ne doit pas produire de brouillage. L'appareil doit

accepter tout brouillage radioélectrique subi, même si le brouillage est susceptible d'en compromettre le fonctionnement.

- **RF Exposure Warning:** This equipment complies with ISED RF exposure limits set forth for an uncontrolled environment. This equipment must be installed and operated with a minimum distance of 20cm (7.87in) between personnel and the radio antennas.
- **ISED Co-location:** This product must not be co-located or operate in conjunction with another radio.
- **Industry Canada Guidelines for Exposure to Radio Waves:** The cellular enabled devices include a radio transmitter and receiver. It is designed not to exceed the limits for exposure to RF radiation as referenced in Health Canada Safety Code 6. Those guidelines include a substantial safety margin to ensure the safety of all persons, regardless of age and health.

Health Canada states that current scientific information does not indicate a need for special precautions for wireless devices. Health Canada recommends that further exposure reductions are possible [1] by orienting antennas away from personnel or [2] by increasing the separation distance.

The systems are designed to be operated to avoid contact with the antennas by the user. It is recommended to set the system in a location where the antennas can remain at least a minimum distance as specified from the user in accordance with the regulatory guidelines which are designed to reduce the exposure to the user.

- **EU**

This equipment is intended to be used in all EU and EFTA countries. Outdoor use may be restricted to certain frequencies and/or may require a license for operation. The use of wireless devices in hazardous locations is limited to the constraints posed by the safety directors of such environments. The use of a portable device may be restricted in some locations.

The use of wireless devices in hospitals is restricted to the limits set forth by each hospital. The use of software or firmware not supported/provided by the manufacturer may result in the equipment being no longer compliant with the regulatory requirements.

- **Australia and New Zealand**

To ensure compliance with RF exposure standards, the system must only be operated with Palo Alto Networks approved antennas and accessories.

To ensure compliance with exposure limits to radio frequency fields, the antenna must be no closer than 20cm (7.87in) from personnel.

Radio communications devices are sometimes used for radio applications with commercial or safety of life implications. Users of such applications are encouraged to have particular regard to the suitability of operating under the Australian Radio communications Class License for their radio communications need.



# ION 1200-S Overview

Learn about the next generation SASE ION 1200-S device.

- [ION 1200-S Front Panel](#)
- [ION 1200-S-C-NA/ROW Front Panel](#)
- [ION 1200-S-C5G-WW Front Panel](#)
- [ION 1200H-S-C5G-WW Front Panel](#)
- [ION 1200-S Back Panel](#)
- [ION 1200-S-C-NA/ROW Back Panel](#)
- [ION 1200-S-C-5G Back Panel](#)
- [#unique\\_13](#)
- [ION 1200-S Compliance Statement](#)
- [ION 1200-S LEDs](#)
- [Power on the ION 1200](#)
- [Installation Kit Components](#)



- **ION 1200-S-C5G-WW**

Enterprise small branch with integrated Layer 2 switch ports and 5G for world wide (WW).

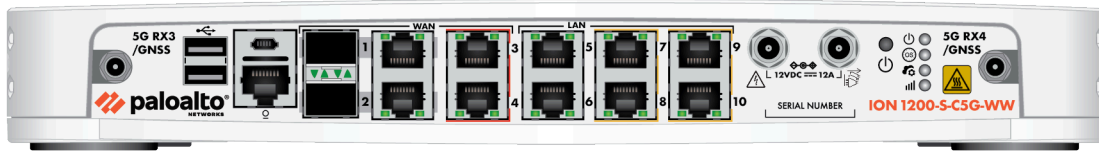



- **ION 1200H-S-C5G-WW**

The Prisma SD-WAN ION 1200H-S-C5G-WW Series Next-Generation temperature hardened ION device. This device is designed for enterprise small branch with integrated Layer 2 switch ports and 5G for world wide (WW) and have the following main features:

- a TPM module for key storage and security
- ZTP functionality
- active/passive and active/active high availability (HA)
- 5G capability for select models
- Power Over Ethernet (PoE) support

## ION 1200-S Hardware Specifications

Learn the hardware specifications of the following ION 1200-S variants series:

	ION 1200-S	ION 1200-S-C-NA	ION 1200-S-C-ROW	ION 1200-S-C5G-WW
Description	Enterprise small branch device with L2 switch ports.	Enterprise small branch device with integrated with L2 switch ports and 4G LTE for North America.   <i>Do not deploy this device outside North America.</i>	Enterprise small branch device with integrated with L2 switch ports and 4G LTE for APAC and EMEA.   <i>Do not deploy this device in North America.</i>	Enterprise small branch device with integrated with L2 switch ports and 5G for world wide.

### Ports

Console Port	1 x RJ-45
WAN/LAN ports	<b>WAN/LAN Ports</b> 2x RJ-45 10/100/1000Mbps/SFP combo ports, 2x 10/100/1000Mbps RJ-45. <b>LAN ports</b> 6x 10/100/1000Mbps RJ-45 L2 Switch Ports. By default, all ports are DHCP-enabled, ports 1 and 2 are used to connect to internet.
L2 Switch Ports	6xRJ-45 LAN, 1Gbps <ul style="list-style-type: none"> <li>• 4 x PoE (802.3af) 15.4 W maximum</li> <li>• 3 x PoE+ (802.3at) 30 W maximum</li> <li>• 1 x PoE++ (802.3bt) 60 W maximum for type 3 PSEs.</li> </ul>
L2 ports PoE	90W PoE budget, 4xPoE ports, 60W max/port
USB 3.0	2 x Type-A
Bypass Pair	2xRJ-45 (1pair)
eMMC Storage	128GB

	ION 1200-S	ION 1200-S-C-NA	ION 1200-S-C-ROW	ION 1200-S-C5G-WW
Memory	8GB			
Type or Watts	150W Power adapter *derated to 50W above 45C			
Power Input	AC 100–240 V, 50–60Hz The power adapter converts the AC power to 12VDC to provide power to the device.			
<b>Mechanical</b>				
System Cooling	Fanless			
<b>Certifications</b>				
Certifications	IEC 62368-1, cTUVus, FCC, CE B, RoHS, FIPS	IEC 62368-1, cTUVus, FCC, CE B, RoHS, FIPS	IEC 62368-1, cTUVus, FCC, CE B, RoHS, FIPS	IEC 62368-1, cTUVus, FCC, CE B, RoHS, FIPS
<b>Environmental</b>				
Operating temperature (3000 m altitude)	32–104°F (0–40°C) 1200-S-C5G-WW (PoE disabled) operates 32–140°F(0–60°C)	32–104°F (0–40°C) 1200-S-C5G-WW (PoE disabled) operates 32–140°F(0–60°C)	32–104°F (0–40°C) 1200-S-C5G-WW (PoE disabled) operates 32–140°F(0–60°C)	32–104°F (0–40°C) 1200-S-C5G-WW (PoE disabled) operates 32–140°F(0–60°C)
Storage temperature	-4°F - 158°F (-20°C - 70°C)	-4°F - 158°F (-20°C - 70°C)	-4°F - 158°F (-20°C - 70°C)	-4°F - 158°F (-20°C - 70°C)
Operating humidity (non-condensing)	10-90%	10-90%	10-90%	10-90%
Storage humidity (non-condensing)	10-90%	10-90%	10-90%	10-90%
<b>Physical</b>				
Dimensions	9" Wx 13"L x 1.73"H			

	ION 1200-S	ION 1200-S-C-NA	ION 1200-S-C-ROW	ION 1200-S-C5G-WW
Weight (lbs)	7.85	7.85	7.85	7.85
Mount options	Rack, Desktop	Rack, Desktop	Rack, Desktop	Rack, Desktop

### Cellular specifications

SIM Slot Size	Not Supported	Nano (4FF)	Nano (4FF)	Nano (4FF)
Radio	Not Supported	Main (TX/RX1) AUX (RX2) GNSS	Main (TX/RX1) AUX (RX2) GNSS	Main (TX1/ RX1) MIMO1(TX2/ RX2) MIMO2 (RX3/ GNSS L5) AUX (RX4/ GNSS L1)
Antenna Terminal	Not Supported	SMA (F)	SMA (F)	SMA (F)
GNSS/GPS	Not Supported	GPS Standalone	GPS Standalone	GPS Standalone
Supported RF bands	Not Supported	<b>LTE:</b> B2, B4, B5, B7, B12, B13, B14, B25, B26, B41, B42, B43, B48, B66, B71 <b>3G:</b> B2, B4, B5	<b>LTE:</b> B1, B3, B7, B8, B20, B28, B32, B38, B40, B41, B42, B43 <b>3G:</b> B1, B5, B8	<b>5G NR Sub-6GHz (FR1):</b> n1, n2, n3, n5, n7, n8, n12, n20, n25, n28, n38, n40, n41, n66, n71, n77, n78, n79 <b>LTE:</b> B1, B2, B3, B4, B5, B7, B8, B12, B13, B14, B17, B18, B19, B20, B21, B25, B26, B28, B29, B30, B32, B34, B38, B39, B40, B41, B42, B43, B46, B66, B71

	ION 1200-S	ION 1200-S-C-NA	ION 1200-S-C-ROW	ION 1200-S-C5G-WW
				3G: B1, B2, B4, B5, B6, B8, B9, B19
Cellular Carrier Certification	Not Supported	<ul style="list-style-type: none"> <li>• AT&amp;T</li> <li>• Verizon</li> <li>• PTCRB</li> <li>• T-Mobile</li> <li>• Telstra</li> </ul>	<ul style="list-style-type: none"> <li>• GCF</li> </ul>	<ul style="list-style-type: none"> <li>• AT&amp;T</li> <li>• PTCRB</li> <li>• T-Mobile</li> <li>• Verizon</li> <li>• GCF</li> <li>• Telstra</li> </ul>

## ION 1200-S Front Panel

The following image shows the front panel of the ION 1200-S and the table describes the front panel components.

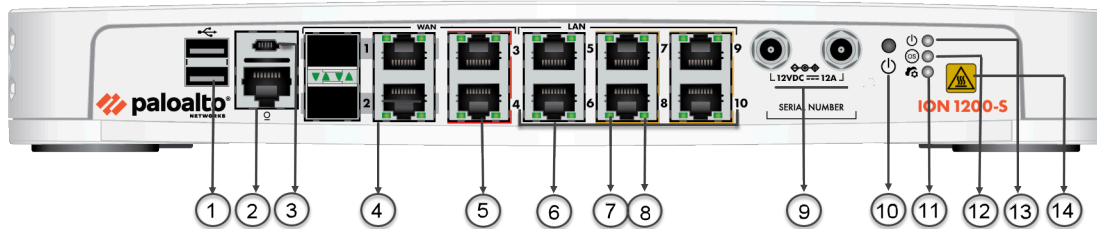

Item	Component	Description
1	USB Port	USB 3.0 (reserved for future use).
2	Console Port	RJ-45 Serial console port.
3	Micro USB	Micro USB Type B Console connector.
4	SFP/RJ-45 Combo Ports	Ports 1 and 2 are 10/100/1000Mbps SFP/RJ-45 combo ports.
5	Bypass Pair	Ports 3 and 4 are bypass pairs. Bypass is indicated with an orange bar above and below the ports.
6	Ethernet Ports	Ports 5-10 are access ports. Ports 7-10 are PoE ports indicated with a yellow bar above and below the ports.
7	Link Speed LED	On ethernet ports 1-10, the left LED indicates the link speed.
8	Activity LED	On ethernet ports 1-10, the right LED indicates the activity on the port.
9	Power	Power Input.
10	Restart button	Restart button.
11	Controller LED	Controller LED; the LED turns green on successful connection with the Prisma SD-WAN controller.
12	OS LED	Operating System status LED.

Item	Component	Description
13	Power LED	Power LED; the LED turns green when powered on.
14	Heat Label	Heat label on the device.

## ION 1200-S-C-NA/ROW Front Panel

The front panel of the ION 1200-S-C-NA and ION 1200-S-C-ROW are identical. The following image shows the front panel of the ION 1200-S-C-NA/ROW and the table describes the front panel components.

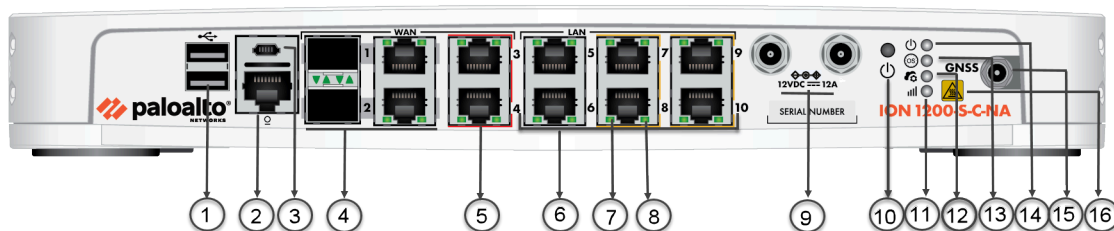

Item	Component	Description
1	USB Port	USB 3.0 (reserved for future use).
2	Console Port	RJ-45 Serial console port.
3	Micro USB	Micro USB Type B Console connector.
4	SFP/RJ-45 Combo Ports	Ports 1 and 2 are SFP/RJ-45 combo ports.
5	ByPass Pair	Ports 3 and 4 are bypass pairs. ByPass ports are indicated with an orange bar above and below the ports.
6	Ethernet Ports	Ports 1-10 are access ports. Ports 7-10 are PoE ports indicated with a yellow bar above and below the ports.
7	Link Speed LED	On ethernet ports 1-10, the left LED indicates the link speed.
8	Activity LED	On ethernet ports 1-10, the right LED indicates the activity on the port.
9	Power	Power Input.
10	Restart button	Restart button.
11	Cellular LED	Cellular LED; the LED indicates signal strength. Refer <a href="#">ION 1200-S LEDs</a> to know more.

Item	Component	Description
12	Controller LED	Controller LED; the LED turns green on successful connection with the Prisma SD-WAN controller.
13	OS LED	Operating System status LED.
14	Power LED	Power LED; the LED turns green when powered on.
15	Antenna Connector	Antenna SMA (F) Connectors. ION 1200-S-C-NA/ROW has three antenna connectors—Main (TX/RX1), Aux (RX2), GNSS.
16	Heat Label	Heat label on the device.

## ION 1200-S-C5G-WW Front Panel

The following image shows the front panel of the ION 1200-S-C5G-WW and the table describes the front panel components.

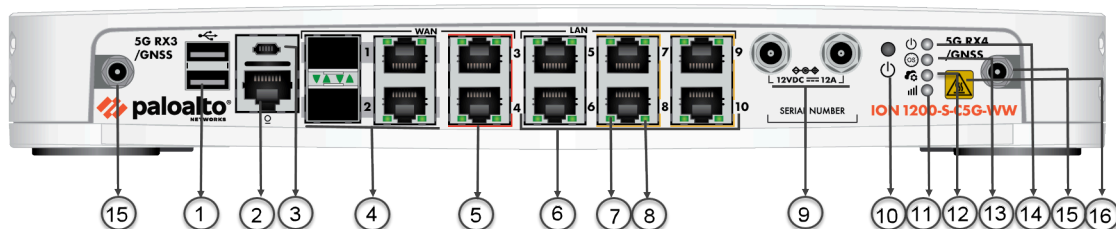

Item	Component	Description
1	USB Port	USB 3.0 (reserved for future use).
2	Console Port	RJ-45 Serial console port.
3	Micro USB	Micro USB Type B Console connector.
4	SFP/RJ-45 Combo Ports	Ports 1 and 2 are RJ-45/SFP Combo ports.
5	ByPass Pair	Ports 3 and 4 are bypass pairs. ByPass ports are indicated with an orange bar above and below the ports.
6	Ethernet Ports	Ports 1-10 are access ports. Ports 7-10 are PoE ports indicated with a yellow bar above and below the ports.
7	Link Speed LED	On ethernet ports 1-4, the left LED indicates the link speed.
8	Activity LED	On ethernet ports 1-4, the right LED indicates the activity on the port.
9	Power	Power Input.
10	Restart Button	Restart button.
11	Cellular LED	Cellular LED; the LED indicates signal strength. Refer <a href="#">ION 1200-S LEDs</a> to know more.

Item	Component	Description
12	Controller LED	Controller LED; the LED turns green on successful connection with the Prisma SD-WAN controller.
13	OS LED	Operating System status LED.
14	Power LED	Power LED; the LED turns green when powered on.
15	Antenna Connector	Antenna SMA (F) Connectors. ION 1200-C5G-WW has four antenna connectors—Main (TX1/RX1), MIMO1 (TX2/RX2), MIMO2 (RX3 GNSS L5), AUX (RX4/GNSS L1).
16	Heat Label	Heat label on the device.

## ION 1200-S Back Panel

The following image shows the back panel of the ION 1200-S and the table describes the back panel components.

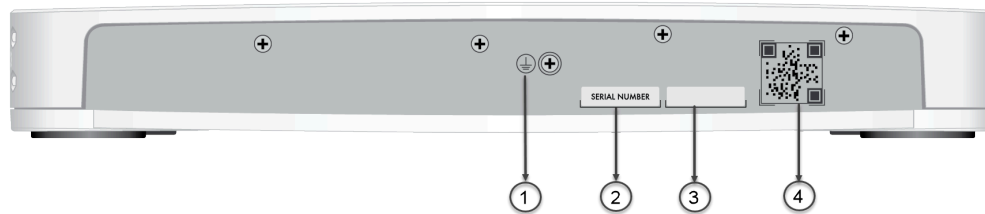

Item	Component	Description
1	Earthing	Earth ground connection. The ground connector is not required during normal operation.
2	Serial Number	Serial number of the ION device.
3	Part Number	Part number of the ION device.
4	QR Code	QR code links to the <a href="#">ION 1200 Hardware Reference</a> .

## ION 1200-S-C-NA/ROW Back Panel

The back panel of the cellular ION 1200-S-C-NA and ION 1200-S-C-ROW are similar. The following image shows the back panel of the cellular ION 1200-S-C-NA device and ION 1200-S-C-ROW and the table describes the back panel components.

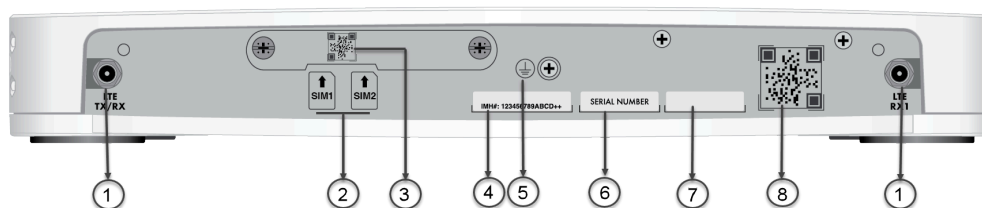

Item	Component	Description
1	Antenna Connectors	Antenna SMA (F) connectors.
2	SIM slots	2 SIM slots for cellular network connectivity.
3	SIM Cover and QR Code	SIM cover that covers the SIM slots and QR Code on the SIM cover.
4	IMEI Label	IMEI number of the device.
5	Earthing	Earth ground connection. The ground connector is not required during normal operation.
6	Serial Number	Serial number of the ION device.
7	Part Number	Part number of the ION device.
8	QR Code	QR code links to the <a href="#">SIM installation</a> section of the Hardware Reference.

## ION 1200-S-C-5G Back Panel

The following image shows the back panel of the cellular ION 1200-S-C5G-WW device and the table describes the back panel components.

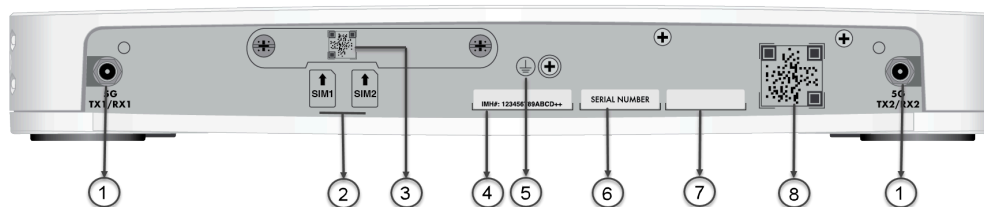

Item	Component	Description
1	Antenna Connector	Antenna SMA (F) connectors.
2	SIM slots	2 SIM slots for cellular network connectivity.
3	SIM Cover with QR Code	SIM cover that covers the SIM slots. QR code links to the <a href="#">ION 1200 Hardware Reference</a> .
4	IMEI Label	IMEI number of the device.
5	Earthing	Earth ground connection. The ground connector is not required during normal operation.
6	Serial Number	Serial number of the ION device.
7	Part Number	Part Number of the ION device.
8	QR Code	QR code links to the <a href="#">SIM installation</a> section of the Hardware Reference.

## ION 1200-S Compliance Statement

The following compliance statements apply to this ION device:

- **VCCI**—This section provides the compliance statement for the Voluntary Control Council for Interference by Information Technology Equipment (VCCI), which governs radio frequency emissions in Japan.

The following information is in accordance to VCCI Class A requirements:

この装置は、クラスA情報技術装置です。この装置を家庭環境で使用すると電波妨害を引き起こすことがあります。この場合には使用者が適切な対策を講ずるよう要求されることがあります。 VCCI-A

**Translation:** This is a Class A product. In a domestic environment this product may cause radio interference, in which case the user may be required to take corrective actions.

- **UL**—Product Ambient Temperature: 0~40 degree C
-  *Risk of explosion if battery is replaced by an incorrect type. Dispose of used battery according to local regulations.*
- **CE (European Union (EU) Directives)**
  - ION 1200-S is herewith confirmed to comply with the requirements set out in the Council Directive on the Approximation of the Laws of the Member States relating to the LVD Directive 2014/35/EU, EMC Directive 2014/30/EU, WEEE Directive 2012/19/EU, and RoHS Directives 2011/65/EU and 2015/863/EU.
  - ION 1200-S-C-ROW is in conformity with the harmonized standards and fulfills the essential requirements of the Radio Equipment Directive 2014/53/EU, WEEE Directive 2012/19/EU, and RoHS Directives 2011/65/EU and 2015/863/EU. The full text of the EU declaration of conformity for the model is available at the following link:  
[ION 1200-S-C-ROW](#)
  - ION 1200-S-C5G-WW is in conformity with the harmonized standards and fulfills the essential requirements of the Radio Equipment Directive 2014/53/EU, WEEE Directive 2012/19/EU, and RoHS Directives 2011/65/EU and 2015/863/EU. The full text of the EU declaration of conformity for the model is available at the following link:  
[ION 1200-S-C5G-WW](#)
- **United Kingdom Declaration of Conformity (UKCA) Directives:**
  - ION 1200-S is in conformity with the designated standards and fulfills the requirements of the Electrical Equipment (Safety) Regulations 2016, Electromagnetic Compatibility

Regulations 2016, and The Restriction of the Use of Certain Hazardous Substances in Electrical and Electronic Equipment Regulations 2012.

- ION 1200-S-C-ROW is in conformity with the following designated standards and fulfills the requirements of the Electrical Equipment (Safety) Regulations 2016, Electromagnetic Compatibility Regulations 2016, Radio Equipment Regulations 2017, and The Restriction of the Use of Certain Hazardous Substances in Electrical and Electronic Equipment Regulations 2012. The full text of the UK declaration of conformity for the model is available at the following link:

[ION 1200-S-C-ROW](#)

- ION 1200-S-C5G-WW is in conformity with the designated standards and fulfills the requirements of the Electrical Equipment (Safety) Regulations 2016, Electromagnetic Compatibility Regulations 2016, Radio Equipment Regulations 2017, and The Restriction of the Use of Certain Hazardous Substances in Electrical and Electronic Equipment Regulations 2012. The full text of the UK declaration of conformity for the model is available at the following link:

[ION 1200-S-C5G-WW](#)

- ION 1200H-S-C5G-WW is in conformity with the harmonized standards and fulfills the essential requirements of the Radio Equipment Directive 2014/53/EU, WEEE Directive 2012/19/EU, and RoHS Directives 2011/65/EU and 2015/863/EU. The full text of the EU declaration of conformity for the model is available at the following link:

[ION 1200-H-S-C5G-WW](#)

- **Federal Communications Commission (FCC) statement for a Class A digital device or peripheral**—This equipment has been tested and found to comply with the limits for a Class A digital device, pursuant to Part 15 of the FCC Rules. These limits are designed to provide reasonable protection against harmful interference in a residential installation. This equipment generates, uses, and can radiate radio frequency energy and, if not installed and used in accordance with the instructions, may cause harmful interference to radio communications. However, there is no guarantee that interference will not occur in a particular installation. If this equipment does cause harmful interference to radio or television reception, which can be

determined by turning the equipment off and on, the user is encouraged to try to correct the interference by one or more of the following measures.

**Supplier's Declaration of Conformity**  
**47 CFR § 2.1077 Compliance Information**

**Unique Identifiers:** ION 1200-S, ION 1200-S-C-NA, ION 1200-S-C5G-WW

**Responsible Party – U.S. Contact Information**

Palo Alto Networks  
3000 Tannery Way  
Santa Clara, California 95054 USA  
408-753-4000

[www.paloaltonetworks.com](http://www.paloaltonetworks.com)

**Authorized Components**

The ION 1200-S-C-NA uses Sierra Wireless module EM7411, FCC ID N7NEM74B.

The ION 1200-S-C5G-WW uses Sierra Wireless module EM9190, FCC ID N7NEM91.

**FCC Compliance Statement**

This device complies with Part 15 of the FCC Rules. Operation is subject to the following two conditions: (1) This device may not cause harmful interference, and (2) this device must accept any interference received, including interference that may cause undesired operation.

- Reorient or relocate the receiving antenna.
- Increase the separation between the equipment and receiver.
- Connect the equipment to an outlet on a circuit that is different from the one to which the receiver is connected.
- Consult the dealer or an experienced radio/TV technician for help.
- **ICES (Canadian EMC Compliance Statement)**—This Class A digital apparatus complies with Canadian ICES-003.

**French translation:** Cet appareil numérique de la classe A est conforme à la norme NMB-003 du Canada.

- **Korean Communications Commission (KCC) Class A Statement**—This equipment is an electromagnetic compatible device for business purposes (Class A). The provider or user should be aware that the equipment is intended for use outside the home.

- **Thailand Regulation for Radio Communication Equipment:**



This regulation applies to ION 1200-S-C5G-WW device only.



*This radiocommunication equipment is exempted to possess license, user license, or radiocommunication station license as per NBTC notification regarding radiocommunication equipment and radiocommunication station has been exempted for license according to radio communication act B.E.2498).*

“เครื่องโทรคมนาคมและอุปกรณ์นี้มีความสอดคล้องตามมาตรฐานหรือข้อกำหนดทางเทคนิคของ กสทช.”

*“This telecommunication equipment conforms to the technical standards or requirements of NBTC.”*

“เครื่องวิทยุคมนาคมนี้มีระดับการแผ่คลื่นแม่เหล็กไฟฟ้าสอดคล้องตามมาตรฐานความปลอดภัยต่อสุขภาพของมนุษย์จากการใช้เครื่องวิทยุคมนาคมที่คณะกรรมการกิจการโทรคมนาคมแห่งชาติประกาศกำหนด”

*“This radiocommunication equipment has the electromagnetic field strength in compliance with the Safety Standard for the Use of Radiocommunication Equipment on Human Health announced by the National Telecommunications Commission.”*

- **Thailand Regulation for Non-Radio Equipment:**

เครื่องโทรคมนาคมและอุปกรณ์นี้มีความสอดคล้องตามมาตรฐานหรือข้อกำหนดทางเทคนิคของ กสทช.  
(This telecommunication equipment conforms to the technical standards or requirements of NBTC.)

- **Taiwanese Certification for Telecommunications Terminal Equipment**



*This regulation applies to ION 1200-C-5G-WW and ION ION 1200-S-C5G-WW devices only.*

- 減少電磁波影響，請妥適使用

Use the device appropriately to reduce the impact of electromagnetic waves.

- 電波功率密度 MPE 標準值：1mW/cm<sup>2</sup>，送測產品實測值：0.16mW/cm<sup>2</sup>，建議使用時設備天線至少距人體 20公分。

The standard value of radio wave power density MPE: 1mW/cm<sup>2</sup>, the actual measured value of the product sent for testing: 0.16mW/cm<sup>2</sup>, it is recommended that the device antenna be at least 20centimeters away from the human body when used.

- 為避免電磁干擾，本產品不應安裝或使用於住宅環境。

This product should not be installed or used in residential environments to avoid electromagnetic interference.

## Installation Kit Components

The ION 1200-S device installation kit contains the following parts and tools to install the device:

- 1x ION 1200-S device ships with 1x 150W power adapter.
- 1x Power adapter wall-mount kit (includes one power adapter bracket, a Velcro strap, and a plastic cable tie).
- 1x power cord, AC, which varies depending on the country or region.
- 1x Shielded RJ-45 CAT6 Ethernet cable.
- 3x Omni-directional Dipole Antennas for ION 1200-S-C-NA, and ION 1200-S-C-ROW.  
4x Omni-directional Dipole Antennas for ION 1200-S-C5G-WW.
- Sheet, Limited Warranty.



*Wall mount kit is not included in the ION 1200-S kit and must be ordered separately.*

The following optional hardware parts must be ordered separately:

- 1 x Region specific power cable.
- 1x Antenna cable kit for ION 1200-S-C-NA/ROW and ION 1200-S-C5G.
  - 1x ION 1200-S short antenna cable measuring 17"
  - 1x ION 1200-S long antenna cable measuring 27"

The long antenna cable connects to the front panel side (overlay) and the short cable connects to the back panel side.





*ION 1200-S-C-NA/ROW comes with 3 antenna cables and ION 1200-S-C5G-WW comes with 4 antenna cables in the rack mount kit.*

The following hardware parts can be ordered separately, if needed.

- 1x Power adapter.
- 1x USB to RJ-45 serial cable.







## ION 1200-S LEDs

Refer to the ION 1200-S device front panel images for position of the LEDs on the ION 1200-S devices and its description.

LEDs	ION 1200-S
Power 	<ul style="list-style-type: none"> <li>Green LED indicates the device is powered on.</li> <li>Red LED indicates that the device is not getting enough power.</li> </ul>
Operating System Status 	<ul style="list-style-type: none"> <li>Green LED indicates OS is running.</li> <li>Red LED indicates secure boot has failed.</li> </ul>
Controller 	<ul style="list-style-type: none"> <li>Green LED indicates that the device is connected to the controller.</li> <li>Red LED indicates the device is attempting to connect to the controller.</li> </ul>
Link Activity	On ethernet ports, the right LED displays the link activity. The LED blinks when there is activity detected on the link.
Link Speed	On ethernet ports, the left LED displays the link speed on the port. The LED blinks when there is speed detected on the link. <ul style="list-style-type: none"> <li>Off—No link or speed is 10Mbps.</li> <li>Green—Link detected and speed is 100Mbps.</li> <li>Yellow—Link detected and speed is 1Gbps.</li> </ul>

The following table describes the cellular LED.

Cellular LED	Cellular ION Device
Cellular	The device cellular LED indicates the signal strength. <ul style="list-style-type: none"> <li>Off—No modem detected.</li> </ul>

Cellular LED	Cellular ION Device
	<ul style="list-style-type: none"> <li>• Solid green LED indicates maximum signal strength.</li> </ul> <p>Blinking green LED indicates good to poor <a href="#">Radio Signal Strength Indicator</a>. The cellular LED blinking rate is based on the signal strength:</p> <ul style="list-style-type: none"> <li>• 25 blinks in 10 seconds—Good signal strength.</li> <li>• 10 blinks in 10 seconds—Fair signal strength.</li> <li>• 5 blinks in 10 seconds—Poor signal strength.</li> </ul> <p>You can also view the signal strength on the Interface tab of the Prisma SD-WAN web interface.</p> <ul style="list-style-type: none"> <li>- Excellent </li> <li>- Good </li> <li>- Fair </li> <li>- Poor </li> <li>- Modem Error, hover over the icon to see the error. </li> <li>- No modem or signal detected. </li> </ul>

## Power on the ION 1200

Connect the power cables to the ION device and plug the device power cable into an AC power outlet. When you switch on the power, the device powers on and the power indicator turns green.

## Restart the ION 1200

Press the power switch three times (press and hold for one second, and then release) to restart the device.

## Shut Down the ION 1200

Shut down the ION 1200 in the following ways:

- **Shut down using the Device Toolkit commands**

Run the device toolkit command `debug shutdown` to shut down the device.



*Ensure the device is physically accessible to turn it back on, before executing the command.*

- **Shut down using the Power Switch**

Press the power switch for more than five to eight seconds and then release to shut down the ION 1200 device.

When you shut down the device using the device CLI toolkit command or the power switch, click the power switch once to power on the device.

**Next Step:** [Configure the Cellular ION 1200.](#)



# Install ION 1200-S

This chapter explains the installation procedure for the ION 1200-s device:

- [Install Antennas in the ION 1200-S](#)
- [Insert SIM Cards in the ION 1200-S](#)
- [Install the ION 1200-S on a wall](#)
- [ION 1200-S Wall Mount Template](#)
- [Install the ION 1200-S on a Rack](#)

## Insert SIM Cards in the ION 1200-S

The ION 1200-S-C-NA, ION 1200-S-C-ROW, and ION 1200-S-C5G-WW devices support two SIM slots to enable multiple mobile network connectivity.

**STEP 1 |** Remove the SIM cover by unfastening the two M3 screws using a type one Phillips screwdriver.



**STEP 2 |** Insert the nano SIM in SIM 1 or SIM 2 slot by pushing the SIM in the slot till it is locked in its position.

The SIM chamfered corner (sloping edge) indicates the insertion orientation into the SIM slot as shown in figure below. Ensure to correctly insert the SIM in the SIM slot, incorrect insertion may damage the SIM.



*By default, SIM slot 1 is the primary SIM. If you have only one SIM, it is recommended to use the slot 1 as the primary SIM. If you want to use the SIM slot 2 as the primary SIM, you need to manually configure the SIM slot 2 as the primary SIM on the Prisma SD-WAN web interface.*



**STEP 3 |** After inserting the SIM, place the SIM cover back on the device.

To eject the SIM from the device, gently push the SIM inward using a finger tip and release it before pulling it out.

## Install Antennas in the ION 1200-S

The ION 1200-S-C-NA, ION 1200-S-C-ROW, and ION 1200-S-C5G-WW devices support multi-band antennas which can be easily secured to the device. The ION 1200-S-C-NA and ION 1200-S-C-ROW have three antenna SMA (F) connectors. The ION 1200-S-C5G-WW has four antenna SMA (F) connectors.

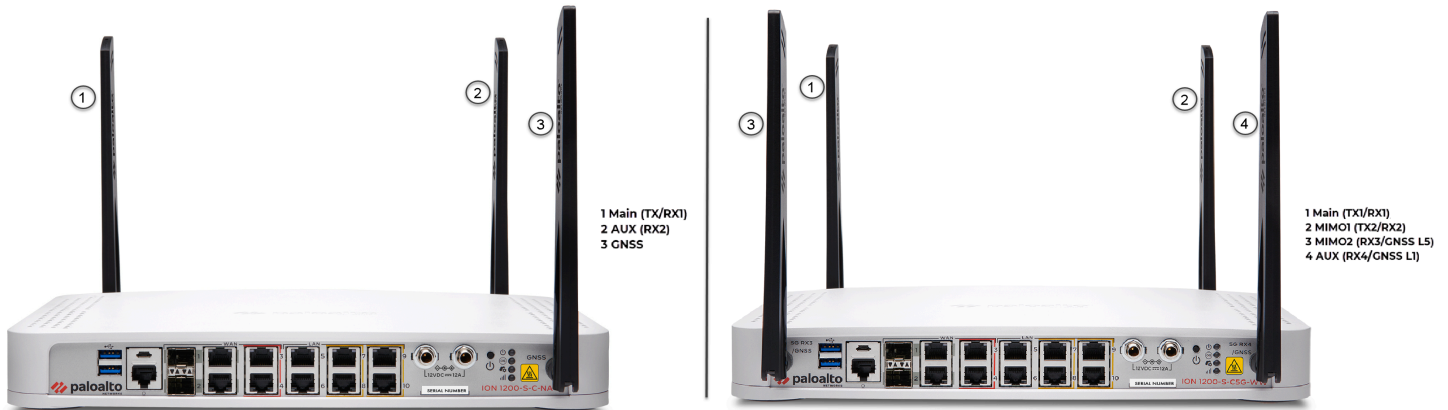

Feature	Description
Antennas	Multi-Band 4G / 5G Antenna 4G - 3x SMA Antenna connectors 5G - 4x SMA Antenna connectors
Frequency Range	615-960MHz / 1500-1600MHz / 1710-2690MHz / 3300-3700MHz
Peak Gain	2.3dBi in 800MHz band, 4.4dBi in 1575MHz band, 2.6dBi in 2170MHz band, 1.7dBi in 3300MHz band, 3.8dBi in 4400MHz band
VSWR	<3:1
Feed Impedance	50Ω
Power Handling	30 dBm
Interface	SMA (F) Connectors
Antenna Dimensions	229 mm x 28 mm x 14 mm (L x W x T)

**STEP 1 |** Secure the antennas to the SMA connectors located at the corners of the device.



Rotate the antennas at 180-degree movement about the SMA connectors. Tighten the antennas by hand.



**STEP 2 |** Adjust the antenna orientation to receive optimal signal strength in your environment.

-  *It is recommended to conduct a cellular location assessment of the site to receive best signal strength before installing the ION device.*

Position the antennas to receive optimal cellular signal strength. Check the signal strength on the ION device by viewing the [Cellular LED](#) signal strength indicator or on the Prisma SD-WAN web interface.

-  *Do not place the antennas close to, or pointing to one another, or layover one another.*
-  *Make sure the power cables do not cross over the antennas to avoid signal quality distortion and antenna performance degradation.*
-  *When installing the ION device on a wall or a desktop, it is recommended to orient the antennas upright and slanted slightly outwards, not exceeding 45 degrees, to improve the signal quality.*

## Install the ION 1200-S on a Flat Surface

The ION 1200-S series ships with rubber feet attached to each corner of the device. As pictured below, the ION 1200-S device can be horizontally situated on a flat surface.

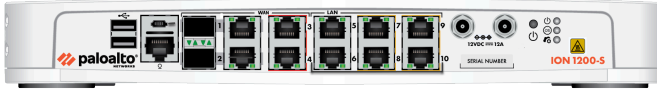

You can also install the ION 1200-S on a rack or a wall.

## Install the ION 1200-S on a wall

Install an ION 1200-S on a drywall or plywood wall using the wall-mount kit as described in the following procedure.

**STEP 1 |** Mark four locations on the wall that line up with the wall mount holes on the bottom of the device as shown in the [ION 1200-S Wall Mount Template](#).



Print the [ION 1200-S Wall Mount Template](#) on a US letter size sheet (8.5" x 11"), in portrait mode, and scale to actual size to ensure the screw hole markers line up correctly.



Ensure there are no building services (water, gas, or wiring) behind the wall where you intend to install the device.

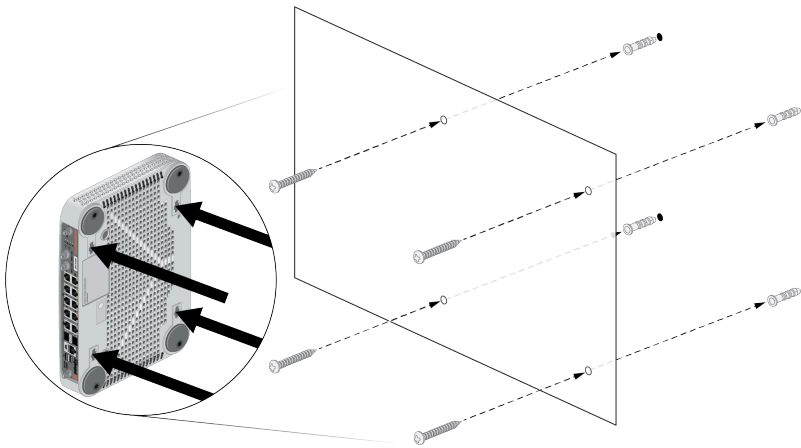

Screws and anchors are part of the wall-mount kit which is a separate kit option for the ION 1200-S.

**STEP 2 |** Use a #1 Phillips-head screwdriver to install the appropriate screws into each of the four marked locations:

- **Drywall**—Press a drywall anchor slightly into the center of a template mark. Then use the screwdriver to apply pressure while turning the anchor clockwise until the surface of the anchor is flush with the wall. After the drywall anchor is secure, install a 1.25" anchor screw into the anchor until the bottom of the screw head protrudes 1/4" (.6cm) from the wall. Repeat this step for the other three screw locations unless either is located over wood, in which case, use a .75" wood screw instead of a drywall anchor and screw.
- **Plywood wall**—Use the screwdriver to insert a .75" wood screw into the center of each template mark that is located over wood until the bottom of the screw heads protrude 1/4" (.6cm) from the wall.

**STEP 3 |** Align the four holes on the bottom of the device with the four screws on the wall and hang the device on the screws. Make sure the device is securely connected to each of the four screws before you let go.

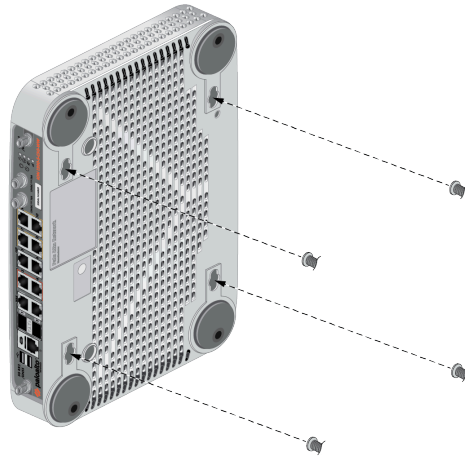

**STEP 4 |** Install the power adapter in the wall-mount bracket using the Velcro strap and cable tie. Make sure to align the cable tie with the notches in the bracket to prevent the power cord from falling out.

After you secure the power adapter to the bracket, mount the bracket next to the device using wood or drywall screws as appropriate.

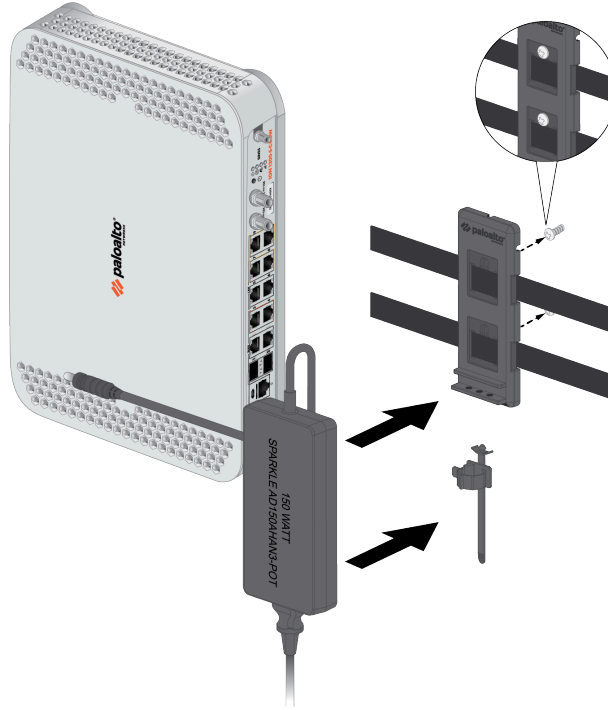

The following image shows a completed installation for an ION 1200-S with a single power adapter. If you need a second power supply, you need to order a power adapter and an adapter wall mount kit separately.

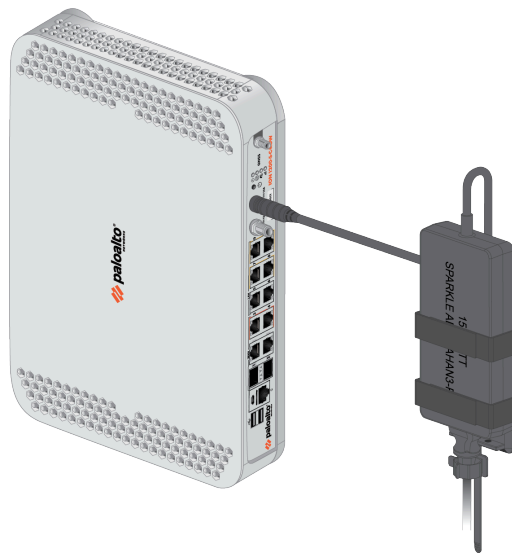

# ION 1200-S Wall Mount Template

Download and print the following wall mount template to secure the template to the wall where you intend to mount the ION 1200-S device and use it to mark the location for each of the four wall-mount screws.

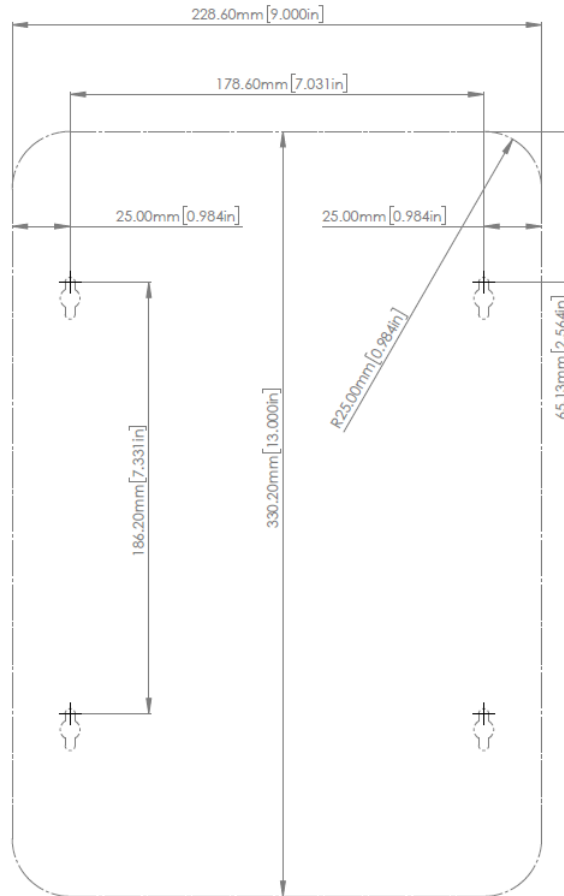

## Install the ION 1200-S on a Rack

Mount the ION device in a 19" equipment rack using the racktray. The mounting equipment requires 1 RU of rack space.

The racktray kit enables you to install an ION 1200-S device in a 19" rack. The installation hardware consists of a metal base and two rails. To ease installation, first install the device in the racktray and then install the assembled racktray into the equipment rack.



*For the rack mounted devices, the temperatures must not exceed a specified maximum ambient temperature of 40 degrees Celsius. If there is any other heat source in the rack, you may need to add some form of ventilation such as fans or thermal pads to prevent internal thermal buildup.*



*Maintain a minimum of 7.5" height clearance for the antennas in the rack.*

**STEP 1 |** Slide one of the adjustable mounting brackets into one of the fixed mounting brackets to create a mounting rail. Repeat for the second mounting rail. The adjustable and fixed brackets are the same for the left and right side.

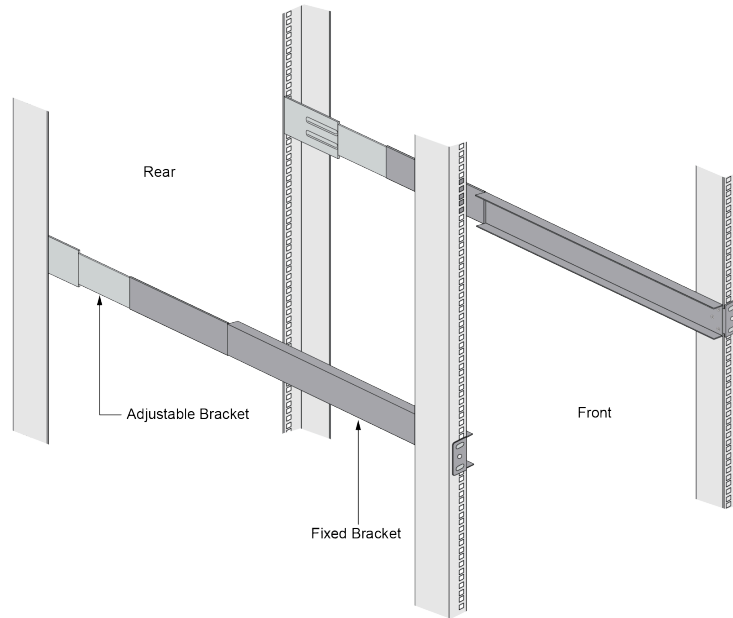

You may also use the two-post configuration to rack mount the device using a cross-bar at the rear to prevent the racks from flaring out. This kit can be used for ION 1200 and its variants.

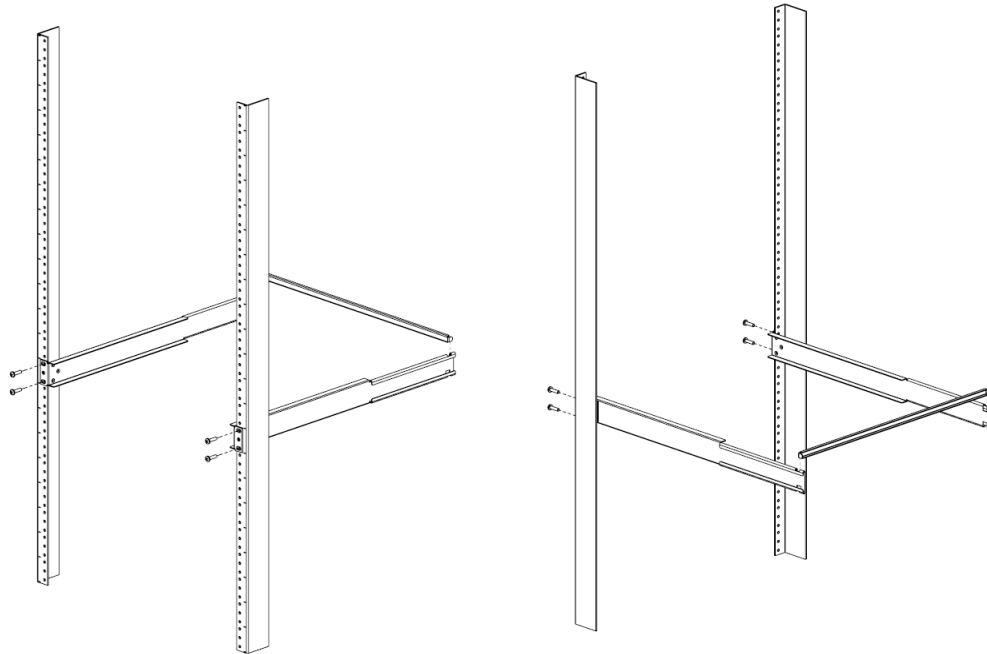

The following is the cable rack mount kit for ION 1200-S-C-NA, ION 1200-S-C-ROW, and ION 1200-S-C5G-WW.

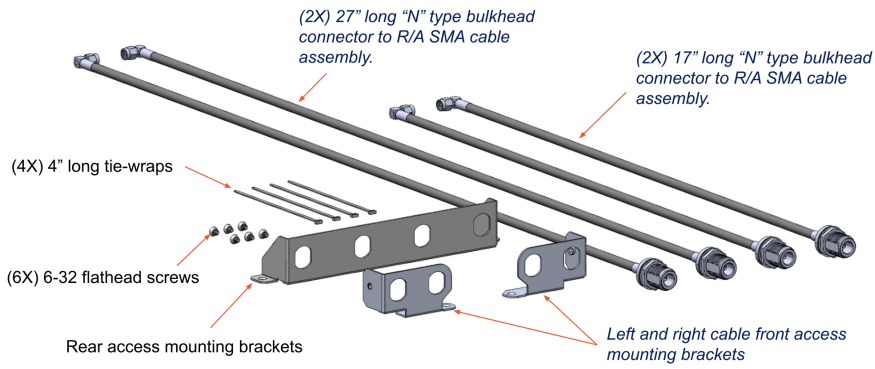

**STEP 2 |** Align the bottom edge of the mounting rails to the bottom of the 1 RU rack space reserved for the device. Align the slotted holes in the adjustable mounting bracket to the holes on the rear of the equipment frame.



*The mounting rails are designed for equipment frames that are 26" to 32" deep.*

**STEP 3 |** Secure the rails to the equipment frame with mounting screws (not provided) compatible with your equipment frame. Tighten the screws to their recommended torque value.

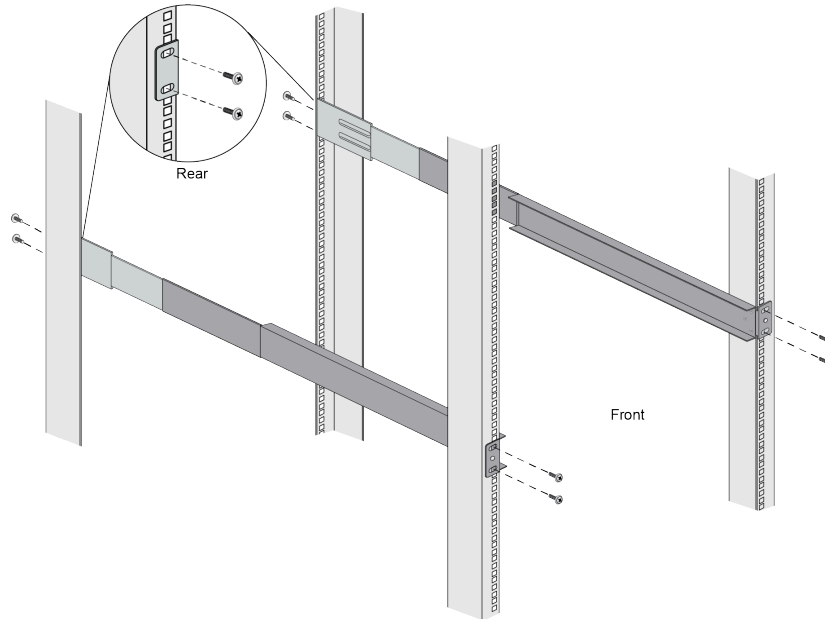

**STEP 4 |** Slide the power adapter into the marked position and attach the AC cord, route the AC cord to the right side of the tray sidewall and underneath the front tray "C" channel.

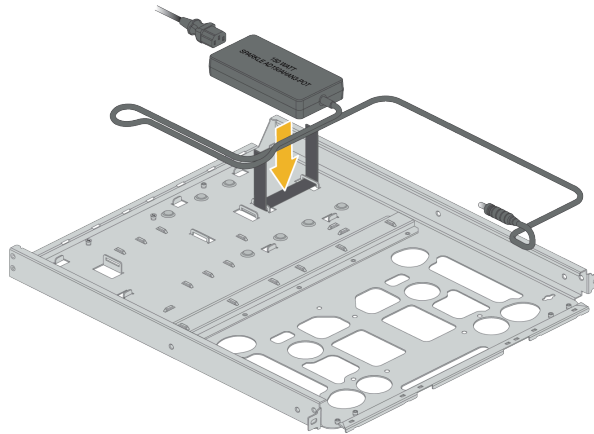

**STEP 5 |** Attach the power cord routing cover to the tray sidewall and install AC retaining clamp.

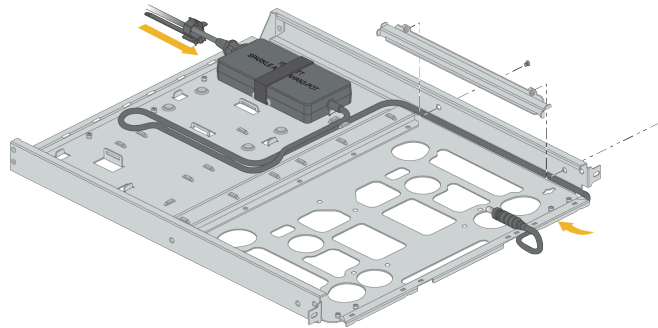

**STEP 6 |** Plug the power supply connector into the back of the device. Using the provided tie-wraps, bind and secure the power supply cable toward the back end of the tray using the sheet-metal lances toward the center of the tray.

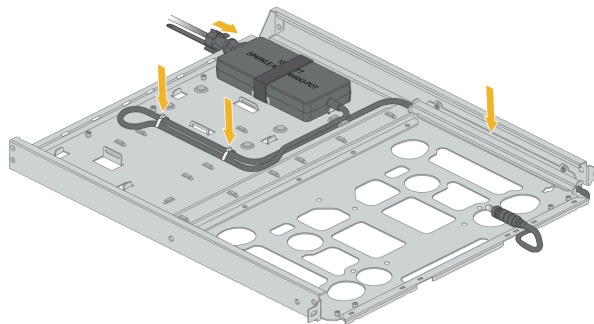

**STEP 7 |** After assembling the device to the tray and connecting the power cable to the device, tie-wrap the power cord to the "C" channel.

- STEP 8 |** With the front of the device facing forward, align the four rubber feet on the bottom of the device to the slotted holes in the provided mounting tray. Secure the device in place using two provided #6-32 x 3/16" Long Flathead screws.

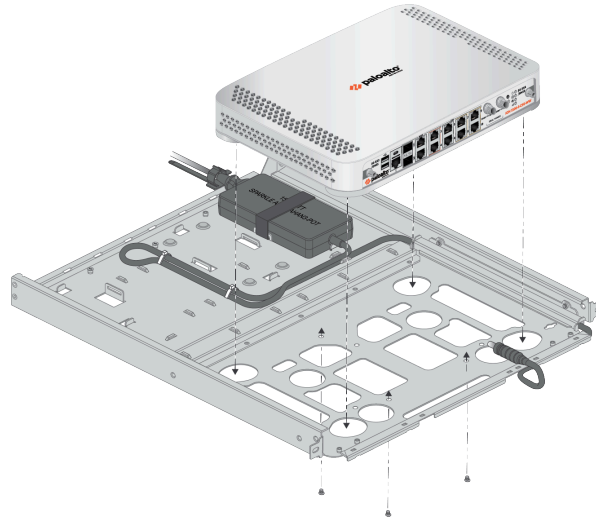

- STEP 9 |** Slide the mounting tray into the rails previously fixed to the equipment rack. Stop when the front flange on the mounting tray is flush with the front of the rail.

- STEP 10 |** Align the slotted holes in the mounting tray to the holes in the equipment frame. Secure the mounting tray to the equipment frame on both sides using 3 screws each (not provided). The screws must be compatible with your equipment frame.

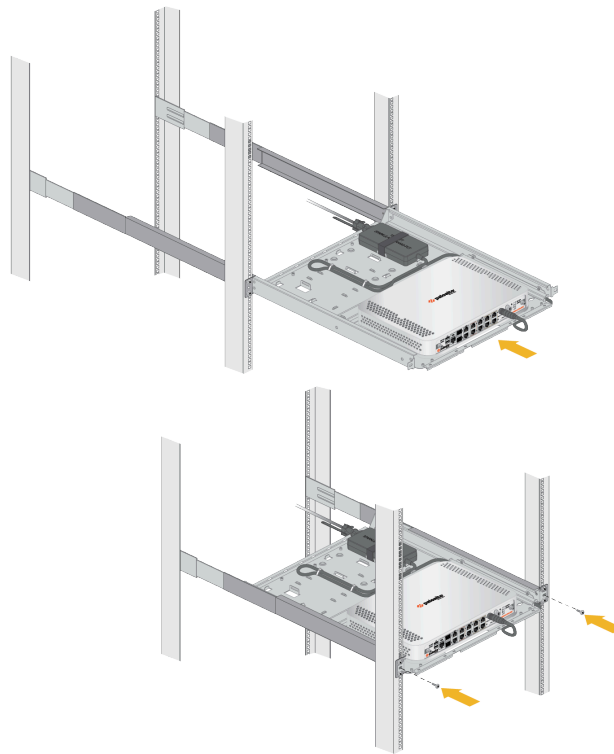

- STEP 11 |** Proceed to [Power on the ION 1200](#)

# Troubleshoot ION 1200-S Series

This section lists the most common issues that you may face. Troubleshoot the issue by following the resolution steps mentioned in the table.

- [Troubleshoot Common Issues with the ION 1200-S Series](#)

# Troubleshoot Common Issues with the ION 1200-S Series

**Alerts and Incidents** are reported when there is fault in the system or an issue with the cellular modem.

Troubleshoot the issue by following the resolution steps mentioned in the table. If the issue persists, contact Palo Alto Networks Support.

Issue	Resolution
<p>No radio signal - The cellular module in the ION device cannot detect a radio signal from the internet service provider network.</p>	<ol style="list-style-type: none"> <li>1. Check the modem status.</li> <li>2. Check the radio status.</li> <li>3. Check the antenna connectivity.</li> <li>4. Check if the SIM card is properly installed.</li> <li>5. Check if you are in your network provider's coverage area.</li> </ol>
<p>Weak radio signal - reception on your modem is poor.</p>	<ol style="list-style-type: none"> <li>1. Check the antenna connectivity.</li> <li>2. Try to move the router to a different location where there are fewer or no obstacles to the signal (for example, near a window).</li> </ol> <p>Keep the device away from large metal objects, such as ducts, mirrors, appliances, and elevators. Minimize the number of walls between the unit and base station. Avoid any cables in proximity to the antennas.</p>
<p>No internet access</p>	<ol style="list-style-type: none"> <li>1. Check the modem status.</li> <li>2. Check the radio status.</li> <li>3. Check the SIM status.</li> <li>4. Make sure that a SIM card is installed in the modem. Check with your mobile broadband service provider to ensure that good coverage exists in the area.</li> <li>5. Make sure that your mobile broadband account is active.</li> <li>6. If there is no mobile broadband coverage, the Signal Strength LED is off. If there is poor signal strength, move the modem closer to a window for better access to the mobile broadband signal.</li> <li>7. Check to see if your mobile service provider is experiencing network problems. There may be</li> </ol>

Issue	Resolution
	<p>issues with the service provider rather than your modem.</p> <ol style="list-style-type: none"> <li>8. You might need to add a custom or a private APN profile. Contact your mobile broadband service provider for APN information.</li> </ol>
<p>Interface flapping</p>	<ol style="list-style-type: none"> <li>1. Check the Signal Strength LED.</li> <li>2. If you see only one or two <a href="#">signal strength bars</a>, move the modem closer to a window for better access to the mobile broadband signal.</li> </ol>
<p>Slow download or upload speed</p> <p>Data transfer speed depends on signal strength and interfering radio sources and technology it is connected to.</p>	<ol style="list-style-type: none"> <li>1. Check the antenna connection.</li> <li>2. Check the RAT modem connection; (for example, LTE 4G is generally faster than 3G).</li> <li>3. Try to move the router to a different location where there is less or no obstacles to the signal; (for example, near a window).</li> <li>4. Check for obstacles to the signal and interference from other devices.</li> </ol>
<p>Attached no IP address</p>	<p>If your modem cannot access the internet but one or more Signal Strength LED bars are green, see if the modem can obtain an internet IP address from the mobile broadband service provider. Modem requests an IP address from the mobile broadband service provider. You can determine whether the request was successful from Alerts or Notifications on the portal.</p> <ol style="list-style-type: none"> <li>1. Make sure that an APN profile exists and selected as an active profile, in case of custom APN.</li> <li>2. Turn the radio off and then turn it back on.</li> <li>3. Turn modem off and on. If you still cannot obtain an internet IP address, contact your mobile broadband service provider.</li> </ol>
<p>No power in the PoE ports.</p>	<ol style="list-style-type: none"> <li>1. Confirm whether the powered device (PD) on the PoE port is attached properly.</li> <li>2. If PD is attached but not receiving power, check if PoE is enabled on the port, port is administratively enabled and whether device budget permits powering on the PD.</li> </ol>
<p>Power Sourcing Equipment (PSE) controller encounters an internal error requiring a reload/power-cycle/RMA of the device.</p>	<ol style="list-style-type: none"> <li>1. Recover the device.</li> <li>2. Check if a reload of the device or a power-cycle helps to recover the device.</li> </ol>

Issue	Resolution
	<b>3.</b> Call Palo Alto Networks support if the issue is still not resolved.
The main power usage goes over the configured threshold for the system or for a port.	Check the PD power requirements for the port and all the PDs. Validate whether the power usage for the port and all the PDs is as expected and is over the configured threshold for the device.