

THIS COPY IS PROVIDED ON A RESTRICTED BASIS AND IS NOT TO BE USED IN ANY WAY DETRIMENTAL TO THE INTERESTS OF PANDUIT CORP.

UPPER SIDE
PANEL

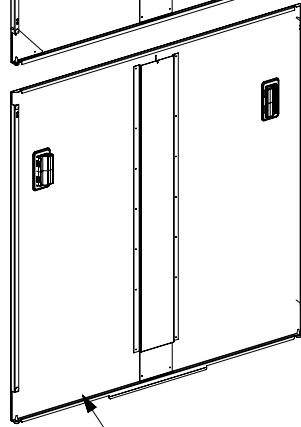

LOWER SIDE
PANEL

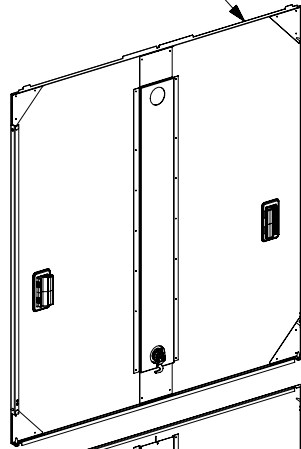
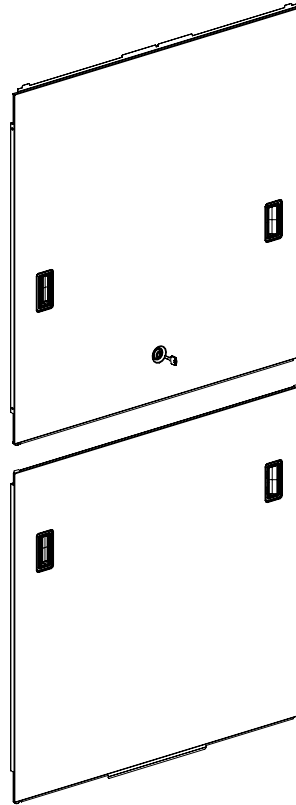

NOTES:

1. VISIT OUR ON-LINE CATALOG AT WWW.PANDUIT.COM FOR A LIST OF CURRENT PARTS APPLICABLE FOR USE WITH THIS PRODUCT.
2. PRIMARY DIMENSIONS ARE IN MILLIMETERS.
3. PARTS SUPPLIED:
 (1) LOWER SIDE PANEL
 (1) UPPER SIDE PANEL
 (2) KEYS
 (1) INSTALLATION INSTRUCTIONS (NOT SHOWN)

REV	DATE	BY	CHK	APR	DESCRIPTION	ECN
02A	2/20/23	MEX-JAGC	RAMA	ELE	ADDED 52RU SIZES, REMOVED SOME COMPONENTS FROM PARTS SUPPLIED AND VIEWS	V09002EQ/14
00A	2/18/21	MEX-JAGC	SSP	ELE	DRAWING RELEASE	V09002EQ/08

TITLE FLEXFUSION™ SIDE PANEL (XG-SPFS***B & XG-SPFS***W) CUSTOMER DRAWING					
ITEM REVISION NAME 00461EPN/02				PANDUIT	
DATASET FILE NAME 00461EPN_DC/02A					
MATERIAL: N/A					
DRAWING NUMBER: 00461EPN-DC					
DRAWN BY MEX-JAGC	DATE 2/18/21	CHK SSP	SCALE NONE	THIRD ANGLE PROJECTION	
SHT 1 OF 2				SIZE A	

N\GLOBAL_AS\SIZE

THIS COPY IS PROVIDED ON A RESTRICTED BASIS AND IS NOT TO BE USED IN ANY WAY DETRIMENTAL TO THE INTERESTS OF PANDUIT CORP.

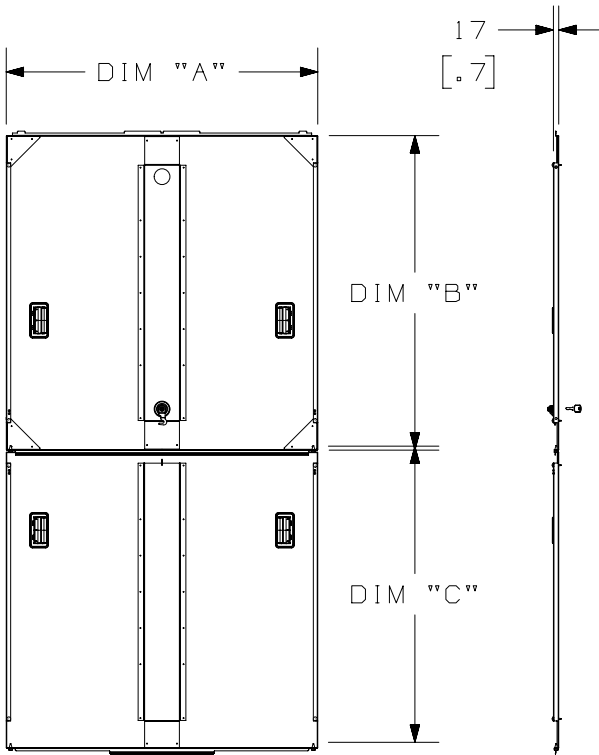

PANDUIT PART NO.	DESCRIPTION	DIM "A"	DIM "B"	DIM "C"	WEIGHT
XG-SPFS421*	FLEXFUSION 42RU x 1070mm DEPTH SIDE PANEL	989 [38.9]	999 [39.3]	940 [37.0]	18.8 Kg/EACH 41.55 LBS/EACH
XG-SPFS422*	FLEXFUSION 42RU x 1200mm DEPTH SIDE PANEL	1139 [44.8]			21.2 Kg/EACH 46.77 LBS/EACH
XG-SPFS451*	FLEXFUSION 45RU x 1070mm DEPTH SIDE PANEL	989 [38.9]	1065 [41.9]	1007 [39.6]	20.1 Kg/EACH 44.33 LBS/EACH
XG-SPFS452*	FLEXFUSION 45RU x 1200mm DEPTH SIDE PANEL	1139 [44.8]			22.6 Kg/EACH 49.89 LBS/EACH
XG-SPFS481*	FLEXFUSION 48RU x 1070mm DEPTH SIDE PANEL	989 [38.9]	1132 [44.6]	1074 [42.3]	21.4 Kg/EACH 47.10 LBS/EACH
XG-SPFS482*	FLEXFUSION 48RU x 1200mm DEPTH SIDE PANEL	1139 [44.8]			24.1 Kg/EACH 53.10 LBS/EACH
XG-SPFS511*	FLEXFUSION 51RU x 1070mm DEPTH SIDE PANEL	989 [38.9]	1199 [47.2]	1140 [44.9]	22.6 Kg/EACH 49.88 LBS/EACH
XG-SPFS512*	FLEXFUSION 51RU x 1200mm DEPTH SIDE PANEL	1139 [44.8]			25.5 Kg/EACH 56.13 LBS/EACH
XG-SPFS521*	FLEXFUSION 52RU x 1070mm DEPTH SIDE PANEL	989 [38.9]	1221 [48.1]	1163 [45.8]	22.8 Kg/EACH 50.27 LBS/EACH
XG-SPFS522*	FLEXFUSION 52RU x 1200mm DEPTH SIDE PANEL	1139 [44.8]			25.7 Kg/EACH 56.65 LBS/EACH

* DENOTES COLOR
ADD SUFFIX "B" FOR BLACK AND "W" FOR WHITE.

REV	DATE	BY	CHK	APR	DESCRIPTION	ECN
02A	2/20/23	MEX-JAGC	RAMA	ELE	SEE SHEET 1 FOR REVISIONS	V09002EQ/14
00A	2/18/21	MEX-JAGC	SSP	ELE	DRAWING RELEASE	V09002EQ/08

TITLE FLEXFUSION™ SIDE PANEL (XG-SPFS***B & XG-SPFS***W) CUSTOMER DRAWING						
ITEM REVISION NAME 00461EPN/02			PANDUIT			
DATASET FILE NAME 00461EPN_DC/02A						
MATERIAL: N/A			DRAWING NUMBER: 00461EPN-DC			
DRAWN BY MEX-JAGC		DATE 2/18/21	CHK SSP	SCALE NONE	SHT 2 OF 2	SIZE A

N\GLOBAL_AS\SIZE