

SRX1600 Firewall Hardware Guide

Published
2025-09-10

Juniper Networks, Inc.
1133 Innovation Way
Sunnyvale, California 94089
USA
408-745-2000
www.juniper.net

Juniper Networks, the Juniper Networks logo, Juniper, and Junos are registered trademarks of Juniper Networks, Inc. in the United States and other countries. All other trademarks, service marks, registered marks, or registered service marks are the property of their respective owners.

Juniper Networks assumes no responsibility for any inaccuracies in this document. Juniper Networks reserves the right to change, modify, transfer, or otherwise revise this publication without notice.

SRX1600 Firewall Hardware Guide

Copyright © 2025 Juniper Networks, Inc. All rights reserved.

The information in this document is current as of the date on the title page.

YEAR 2000 NOTICE

Juniper Networks hardware and software products are Year 2000 compliant. Junos OS has no known time-related limitations through the year 2038. However, the NTP application is known to have some difficulty in the year 2036.

END USER LICENSE AGREEMENT

The Juniper Networks product that is the subject of this technical documentation consists of (or is intended for use with) Juniper Networks software. Use of such software is subject to the terms and conditions of the End User License Agreement ("EULA") posted at <https://support.juniper.net/support/eula/>. By downloading, installing or using such software, you agree to the terms and conditions of that EULA.

Table of Contents

About This Guide | vii

1

Fast Track: Initial Installation

Fast Track to Rack Installation and Power | 2

Install the SRX1600 in a Rack | 2

Connect to Power | 4

Claim, Onboard, and Configure SRX1600 | 6

2

Overview

SRX1600 Firewall Overview | 9

SRX1600 Chassis | 11

Chassis Physical Specifications for SRX1600 | 11

Front Panel of the SRX1600 | 12

Rear Panel of the SRX1600 | 13

Chassis Status LEDs | 15

Management Port LEDs | 17

Network Port LEDs | 18

Cooling System and Airflow in the SRX1600 | 21

SRX1600 Power System | 24

3

Site Planning, Preparation, and Specifications

Site Preparation Checklist for SRX1600 | 33

SRX1600 Site Guidelines and Requirements | 34

General Site Installation Guidelines | 35

Site Electrical Wiring Guidelines | 35

Environmental Requirements and Specifications for SRX1600 | 36

Clearance Requirements for Hardware Maintenance of the SRX1600 | 37

Rack Requirements for the SRX1600 | 38

Cable Specifications and Pinouts for SRX1600 | 40

Transceiver Support for SRX1600 | 40

RJ-45 Connector Pinouts for the SRX1600 Firewall Management Port | 40

RJ-45 Connector Pinouts for the SRX1600 Firewall Console Port | 41

4

Initial Installation and Configuration

SRX1600 Installation Overview | 44

Unpack the SRX1600 | 44

Tools and Parts Required to Unpack the SRX1600 | 44

Unpack an SRX1600 | 45

Verify Parts Received with the SRX1600 | 45

Install the SRX1600 in a Rack | 46

Mount your Device by Using the JNP-4P-TL-1RU-RMK Rack Mount Kit on a Square Hole 4-Post Rack | 47

Mount your Device by Using the JNP-4P-TL-1RU-RMK Rack Mount Kit on a Threaded-Hole 4-Post Rack | 50

Connect the SRX1600 to Power | 56

Connect Earth Ground to the SRX1600 | 56

Connect AC Power to the SRX1600 | 58

Connect DC Power to the SRX1600 | 60

Power Off the SRX1600 | 62

Connect the SRX1600 to External Devices | 63

Connect the to a Network for Out-of-Band Management | 64

Connect the to a Management Console Using an RJ-45 Connector | 64

Register Products—Mandatory to Validate SLAs | 65

Configure Junos OS on the SRX1600 | 66

Configure the SRX1600 Using J-Web | 66

Configure the SRX1600 using Juniper Security Director Cloud | 67

Access the CLI on the SRX1600 | 68

Configure Root Authentication and Management Interface from the CLI | 68

Factory-Default Configuration of the SRX1600 | 70

View the SRX1600 Factory-Default Configuration | 70

5

Maintaining Components

Routine Maintenance Procedures for the SRX1600 | 72

SRX1600 Cooling System Maintenance | 72

Remove the Fan Module from the SRX1600 | 73

Install the Fan Module in the SRX1600 | 73

SRX1600 Power Supply Maintenance | 74

Replace an AC PSU on the SRX1600 | 75

Remove the AC PSU from the SRX1600 | 75

Install the AC PSU in the SRX1600 | 76

Replace a DC PSU on the SRX1600 | 77

Remove the DC PSU from an SRX1600 | 77

Install the DC PSU in the SRX1600 | 78

6

Troubleshooting Hardware

Troubleshoot the SRX1600 | 81

Troubleshooting Resources for the SRX1600 Firewall | 81

Troubleshooting Chassis and Interface Alarm Messages on the SRX1600 Firewall | 81

Troubleshooting the Power System on the SRX1600 | 83

Using the RESET Button | 84

7

Contact Customer Support and Returning the Chassis or Components

Contacting Customer Support and Returning the Chassis or Components | 87

How to Return a Hardware Component to Juniper Networks | 87

Locate the Chassis Serial Number ID Label | 88

Contact Customer Support to Obtain Return Material Authorization | 89

| Guidelines for Packing and Shipping Hardware Components | 90



Safety and Compliance Information

Safety Information | 92

SRX1600 Agency Approvals | 93

About This Guide

Use this guide to install the hardware and perform initial software configuration, routine maintenance, and troubleshooting for the Juniper Networks® SRX1600 Firewall. After completing the installation and basic configuration procedures covered in this guide, you can refer to the Junos® OS documentation for information about further software configuration.

1

CHAPTER

Fast Track: Initial Installation

IN THIS CHAPTER

- [Fast Track to Rack Installation and Power | 2](#)
 - [Claim, Onboard, and Configure SRX1600 | 6](#)
-

Fast Track to Rack Installation and Power

SUMMARY

This procedure guides you through the simplest steps to install your SRX1600 Firewall in a rack and connect it to power. Have more complex installation needs? See ["Install the SRX1600 in a Rack" on page 46](#).

IN THIS SECTION

- [Install the SRX1600 in a Rack | 2](#)
- [Connect to Power | 4](#)

Install the SRX1600 in a Rack

You can install the SRX1600 Firewall in a four-post rack or cabinet. We'll walk you through the steps to install an AC-powered firewall in a square-hole four-post rack.

Before you install, review the following:

- ["SRX1600 Site Guidelines and Requirements" on page 34](#).
 - [General Safety Guidelines and Warnings](#).
 - ["Unpack the SRX1600" on page 44](#).
1. Wrap and fasten one end of the electrostatic discharge (ESD) cable grounding strap around your bare wrist, and connect the other end to a site ESD point.
 2. Attach the side-mounting brackets to the chassis. Align the keyholes of the mounting brackets over the shoulder screws of the chassis and slide the mounting brackets towards the rear of the chassis.

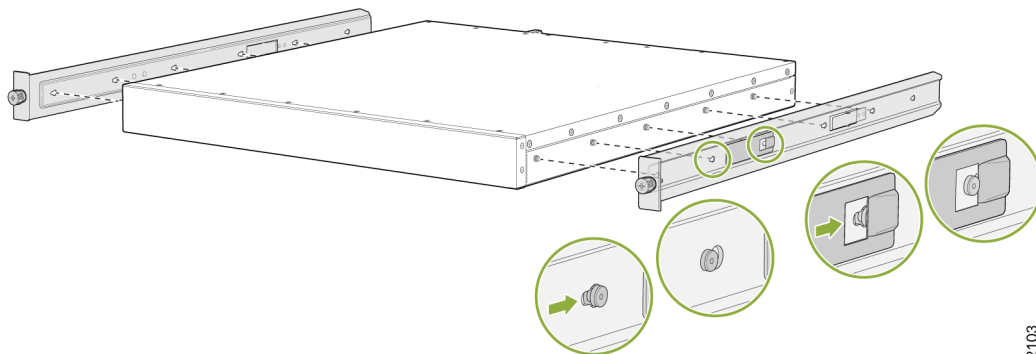

3. Assemble the mounting rails by sliding the rear rails into the front rails.

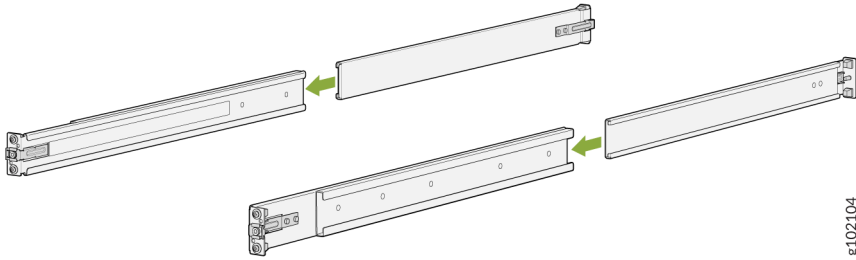

g102104

4. Align the guide blocks of the rear-mounting rail with the rear-post holes. Pull the rear-mounting rail toward the front of the rack to lock the rail in place. You'll hear a distinct click when the latch locks into the rack holes.

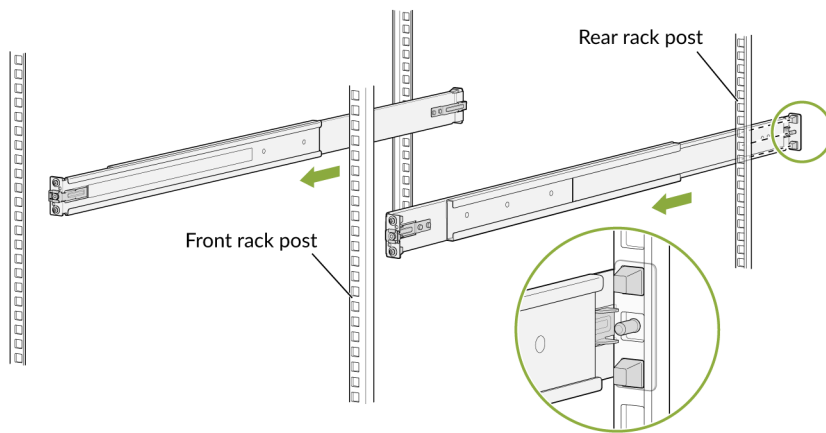

g102105

5. Align the guide blocks of the front-mounting rail with the front-post holes. Push the front-mounting rail toward the rear of the rack to lock the rail in place. You'll hear a distinct click when the latch locks into the rack holes.

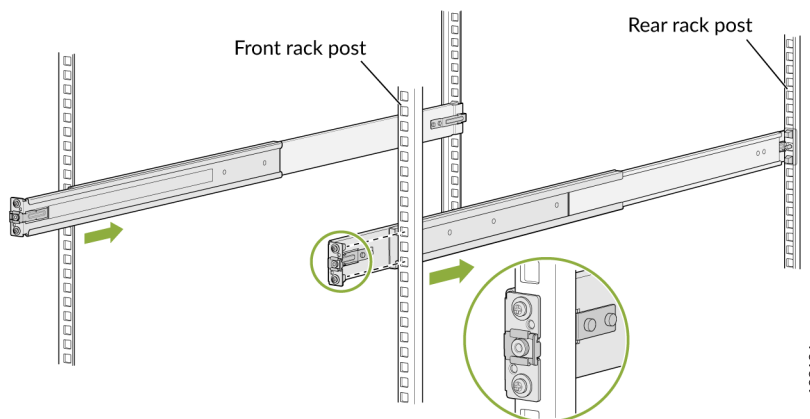

g102106

6. Ensure that the front and rear latches on the mounting rails are locked in place.

7. Lift the device and position it in the rack, aligning the side-mounting brackets with the mounting rails. Slide the device into the channels of the mounting rails.

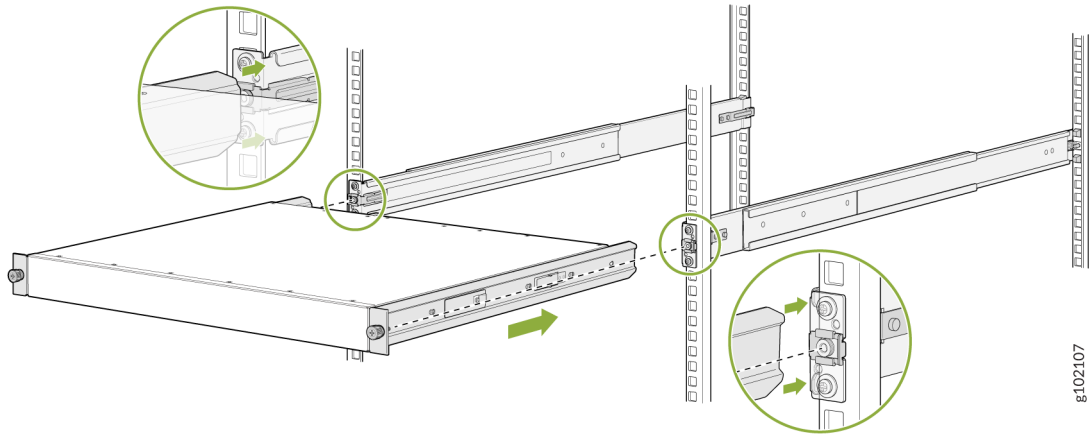

8. Tighten the two thumbscrews to secure the device.

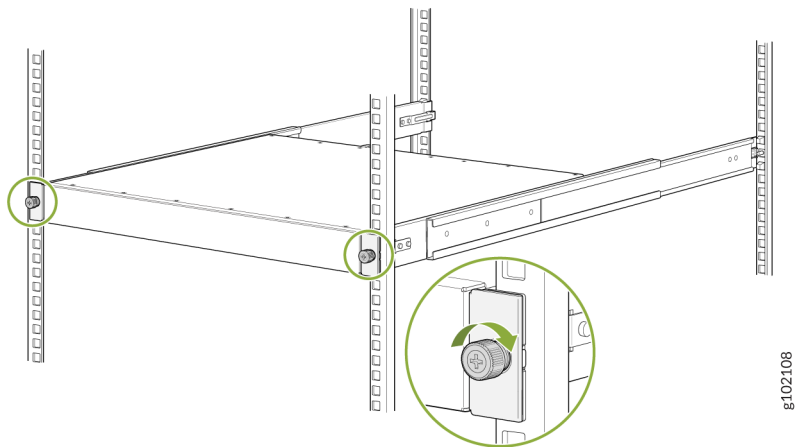

Connect to Power

IN THIS SECTION

- [Ground the SRX1600 Firewall | 5](#)
- [Connect the Power Cord and Power On the Firewall | 5](#)

To connect the SRX1600 Firewall to AC power, you must do the following:

Ground the SRX1600 Firewall

To ground the SRX1600 Firewall, do the following:

1. Wrap and fasten one end of the electrostatic discharge (ESD) cable grounding strap around your bare wrist, and connect the other end to a site ESD point.
2. Connect the grounding cable to a proper earth ground, such as the rack in which you mount the device.
3. Place the grounding cable terminal attached to the grounding cable over the grounding point.
4. Secure the grounding cable terminal to the grounding point using the M5 screws.

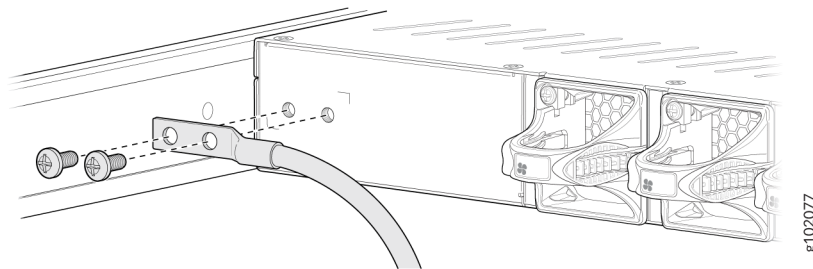

5. Dress the grounding cable. Ensure that the cable doesn't block access to or come in contact with other device components, and that it doesn't drape where people could trip over it.

Connect the Power Cord and Power On the Firewall

For information about the supported AC power cord specifications, see ["Supported AC Power Cords" on page 26](#).

To connect the power cord, do the following:

1. Ensure that the power supply is fully inserted in the rear panel of the firewall.
2. Insert the coupler end of the power cord into the AC power cord socket on the rear panel.
3. Push the power cord retainer on to the power cord.

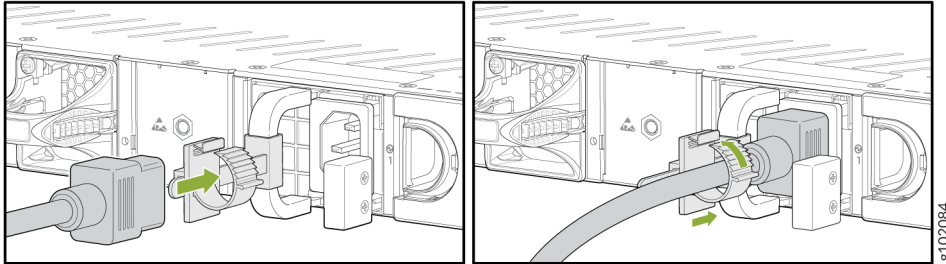

4. If the AC power source outlet has a power switch, turn it off.
5. Plug the power cord into an AC power source outlet.
6. If the AC power source outlet has a power switch, turn it on. The firewall doesn't have a power switch and powers on as soon as you plug it in.

Claim, Onboard, and Configure SRX1600

SUMMARY

This topic provides you the pointers to onboard and configure SRX1600 firewalls using Juniper® Security Director, or configure SRX1600 firewalls using J-Web or Junos OS CLI.

If you have a Juniper® Security Director license, you can follow a few simple steps to get an SRX1600 up and running on the Juniper® Security Director Cloud portal. See [Table 1 on page 6](#) for more information.

Table 1: Onboard and Configure SRX1600 Using Juniper® Security Director

If you want to	Then
Claim and onboard to Juniper® Security Director Cloud	See Onboard SRX Series Firewalls to Security Director Cloud
Configure additional features	See Juniper Security Director Cloud User Guide

You can configure the SRX1600 using the J-Web GUI. See [Table 2 on page 7](#) for more information.

Table 2: Configure SRX1600 Using J-Web

If you want to	Then
Customize basic configuration	See "Configure the SRX1600 Using J-Web " on page 66
Configure additional features using J-Web	See J-Web for SRX Series Documentation
Set up your SRX1600 with advanced security measures to protect and defend your network	See SRX Series Up and Running with Advanced Security Features
See, automate, and protect your network with Juniper Security	Visit the Security Design Center
Download, activate, and manage your software licenses to unlock additional features for your SRX firewall	See Activate Junos Licenses in the Juniper Licensing Guide

You can also configure the SRX1600 using the Junos OS CLI. See [Table 3 on page 7](#) for more information.

Table 3: Configure SRX1600 Using Junos OS CLI

If you want to	Then
Customize basic configuration	See "Configure Root Authentication and Management Interface from the CLI" on page 68
Explore the software features supported on the SRX1600	See Feature Explorer
Configure Junos features on the SRX1600	See User Guides

2

CHAPTER

Overview

IN THIS CHAPTER

- SRX1600 Firewall Overview | 9
 - SRX1600 Chassis | 11
 - Cooling System and Airflow in the SRX1600 | 21
 - SRX1600 Power System | 24
-

SRX1600 Firewall Overview

IN THIS SECTION

- [SRX1600 Firewall Overview | 9](#)
- [Field-Replaceable Units in SRX1600 | 10](#)
- [Benefits of the SRX1600 | 10](#)

SRX1600 Firewall Overview

The SRX1600 Firewall is an entry-level firewall that consolidates firewall and security features. The SRX1600 is ideal for small to medium enterprise edge, campus edge, data center edge, and secure VPN router deployments for distributed enterprise use cases.

The SRX1600 is a 1-U chassis with the following port configurations:

- Sixteen 1 Gigabit-Ethernet (GbE) BASE-T ports
- Four 10 GbE SFP+ MACsec ports
- Two 25 GbE SFP28 MACsec ports
- Two 1 GbE SFP High Availability (HA) MACsec ports

We ship the SRX1600 with a 120 GB SSD that is not field-replaceable.

The SRX1600 runs Junos OS and provides next-generation firewall capabilities including Application ID (AppID), User Firewall (UserFW), intrusion prevention system (IP), Content Security, etc. It also provides advanced threat detection and mitigation capabilities through Juniper® Advanced Threat Prevention (Juniper ATP Cloud) .

You can manage the SRX1600 using Juniper® Security Director on Premise, Juniper® Security Director Cloud, J-Web, and the CLI.

Field-Replaceable Units in SRX1600

Field-replaceable units (FRUs) are components that you can replace at your site. The SRX1600 supports the following FRUs:

- Fan modules
- Power supply units (PSUs)
- Transceivers

You can remove and replace the power supply units, fan modules, and transceivers without powering off the device or disrupting the device functions.



CAUTION: Replace a failed PSU with a new PSU within five minutes of removal to maintain power redundancy. The router continues to operate with only one PSU running.

Replace a failed fan module with a new fan module within five minutes of removal to prevent chassis overheating.

Benefits of the SRX1600

- **High Performance**—The SRX1600 integrates carrier-class routing and feature rich switching in a single platform. It supports up to 8 Gbps of Internet Mix (IMIX) firewall throughput. You can install the SRX1600 in enterprise edge, campus edge, and data center edge deployments.
- **Next-Generation Firewall**—The SRX1600 offers 7.5 Gbps of next-generation firewall, 8 Gbps of IPS, and up to 5 Gbps of IPsec VPN in deployments with IMIX traffic.
- **Advanced threat protection**—You can secure your network with Juniper ATP Cloud integrated with the SRX1600. Juniper ATP Cloud provides advanced threat mitigation and detection capabilities, which help protect your network against potential vulnerabilities such as zero-day attacks and other unknown threats.

SRX1600 Chassis

IN THIS SECTION

- Chassis Physical Specifications for SRX1600 | 11
- Front Panel of the SRX1600 | 12
- Rear Panel of the SRX1600 | 13
- Chassis Status LEDs | 15
- Management Port LEDs | 17
- Network Port LEDs | 18

The SRX1600 firewall chassis is a rigid sheet metal structure that houses all the other hardware components.

Chassis Physical Specifications for SRX1600

The SRX1600 firewall has a 1-U form factor and you can be install it in a standard 19 in. rack. [Table 4 on page 11](#) summarizes the physical specifications of the SRX1600.

Table 4: Physical Specifications of SRX1600

Model	Height	Width	Depth	Weight
SRX1600	1.74 in. (4.42 cm)	17.28 in. (43.89 cm)	18.20 in. (46.23 cm)	15.90 lb (7.2 kg)



NOTE: We ship the SRX1600 with only one power supply unit (PSU). The weight of an SRX1600 device configured with 2 PSUs is 17.86 lb (8.1 kg).

Front Panel of the SRX1600

Figure 1 on page 12 shows the front panel of an SRX1600 firewall.

Figure 1: Front Panel Components of the SRX1600

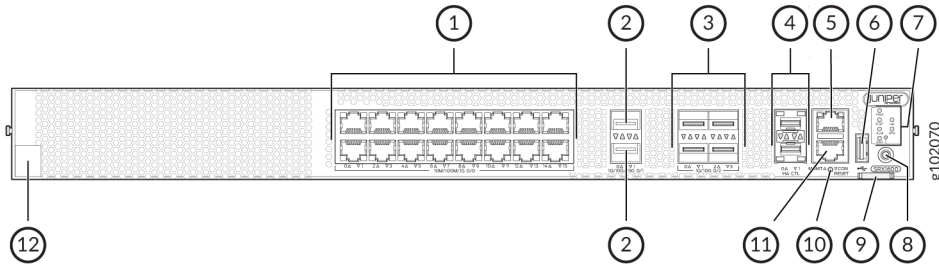

Table 5 on page 12 lists and describes the front panel components of the firewall.

Table 5: Components on the Front Panel of the SRX1600

Callout	Component (Label on the Chassis)	Description
1	Ethernet ports	Sixteen 10/100/1000 BASE-T ports (PIC 0 ports)
2	SFP28 ports	Two 1/10/25 GbE SFP28 MACsec ports for network traffic (PIC 1 ports)
3	SFP+ ports	Four 1/10 GbE SFP+ MACsec ports for network traffic (PIC 2 ports)
4	Chassis cluster ports (HA)	Two 1 GbE SFP chassis cluster control CTL ports with MACsec support
5	Management port (MGMT)	1 GbE RJ-45 port
6	USB port	One USB 3.0 Type A port that accepts a USB storage device

Table 5: Components on the Front Panel of the SRX1600 (Continued)

Callout	Component (Label on the Chassis)	Description
7	Chassis LEDs	Indicate component and system status and troubleshooting information at a glance.
8	Power button	Power button
9	Pull tab	Contains the CLEI code and serial number of the device
10	RESET	Reset button. To reset the system, press and hold the RESET button for around 250 ms.
11	Console port (CON)	You can connect a laptop to the SRX1600 to manage the CLI. The port uses an RJ-45 serial connection and supports the RS-232 (EIA-232) standard.
12	Claim code	You can use the QR code to claim and onboard your device to Juniper Security Director.



NOTE: The BASE-T PIC 0 ports (ge-0/0/0 to ge-0/0/15) support autonegotiation. The SFP28 PIC 1 ports (et-0/1/0 to et-0/1/1) do not support SFP-T or autonegotiation. The SFP+ PIC 2 ports (xe-0/2/0 to xe-0/2/3) support 1 GbE SFP-T but do not support autonegotiation.

Rear Panel of the SRX1600

Figure 2 on page 14 shows the rear panel of the AC variant of an SRX1600 firewall.

Figure 2: Rear Panel Components of the AC Variant of the SRX1600

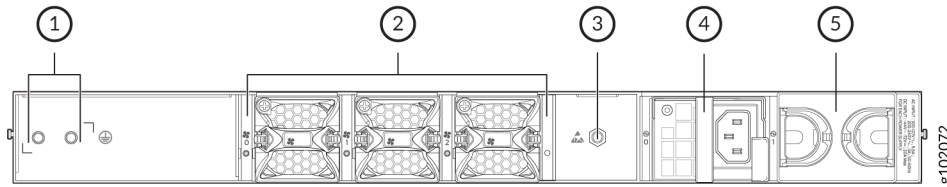

Table 6 on page 14 lists and describes the rear panel components of the AC variant of the SRX1600.

Table 6: Components on the Rear Panel of the AC Variant of the SRX1600 Firewall

Callout	Component	Description
1	Grounding point	Grounding point
2	Fan modules	Three airflow out (AFO) fan modules (2+1 redundancy). Two fan modules provide airflow across the internal components of the chassis. The third fan module provides redundancy.
3	ESD	ESD socket
4	PSU	The SRX1600 has a 450 W AC PSU.
5	Empty PSU slot	The SRX1600 has a blank slot to install an additional PSU (1+1 redundancy).



NOTE: We ship the SRX1600 with only one PSU. You can order the second PSU separately, if required.

You must not mix AC and DC power supplies in the same chassis.

Figure 3 on page 15 shows the rear panel of the DC variant of the SRX1600.

Figure 3: Rear Panel Components of the DC Variant of the SRX1600

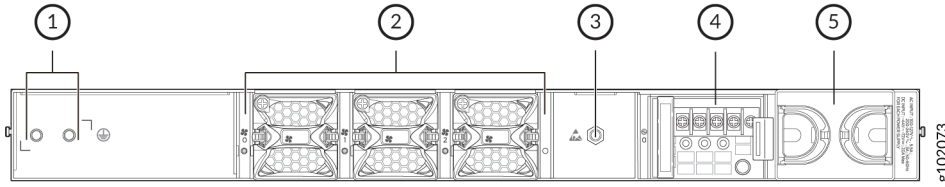

Table 7 on page 15 lists and describes the rear panel components of the DC variant of the SRX1600.

Table 7: Components on the Rear Panel of the DC Variant of the SRX1600 Firewall

Callout	Component	Description
1	Grounding point	Grounding point
2	Fan modules	Three airflow out (AFO) fan modules (2+1 redundancy). Two fan modules provide airflow across the internal components of the chassis. The third fan module provides redundancy.
3	ESD	ESD socket
4	PSU	The SRX1600 has a 450 W DC PSU.
5	Empty PSU slot	The SRX1600 has a blank slot to install an additional PSU (1+1 redundancy).

i **NOTE:** We ship the SRX1600 with only one PSU. You can order the second PSU separately, if required.
You must not mix AC and DC power supplies in the same chassis.

Chassis Status LEDs

Figure 4 on page 16 shows the LEDs on the front panel.

Figure 4: SRX1600 Front Panel Status LEDs

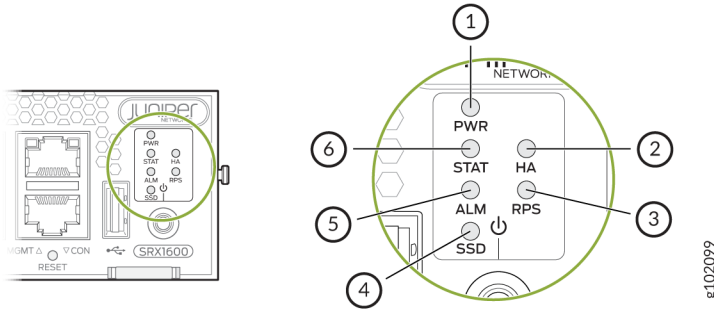

Table 8: SRX1600 Front Panel LEDs

Callout	LED	Description
1	PWR	<ul style="list-style-type: none"> • Solid green—The device is powered on. • Blinking green—The device is powered on. The device is in the bootup phase before OS initialization. • Red—The power supply has failed and must be replaced. • Off—The device is powered off.
2	HA	<ul style="list-style-type: none"> • Solid green—All HA links are available. • Red—Device is inoperable due to a monitor failure. • Off—HA is disabled.
3	RPS	<ul style="list-style-type: none"> • Solid green—The redundant power supply (RPS) is operating normally. • Solid red—The RPS is not operating normally. • Off—The RPS is not present on the device.

Table 8: SRX1600 Front Panel LEDs (*Continued*)

Callout	LED	Description
4	SSD	<ul style="list-style-type: none"> • Blinking green—The device is transferring data to or from the SSD storage device. • Solid red—Indicates an SSD storage device failure. • Off—SSD storage device is not present on the device.
5	ALM	<ul style="list-style-type: none"> • Solid red—Critical alarm • Solid amber—Non-critical alarm • Off—No alarms
6	STAT	<ul style="list-style-type: none"> • Solid green—The device is operating normally. • Solid red—Indicates a hardware component failure. • Off—The device is not receiving power.

Management Port LEDs

Figure 5 on page 18 shows the LEDs for the management ports.

Figure 5: SRX1600 Management Port LEDs

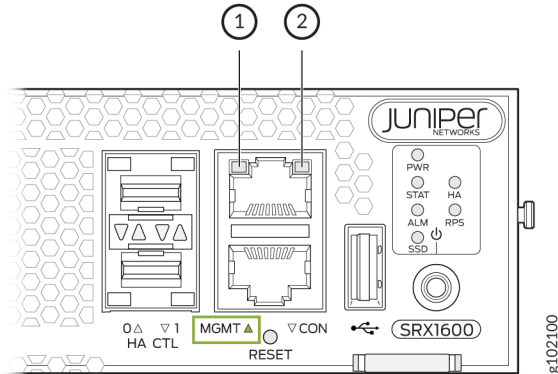

Table 9: Management Port LEDs

Callout	LED	Description
1	Link (LED on the left)	<ul style="list-style-type: none"> • Solid green—A link is established. • Off—No link established.
2	Activity (LED on the right)	<ul style="list-style-type: none"> • Blinking green—There is activity on the link. • Off—There is no link activity.

Network Port LEDs

The BASE-T and SFP ports have two LEDs to indicate the link activity and status. [Figure 6 on page 19](#) shows the location of the LEDs on the network ports and [Table 10 on page 19](#) describes the LEDs.

Figure 6: LEDs on the Network Ports

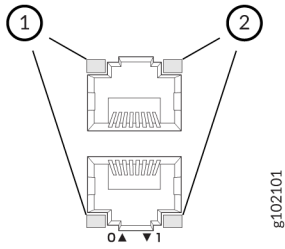

Table 10: LEDs on the Network Ports

Callout 1	Callout 2	Description (for RJ-45 ports)	Description (for SFP, SFP+, and SFP28 ports)
Status LED (Left LED)	Link and Activity LED (Right LED)		
Off	Off	Default (power on with or without Transceiver)	Default (power on with or without Transceiver)
Solid Green	Solid Green	1 Gbps link is up but there is no traffic on the port.	25 Gbps link is up but there is no traffic on the port.
	Blinking Green	1 Gbps link is up and there is traffic on the port.	25 Gbps link is up and there is traffic on the port.
Blinking Green	Solid Green	100 Mbps link is up but there is no traffic on the port.	10 Gbps link is up but there is no traffic on the port.
	Blinking Green	100 Mbps link is up and there is traffic on the port.	10 Gbps link is up and there is traffic on the port.
Off	Solid Green	10 Mbps link is up but there is no traffic on the port.	1 Gbps link is up but there is no traffic on the port.

Table 10: LEDs on the Network Ports (Continued)

Callout 1	Callout 2	Description (for RJ-45 ports)	Description (for SFP, SFP +, and SFP28 ports)
Status LED (Left LED)	Link and Activity LED (Right LED)		
	Blinking Green	10 Mbps link is up and there is traffic on the port.	1 Gbps link is up and there is traffic on the port.
Off	Off	This indicates one of the following events: <ul style="list-style-type: none"> The link is down or a fault has occurred. The port has been disabled by the administrator. 	This indicates one of the following events: <ul style="list-style-type: none"> The link is down or a fault has occurred. The port has been disabled by the administrator.

Figure 7 on page 20 shows the location of the LEDs on the HA ports and Table 11 on page 21 describes the LEDs.

Figure 7: LEDs on the HA Ports

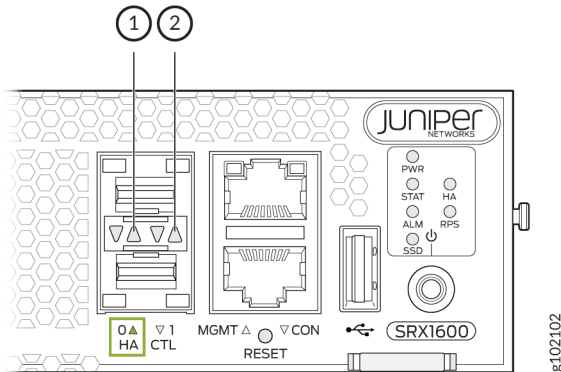

Table 11: HA Port LEDs

Callout	LED	Description
1	Link (LED on the left)	<ul style="list-style-type: none"> Blinking green—A link is established. Off—There is no link established.
2	Activity (LED on the right)	<ul style="list-style-type: none"> Blinking green—There is activity on the link. Off—There is no link activity.

Cooling System and Airflow in the SRX1600

IN THIS SECTION

- Fans | 21
- SRX1600 Fan Module LEDs | 23

The cooling system in the SRX1600 consists of three fans. In addition to the fans, an internal fan in each power supply unit (PSU) also cools the device components.

Fans

The fans in the SRX1600 are hot-insertable and hot-removable field-replaceable units (FRUs). You can install the fans in the fan module slots on the rear of the device.

Figure 8: SRX1600 Fan Module

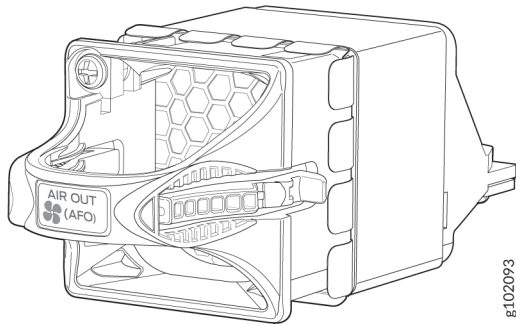
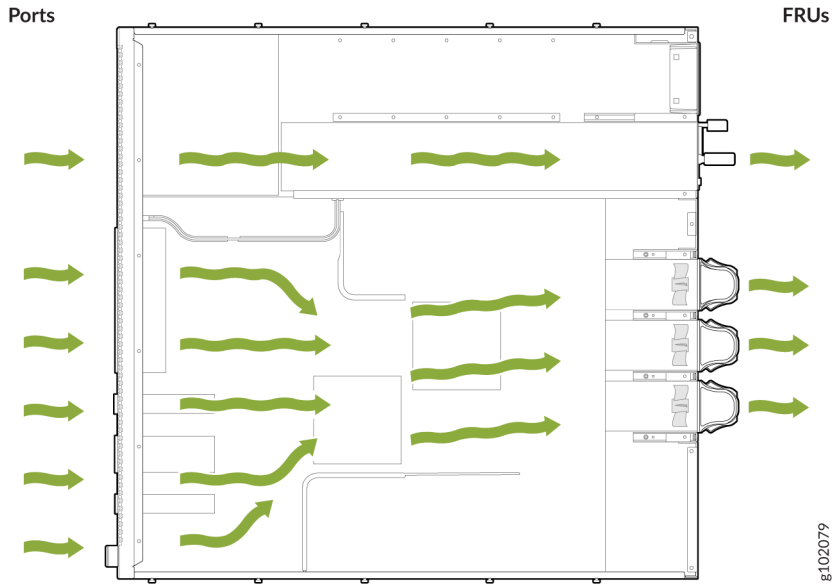

Table 12: Physical Specifications of the SRX1600 Fan Modules

Height	Width	Depth	Weight
1.61 in. (4.1 cm)	1.61 in. (4.1 cm)	4.41 in. (11.2 cm)	0.16 lb (74 g)

The SRX1600 firewalls provide front-to-back airflow. The fans modules pull the air toward them from the front of the chassis, and exhaust it through the back of the chassis.

Figure 9: Airflow Through the SRX1600 Chassis



SRX1600 Fan Module LEDs

You can examine the LEDs next to each fan module to check the status of the fans.

Figure 10: Fan Module LEDs

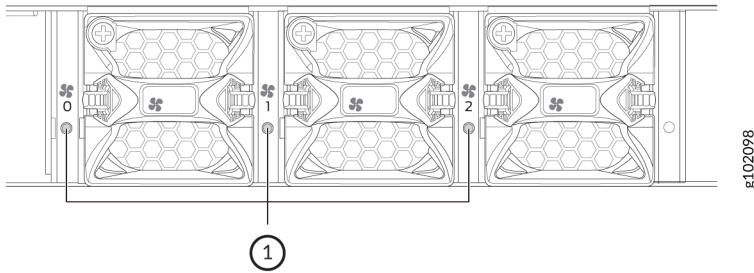

Table 13: Fan Module LEDs

LED Color	LED State	Description
Green	On steadily	The fan is operating normally. The system has verified that the module is engaged, that the airflow is in the correct direction, and that the fan is operating correctly.
Red	On steadily	The system has detected an error in the fan module. Replace the fan module immediately. Either the fan has failed, or it is seated incorrectly. To maintain proper airflow through the chassis, leave the fan module installed in the chassis until you are ready to replace it.

SRX1600 Power System

IN THIS SECTION

- [AC Power Supply for SRX1600 Firewalls | 25](#)
- [Supported AC Power Cords | 26](#)
- [DC Power Supply for SRX1600 Firewalls | 27](#)
- [PSU LEDs on SRX1600 Firewalls | 29](#)

The SRX1600 is powered by two power supplies for 1 + 1 redundancy. The SRX1600 has hot-removable and hot-insertable power supply units (PSUs). If one PSU fails, you can replace it without powering off or disrupting the device function. The second PSU balances the electrical load without interruption. A fan in each power supply provides cooling.



NOTE: We ship the SRX1600 with only one PSU. You can order the second PSU separately if required.

AC Power Supply for SRX1600 Firewalls

The following figure shows the AC PSU.

Figure 11: AC Power Supply Unit for SRX1600

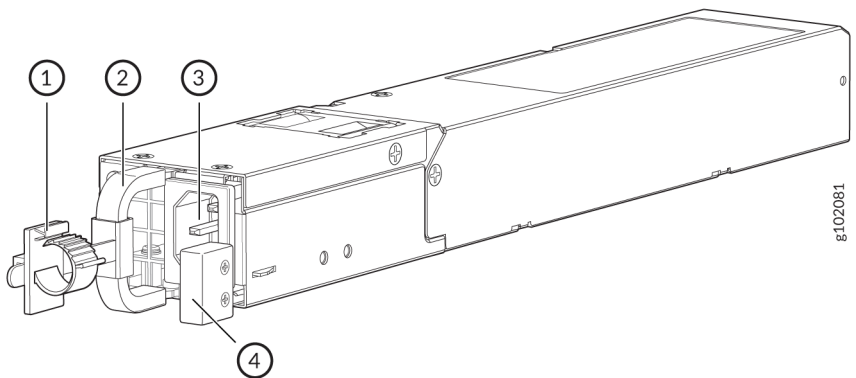

Table 14: AC Power Supply Unit for SRX1600

Callout	Name
1	Power cord retainer
2	PSU handle
3	AC power inlet
4	PSU latch

Table 15: Physical Specifications of the SRX1600 AC PSU

Height	Width	Depth (including handle)	Weight
1.61 in. (4.1 cm)	2.17 in. (5.5 cm)	14.17 in. (36 cm)	2.14 lb (970 g)

Table 16 on page 26 describes the AC power specifications for SRX1600.

Table 16: AC Power Specifications for SRX1600

Item	Specification
AC input voltage	Operating range: 100–127 VAC / 200–240 VAC
AC input line frequency	50–60 Hz
AC input current rating	5.5 A at 100–127 VAC 3 A at 200–240 VAC
Maximum power output	450 W

Table 17: AC Power Consumption for SRX1600

Item	Specification
Maximum power consumption	162 W
Average power consumption	137 W

You must use a dedicated external circuit breaker for each PSU. We recommend that you use a 10 A (250 VAC), or as permitted by the local code.

Supported AC Power Cords



WARNING: Use the AC power cord with the firewall only and not for any other purpose.



NOTE: In North America, AC power cords must not exceed a length of 4.5 m (approximately 14.75 ft). This length complies with National Electrical code (NEC) Section 400-8 (NFPA 75, 5-2.2) and 210-52, and Canadian Electrical Code (CEC) Section 4-010(3).

Table 16 on page 26 provides power cord specifications, and Figure 12 on page 27 depicts the plug on the AC power cord provided for each country or region.

Table 18: AC Power Cord Specifications

Country	Electrical Specification	Plug Standards
Australia	250 VAC, 10 A, 50 Hz	AS/NZ 3112-1993
China	250 VAC, 10 A, 50 Hz	GB2099.1 1996 and GB1002 1996 (CH1-10P)
Europe (except Italy and United Kingdom)	250 VAC, 10 A, 50 Hz	CEE (7) VII
Italy	250 VAC, 10 A, 50 Hz	CEI 23-16/VII
Japan	125 VAC, 12 A, 50 or 60 Hz	JIS 8303
North America	125 VAC, 10 A, 60 Hz	NEMA 5-15
United Kingdom	250 VAC, 10 A, 50 Hz	BS 1363A

Figure 12: AC Plug Types



NOTE: Power cords and cables must not block access to firewall components or drape where people might trip on the cables.

DC Power Supply for SRX1600 Firewalls

The following figure shows the DC PSU.

Figure 13: DC Power Supply Unit for SRX1600

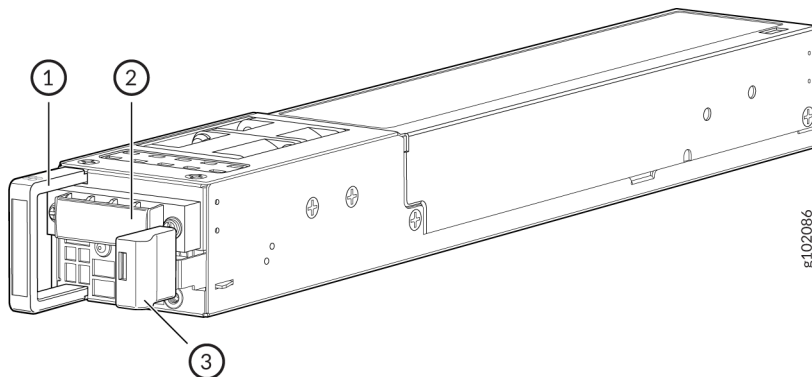

Table 19: DC Power Supply Unit for SRX1600

Callout	Name
1	PSU handle
2	DC power terminals
3	PSU latch

Table 20: Physical Specifications of the SRX1600 DC PSU

Height	Width	Depth	Weight
1.61 in. (4.1 cm)	2.17 in. (5.5 cm)	14.17 in. (36 cm) (including handle)	2.16 lb (980 g)

[DC Power Specifications for SRX1600 on page 26](#) describes the DC power specifications for SRX1600.

Table 21: DC Power Specifications for SRX1600

Item	Specification
DC Input Voltage	-44 VDC through -72 VDC
DC input current rating	20 A maximum

Table 21: DC Power Specifications for SRX1600 (Continued)

Item	Specification
Maximum power output	650 W

Table 22: DC Power Consumption for SRX1600

Item	Specification
Maximum power consumption	161 W
Average power consumption	132 W

PSU LEDs on SRX1600 Firewalls

The AC PSU has a single bicolor LED that indicates the status. [Figure 14 on page 29](#) shows the location of the LED on the AC PSU and [Table 23 on page 29](#) describes it.

Figure 14: LEDs on the AC PSU

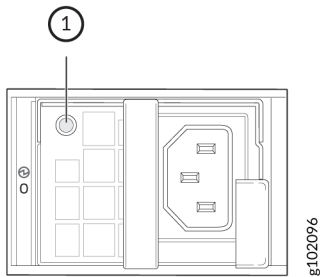

Table 23: LEDs on the AC PSU

Callout	Color	State	Description
1	Unlit	Off	No power input.
	Green	On	PSU is operating normally.

Table 23: LEDs on the AC PSU (Continued)

Callout	Color	State	Description
	Amber	Blinking	The device is in standby mode.
		Blinking	PSU is operating under overload.
		On	The system has detected an error in the PSU. Replace the PSU immediately. To maintain proper airflow through the chassis, leave the PSU installed in the chassis until you are ready to replace it.

Figure 15 on page 30 shows the location of the LEDs on the DC PSU and Table 24 on page 30 describes the LEDs.

Figure 15: LEDs on the DC PSU

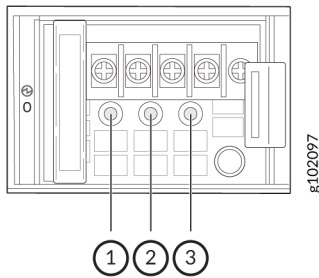

Table 24: LEDs on the DC PSU

Callout	Name	Color	State	Description
1	Input	Unlit	Off	No power input.
		Green	On	The PSU is operating normally.
2	Output	Unlit	Off	No power output.
		Green	On	The PSU is operating normally.

Table 24: LEDs on the DC PSU (Continued)

Callout	Name	Color	State	Description
3	Fault	Amber	On	The system has detected an error in the PSU. Replace the PSU immediately. To maintain proper airflow through the chassis, leave the PSU installed in the chassis until you are ready to replace it.

3

CHAPTER

Site Planning, Preparation, and Specifications

IN THIS CHAPTER

- Site Preparation Checklist for SRX1600 | 33
 - SRX1600 Site Guidelines and Requirements | 34
 - Cable Specifications and Pinouts for SRX1600 | 40
-

Site Preparation Checklist for SRX1600

The checklist in [Table 25 on page 33](#) summarizes the tasks you need to perform when preparing a site to install the SRX1600 .

Table 25: Site Preparation Checklist to install the SRX1600

Item or Task	Additional Information
Environment	
Verify that environmental factors such as temperature and humidity do not exceed device tolerance levels.	"Environmental Requirements and Specifications for SRX1600" on page 36
Power	
Measure the distance between the external power sources and the device installation site.	
Locate sites for connection of system grounding.	
Calculate the power consumption and requirements.	
Rack Requirements	
Verify that your rack meets the minimum requirements.	"Rack Requirements for the SRX1600" on page 38
Rack Installation	

Table 25: Site Preparation Checklist to install the SRX1600 (Continued)

Item or Task	Additional Information
Plan the rack location, including required space clearances.	
Secure the rack to the floor and building structure.	
Cables	
<ul style="list-style-type: none"> • Acquire cables and connectors. • Review the maximum distance allowed for each cable. Choose the length of cable based on the distance between the hardware components being connected. • Plan the cable routing and management. 	

SRX1600 Site Guidelines and Requirements

IN THIS SECTION

- [General Site Installation Guidelines | 35](#)
- [Site Electrical Wiring Guidelines | 35](#)
- [Environmental Requirements and Specifications for SRX1600 | 36](#)
- [Clearance Requirements for Hardware Maintenance of the SRX1600 | 37](#)

General Site Installation Guidelines

Take the following precautions to plan an acceptable operating environment for your SRX1600 and prevent equipment failures caused due to environment:

- Keep the area around the chassis free from dust.
- Follow the prescribed airflow guidelines to ensure that the cooling system functions properly and that exhaust from other equipment does not blow into the intake vents of the device.
- Follow the electrostatic discharge (ESD) procedures to prevent equipment damage. Static discharge can cause components to fail completely or intermittently over time.
- Install the device in a secure area so that only authorized personnel can access the device.

Site Electrical Wiring Guidelines

[Table 26 on page 36](#) describes the factors you must consider while planning the electrical wiring at your site.



WARNING: You must provide a properly grounded and shielded environment and use electrical surge-suppression devices.

Table 26: Site Electrical Wiring Guidelines

Site Wiring Factor	Guidelines
Signaling limitations	<p>If your site experiences any of the following problems, consult experts in electrical surge suppression and shielding:</p> <ul style="list-style-type: none"> • Improperly installed wires cause radio frequency interference (RFI). • Damage from lightning strikes occurs when wires exceed recommended distances or pass between buildings. • Electromagnetic pulses (EMPs) caused by lightning can damage unshielded conductors and electronic devices.
Radio frequency interference	<p>To reduce or eliminate RFI from your site wiring, you can:</p> <ul style="list-style-type: none"> • Use a twisted-pair cable with a good distribution of grounding conductors. • If you must exceed the recommended distances, use a high-quality twisted-pair cable with one ground conductor for each data signal when applicable.
Electromagnetic compatibility	<p>If your site is susceptible to problems with electromagnetic compatibility (EMC), particularly from lightning or radio transmitters, seek expert advice.</p> <p>Strong sources of electromagnetic interference (EMI) may cause the following problems:</p> <ul style="list-style-type: none"> • Destruction of the signal drivers and receivers in the device • Equipment damage due to power surge in electrical lines

Environmental Requirements and Specifications for SRX1600

The SRX1600 must be housed in dry, clean, well-ventilated, and temperature-controlled environment. Follow these environmental guidelines:

- Ensure that the site is dust free because dust can clog air intake vent. This reduces the efficiency of the cooling system.

- Maintain ambient airflow for normal operation. If the airflow is blocked or restricted, or if the intake air is too warm, the device might overheat.

The following table lists the environmental specifications for the SRX1600:

Table 27: Environmental Specifications for SRX1600

Description	Value
Operating temperature	0 °C to 40 °C (32 °F to 104 °F)
Storage temperature	-40 °C to 70 °C (-40 °F to 158 °F)
Relative humidity	Normal operation ensured in relative humidity range of 5% through 90%, non-condensing
Altitude	6000 ft.

Clearance Requirements for Hardware Maintenance of the SRX1600

When planning the site for installing the SRX1600, ensure that there is sufficient space around the installed chassis.

- For the operating temperature of the SRX1600 to be optimal, the airflow around the chassis must be unrestricted.
- For service personnel to remove and to install hardware components, and to accommodate the interface and power cable bend radius, there must be adequate space at the front and rear of the appliance. Allow at least 24 in. (61 cm) of space both at the front and the rear of the appliance.
- If you are mounting the appliance in a rack with other equipment, or if you are placing it on the desktop near other equipment, ensure that the exhaust from other equipment does not blow into the intake vents of the chassis.

Figure 16: Clearance Requirements for Hardware Maintenance of SRX1600

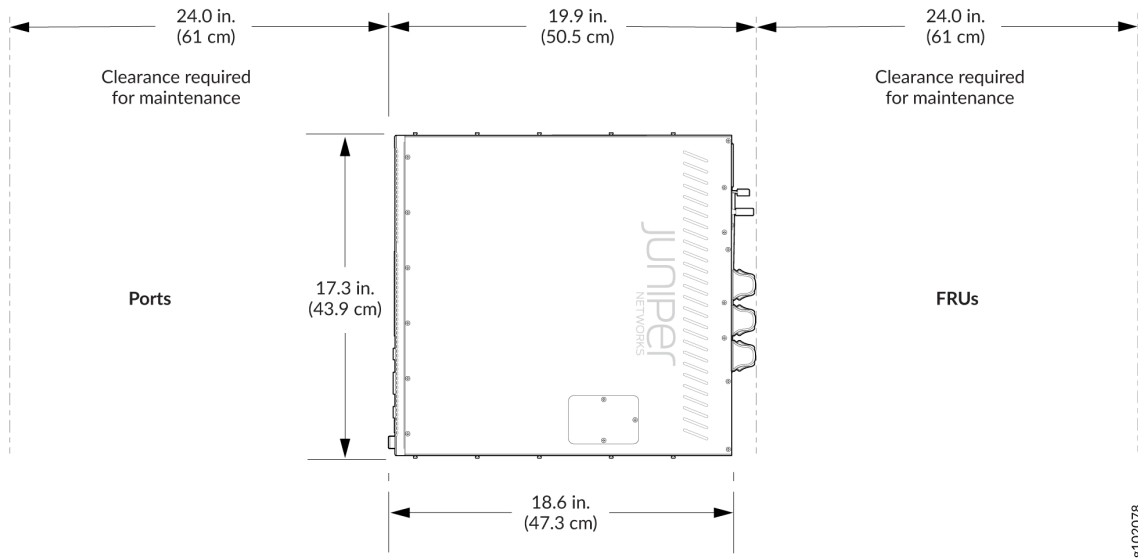

Rack Requirements for the SRX1600

You can mount the SRX1600 on four-post racks. The rack mounting kit is shipped with the device. [Table 28 on page 38](#) provides the rack requirements and specifications for SRX1600.

Table 28: Rack Requirements and Specifications

Rack Requirement	Guidelines
Rack type	<p>Use a four-post rack with bracket holes or hole patterns spaced at 1 U increments (1.75 in. or 4.45 cm). Ensure that the rack meets the size and strength requirements to support the weight.</p> <p>A U is the standard rack unit as defined in Cabinets, Racks, Panels, and Associated Equipment (document number EIA-310-D) published by the Electronics Industry Association.</p>

Table 28: Rack Requirements and Specifications (Continued)

Rack Requirement	Guidelines
Mounting bracket hole spacing	<p>Ensure that the holes in the mounting brackets are spaced at 1 U (1.75 in. or 4.45 cm) so that the device can be mounted in any rack that provides holes that are spaced at that distance.</p> <p>The front rack opening between the flanges must be 450 mm wide + 2 mm (17.75 in. + 0.08 in.).</p>
Rack size and strength	<ul style="list-style-type: none"> • Ensure that the rack complies with the standards for a 19 in. rack as defined in Cabinets, Racks, Panels, and Associated Equipment (document number EIA-310-D) published by the Electronics Industry Association. • Use an 800 mm rack as defined in the four-part Equipment Engineering (EE) European telecommunications standard for equipment practice (document numbers ETS 300 119-1 through 119-4) published by the European Telecommunications Standards Institute (http://www.etsi.org). <p>The horizontal spacing between the rails in a rack compliant with this standard is usually wider than the device's mounting brackets. The mounting brackets measure 19 in. (48.26 cm) from outer edge to outer edge. Use approved wing devices to narrow the opening between the rails as required.</p> <ul style="list-style-type: none"> • Ensure that the rack rails are spaced widely enough to accommodate the external dimensions of the device chassis. The outer edges of the front-mounting brackets extend the width to 19 in. (48.26 cm). • Ensure that for four-post installations, the front and rear rack rails are spaced between 23.6 in. (60 cm) and 36 in. (91.4 cm) front-to-back. • Ensure that the rack is strong enough to support the weight of the device. A fully-configured SRX1600 with 2 PSUs weighs about 17.86 lb (8.1 kg). • Ensure that the spacing of rails and adjacent racks allows for proper clearance around the device and rack.
Rack connection to building structure	<ul style="list-style-type: none"> • Secure the rack to the building structure. • If earthquakes occur in your geographical area, secure the rack to the floor. • Secure the rack to the ceiling brackets and to wall or floor brackets for maximum stability.

Cable Specifications and Pinouts for SRX1600

IN THIS SECTION

- [Transceiver Support for SRX1600 | 40](#)
- [RJ-45 Connector Pinouts for the SRX1600 Firewall Management Port | 40](#)
- [RJ-45 Connector Pinouts for the SRX1600 Firewall Console Port | 41](#)

Transceiver Support for SRX1600

Use the Hardware Compatibility Tool to find information about the pluggable transceivers and the supported connector types of your Juniper Networks device. The tool also documents the optical and cable characteristics, where applicable, for each transceiver. You can search for transceivers by product, and the tool displays all the transceivers supported on that device. You can also search by category, interface speed, or type. The list of supported transceivers for the SRX1600 is located at <https://apps.juniper.net/hct/product/>.



CAUTION: If you face a problem running a Juniper Networks device that uses a third-party optic or cable, the Juniper Networks Technical Assistance Center (JTAC) can help you diagnose the source of the problem. Your JTAC engineer might recommend that you check the third-party optic or cable and potentially replace it with an equivalent Juniper Networks optic or cable that is qualified for the device.



CAUTION: To maintain agency approvals, use only a properly constructed, shielded cable.

RJ-45 Connector Pinouts for the SRX1600 Firewall Management Port

The port on the front panel labeled MGMT is a 10/100/1000-Mbps Ethernet RJ-45 port that accepts an Ethernet cable for connecting the services gateway to a management LAN (or other device that supports out-of-band management). [Table 29 on page 41](#) describes the RJ-45 connector pinouts for the Ethernet port.

Table 29: RJ-45 Connector Pinouts for SRX1600 Firewall Management Port

Pin	Signal
1	TX+
2	TX-
3	RX+
4	Termination network
5	Termination network
6	RX-
7	Termination network
8	Termination network

RJ-45 Connector Pinouts for the SRX1600 Firewall Console Port

The port on the front panel labeled CON is an asynchronous serial interface that accepts an RJ-45 connector. [Table 30 on page 41](#) describes the RJ-45 connector pinouts for the console port.

Table 30: RJ-45 Connector Pinouts for the SRX1600 Firewall Console Port

Pin	Signal	Description
1	RTS	Request to Send
2	DTR	Data Terminal Ready

Table 30: RJ-45 Connector Pinouts for the SRX1600 Firewall Console Port (Continued)

Pin	Signal	Description
3	TXD	Transmit Data
4	Ground	Signal Ground
5	Ground	Signal Ground
6	RXD	Receive Data
7	DSR/DCD	Data Set Ready
8	CTS	Clear to Send

4

CHAPTER

Initial Installation and Configuration

IN THIS CHAPTER

- [SRX1600 Installation Overview | 44](#)
 - [Unpack the SRX1600 | 44](#)
 - [Install the SRX1600 in a Rack | 46](#)
 - [Connect the SRX1600 to Power | 56](#)
 - [Connect the SRX1600 to External Devices | 63](#)
 - [Register Products—Mandatory to Validate SLAs | 65](#)
 - [Configure Junos OS on the SRX1600 | 66](#)
-

SRX1600 Installation Overview

To install and configure the SRX1600 :

1. Follow instructions in "[Unpack the SRX1600](#)" on page 44.
2. Install the firewall as described in "[Install the SRX1600 in a Rack](#)" on page 46.
3. Connect cables to external devices as described in "[Connect the SRX1600 to External Devices](#)" on page 63.
4. Connect the grounding cable and power supplies as described in "[Connect the SRX1600 to Power](#)" on page 56. Power on the device.
5. Perform initial configuration by following the instructions in "[Configure Junos OS on the SRX1600](#)" on page 66.

RELATED DOCUMENTATION

| [SRX1600 Site Guidelines and Requirements](#) | 34

Unpack the SRX1600

SUMMARY

Unpack the appliance with the recommended tools and follow the recommended procedure.

IN THIS SECTION

- [Tools and Parts Required to Unpack the SRX1600](#) | 44
- [Unpack an SRX1600](#) | 45
- [Verify Parts Received with the SRX1600](#) | 45

Tools and Parts Required to Unpack the SRX1600

To unpack the device and prepare for installation, you need the following tools:

- Phillips (+) screwdriver, number 2
- A box cutter or packing knife to slice open the tape that seals the boxes

Unpack an SRX1600

We ship the SRX1600 in a cardboard carton and secure it with foam packing material.



NOTE: The SRX1600 has maximum protection inside the cardboard carton. Do not unpack it until you are ready to begin installation.

To unpack the SRX1600:

1. Move the cardboard carton to a staging area as close to the installation site as possible. Make sure that you have enough room to remove the components from the chassis.
2. Position the cardboard carton with the arrows pointing up.
3. Carefully open the top of the cardboard carton.
4. Remove the foam covering the top of the SRX1600.
5. Verify the parts received against the list in [Table 31 on page 46](#).
6. Store the brackets and bolts inside the accessory box.
7. Save the shipping carton and packing materials in case you need to move or ship the appliance at a later time.

Verify Parts Received with the SRX1600

The shipment includes a packing list. Check the parts you receive in the shipping carton against the items on the packing list. We ship the parts as per the configuration that you order.

If any part on the packing list is missing, contact your customer service representative or contact Juniper customer care from within the U.S. or Canada by telephone at 1-888-314-5822. For international-dial or direct-dial options in countries without toll-free numbers, see <https://www.juniper.net/support/requesting-support.html>.

Table 31: Parts List for the SRX1600

Component	Quantity
SRX1600 Chassis Part number: SRX1600-CHAS	1
Power supply unit	1 AC
Fan	3
AC power cord that is appropriate for your geographical location	1 (only for AC models)
Rack mount kit	1
Documentation Roadmap	1



NOTE: We ship the SRX1600 with only one power supply unit (PSU). You can order the second PSU separately, if required.

Install the SRX1600 in a Rack

SUMMARY

Mount the SRX1600 on a rack by following the recommended procedures that are appropriate for your site.

IN THIS SECTION

- Mount your Device by Using the JNP-4P-TL-1RU-RMK Rack Mount Kit on a Square Hole 4-Post Rack | [47](#)
- Mount your Device by Using the JNP-4P-TL-1RU-RMK Rack Mount Kit on a Threaded-Hole 4-Post Rack | [50](#)

You can mount the SRX1600 on a four-post rack or in a cabinet. Use the toolless rack mount kit shipped with the device.

Complete the following prerequisites before you mount the device:

- Prepare the site for installation as described in "[SRX1600 Site Guidelines and Requirements](#)" on page 34.
- Ensure that the site has adequate clearance for both airflow and hardware maintenance, as described in "[SRX1600 Site Guidelines and Requirements](#)" on page 34.
- Unpack the device as described in "[Unpack the SRX1600](#)" on page 44.



NOTE: Ensure that you support the rear of the chassis throughout the process of mounting the appliance on the rack.



CAUTION: A qualified technician must verify that the rack or cabinet is strong enough to support the device's weight before mounting the device. Have the technician verify also that the rack or cabinet has adequate support at the installation site.



CAUTION: If you are installing more than one device on a rack or in a cabinet, install the first device at the bottom of the rack.

Mount your Device by Using the JNP-4P-TL-1RU-RMK Rack Mount Kit on a Square Hole 4-Post Rack

Ensure that you have the following tools and parts available:

- An ESD grounding strap—not provided.
- A pair of side mounting brackets that attach to the chassis—provided with the rack mount kit.
- A pair of front and rear mounting rails that attach to the rack posts—provided with the rack mount kit.

To mount the device on a four-post rack:

1. Review the [General Safety Guidelines and Warnings](#).
2. Wrap and fasten one end of the electrostatic discharge (ESD) cable grounding strap around your bare wrist, and connect the other end to a site ESD point.

3. To attach the side mounting brackets to the chassis, align the keyholes on the mounting brackets over the shoulder screws on the chassis. Slide the mounting brackets toward the rear of the chassis.

Figure 17: Attach the Side Mounting Brackets

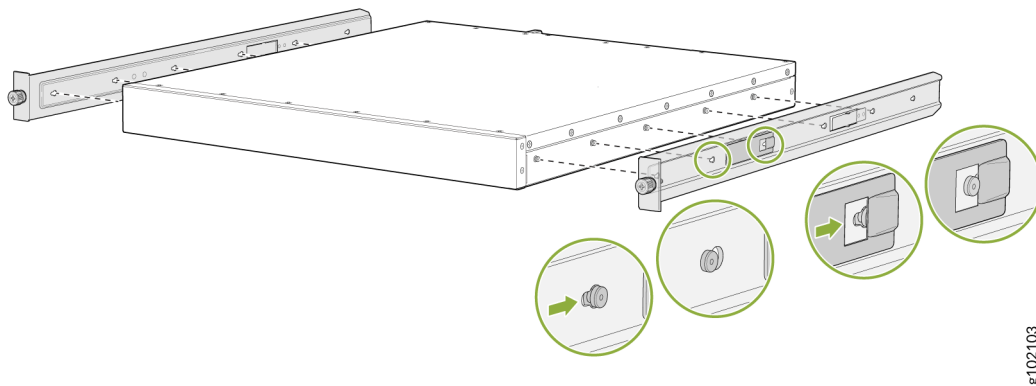

4. Assemble the mounting rails by sliding the rear floating rails into the front rails.

Figure 18: Assemble the Mounting Rails

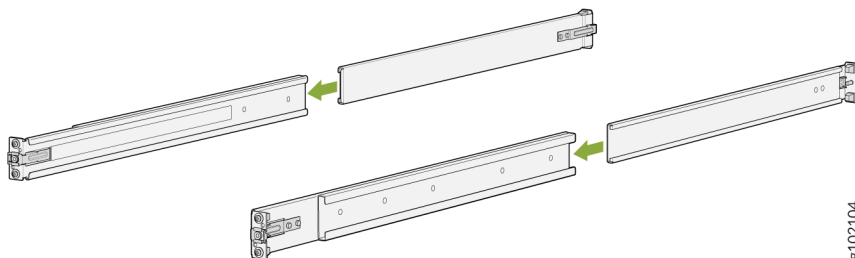

5. Install the mounting rails on the rack:
 - a. Align the guide blocks of the rear mounting rails with the rear-post holes. Pull the rear mounting rails toward the front of the rack to lock the rails in place. You will hear a distinct click sound when the latch locks into the corresponding rack holes.

Figure 19: Install the Rear Mounting Rails

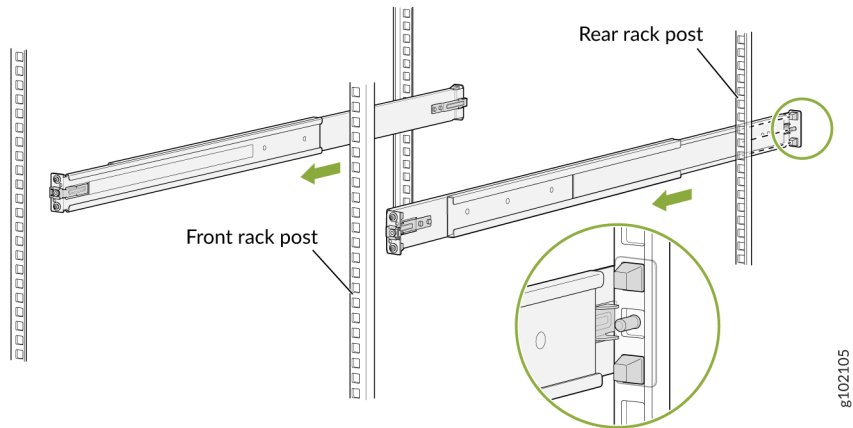

- b. Align the guide blocks of the front mounting rails with the front-post holes. Push the front mounting rails toward the rear of the rack to lock the rails in place. You will hear a distinct click sound when the latch locks into the corresponding rack holes.

Figure 20: Install the Front Mounting Rails

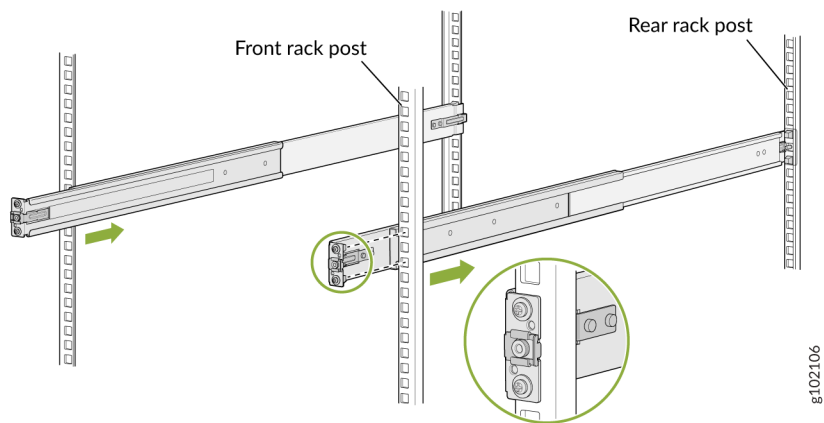

- c. Visually ensure that the front and rear latches are locked into place on the mounting rails. The mounting rails should be securely installed on the rack.
6. Lift the device and position it in the rack, aligning the side mounting-brackets with the mounting rails. Slide the device into the channels of the rack mounting rails.

Figure 21: Slide the Device into the Rack

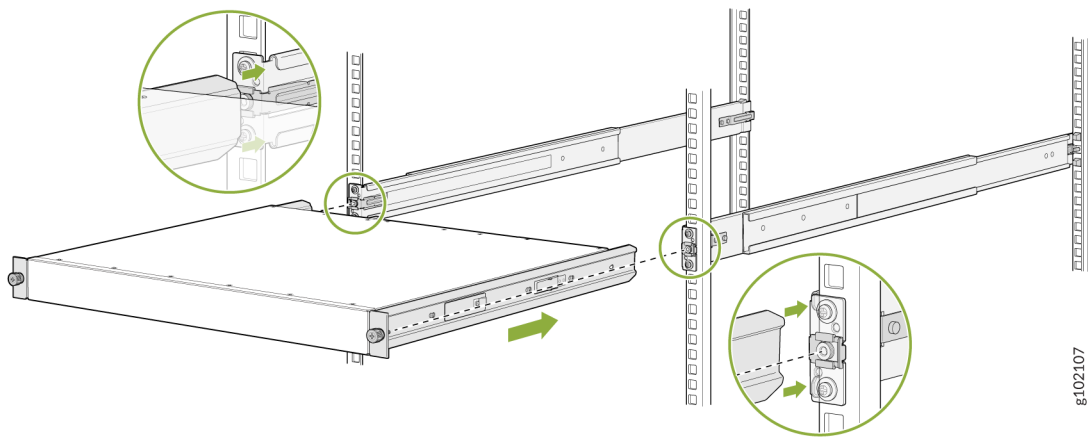

g102107

7. Tighten the two thumbscrews to secure the device.

Figure 22: Tighten the Thumbscrews

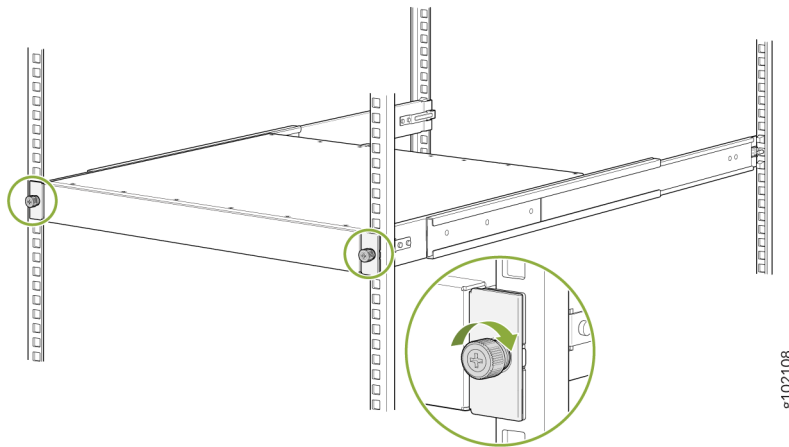

g102108

Mount your Device by Using the JNP-4P-TL-1RU-RMK Rack Mount Kit on a Threaded-Hole 4-Post Rack

Ensure that you have the following tools and parts available:

- An ESD grounding strap—not provided.
- A Number 2 Phillips (+) screwdriver—not provided.

- Eight screws to attach the mounting rails to the rack posts—not provided.
- A pair of side mounting brackets that attach to the chassis—provided with the rack mount kit.
- A pair of mounting front and rear rails that attach to the rack posts—provided with the rack mount kit.

To mount the device on a four-post rack with threaded holes:

1. Review the [General Safety Guidelines and Warnings](#).
2. Wrap and fasten one end of the electrostatic discharge (ESD) cable grounding strap around your bare wrist, and connect the other end to a site ESD point.
3. To attach the side mounting brackets to the chassis, align the keyholes on the mounting brackets over the shoulder screws on the chassis. Slide the mounting brackets toward the rear of the chassis.

Figure 23: Attach the Side Mounting Brackets

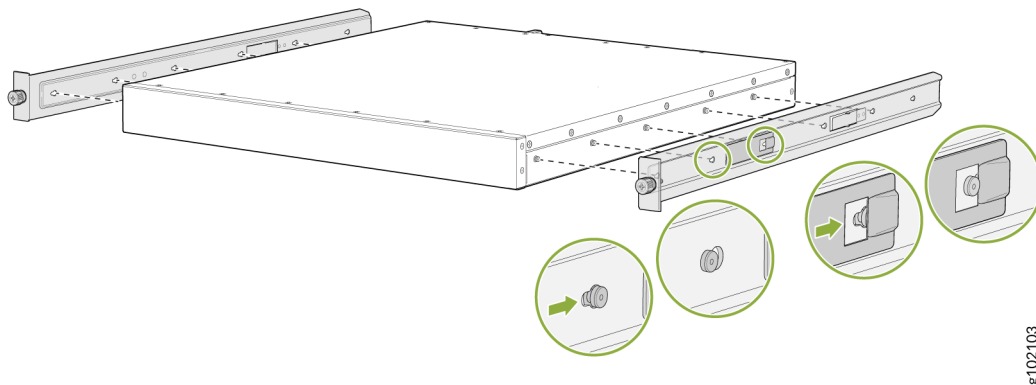

4. Assemble the mounting rails:
 - a. Remove the guide blocks from the front mounting rails by loosening the screws and washers.

Figure 24: Removing the Guide Blocks from the Front Mounting Rail

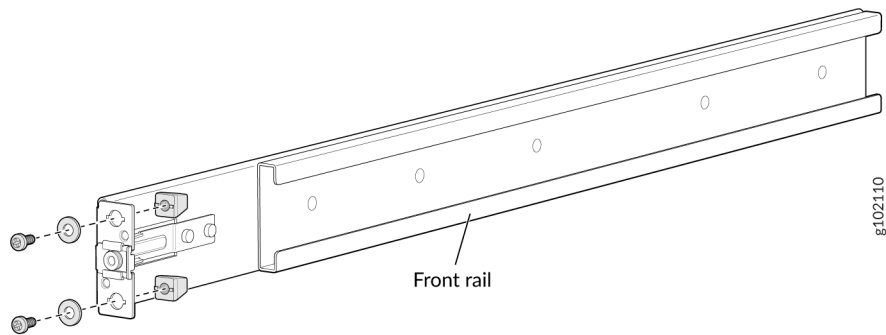

- b. Remove the guide blocks from the rear mounting rail by loosening the screws and washers.

Figure 25: Removing the Guide Blocks from the Rear Mounting Rail

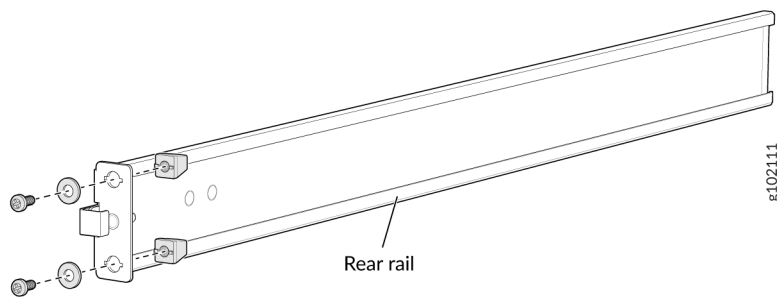

- c. Slide the rear floating rails into the front rails.

Figure 26: Assemble the Mounting Rails

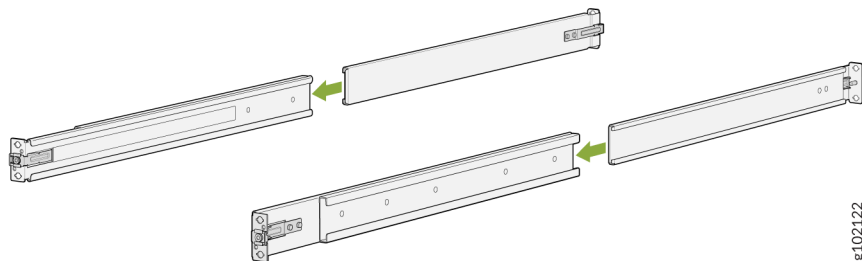

5. Install the mounting rails on the rack:

- a. Insert the guide pin of the rear mounting rails into the rear-post holes. Pull the rear mounting rails toward the front of the rack to lock the rails in place. You will hear a distinct click sound when the latch locks into place.

Figure 27: Install the Rear Mounting Rails

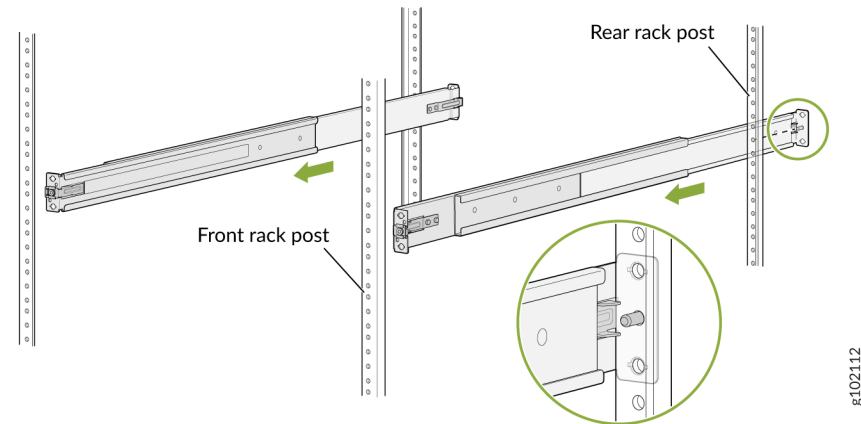

- b. Insert the guide pin of the front mounting rails into the front-post holes. Push the front mounting rails toward the rear of the rack to lock the rails in place. You will hear a distinct click sound when the latch locks into place. Secure the front mounting rails to the front rack post by using screws appropriate for your rack threaded size (not provided).

Figure 28: Install and Secure the Front Mounting Rails

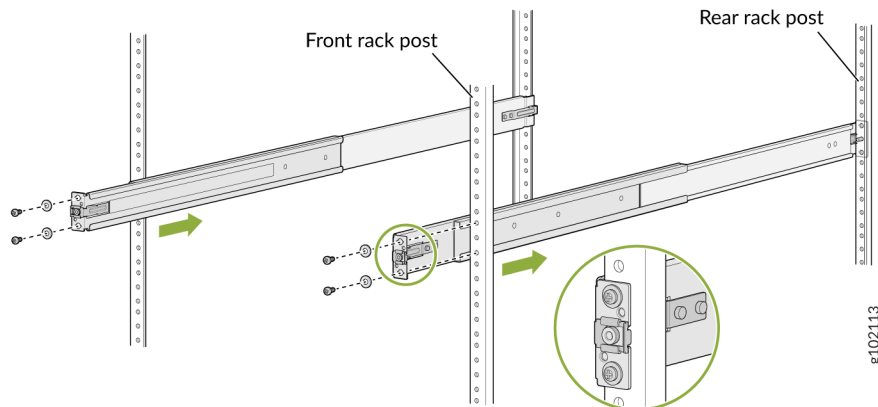

- c. Secure the rear mounting rails to the rear rack post by using screws appropriate for your rack threaded size (not provided).

Figure 29: Secure the Rear Mounting Brackets

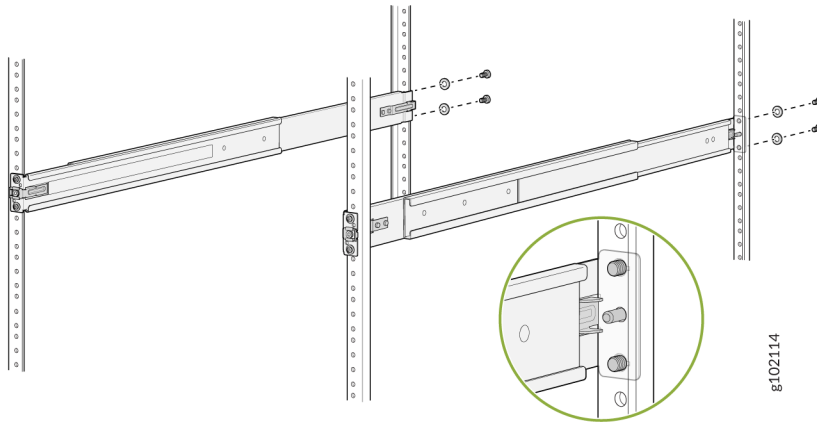

- d. Visually ensure that the front and rear latches are locked into place on the mounting rails. The mounting rails should be securely installed on the rack.

Figure 30: Mounting Rails Installed and Secured

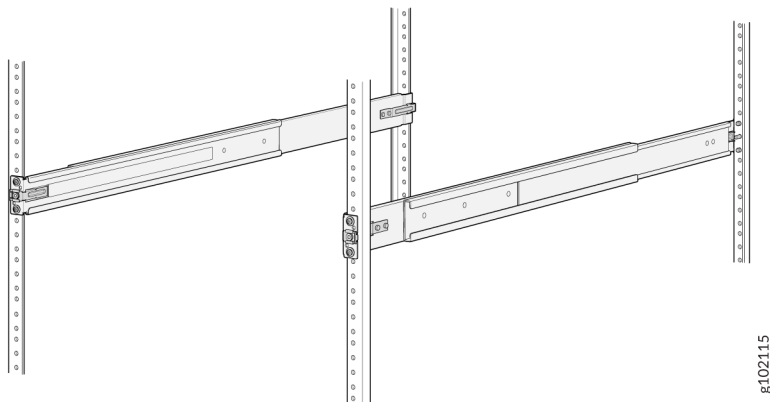

6. Lift the device and position it in the rack, aligning the side mounting brackets with the mounting rails. Slide the device into the channels of the rack mounting rails.

Figure 31: Slide the Device into the Rack

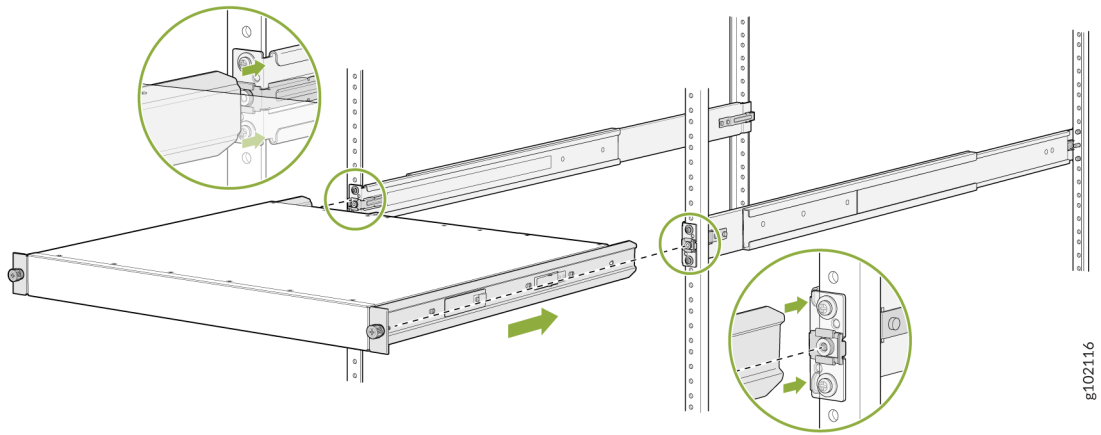

7. Tighten the two thumbscrews to secure the device.

Figure 32: Tighten the Thumbscrews

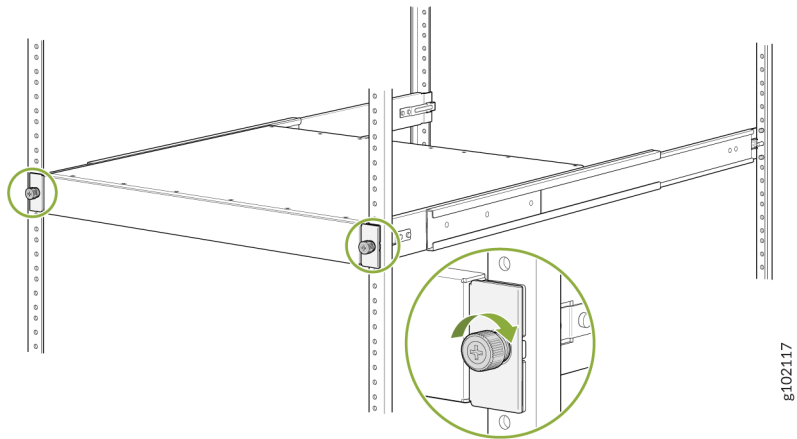

Connect the SRX1600 to Power

SUMMARY

Connecting power to the SRX1600 involves numerous steps and safety precautions to prevent equipment damage and personal injury.

IN THIS SECTION

- [Connect Earth Ground to the SRX1600 | 56](#)
- [Connect AC Power to the SRX1600 | 58](#)
- [Connect DC Power to the SRX1600 | 60](#)
- [Power Off the SRX1600 | 62](#)



NOTE: To meet the safety and electromagnetic interference (EMI) requirements and to ensure proper operation, you must connect the SRX1600 to an earth ground before you connect it to power.

Connect Earth Ground to the SRX1600



NOTE: Before you connect an earth ground to the protective earthing terminal of the SRX1600, ensure that a licensed electrician attaches an appropriate grounding terminal to the grounding cable you supply. Using a grounding cable with an incorrectly attached terminal can damage the device.

Before connecting the device to an earth ground, ensure that you have the following parts and tools:

- An electrostatic discharge (ESD) grounding strap.
- 2-hole protective earthing terminal.
- Grounding cable for your device—The grounding cable must be 6 AWG (4.11 mm²) stranded wire and rated 90 °C or per local electrical code.
- Grounding 2-hole terminal for your grounding cable—This attaches to the chassis grounding point located on the rear of the device.
- A Phillips screwdriver to tighten the screw.

The Panduit LCD6-14A-L terminals, or equivalent are sized for 6 AWG (4.11 mm²) cables. The 6 AWG (4.11 mm²) stranded wire should be rated 90 °C or per local electrical code. We recommend that you install heat-shrink tubing insulation around the crimped section of the power cables and lugs.

To ground the SRX1600, connect a grounding cable to earth ground. Attach the grounding cable to the chassis grounding point located on the rear of the device. Under all circumstances, use this grounding connection to ground the chassis.

To ground the device:

1. Wrap and fasten one end of the ESD grounding strap around your wrist and connect the other end to the ESD point on the chassis.
2. Ensure that all grounding surfaces are clean and brought to a bright finish before making the grounding connections.
3. Connect the grounding cable to a proper earth ground, such as the rack in which you mount the device.
4. Using a Phillips screwdriver, remove the two M5 screws from the grounding point on the rear of the chassis.

Figure 33: Grounding Point on the SRX1600

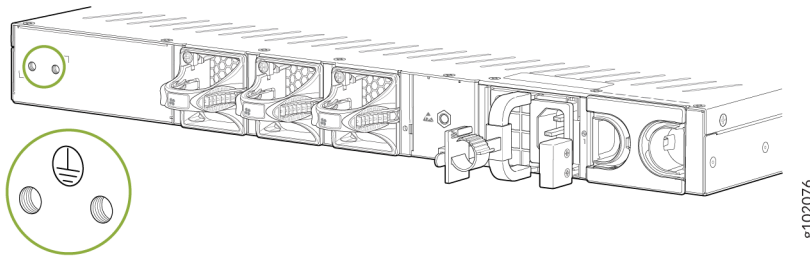

5. Place the grounding cable terminal attached to the grounding cable over the grounding point.
6. Secure the grounding cable terminal to the grounding point with the M5 screws removed earlier.

Figure 34: Connect the Grounding Cable to the SRX1600

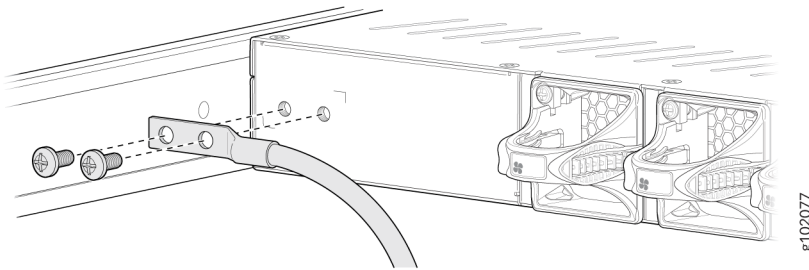

7. Verify that the grounding cable does not touch or block access to the device components. Make sure that it does not trail across the floor where people could trip over it.



NOTE: Ensure that the device is permanently connected to ground during operation.

Connect AC Power to the SRX1600

The AC power supply units (PSUs) in an SRX1600 are hot-removable and hot-insertable field-replaceable units (FRUs). You can remove and replace the PSUs without powering off the device or disrupting its functions.



CAUTION: You must not mix AC and DC power supplies in the same chassis.

Before you begin to connect AC power to the device:

- Ensure that you have connected the chassis to an earth ground.



CAUTION: Before you connect power to the device, a licensed electrician must attach a cable terminal to the grounding and power cables that you supply. A cable with an incorrectly attached terminal can damage the device (for example, by causing a short circuit).

To meet the safety and EMI requirements and to ensure proper operation, you must connect the chassis to an earth ground before you connect it to power. For installations that require a separate grounding conductor to the chassis, use the protective earthing terminal on the device chassis to connect to the earth ground. The device gains

additional grounding when you plug the PSU in the router to a grounded AC power outlet. Use the AC power cord appropriate for your geographical location.

- Ensure that you have a power cord appropriate for your geographical location available to connect AC power to the device.
- Read [AC Power Electrical Safety Guidelines](#) and [Action to Take After an Electrical Accident](#).
- Ensure that you have taken the necessary precautions to prevent electrostatic discharge (ESD) damage.
- Ensure that you have an ESD grounding strap.
- If not already installed, install the power supplies in the device.

To connect AC power to an SRX1600:

1. Wrap and fasten one end of the ESD wrist strap around your bare wrist, and connect the other end of the strap to the ESD point on the device.
2. Ensure that you fully insert the power supplies into the chassis.
3. Locate the AC power cords shipped with the SRX1600; the cords have plugs appropriate for your geographical location. See [Table 18 on page 27](#).
4. Insert the coupler end of the power cord into the AC power cord inlet on the AC power supply faceplate.
5. Push the power cord retainer onto the power cord (see [Figure 35 on page 59](#)).

Figure 35: Connect AC Power Cord

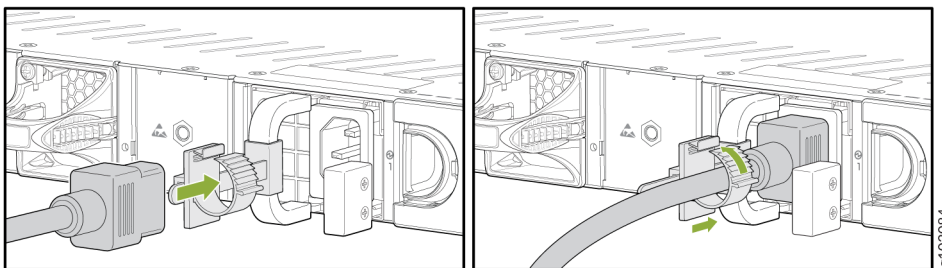

6. Repeat step 4 and step 5 to insert the second power cord.
7. If the AC power source outlet has a power switch, set it to the off (0) position.
8. Insert the power cord plug into an AC power source outlet.



NOTE: Connect each power supply to a dedicated AC power feed and a dedicated 2-pole external circuit breaker. We recommend that you use a 10 A (250 VAC), or as permitted by the local code.

9. If the AC power source outlet has a power switch, set it to the on (I) position.

Connect DC Power to the SRX1600

You connect DC power to the firewall by attaching power cables from the external DC power sources to the terminal studs on the power supply faceplates.



CAUTION: You must not mix AC and DC power supplies in the same chassis.



WARNING: Before you connect power to the firewall, a licensed electrician must attach appropriate cable terminals to the grounding and power cables that you use. A cable with an incorrectly attached terminal can damage the device (for example, by causing a short circuit).

To meet safety and electromagnetic interference (EMI) requirements and to ensure proper operation, you must properly ground the chassis before connecting power. See ["Connect Earth Ground to the SRX1600" on page 56](#) for instructions.



WARNING: Before performing the following procedure, ensure that you remove the power from the DC circuit. To ensure that all power is off, locate the circuit breaker on the panel board that services the DC circuit. Switch the circuit breaker to the OFF position (O), and tape the switch handle of the circuit breaker in the OFF position.

The power cables for the DC PSUs are rated 16AWG. To connect the DC source power cables to the firewall for each PSU:

1. Switch off the dedicated facility circuit breakers. Ensure that the voltage across the DC power source cable leads is 0 V. You must ensure that the cable leads do not become active during installation.
2. Install heat-shrink tubing insulation around the power cables:
 - a. Slide the tubing over the portion of the cable where it is attached to the terminal barrel. Ensure that the tubing covers the end of the wire and the barrel of the lug attached to it.

- b. Shrink the tubing with a heat gun. Ensure that you heat all sides of the tubing evenly so that it shrinks around the cable tightly.



NOTE: Make sure that you do not overheat the tubing.

Figure 36 on page 61 shows how to install heat-shrink tubing.

Figure 36: How to Install Heat-Shrink Tubing

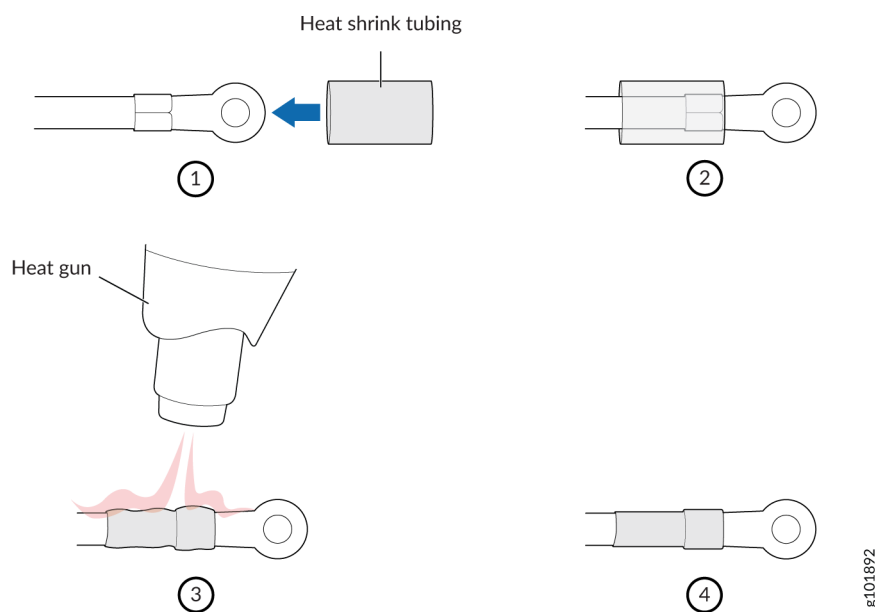

3. Remove the clear plastic cover that protects the terminal studs on the faceplate.
4. Verify that you have correctly labeled the DC power cables before making connections to the power supply.

In a typical power distribution scheme where the return is connected to chassis ground at the battery plant, you can use a multimeter to verify the ohm output of the -48V and return (RTN) DC cables to chassis ground. The cable with very large resistance (indicating an open circuit) to chassis ground will be -48V. The cable with very low resistance (indicating a closed circuit) to chassis ground will be RTN.



CAUTION: You must ensure that power connections maintain the proper polarity. The power source cables might be labeled (+) and (-) to indicate their polarity. There is no standard color coding for DC power cables. The color coding used by the

external DC power source at your site determines the color coding for the leads on the power cables that attach to the terminal studs on each power supply.

5. Remove the screws and square washers from the terminals, using a Phillips (+) screwdriver, number 2.
6. Secure each power cable ring terminal to the terminals with the square washers and the screws.
 - Secure each positive (+) DC source power cable ring terminal to an RTN terminal.
 - Secure each negative (-) DC source power cable ring terminal to a -48V (input) terminal.

Figure 37: Connecting the DC Power Cables

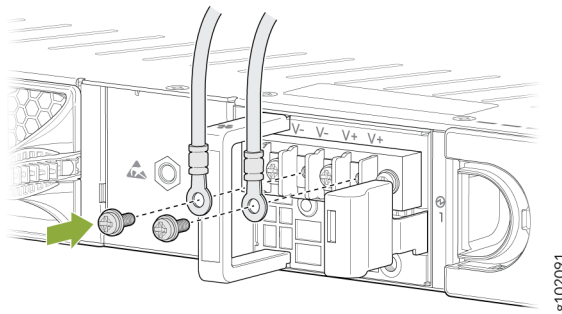

NOTE: Connect each power cable to a dedicated external circuit breaker. We recommend that you use a 10 A (80 VDC), or as permitted by the local code.

7. Replace the clear plastic cover over the terminal studs on the faceplate.
8. Verify that the power cables are connected correctly. The cables must not touch or block access to firewall components, and they must not cause a tripping hazard.
9. Switch the circuit breaker on the panel board that services the DC circuit to the ON (I) position.
10. Connect the power cables to the external DC power source. If the external DC power source has a switch, set it to the ON (I) position.

Power Off the SRX1600

You can power off the firewall in any of the following two ways:

- Graceful shutdown—Press and immediately release the Power button. The device begins gracefully shutting down the operating system (OS) and then powers itself off.



CAUTION: Use the graceful shutdown method to power off or reboot the firewall.

- Forced shutdown—Press the Power button and hold it for ten seconds. The device immediately powers itself off without shutting down the OS.



CAUTION: Use the forced shutdown method as a last resort to recover the firewall if the firewall OS is not responding to the graceful shutdown method.

To remove power completely from the firewall, unplug the AC power cord.

After powering off a power supply, wait for at least 60 seconds before turning it back on. After powering on a power supply, wait for at least 10 seconds before turning it off.

When the system is completely powered off and you turn on the power supply, the firewall starts as the power supply completes its startup sequence. If the firewall finishes starting and you need to power off the system again, first issue the `request vmhost halt` command.



NOTE: The fans in the power supply continue to rotate even after you power off the SRX1600. To stop the fans, remove the power cord from the power supply. The fans will stop in a few seconds.

After turning on the power supply, it can take up to 60 seconds for status indicators—such as the PWR LED and the `show chassis` command display—to indicate that the power supply is functioning normally. Ignore error indicators that appear during the first 60 seconds.

Connect the SRX1600 to External Devices

IN THIS SECTION

- [Connect the to a Network for Out-of-Band Management | 64](#)
- [Connect the to a Management Console Using an RJ-45 Connector | 64](#)

Connect the to a Network for Out-of-Band Management

Ensure that you have an Ethernet cable that has an RJ-45 connector at each end.

To connect a device to a network for out-of-band management:

1. Attach an electrostatic discharge (ESD) grounding strap to your bare wrist and connect the strap to one of the ESD points on the chassis.
2. Connect one end of the Ethernet cable to the management port on the device.
3. Connect the other end of the cable to the management device.

Figure 38: Connecting Your Device to a Network for Out-of-Band Management

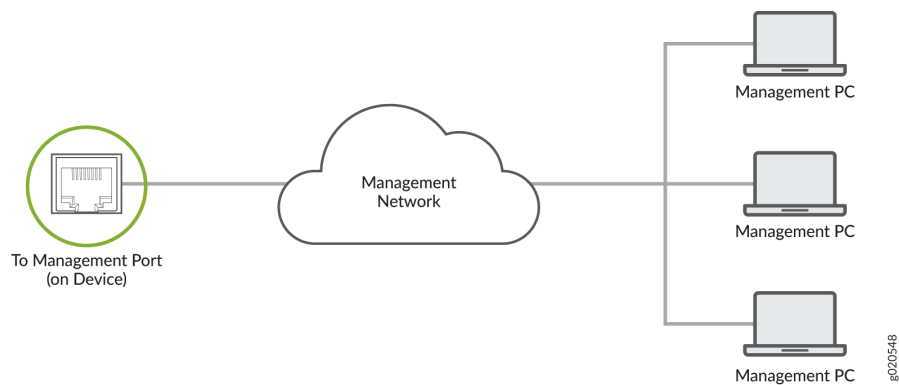

Connect the to a Management Console Using an RJ-45 Connector

Ensure that you have an Ethernet cable that has an RJ-45 connector at either end. You will also need the appropriate adapter (not provided) depending upon your console server or management console.

You can order the following separately from Juniper:

- RJ-45 to DB-9 adapter (JNP-CBL-RJ45-DB9)
- RJ-45 to USB-A adapter (JNP-CBL-RJ45-USBA)
- RJ-45 to USB-C adapter (JNP-CBL-RJ45-USBC)



NOTE: If you want to use the RJ-45 to USB-A or RJ-45 to USB-C adapter you must have X64 (64-Bit) Virtual COM port (VCP) driver installed on your PC. See <https://ftdichip.com/drivers/vcp-drivers/> to download the driver.

To connect the device to a management console:

1. Attach an electrostatic discharge (ESD) grounding strap to your bare wrist and connect the strap to one of the ESD points on the chassis.
2. Connect one end of the Ethernet cable to the console port on the device.
3. Connect the other end of the cable to the console server.

Figure 39: Connecting Your Device to a Management Console through a Console Server

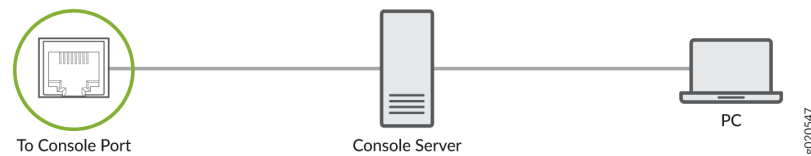

Figure 40: Connecting the Your Device directly to a Management Console



Register Products—Mandatory to Validate SLAs

Juniper Networks auto registers newly purchased products based on the end customer information provided at the point of sale. Registering products and changes to products activates your hardware replacement service-level agreements (SLAs).



CAUTION: Update the installation base data if any installation base data is added or changed or if the installation base is moved. Juniper Networks is not responsible for customers not meeting the hardware replacement service-level agreement (SLA) for products that do not have registered serial numbers or accurate installation base data. To know more about how to register your product and update your installation base, see [Juniper Networks Product Registration and Install Base Management](#).

Configure Junos OS on the SRX1600

IN THIS SECTION

- [Configure the SRX1600 Using J-Web | 66](#)
- [Configure the SRX1600 using Juniper Security Director Cloud | 67](#)
- [Access the CLI on the SRX1600 | 68](#)
- [Configure Root Authentication and Management Interface from the CLI | 68](#)
- [Factory-Default Configuration of the SRX1600 | 70](#)
- [View the SRX1600 Factory-Default Configuration | 70](#)

We ship the SRX1600 with preinstalled Junos OS, which is ready to be configured when you power on the device. You can use the J-Web GUI, Juniper® Security Director on Premise, Juniper® Security Director Cloud, or the CLI to perform the initial configuration.

Configure the SRX1600 Using J-Web

The J-Web interface is a Web-based graphical interface that allows you to operate a firewall without commands.

To access the J-Web interface on a new device that has the factory-default configuration:

1. Connect the management port (MGMT) on your device to the Ethernet port on the management device (laptop or PC), using an RJ-45 cable.

2. Manually configure the management device with a compatible IP address in the 192.168.1.0 network (for example, 192.168.1.2). Do not use the 192.168.1.1 IP address for the management device as this IP address is assigned to the fxp0 interface.
3. Open a browser and enter **https://192.168.1.1** in the address bar.

The **J-Web Setup** page opens. You can choose one of the following setup modes to configure the device:

- Standalone mode—In this mode, you can configure the basic settings such as device credentials, time, management interface, zones and interfaces, and DNS servers and default gateways.
- Cluster (HA) mode—In cluster mode, a pair of devices are connected and configured to operate like a single node, providing device, interface, and service level redundancy.
- Passive (Tap) mode—TAP mode allows you to passively monitor traffic flows across a network. If intrusion prevention system (IPS) is enabled, then the TAP mode inspects the incoming and outgoing traffic to detect the number of threats.

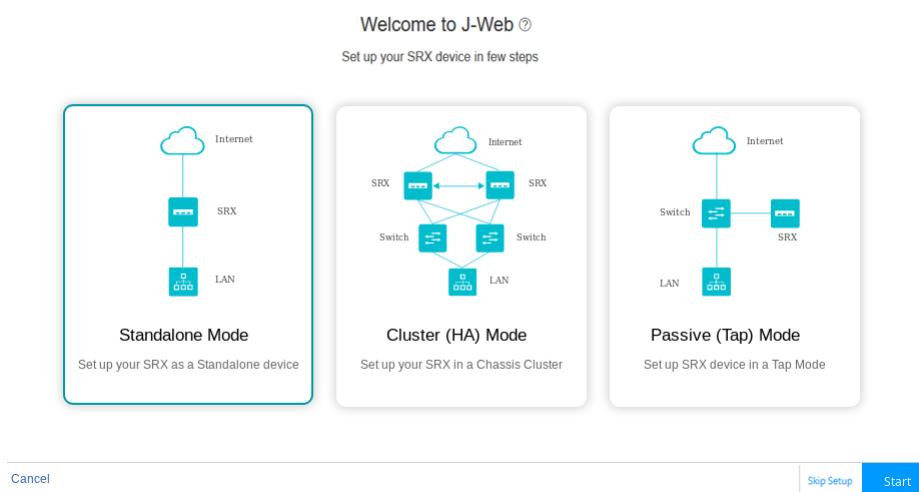

4. Select the setup mode that you want to use to configure the device and click **Start**. The **Setup Wizard** page appears.
5. Follow the instructions in [Configure SRX Devices Using the J-Web Setup Wizard](#) to configure your device.

Configure the SRX1600 using Juniper Security Director Cloud

Juniper® Security Director Cloud is a cloud-based software as a solution (SaaS) portal that helps you securely migrate your network to a Secure Access Service Edge (SASE) architecture.

Follow the instructions in the [Onboard SRX Series Firewalls to Security Director Cloud](#) guide to configure your device.

Access the CLI on the SRX1600

To access the CLI on your device:

1. Connect the management device to the serial console port as described in "[Connect the to a Management Console Using an RJ-45 Connector](#)" on page 64.
2. Start your asynchronous terminal emulation application (such as Microsoft Windows HyperTerminal) and select the appropriate COM port to use (for example, COM1).
3. Configure the serial port settings with the following values:
 - Baud rate—9600
 - Parity—N
 - Data bits—8
 - Stop bits—1
 - Flow control—none
4. Power on the device. You can start performing initial software configuration on the device after the device is up.



NOTE: After you complete the initial configuration, you can connect your device to a network for out-of-band management as described in "[Connect the to a Network for Out-of-Band Management](#)" on page 64.

Configure Root Authentication and Management Interface from the CLI

You must perform the initial configuration of the device through the console port.

Gather the following information before configuring the device:

- Root authentication
- IP address of the management interface
- Default route

To configure root authentication and the management interface:

1. Log in as root. There is no password.
2. Start the CLI and enter configuration mode.

```
root% cli
root@>configure
root@#
```

3. Set the root authentication password. You can enter a cleartext password, an encrypted password, or an SSH public key string (DSA or RSA).

```
[edit]
root@# set system root-authentication plain-text-password
New password: password
Retype new password: password
```

4. Commit the configuration to activate it on the device.

```
[edit]
root@# commit
```

5. Configure the IP address and prefix length for the Ethernet management interface on the device.

```
[edit]
root@# set interfaces fxp0 unit 0 family inet address address/prefix-length
```

6. Configure the default route.

```
[edit]
root@# set routing-options static route 0.0.0.0/0 next-hop gateway
```

7. Enable Web access to launch J-Web.

```
[edit]
root@# set system services web-management http
```

8. Commit the configuration changes.

```
[edit]  
root@# commit
```

Factory-Default Configuration of the SRX1600

Your firewall comes configured with a factory-default configuration. The default configuration includes the following security configuration:

- Two security zones are created: trust and untrust.
- A security policy is created that permits outbound traffic from the trust zone to the untrust zone.
- Source Network Address Translation (NAT) is configured on the trust zone.

If the current active configuration fails, you can use the `load factory-default` command to revert to the factory-default configuration.

View the SRX1600 Factory-Default Configuration

To view the factory-default configuration of the firewall using the CLI:

1. Log in as the root user and provide your credentials.
2. View the list of default configuration files:

```
root@srx1600>file list /etc/config
```

3. View the required default configuration file.

```
root@srx1600>file show /etc/config/config-file-name
```

5

CHAPTER

Maintaining Components

IN THIS CHAPTER

- Routine Maintenance Procedures for the SRX1600 | 72
 - SRX1600 Cooling System Maintenance | 72
 - SRX1600 Power Supply Maintenance | 74
-

Routine Maintenance Procedures for the SRX1600

To maintain optimum performance of the device, you must regularly perform the following preventive maintenance procedures:

- Inspect the installation site for moisture, loose wires or cables, and excessive dust.
- Ensure unobstructed airflow around the device and into the air intake vents.
- Check the status LEDs on the front panel of the device.

SRX1600 Cooling System Maintenance

SUMMARY

Maintaining the SRX1600 includes removing and installing the fans.

IN THIS SECTION

- [Remove the Fan Module from the SRX1600 | 73](#)
- [Install the Fan Module in the SRX1600 | 73](#)

The SRX1600 has three independent, field-replaceable fans at the rear of the chassis.

Each fan module is a hot-removable and hot-insertable field-replaceable unit (FRU). You can remove and replace the fan module without turning off power to the appliance or disrupting its functions.

Before you replace a fan module:

- Ensure that you understand how to prevent electrostatic discharge (ESD) damage.
- Ensure that you have the following parts and tools:
 - An ESD grounding strap
 - An antistatic bag or an antistatic mat
 - A replacement fan module
 - (Optional) A Phillips (+) screwdriver, number 1 or 2, for the captive screws

Remove the Fan Module from the SRX1600



CAUTION: Do not remove a fan unless a replacement fan is available.

To remove a fan:

1. Wrap and fasten one end of the ESD grounding strap around your bare wrist, and connect the other end of the strap to one of the ESD points on the chassis.
2. Place the antistatic bag or the antistatic mat on a flat, stable surface.
3. Loosen the captive screws on the front faceplate of the fan module by using your fingers. If you can't loosen the captive screws by using your fingers, use the screwdriver.



WARNING: To prevent injury, do not touch the fan with your hands or any tools when you slide the fan module out of the chassis—the fan might still be running.

4. Grasp the handle on the fan module and pull it firmly to slide the fan out of the chassis.

Figure 41: Remove the Fan Module from the SRX1600

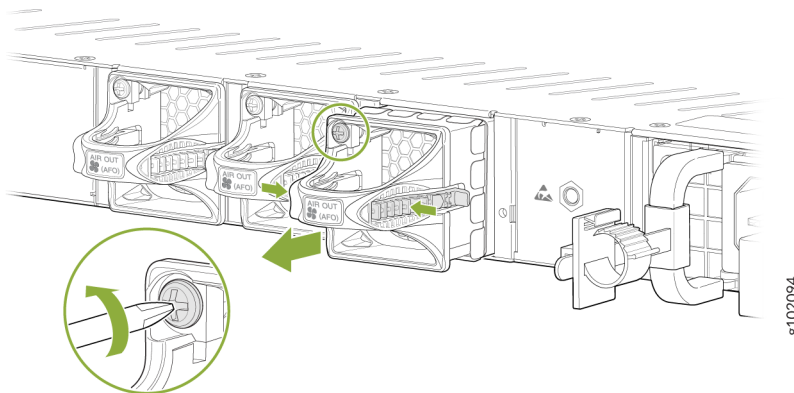

5. Place the fan module in the antistatic bag or on the antistatic mat.

Install the Fan Module in the SRX1600

To install a fan:

1. Wrap and fasten one end of the ESD grounding strap around your bare wrist, and connect the other end of the strap to one of the ESD points on the chassis.
2. Remove the fan module from its bag.
3. Hold the handle of the fan module with one hand and support the weight of the module with the other hand. Place the fan module in the fan module slot on the rear panel of the switch and slide the module in until it is fully seated.

Figure 42: Install the Fan Module on the SRX1600

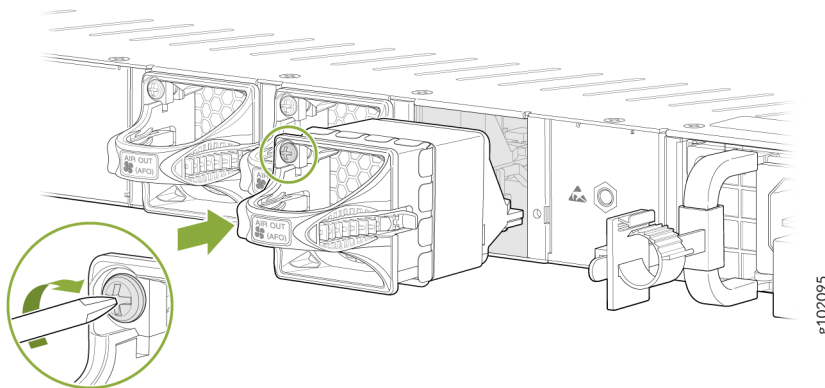

4. Tighten the captive screws on the faceplate of the fan module by using your fingers. If you can't tighten the captive screws by using your fingers, use the screwdriver.

SRX1600 Power Supply Maintenance

SUMMARY

Maintaining an SRX1600 includes removing a failed power supply unit (PSU) and installing a functional PSU.

IN THIS SECTION

- [Replace an AC PSU on the SRX1600 | 75](#)
- [Replace a DC PSU on the SRX1600 | 77](#)

Replace an AC PSU on the SRX1600

IN THIS SECTION

- [Remove the AC PSU from the SRX1600 | 75](#)
- [Install the AC PSU in the SRX1600 | 76](#)

The SRX1600 rear panel has two AC PSUs which are hot-removable and hot-insertable field-replaceable units (FRUs). You can remove and replace the PSUs without powering off the SRX1600 or disrupting the firewall functions.

Ensure that you have the following parts and tools:

- An electrostatic discharge (ESD) grounding strap
- An antistatic bag or an antistatic mat
- A replacement AC PSU
- A blank cover panel (in case you're not replacing the component)

Remove the AC PSU from the SRX1600

To remove an AC PSU from the appliance (see [Figure 43 on page 76](#)):



CAUTION: Avoid leaving the PSU slot empty for more than 30 minutes when the device is operational. For proper airflow, you must place the PSU in the chassis. Always cover the empty PSU slot with a blank panel.

1. If the AC power source outlet has a power switch, set it to the off (O) position.
2. Pull out the power cord connected to the power source outlet.
3. Place the antistatic bag or the antistatic mat on a flat, stable surface.
4. Attach an ESD grounding strap to your bare wrist and connect the strap to the ESD point on the chassis.
5. Unplug the power cord from the device inlet on the PSU.
6. Press the latch, which is on the right side of the power outlet, to the left.
7. Pull the PSU straight out of the chassis.

Figure 43: Remove an SRX1600 AC PSU

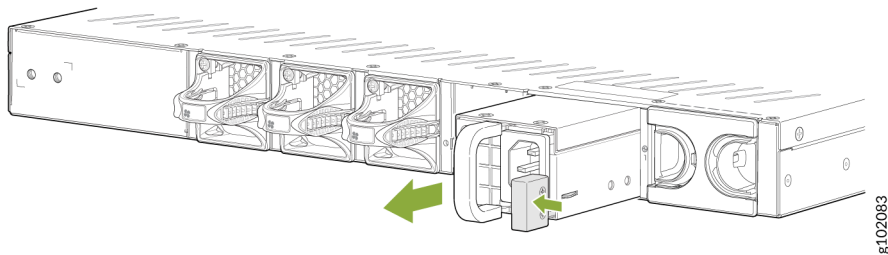

g102083

8. Place the PSU in the antistatic bag or on the antistatic mat that you've placed on a flat, stable surface.
9. If you're not replacing the power supply, install the cover panel over the PSU slot.

Install the AC PSU in the SRX1600

To install an AC PSU (see [Figure 44 on page 76](#)):

1. Attach the ESD grounding strap to your bare wrist, and connect the strap to the ESD point on the chassis.
2. If the PSU slot has a cover panel on it, remove the cover panel. Save the cover panel for subsequent use.
3. Taking care not to touch power supply pins, leads, or solder connections on the PSU, remove the PSU from the bag.
4. Using both hands, place the PSU in the PSU slot on the rear panel of the SRX1600. Slide the PSU straight into the chassis until the PSU is fully seated in the chassis slot. Ensure that the PSU faceplate is flush with the adjacent PSU faceplate.

Figure 44: Install an SRX1600 AC PSU

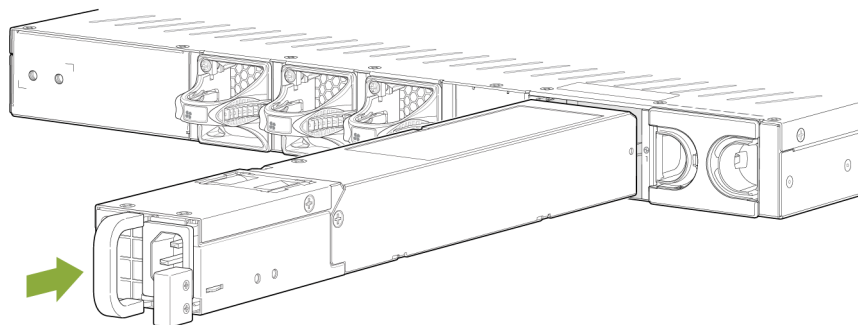

g102082

5. Connect the power cord (see ["Connect the SRX1600 to Power" on page 56](#)).

Replace a DC PSU on the SRX1600

IN THIS SECTION

- [Remove the DC PSU from an SRX1600 | 77](#)
- [Install the DC PSU in the SRX1600 | 78](#)

The rear panel of the SRX1600 has two DC PSUs, which are hot-removable and hot-insertable field-replaceable units (FRUs). You can remove and replace the PSUs without powering off the SRX1600 or disrupting the firewall functions.

Ensure that you the following parts and tools are available:

- An ESD grounding strap
- An antistatic bag or an antistatic mat
- A replacement DC PSU
- A blank cover panel (in case you're not replacing the component)

Remove the DC PSU from an SRX1600

To remove a DC PSU from the appliance (see [Figure 45 on page 78](#)):



CAUTION: Avoid leaving the PSU slot empty for more than 30 minutes when the device is operational. For proper airflow, you must place the PSU in the chassis. Always cover the empty PSU slot with a blank panel.

1. Attach an ESD grounding strap to your bare wrist and connect the strap to the ESD point on the chassis.
2. Place the antistatic bag or the antistatic mat on a flat, stable surface.
3. Switch off the external circuit breakers for all the cables connected to the PSU. Make sure that the voltage across the power source cable leads is 0 V. You must remove any possibility for the cables to become active during the removal process.
4. Remove the clear plastic cover protecting the terminal studs from the faceplate.
5. Remove the screws and washers from the terminals using a number 2 Phillips screwdriver.
6. Remove the cable terminals from the terminal studs. Carefully move the power cables out of the way.

7. Press the latch, which is on the right side of the power outlet, to the left.
8. Pull the PSU straight out of the chassis.

Figure 45: Remove an SRX1600 DC PSU

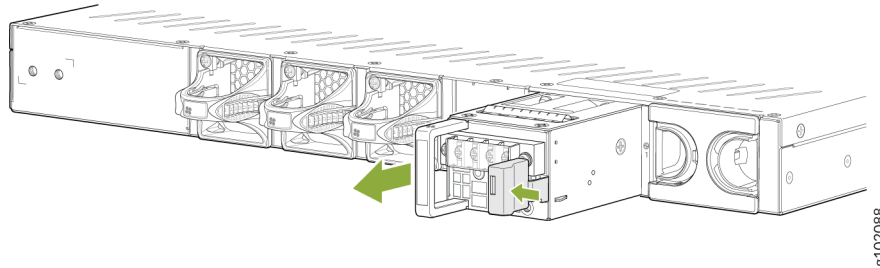

9. Place the PSU in the antistatic bag or on the antistatic mat that you've placed on a flat, stable surface.
10. If you're not replacing the power supply, install the cover panel over the slot.

Install the DC PSU in the SRX1600

To install a DC PSU (see [Figure 46 on page 79](#)):

1. Attach the ESD grounding strap to your bare wrist, and connect the strap to the ESD point on the chassis.
2. Switch off the circuit breaker on the panel board that services the DC circuit. Tape the handle of the circuit breaker in the OFF position. Make sure that the voltage across the power source cable leads is 0 V. You must remove any possibility for the cables to become active during the removal process.
3. If the PSU slot has a cover panel on it, remove the cover panel. Save the cover panel for subsequent use.
4. Taking care not to touch the power supply terminals, leads, or solder connections on the PSU, remove the PSU from the bag.
5. Using both hands, place the PSU in the PSU slot on the rear panel of the SRX1600. Slide the PSU straight into the chassis until the PSU is fully seated in the chassis slot. Ensure that the PSU faceplate is flush with the adjacent PSU faceplate.

Figure 46: Install an SRX1600 DC PSU

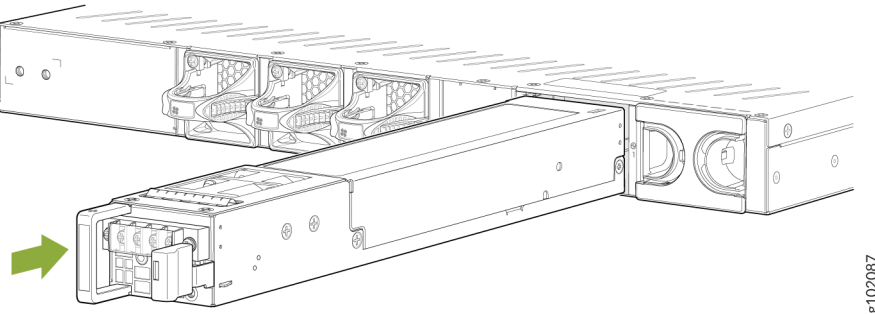

6. Tighten the captive screws on the lower edge of the PSU faceplate.
7. Connect the power cables (see ["Connect the SRX1600 to Power" on page 56](#)).

6

CHAPTER

Troubleshooting Hardware

IN THIS CHAPTER

- [Troubleshoot the SRX1600 | 81](#)
-

Troubleshoot the SRX1600

IN THIS SECTION

- [Troubleshooting Resources for the SRX1600 Firewall | 81](#)
- [Troubleshooting Chassis and Interface Alarm Messages on the SRX1600 Firewall | 81](#)
- [Troubleshooting the Power System on the SRX1600 | 83](#)
- [Using the RESET Button | 84](#)

Troubleshooting Resources for the SRX1600 Firewall

To troubleshoot a device, you use the Junos OS CLI and the LEDs on the components:

- LEDs—When the device detects an alarm condition, the alarm LED on the interfaces glows red or yellow.
- CLI—The CLI is the primary tool for controlling and troubleshooting hardware, Junos OS, and network connectivity. Use the CLI to see more information about alarms. CLI command outputs display information about network connectivity, which Junos derives from the ping and traceroute utilities.

For information about using the CLI to troubleshoot Junos OS, see the appropriate Junos OS configuration guide.

- JTAC—If you need assistance during troubleshooting, you can contact the Juniper Networks Technical Assistance Center (JTAC) by using the Web or by telephone. If you encounter software problems, or problems with hardware components not discussed here, contact JTAC.

Troubleshooting Chassis and Interface Alarm Messages on the SRX1600 Firewall

When the firewall detects an alarm condition, the alarm LED on the interfaces glows red or yellow on the front panel as appropriate. To view a more detailed description of the alarm condition, issue the `show chassis alarms` command.

Alarm messages belong to two classes:

- Chassis alarms—Indicate a problem with a chassis component such as the cooling system or PSU.
- Interface alarms—Indicate a problem with a specific network interface.

For more information about the `show chassis alarms` command, see [Network Management and Monitoring Guide](#).

[Table 32 on page 82](#) describes alarms that can occur for a firewall chassis component.

Table 32: Alarms for Firewall Chassis Components

Components	Alarm Conditions	Action	Alarm Severity
Boot media	If the internal flash fails at startup, the firewall automatically boots from the alternative boot device (USB storage device).	If you configured the firewall to boot from an alternative boot device, ignore this alarm condition. If you did not configure the firewall to boot from an alternative boot device, contact JTAC.	Yellow (minor)
Hardware components on the firewall	The firewall chassis temperature is too high.	<ul style="list-style-type: none"> • Check the room temperature. See "Environmental Requirements and Specifications for SRX1600" on page 36. • Check the airflow. See "Clearance Requirements for Hardware Maintenance of the SRX1600" on page 37. 	Yellow (minor)
	The firewall fan has failed.	Place your hand near the exhaust vents at the rear of the chassis to determine whether the fan is pushing air out of the chassis.	Red (major)



NOTE: For more information about alarms, see the Junos OS Monitoring and Troubleshooting for Security Devices Guide.

Troubleshooting the Power System on the SRX1600

The LEDs on the firewall enable you to determine the performance and operation of the power system. The PWR LED located on the front panel of the firewall, as described in "[Chassis Status LEDs](#)" on page 15, indicates the different status settings of the power system.

Table 33: PWR LED Description

LED Status	LED State	Meaning	Possible Cause and Corrective Action
Green	On	The firewall is receiving power, and all the AC or DC power supply units (PSUs) are working properly.	The power system is normal and no action is required.
Red	On	One or more PSUs have failed.	<p>If you cannot determine the cause of the problem or need additional assistance:</p> <ul style="list-style-type: none"> • Open a support case using the Service Request Manager link at https://www.juniper.net/support/. • Call 1-888-314-JTAC (if you're within the United States) or 1-408-745-9500 (if you're outside the United States).
Blinking green	On	The firewall, which is in the bootup phase before Junos OS initialization, is receiving power.	The power system is normal and no action is required.

Table 33: PWR LED Description (*Continued*)

LED Status	LED State	Meaning	Possible Cause and Corrective Action
Off	Off	The firewall is not receiving power.	<p data-bbox="987 373 1409 436">Issue the <code>show chassis alarms</code> command to determine the source of the problem.</p> <ul data-bbox="987 472 1417 1192" style="list-style-type: none"> <li data-bbox="987 472 1417 640">• Verify that the AC power cord or DC power supply cable is not damaged. If the insulation is cracked or broken, immediately replace the cord or cable. <li data-bbox="987 676 1417 814">• Verify that the source circuit breaker has the proper current rating. Each PSU must be connected to a separate source circuit breaker. <li data-bbox="987 850 1417 951">• Ensure that the power socket into which you have plugged the device is working. <li data-bbox="987 987 1417 1192">• Connect the PSUs to a different power source with a new power cord or power cables. If the LEDs on the PSUs indicate that the PSU is not functioning normally, replace the PSU with a spare. <p data-bbox="1013 1228 1417 1360">NOTE: If the system temperature exceeds the threshold, Junos OS shuts down all the PSUs and the LED stops indicating the status.</p> <p data-bbox="1013 1375 1417 1543">Junos OS also can shut down one of the PSUs for other reasons. In this case, the remaining PSU provides power to the firewall. You can view the system status through the CLI.</p>

Using the RESET Button

If a configuration fails or denies management access to the firewall, you can use the RESET button to restore the device.

The RESET CONFIG button is recessed to prevent it from being pressed accidentally. To press the RESET button, insert a small probe (such as a straightened paper clip) into the pinhole on the front panel.

- Pressing the RESET button for about 250 milliseconds will reboot the device.
- Pressing and holding the RESET button for more than 10 seconds will reboot the device and recover the primary BIOS.

7

CHAPTER

Contact Customer Support and Returning the Chassis or Components

IN THIS CHAPTER

- [Contacting Customer Support and Returning the Chassis or Components | 87](#)
-

Contacting Customer Support and Returning the Chassis or Components

SUMMARY

If you need to return a hardware component to Juniper Networks, Inc., you need a Return Material Authorization (RMA) number and the equipment serial number. Contact the Juniper Networks Technical Assistance Center (JTAC) to generate an RMA number. You may also need to locate the chassis or component details using the CLI or by referring to equipment labels. You then pack and ship the component.

IN THIS SECTION

- [How to Return a Hardware Component to Juniper Networks | 87](#)
- [Locate the Chassis Serial Number ID Label | 88](#)
- [Contact Customer Support to Obtain Return Material Authorization | 89](#)
- [Guidelines for Packing and Shipping Hardware Components | 90](#)

How to Return a Hardware Component to Juniper Networks

If a hardware component fails, contact Juniper Networks to obtain an RMA number. We use this number to track the returned material at the factory and to return the repaired or new components to you, as needed.



NOTE: Do not return any component to Juniper Networks unless you have first obtained an RMA number. Juniper Networks reserves the right to refuse shipments that do not have an RMA number. Refused shipments are returned to you by collect freight.

For more information about return and repair policies, see the **Support** page at <https://support.juniper.net/support/>.

For product problems or technical support issues, contact JTAC in one of the following ways:

- On the Web—Go to <https://www.juniper.net/support/> and use the **Case Manager** link to open a support case.
- By telephone:
 - From the U.S. and Canada: 1-888-314-JTAC (5822)
 - From all other locations: 1-408-745-9500



NOTE: If you're contacting JTAC by telephone:

- To report a new incident, press the star (*) key to be routed to the next available support engineer.
- To enquire about an existing case, enter your 12-digit service request number followed by the pound (#) key.

To return a defective hardware component:

1. Determine the part number and the serial number of the defective component.
2. Obtain an RMA number from JTAC. You can open a support case or contact JTAC by telephone, as described above.
3. Provide the following information to JTAC:
 - Part number and serial number of the component
 - Your name, organization name, telephone number, and fax number
 - Description of the failure

The support representative validates your request and issues an RMA number for return of the component.

4. Pack the component for shipment. See "[Guidelines for Packing and Shipping Hardware Components](#)" on page 90.

Locate the Chassis Serial Number ID Label

[Figure 47 on page 89](#) shows the location of the chassis serial number ID label.



NOTE: For international or direct-dial options in countries without toll-free numbers, see <https://support.juniper.net/support/>.

If you contact JTAC by telephone:

- To report a new incident, press the star (*) key to be routed to the next available support engineer.
- To enquire about an existing case, enter your 12-digit service request number followed by the pound (#) key.

The support representative validates your request and issues an RMA number for return of the component.

Guidelines for Packing and Shipping Hardware Components

To pack and ship individual components:

1. When you return the chassis or components, make sure to adequately protect them with packing materials. Pack them properly to prevent the pieces from moving around the carton.
2. Use the original shipping materials, if they are available.
3. Place the individual components in antistatic bags.
4. Write the RMA number on the exterior of the box to ensure proper tracking.
5. Ship the package.



NOTE: Remove the power supply units (PSUs) before packing the device.



CAUTION: Avoid stacking any of the hardware components.

8

CHAPTER

Safety and Compliance Information

IN THIS CHAPTER

- Safety Information | 92
 - SRX1600 Agency Approvals | 93
-

Safety Information

IN THIS SECTION

- [Boot Time | 92](#)
- [Warning Statement for Shielded Intra-Building Criteria | 92](#)
- [Warning Statement for Unshielded Intra-Building Criteria | 92](#)

The [Juniper Networks Safety Guide](#) provides general safety information and guidelines for all Juniper Networks products. Follow the guidelines provided in the guide to reduce the likelihood of personal injury, equipment damage, and damage to surrounding areas.

Along with the information provided in the *Juniper Networks Safety Guide*, you must read and understand the SRX1600-specific safety information provided in this hardware guide.

Boot Time

The boot time for the SRX1600 is approximately 320.2 seconds.

Warning Statement for Shielded Intra-Building Criteria



WARNING: The intra-building port(s) of the equipment or subassembly must use shielded intra-building cabling or wiring that is grounded at both ends.

Warning Statement for Unshielded Intra-Building Criteria



WARNING: Certain ports of a device are designed for use as intra-building (within-the-building) interfaces only (Type 2 or Type 4 ports as described in *GR-1089-CORE*) and

require isolation from the exposed outside plant (OSP) cabling. To comply with NEBS requirements and protect against lightning surges and commercial power disturbances, the intra-building ports must not be metalically connected to interfaces that connect to the OSP or its wiring. The intra-building ports on the device are suitable for connection to intra-building or unexposed wiring or cabling only. The addition of primary protectors is not sufficient protection for connecting these interfaces metalically to OSP wiring.

SRX1600 Agency Approvals

IN THIS SECTION

- [Agency Approvals | 93](#)
- [Compliance Statements for NEBS | 95](#)
- [EMC Requirements for Japan | 95](#)
- [Compliance Statement for Argentina | 96](#)

Agency Approvals

The SRX1600 complies with the following standards:

- Safety
 - IEC 60950-1:2005, AMD 1:2009, AMD 2:2013 Information Technology Equipment
 - UL 60950-1:2007 R10.14 Information Technology Equipment
 - CAN/CSA-C22.2 No. 60950-1-07, AMD 1:2011, AMD 2:2014 Information Technology Equipment
 - IEC/EN 60825-1 Safety of Laser Products – Part 1: Equipment Classification
 - IEC 62368-1 2014 (2nd Edition) Audio/Video, Information and Communication Technology Equipment
 - IEC 62368-1 2018 (3rd Edition) Audio/Video, Information and Communication Technology Equipment

- EN 62368-1:2014+A11:2017 Audio/Video, Information and Communication Technology Equipment
- UL/CSA 62368-1 :2019 (3rd Edition) Audio/Video, Information and Communication Technology Equipment
- EMC
 - FCC 47 CFR Part 15
 - ICES-003 / ICES-GEN
 - BS EN 55032
 - BS EN 55035
 - EN 300 386 V1.6.1
 - EN 300 386 V2.2.1
 - BS EN 300 386
 - EN 55032
 - CISPR 32
 - EN 55035
 - CISPR 35
 - IEC/EN 61000 Series
 - IEC/EN 61000-3-2
 - IEC/EN 61000-3-3
 - AS/NZS CISPR 32
 - VCCI-CISPR 32
 - BSMI CNS 15936
 - KS C 9835 (Old KN 35)
 - KS C 9832 (Old KN 32)
 - KS C 9610
 - BS EN 61000 Series
 - GR3160

- VCCI 32-1
- VCCI Class A (2007) Japanese Radiated Emissions
- Environmental
 - Reduction of Hazardous Substances (RoHS) 6
 - DC NEBS
- ETSI EN-300386-2 Telecommunication Network Equipment. Electromagnetic Compatibility Requirements
- Common Language Equipment Identifier (CLEI) code

Compliance Statements for NEBS

- The equipment is suitable for installation as part of the Common Bonding Network (CBN).
- The equipment is suitable for installation in locations where the National Electrical Code (NEC) applies.
- The battery return connection is to be treated as an isolated DC return (i.e.DC-I), as defined in GR-1089-CORE.
- For Juniper Networks systems with AC power supplies, an external surge protective device (SPD) must be used at the AC power source.

EMC Requirements for Japan

この装置は、クラスA機器です。この装置を住宅環境で使用すると電波妨害を引き起こすことがあります。この場合には使用者が適切な対策を講ずるよう要求されることがあります。

VCCI - A

The preceding translates as follows:

This is a Class A product. In a domestic environment this product may cause radio interference in which case the user may be required to take adequate measures.

VCCI-A

Compliance Statement for Argentina

EQUIPO DE USO IDÓNEO.