



**Hewlett Packard**  
Enterprise

## **HPE ProLiant DL145 Gen11 Server Maintenance and Service Guide**

Part Number: 30-BB012DB9-003  
Published: October 2025  
Edition: 3

# HPE ProLiant DL145 Gen11 Server Maintenance and Service Guide

## Abstract

This document is for the person who installs, administers, and troubleshoots servers and storage systems. Hewlett Packard Enterprise assumes you are qualified in the servicing of computer equipment and trained in recognizing hazards in products with hazardous energy levels, and are familiar with the weight and stability precautions for rack installations.

Part Number: 30-BB012DB9-003

Published: October 2025

Edition: 3

© Copyright 2024–2025 Hewlett Packard Enterprise Development LP

## Notices

The information provided here is subject to change without notice. Hewlett Packard Enterprise's products and services are covered only by the express warranty statements that come with them. This document does not constitute an additional warranty. Hewlett Packard Enterprise is not responsible for any technical or editorial errors or omissions in this document.

Confidential computer software. You must have a valid license from Hewlett Packard Enterprise to possess, use, or copy the software. In accordance with FAR 12.211 and 12.212, Commercial Computer Software, Computer Software Documentation, and Technical Data for Commercial Items are licensed to the U.S. Government under the vendor's standard commercial license.

Links to third-party websites will take you outside of the Hewlett Packard Enterprise website. Hewlett Packard Enterprise has no control over and is not responsible for the information outside the Hewlett Packard Enterprise website.

## Acknowledgments

AMD and AMD EPYC™ are trademarks of Advanced Micro Devices, Inc.

Linux® is the registered trademark of Linus Torvalds in the U.S. and other countries.

Microsoft®, Windows®, and Windows Server® are either registered trademarks or trademarks of Microsoft Corporation in the United States and/or other countries.

All third-party marks are property of their respective owners.

## Table of contents

- Customer self repair
- Illustrated parts catalog
  - Mechanical components
    - Front bezel assembly spare part
    - Drive blank spare parts
    - E3.S drive cage filler spare part
    - Rack rail spare part
    - Cable management arm spare part
  - System components
    - Power supply spare parts
    - iLO service port cable spare part
    - Chassis intrusion detection switch spare part
    - Fan spare parts
    - DIMM spare parts
    - Processor spare parts
    - Heatsink spare part
    - Power distribution board (PDB) and cable spare parts
    - System battery spare part
    - System board spare part
  - Server options
    - Wall mount / desktop installation kit spare part
    - Rack mount bracket spare part
    - Two-post rack support bracket spare part
    - RJ45-serial port cable spare part
    - Energy pack spare part
    - Drive backplane spare parts
    - Drive cable spare parts
    - Drive cage spare parts
    - Riser board spare parts
    - Storage controller spare parts
    - Boot device bracket spare part
    - HPE NS204i-u Boot Device spare parts
- Removal and replacement procedures
  - Safety considerations
    - Electrostatic discharge
    - Symbols on equipment
    - Rack warnings and cautions
    - Server warnings and cautions
  - Preparation procedures

- Server data backup
- Remove the front bezel
- Power down the server
- Open the cable management arm
- Extend the server from the rack
- Remove the server from a four-post rack
- Remove the server from a two-post rack
- Remove the access panel
- Remove the air baffle
- Remove the three-slot riser cage
- Remove the drive base cage with the SFF/E3.S drive cage installed
- Power up the server
- Removing and replacing the front bezel assembly
- Front bezel filter replacement
  - Front bezel filter maintenance guidelines
  - Removing and replacing the front bezel filter
  - Resetting the iLO filter change timer
- Removing and replacing a hot-plug SFF/E3.S drive
- Removing and replacing a drive blank
- Removing and replacing an E3.S drive cage filler
- Flexible Slot power supply replacement
  - Power supply warnings and cautions
  - DC power supply warnings and cautions
  - Removing and replacing a Flexible Slot power supply
- Removing and replacing the side covers
- Removing and replacing the wall mount connecting brackets
- Removing and replacing the cable management arm
- Removing and replacing the rack rails
- Removing and replacing the rack mount brackets
- Removing and replacing the two-post rack support brackets
- Removing and replacing a fan
- Removing and replacing a DIMM
- Removing and replacing the 2 SFF drive cage
- Removing and replacing the E3.S drive cage
- Removing and replacing the 6 E3.S enablement cable on the E3.S drive cage
- Drive backplane replacement
  - Removing and replacing the 2 SFF drive backplane
  - Removing and replacing the 4 E3.S drive backplane
- Expansion card replacement
  - Removing and replacing an expansion card in the three-slot riser cage
- Removing and replacing a type-o storage controller

- Riser board replacement
  - Removing and replacing the base riser in the three-slot riser cage
  - Removing and replacing a stacking riser in the three-slot riser cage
- Removing and replacing the OCP 3.0 NIC
- HPE NS204i-u Boot Device replacement
  - Removing and replacing a boot device drive in the boot device bracket
  - Removing and replacing the HPE NS204i-u Boot Device cage assembly in the boot device bracket
  - Removing and replacing the boot device bracket
- Removing and replacing the iLO service port cable
- Removing and replacing the RJ45-serial port cable
- Removing and replacing the energy pack
- Removing and replacing the chassis intrusion detection switch
- Heatsink replacement
  - Heatsink label
  - Removing the heatsink
  - Installing the heatsink
- Processor replacement
  - Processor cautions
  - Removing the processor
  - Installing the processor
  - Reconfiguring the system date and time settings
- Removing and replacing the power distribution board (PDB)
- System board replacement
  - Removing the system board
  - Installing the system board
  - Re-entering the server serial number and product ID
- System battery replacement
  - System battery information
  - Removing and replacing the system battery
- Troubleshooting
  - NMI functionality
  - Troubleshooting resources
- Configuration resources
  - Updating firmware or system ROM
  - Configuring the server
  - Configuring storage controllers
  - Deploying an OS
  - Configuring security
  - Server management
  - Managing Linux-based high performance compute clusters
- Component identification

- Front panel components
  - iLO Service Port
  - Display device setup
- Front panel LEDs and buttons
  - Server UID LED
  - Viewing the Server Health Summary
  - Front panel LED power fault codes
- Component touchpoints
- System board components
  - System maintenance switch descriptions
  - DIMM label identification
  - DIMM slot numbering
  - Processor and socket components
- Riser board components
- Riser slot numbering
- HPE Basic Drive LED definitions
- EDSFF SSD LED definitions
- Drive bay numbering
  - SFF drive bay numbering
  - E3.S drive bay numbering
- Drive backplane naming
- GPU numbering
- Power distribution board (PDB) components
- Fan numbering
  - Fan and heatsink requirements
- Trusted Platform Module 2.0
  - Trusted Platform Module 2.0 guidelines
  - BitLocker recovery key/password retention guidelines
- HPE NS204i-u Boot Device components
- HPE NS204i-u Boot Device LED definitions
- Cabling
  - Cabling guidelines
  - Cabling diagrams
  - Internal cabling management
  - Stacking riser cabling
  - Storage cabling
    - Storage controller cabling
      - 2 SFF SATA/NVMe drive controller cabling
      - 4 E3.S NVMe drive controller cabling
      - 4 + 2 E3.S NVMe drive controller cabling
    - Drive power cabling

- Energy pack cabling
- Storage controller backup power cabling
- HPE NS204i-u Boot Device cabling
- iLO service port cabling
- RJ45-serial port cabling
- Ambient temperature sensor cabling
- System power cabling
- Chassis intrusion detection switch cabling
- Specifications
  - Environmental specifications
  - Mechanical specifications
  - Power supply specifications
    - HPE 700 W Flex Slot Platinum Hot-plug Power Supply
    - HPE 700 W Flex Slot -48 VDC Hot-plug Low Halogen Power Supply
    - HPE 900 W-1000 W Flex Slot Titanium Hot-plug Power Supply
- Websites
- Support and other resources
  - Accessing Hewlett Packard Enterprise Support
  - Accessing updates
  - Remote support
  - Warranty information
  - Regulatory information
  - Documentation feedback

## Customer self repair

Hewlett Packard Enterprise products are designed with many Customer Self Repair (CSR) parts to minimize repair time and allow for greater flexibility in performing defective parts replacement. If during the diagnosis period Hewlett Packard Enterprise (or Hewlett Packard Enterprise service providers or service partners) identifies that the repair can be accomplished by the use of a CSR part, Hewlett Packard Enterprise will ship that part directly to you for replacement. There are two categories of CSR parts:

- **Mandatory**—Parts for which customer self repair is mandatory. If you request Hewlett Packard Enterprise to replace these parts, you will be charged for the travel and labor costs of this service.
- **Optional**—Parts for which customer self repair is optional. These parts are also designed for customer self repair. If, however, you require that Hewlett Packard Enterprise replace them for you, there may or may not be additional charges, depending on the type of warranty service designated for your product.



### NOTE

Some Hewlett Packard Enterprise parts are not designed for customer self repair. In order to satisfy the customer warranty, Hewlett Packard Enterprise requires that an authorized service provider replace the part. These parts are identified as "No" in the Illustrated Parts Catalog.

Based on availability and where geography permits, CSR parts will be shipped for next business day delivery. Same day or four-hour delivery may be offered at an additional charge where geography permits. If assistance is required, you can contact the Hewlett Packard Enterprise Support Center and a technician will help you over the telephone or by electronic means. Hewlett Packard Enterprise specifies in the materials shipped with a replacement CSR part whether a defective part must be returned to Hewlett Packard Enterprise. In cases where it is required to return the defective part to Hewlett Packard Enterprise, you must ship the defective part back to Hewlett Packard Enterprise within a defined period of time, normally five (5) business days. The defective part must be returned with the associated documentation in the provided shipping material. Failure to return the defective part may result in Hewlett Packard Enterprise billing you for the replacement. With a customer self repair, Hewlett Packard Enterprise will pay all shipping and part return costs and determine the courier/carrier to be used.

For more information about the Hewlett Packard Enterprise CSR program, contact your local service provider.

## Parts only warranty service

Your Hewlett Packard Enterprise Limited Warranty may include a parts only warranty service. Under the terms of parts only warranty service, Hewlett Packard Enterprise will provide replacement parts free of charge.

For parts only warranty service, CSR part replacement is mandatory. If you request Hewlett Packard Enterprise to replace these parts, you will be charged for the travel and labor costs of this service.

## Réparation par le client (CSR)

Les produits Hewlett Packard Enterprise comportent de nombreuses pièces CSR (Customer Self Repair = réparation par le client) afin de minimiser les délais de réparation et faciliter le remplacement des pièces défectueuses. Si pendant la période de diagnostic, Hewlett Packard Enterprise (ou ses partenaires ou mainteneurs agréés) détermine que la réparation peut être effectuée à l'aide d'une pièce CSR, Hewlett Packard Enterprise vous l'envoie directement. Il existe deux catégories de pièces CSR :

- **Obligatoire**—Pièces pour lesquelles la réparation par le client est obligatoire. Si vous demandez à Hewlett Packard Enterprise de remplacer ces pièces, les coûts de déplacement et main d'œuvre du service vous seront facturés.
- **Facultatif**—Pièces pour lesquelles la réparation par le client est facultative. Ces pièces sont également conçues pour permettre au client d'effectuer lui-même la réparation. Toutefois, si vous demandez à Hewlett Packard Enterprise de remplacer ces pièces, l'intervention peut ou non vous être facturée, selon le type de garantie applicable à votre produit.

**REMARQUE:** Certaines pièces Hewlett Packard Enterprise ne sont pas conçues pour permettre au client d'effectuer lui-même la réparation. Pour que la garantie puisse s'appliquer, Hewlett Packard Enterprise exige que le remplacement de la pièce soit effectué par un Mainteneur Agréé. Ces pièces sont identifiées par la mention "Non" dans le Catalogue illustré.

Les pièces CSR sont livrées le jour ouvré suivant, dans la limite des stocks disponibles et selon votre situation géographique. Si votre situation géographique le permet et que vous demandez une livraison le jour même ou dans les 4 heures, celle-ci vous sera facturée. Pour toute assistance, appelez le Centre d'assistance Hewlett Packard Enterprise pour qu'un technicien vous aide au téléphone. Dans les documents envoyés avec la pièce de rechange CSR, Hewlett Packard Enterprise précise s'il est nécessaire de lui retourner la pièce défectueuse. Si c'est le cas, vous devez le faire dans le délai indiqué, généralement cinq (5) jours ouvrés. La pièce et sa documentation doivent être retournées dans l'emballage fourni. Si vous ne retournez pas la pièce défectueuse, Hewlett Packard Enterprise se réserve le droit de vous facturer les coûts de remplacement. Dans le cas d'une pièce CSR, Hewlett Packard Enterprise supporte l'ensemble des frais

d'expédition et de retour, et détermine la société de courses ou le transporteur à utiliser.

Pour plus d'informations sur le programme CSR de Hewlett Packard Enterprise, contactez votre Mainteneur Agréé local.

## Service de garantie "pièces seules"

Votre garantie limitée Hewlett Packard Enterprise peut inclure un service de garantie "pièces seules". Dans ce cas, les pièces de rechange fournies par Hewlett Packard Enterprise ne sont pas facturées.

Dans le cadre de ce service, la réparation des pièces CSR par le client est obligatoire. Si vous demandez à Hewlett Packard Enterprise de remplacer ces pièces, les coûts de déplacement et main d'œuvre du service vous seront facturés.

## Riparazione da parte del cliente

Per abbreviare i tempi di riparazione e garantire una maggiore flessibilità nella sostituzione di parti difettose, i prodotti Hewlett Packard Enterprise sono realizzati con numerosi componenti che possono essere riparati direttamente dal cliente (CSR, Customer Self Repair). Se in fase di diagnostica Hewlett Packard Enterprise (o un centro di servizi o di assistenza Hewlett Packard Enterprise) identifica il guasto come riparabile mediante un ricambio CSR, Hewlett Packard Enterprise lo spedisce direttamente al cliente per la sostituzione. Vi sono due categorie di parti CSR:

- **Obbligatorie**—Parti che devono essere necessariamente riparate dal cliente. Se il cliente ne affida la riparazione ad Hewlett Packard Enterprise, deve sostenere le spese di spedizione e di manodopera per il servizio.
- **Opzionali**—Parti la cui riparazione da parte del cliente è facoltativa. Si tratta comunque di componenti progettati per questo scopo. Se tuttavia il cliente ne richiede la sostituzione ad Hewlett Packard Enterprise, potrebbe dover sostenere spese aggiuntive a seconda del tipo di garanzia previsto per il prodotto.

**NOTA:** alcuni componenti Hewlett Packard Enterprise non sono progettati per la riparazione da parte del cliente. Per rispettare la garanzia, Hewlett Packard Enterprise richiede che queste parti siano sostituite da un centro di assistenza autorizzato. Tali parti sono identificate da un "No" nel Catalogo illustrato dei componenti.

In base alla disponibilità e alla località geografica, le parti CSR vengono spedite con consegna entro il giorno lavorativo seguente. La consegna nel giorno stesso o entro quattro ore è offerta con un supplemento di costo solo in alcune zone. In caso di necessità si può richiedere l'assistenza telefonica di un addetto del centro di supporto tecnico Hewlett Packard Enterprise. Nel materiale fornito con una parte di ricambio CSR, Hewlett Packard Enterprise specifica se il cliente deve restituire dei componenti. Qualora sia richiesta la resa ad Hewlett Packard Enterprise del componente difettoso, lo si deve spedire ad Hewlett Packard Enterprise entro un determinato periodo di tempo, generalmente cinque (5) giorni lavorativi. Il componente difettoso deve essere restituito con la documentazione associata nell'imballo di spedizione fornito. La mancata restituzione del componente può comportare la fatturazione del ricambio da parte di Hewlett Packard Enterprise. Nel caso di riparazione da parte del cliente, Hewlett Packard Enterprise sostiene tutte le spese di spedizione e resa e sceglie il corriere/vettore da utilizzare.

Per ulteriori informazioni sul programma CSR di Hewlett Packard Enterprise, contattare il centro di assistenza di zona.

## Servizio di garanzia per i soli componenti

La garanzia limitata Hewlett Packard Enterprise può includere un servizio di garanzia per i soli componenti. Nei termini di garanzia del servizio per i soli componenti, Hewlett Packard Enterprise fornirà gratuitamente le parti di ricambio.

Per il servizio di garanzia per i soli componenti è obbligatoria la formula CSR che prevede la riparazione da parte del cliente. Se il cliente invece richiede la sostituzione ad Hewlett Packard Enterprise dovrà sostenere le spese di spedizione e di manodopera per il servizio.

## Customer Self Repair

Hewlett Packard Enterprise Produkte enthalten viele CSR-Teile (Customer Self Repair), um Reparaturzeiten zu minimieren und höhere Flexibilität beim Austausch defekter Bauteile zu ermöglichen. Wenn Hewlett Packard Enterprise (oder ein Hewlett Packard Enterprise Servicepartner) bei der Diagnose feststellt, dass das Produkt mithilfe eines CSR-Teils repariert werden kann, sendet Ihnen Hewlett Packard Enterprise dieses Bauteil zum Austausch direkt zu. CSR-Teile werden in zwei Kategorien unterteilt:

- **Zwingend**—Teile, für die das Customer Self Repair-Verfahren zwingend vorgegeben ist. Wenn Sie den Austausch dieser Teile von Hewlett Packard Enterprise vornehmen lassen, werden Ihnen die Anfahrt- und Arbeitskosten für diesen Service berechnet.
- **Optional**—Teile, für die das Customer Self Repair-Verfahren optional ist. Diese Teile sind auch für Customer Self Repair ausgelegt. Wenn Sie jedoch den Austausch dieser Teile von Hewlett Packard Enterprise vornehmen lassen möchten, können bei diesem Service je nach den für Ihr Produkt vorgesehenen Garantiebedingungen zusätzliche Kosten anfallen.

**HINWEIS:** Einige Hewlett Packard Enterprise Teile sind nicht für Customer Self Repair ausgelegt. Um den Garantieanspruch des Kunden zu erfüllen, muss das Teil von einem Hewlett Packard Enterprise Servicepartner ersetzt werden. Im illustrierten Teilekatalog sind diese Teile mit „No“ bzw. „Nein“ gekennzeichnet.

CSR-Teile werden abhängig von der Verfügbarkeit und vom Lieferziel am folgenden Geschäftstag geliefert. Für bestimmte Standorte ist eine Lieferung am selben Tag oder innerhalb von vier Stunden gegen einen Aufpreis verfügbar. Wenn Sie Hilfe benötigen, können Sie das Hewlett Packard Enterprise Support Center anrufen und sich von einem Mitarbeiter per Telefon helfen lassen. Den Materialien von Hewlett Packard Enterprise, die mit einem CSR-Ersatzteil geliefert werden, können Sie entnehmen, ob das defekte Teil an Hewlett Packard Enterprise zurückgeschickt werden muss. Wenn es erforderlich ist, das defekte Teil an Hewlett Packard Enterprise zurückzuschicken, müssen Sie dies innerhalb eines vorgegebenen Zeitraums tun, in der Regel innerhalb von fünf (5) Geschäftstagen. Das defekte Teil muss mit der zugehörigen Dokumentation in der Verpackung zurückgeschickt werden, die im Lieferumfang enthalten ist. Wenn Sie das defekte Teil nicht zurückschicken, kann Hewlett Packard Enterprise Ihnen das Ersatzteil in Rechnung stellen. Im Falle von Customer Self Repair kommt Hewlett Packard Enterprise für alle Kosten für die Lieferung und Rücksendung auf und bestimmt den Kurier-/Frachtdienst.

Weitere Informationen über das Hewlett Packard Enterprise Customer Self Repair Programm erhalten Sie von Ihrem Servicepartner vor Ort.

## Parts-only Warranty Service (Garantieservice ausschließlich für Teile)

Ihre Hewlett Packard Enterprise Garantie umfasst möglicherweise einen Parts-only Warranty Service (Garantieservice ausschließlich für Teile). Gemäß den Bestimmungen des Parts-only Warranty Service stellt Hewlett Packard Enterprise Ersatzteile kostenlos zur Verfügung.

Für den Parts-only Warranty Service ist das CSR-Verfahren zwingend vorgegeben. Wenn Sie den Austausch dieser Teile von Hewlett Packard Enterprise vornehmen lassen, werden Ihnen die Anfahrt- und Arbeitskosten für diesen Service berechnet.

## Reparaciones del propio cliente

Los productos de Hewlett Packard Enterprise incluyen muchos componentes que el propio usuario puede reemplazar (Customer Self Repair, CSR) para minimizar el tiempo de reparación y ofrecer una mayor flexibilidad a la hora de realizar sustituciones de componentes defectuosos. Si, durante la fase de diagnóstico, Hewlett Packard Enterprise (o los proveedores o socios de servicio de Hewlett Packard Enterprise) identifica que una reparación puede llevarse a cabo mediante el uso de un componente CSR, Hewlett Packard Enterprise le enviará dicho componente directamente para que realice su sustitución. Los componentes CSR se clasifican en dos categorías:

- **Obligatorio**—Componentes cuya reparación por parte del usuario es obligatoria. Si solicita a Hewlett Packard Enterprise que realice la sustitución de estos componentes, tendrá que hacerse cargo de los gastos de desplazamiento y de mano de obra de dicho servicio.
- **Opcional**—Componentes cuya reparación por parte del usuario es opcional. Estos componentes también están diseñados para que puedan ser reparados por el usuario. Sin embargo, si precisa que Hewlett Packard Enterprise realice su sustitución, puede o no conllevar costes adicionales, dependiendo del tipo de servicio de garantía correspondiente al producto.

**NOTA:** Algunos componentes de Hewlett Packard Enterprise no están diseñados para que puedan ser reparados por el usuario. Para que el usuario haga valer su garantía, Hewlett Packard Enterprise pone como condición que un proveedor de servicios autorizado realice la sustitución de estos componentes. Dichos componentes se identifican con la palabra "No" en el catálogo ilustrado de componentes.

Según la disponibilidad y la situación geográfica, los componentes CSR se enviarán para que lleguen a su destino al siguiente día laborable. Si la situación geográfica lo permite, se puede solicitar la entrega en el mismo día o en cuatro horas con un coste adicional. Si precisa asistencia técnica, puede llamar al Centro de asistencia técnica de Hewlett Packard Enterprise y recibirá ayuda telefónica por parte de un técnico. Con el envío de materiales para la sustitución de componentes CSR, Hewlett Packard Enterprise especificará si los componentes defectuosos deberán devolverse a Hewlett Packard Enterprise. En aquellos casos en los que sea necesario devolver algún componente a Hewlett Packard Enterprise, deberá hacerlo en el periodo de tiempo especificado, normalmente cinco días laborables. Los componentes defectuosos deberán devolverse con toda la documentación relacionada y con el embalaje de envío. Si no enviara el componente defectuoso requerido, Hewlett Packard Enterprise podrá cobrarle por el de sustitución. En el caso de todas sustituciones que lleve a cabo el cliente, Hewlett Packard Enterprise se hará cargo de todos los gastos de envío y devolución de componentes y escogerá la empresa de transporte que se utilice para dicho servicio.

Para obtener más información acerca del programa de Reparaciones del propio cliente de Hewlett Packard Enterprise, póngase en contacto con su proveedor de servicios local.

## Servicio de garantía exclusivo de componentes

La garantía limitada de Hewlett Packard Enterprise puede que incluya un servicio de garantía exclusivo de componentes. Según las condiciones de este servicio exclusivo de componentes, Hewlett Packard Enterprise le facilitará los componentes de repuesto sin cargo adicional alguno.

Para este servicio de garantía exclusivo de componentes, es obligatoria la sustitución de componentes por parte del usuario (CSR). Si solicita a Hewlett Packard Enterprise que realice la sustitución de estos componentes, tendrá que hacerse cargo de los gastos de desplazamiento y de mano de obra de dicho servicio.

## Customer Self Repair

Veel onderdelen in Hewlett Packard Enterprise producten zijn door de klant zelf te repareren, waardoor de reparatieduur tot een minimum beperkt kan blijven en de flexibiliteit in het vervangen van defecte onderdelen groter is. Deze onderdelen worden CSR-onderdelen (Customer Self Repair) genoemd. Als Hewlett Packard Enterprise (of een Hewlett Packard Enterprise Service Partner) bij de diagnose vaststelt dat de reparatie kan worden uitgevoerd met een CSR-onderdeel, verzendt Hewlett Packard Enterprise dat onderdeel rechtstreeks

naar u, zodat u het defecte onderdeel daarmee kunt vervangen. Er zijn twee categorieën CSR-onderdelen:

- **Verplicht**—Onderdelen waarvoor reparatie door de klant verplicht is. Als u Hewlett Packard Enterprise verzoekt deze onderdelen voor u te vervangen, worden u voor deze service reiskosten en arbeidsloon in rekening gebracht.
- **Optioneel**—Onderdelen waarvoor reparatie door de klant optioneel is. Ook deze onderdelen zijn ontworpen voor reparatie door de klant. Als u echter Hewlett Packard Enterprise verzoekt deze onderdelen voor u te vervangen, kunnen daarvoor extra kosten in rekening worden gebracht, afhankelijk van het type garanteservice voor het product.

**OPMERKING:** Sommige Hewlett Packard Enterprise onderdelen zijn niet ontwikkeld voor reparatie door de klant. In verband met de garantievoorzwaarden moet het onderdeel door een geautoriseerde Service Partner worden vervangen. Deze onderdelen worden in de geïllustreerde onderdelencatalogus aangemerkt met "Nee".

Afhankelijk van de leverbaarheid en de locatie worden CSR-onderdelen verzonden voor levering op de eerstvolgende werkdag. Levering op dezelfde dag of binnen vier uur kan tegen meerkosten worden aangeboden, indien dit mogelijk is gezien de locatie. Indien assistentie is gewenst, belt u het Hewlett Packard Enterprise Support Center om via de telefoon ondersteuning van een technicus te ontvangen. Hewlett Packard Enterprise vermeldt in de documentatie bij het vervangende CSR-onderdeel of het defecte onderdeel aan Hewlett Packard Enterprise moet worden geretourneerd. Als het defecte onderdeel aan Hewlett Packard Enterprise moet worden teruggezonden, moet u het defecte onderdeel binnen een bepaalde periode, gewoonlijk vijf (5) werkdagen, retourneren aan Hewlett Packard Enterprise. Het defecte onderdeel moet met de bijbehorende documentatie worden geretourneerd in het meegeleverde verpakkingsmateriaal. Als u het defecte onderdeel niet terugzendt, kan Hewlett Packard Enterprise u voor het vervangende onderdeel kosten in rekening brengen. Bij reparatie door de klant betaalt Hewlett Packard Enterprise alle verzendkosten voor het vervangende en geretourneerde onderdeel en kiest Hewlett Packard Enterprise zelf welke koerier/transportonderneming hiervoor wordt gebruikt.

Neem contact op met een Service Partner voor meer informatie over het Customer Self Repair programma van Hewlett Packard Enterprise.

## Garanteservice "Parts Only"

Het is mogelijk dat de Hewlett Packard Enterprise garantie alleen de garanteservice "Parts Only" omvat. Volgens de bepalingen van de Parts Only garanteservice zal Hewlett Packard Enterprise kosteloos vervangende onderdelen ter beschikking stellen.

Voor de Parts Only garanteservice is vervanging door CSR-onderdelen verplicht. Als u Hewlett Packard Enterprise verzoekt deze onderdelen voor u te vervangen, worden u voor deze service reiskosten en arbeidsloon in rekening gebracht

## Reparo feito pelo cliente

Os produtos da Hewlett Packard Enterprise são projetados com muitas peças para reparo feito pelo cliente (CSR) de modo a minimizar o tempo de reparo e permitir maior flexibilidade na substituição de peças com defeito. Se, durante o período de diagnóstico, a Hewlett Packard Enterprise (ou fornecedores/parceiros da Hewlett Packard Enterprise) concluir que o reparo pode ser efetuado pelo uso de uma peça CSR, a Hewlett Packard Enterprise enviará a peça diretamente ao cliente. Há duas categorias de peças CSR:

- **Obrigatória**—Peças cujo reparo feito pelo cliente é obrigatório. Se desejar que a Hewlett Packard Enterprise substitua essas peças, serão cobradas as despesas de transporte e mão-de-obra do serviço.
- **Opcional**—Peças cujo reparo feito pelo cliente é opcional. Essas peças também são projetadas para o reparo feito pelo cliente. No entanto, se desejar que a Hewlett Packard Enterprise as substitua, pode haver ou não a cobrança de taxa adicional, dependendo do tipo de serviço de garantia destinado ao produto.

**OBSERVAÇÃO:** Algumas peças da Hewlett Packard Enterprise não são projetadas para o reparo feito pelo cliente. A fim de cumprir a garantia do cliente, a Hewlett Packard Enterprise exige que um técnico autorizado substitua a peça. Essas peças estão identificadas com a marca "No" (Não), no catálogo de peças ilustrado.

Conforme a disponibilidade e o local geográfico, as peças CSR serão enviadas no primeiro dia útil após o pedido. Onde as condições geográficas permitirem, a entrega no mesmo dia ou em quatro horas pode ser feita mediante uma taxa adicional. Se precisar de auxílio, entre em contato com o Centro de suporte técnico da Hewlett Packard Enterprise para que um técnico o ajude por telefone. A Hewlett Packard Enterprise especifica nos materiais fornecidos com a peça CSR de reposição se a peça com defeito deve ser devolvida à Hewlett Packard Enterprise. Nos casos em que isso for necessário, é preciso enviar a peça com defeito à Hewlett Packard Enterprise, você deverá enviar a peça com defeito de volta para a Hewlett Packard Enterprise dentro do período de tempo definido, normalmente em 5 (cinco) dias úteis. A peça com defeito deve ser enviada com a documentação correspondente no material de transporte fornecido. Caso não o faça, a Hewlett Packard Enterprise poderá cobrar a reposição. Para as peças de reparo feito pelo cliente, a Hewlett Packard Enterprise paga todas as despesas de transporte e de devolução da peça e determina a transportadora/serviço postal a ser utilizado.

Para obter mais informações sobre o programa de reparo feito pelo cliente da Hewlett Packard Enterprise, entre em contato com o fornecedor de serviços local.

## Serviço de garantia apenas para peças

A garantia limitada da Hewlett Packard Enterprise pode incluir um serviço de garantia apenas para peças. Segundo os termos do serviço de garantia apenas para peças, a Hewlett Packard Enterprise fornece as peças de reposição sem cobrar nenhuma taxa.

## カスタマーセルフリペア

修理時間を短縮し、故障部品の交換における高い柔軟性を確保するために、Hewlett Packard Enterprise製品には多数のカスタマーセルフリペア（CSR）部品があります。診断の際に、CSR部品を使用すれば修理ができるHewlett Packard Enterprise（Hewlett Packard EnterpriseまたはHewlett Packard Enterprise正規保守代理店）が判断した場合、Hewlett Packard Enterpriseはその部品を直接、お客様に発送し、お客様に交換していただきます。CSR部品には以下の2種類があります。

- **必須** - カスタマーセルフリペアが必須の部品。当該部品について、もしもお客様がHewlett Packard Enterpriseに交換作業を依頼される場合には、その修理サービスに関する交通費および人件費がお客様に請求されます。
- **任意** - カスタマーセルフリペアが任意である部品。この部品もカスタマーセルフリペア用です。当該部品について、もしもお客様がHewlett Packard Enterpriseに交換作業を依頼される場合には、お買い上げの製品に適用される保証サービス内容の範囲内においては、別途費用を負担していただくことなく保証サービスを受けることができます。

**注：** Hewlett Packard Enterprise製品の一部の部品は、カスタマーセルフリペアの対象外です。製品の保証を継続するためには、Hewlett Packard EnterpriseまたはHewlett Packard Enterprise正規保守代理店による交換作業が必須となります。部品カタログには、当該部品がカスタマーセルフリペア除外品である旨が記載されています。

部品供給が可能な場合、地域によっては、CSR部品を翌営業日に届くように発送します。また、地域によっては、追加費用を負担いただくことにより同日または4時間以内に届くように発送することも可能な場合があります。サポートが必要なときは、Hewlett Packard Enterpriseサポートセンターに電話していただければ、技術者が電話でアドバイスします。交換用のCSR部品または同梱物には、故障部品をHewlett Packard Enterpriseに返送する必要があるかどうかが表示されています。故障部品をHewlett Packard Enterpriseに返送する必要がある場合は、指定期限内（通常は5営業日以内）に故障部品をHewlett Packard Enterpriseに返送してください。故障部品を返送する場合は、届いた時の梱包箱に関連書類とともに入れてください。故障部品を返送しない場合、Hewlett Packard Enterpriseから部品費用が請求されます。カスタマーセルフリペアの際には、Hewlett Packard Enterpriseは送料および部品返送費を全額負担し、使用する宅配便会社や運送会社を指定します。

## 部品のみ保証サービス

Hewlett Packard Enterprise保証サービスには、部品のみ保証サービスが適用される場合があります。このサービスでは、交換部品は無償で提供されます。

部品のみ保証サービスにおいては、CSR部品をお客様により交換作業していただくことが必須となります。当該部品について、もしもお客様がHewlett Packard Enterpriseに交換作業を依頼される場合には、その修理サービスに関する交通費および人件費がお客様のご負担となります。

# 客户自行维修

Hewlett Packard Enterprise 产品提供许多客户自行维修 (CSR) 部件，以尽可能缩短维修时间和在更换缺陷部件方面提供更大的灵活性。如果在诊断期间 Hewlett Packard Enterprise (或 Hewlett Packard Enterprise 服务提供商或服务合作伙伴) 确定可以通过使用 CSR 部件完成维修，Hewlett Packard Enterprise 将直接把该部件发送给您进行更换。有两类 CSR 部件：

- **强制性的** — 要求客户必须自行维修的部件。如果您请求 Hewlett Packard Enterprise 更换这些部件，则必须为该服务支付差旅费和人工费用。
- **可选的** — 客户可以选择是否自行维修的部件。这些部件也是为客户自行维修设计的。不过，如果您要求 Hewlett Packard Enterprise 为您更换这些部件，则根据为您的产品指定的保修服务类型，Hewlett Packard Enterprise 可能收取或不再收取任何附加费用。

**注：**某些 Hewlett Packard Enterprise 部件的设计并未考虑客户自行维修。为了满足客户保修的需要，Hewlett Packard Enterprise 要求授权服务提供商更换相关部件。这些部件在部件图解目录中标记为“否”。

CSR 部件将在下一个工作日发运（取决于备货情况和允许的地理范围）。在允许的地理范围内，可在当天或四小时内发运，但要收取额外费用。如果需要帮助，您可以致电 Hewlett Packard Enterprise 技术支持中心，将会有技术人员通过电话为您提供帮助。Hewlett Packard Enterprise 会在随更换的 CSR 部件发运的材料中指明是否必须将有缺陷的部件返还给 Hewlett Packard Enterprise。如果要求您将有缺陷的部件返还给 Hewlett Packard Enterprise，那么您必须在规定的期限内（通常是五 (5) 个工作日）将缺陷部件发给 Hewlett Packard Enterprise。有缺陷的部件必须随所提供的发运材料中的相关文件一起返还。如果未能送还有缺陷的部件，Hewlett Packard Enterprise 可能会要求您支付更换费用。客户自行维修时，Hewlett Packard Enterprise 将承担所有相关运输和部件返回费用，并指定快递商/承运商。

有关 Hewlett Packard Enterprise 客户自行维修计划的详细信息，请与您当地的服务提供商联系。

## 仅部件保修服务

您的 Hewlett Packard Enterprise 有限保修服务可能涉及仅部件保修服务。根据仅部件保修服务条款的规定，Hewlett Packard Enterprise 将免费提供更换的部件。

仅部件保修服务要求进行 CSR 部件更换。如果您请求 Hewlett Packard Enterprise 更换这些部件，则必须为该服务支付差旅费和人工费用。

# 客戶自行維修

Hewlett Packard Enterprise 產品設計了許多「客戶自行維修」(CSR) 的零件以減少維修時間，並且使得更換瑕疵零件時能有更大的彈性。如果在診斷期間，Hewlett Packard Enterprise (或 Hewlett Packard Enterprise 服務供應商或維修夥伴) 辨認出此項維修工作可以藉由使用 CSR 零件來完成，則 Hewlett Packard Enterprise 將直接寄送該零件給您作更換。CSR 零件分為兩種類別：

- **強制的** — 客戶自行維修所使用的零件是強制性的。如果您要求 Hewlett Packard Enterprise 更換這些零件，Hewlett Packard Enterprise 將會向您收取此服務所需的外出費用與勞動成本。
- **選購的** — 客戶自行維修所使用的零件是選購的。這些零件也設計用於客戶自行維修之用。不過，如果您要求 Hewlett Packard Enterprise 為您更換，則可能需要也可能不需要負擔額外的費用，端視針對此產品指定的保固服務類型而定。

**備註：**某些 Hewlett Packard Enterprise 零件沒有消費者可自行維修的設計。為符合客戶保固，Hewlett Packard Enterprise 需要授權的服務供應商更換零件。這些零件在圖示的零件目錄中，被標示為「否」。

基於材料取得及環境允許的情況下，CSR 零件將於下一個工作日以快遞寄送。在環境的允許下當天或四小時內送達，則可能需要額外的費用。若您需要協助，可致電 Hewlett Packard Enterprise 支援中心，會有一位技術人員透過電話來協助您。不論損壞的零件是否必須退回，Hewlett Packard Enterprise 皆會在與 CSR 替換零件一起運送的材料中註明。若要將損壞的零件退回 Hewlett Packard Enterprise，您必須在指定的一段時間內 (通常為五 (5) 個工作天)，將損壞的零件寄回 Hewlett Packard Enterprise。損壞的零件必須與寄送資料中隨附的相關技術文件一併退還。如果無法退還損壞的零件，Hewlett Packard Enterprise 可能要向您收取替換費用。針對客戶自行維修情形，Hewlett Packard Enterprise 將負責所有運費及零件退還費用，並指定使用何家快遞/貨運公司。

如需 Hewlett Packard Enterprise 的 CSR 方案詳細資訊，請連絡您當地的服務供應商。

## 僅限零件的保固服務

您的「Hewlett Packard Enterprise 有限保固」可能包含僅限零件的保固服務。在僅限零件的保固服務情況下，Hewlett Packard Enterprise 將免費提供替換零件。

針對僅限零件的保固服務，CSR 零件替換是強制性的。如果您要求 Hewlett Packard Enterprise 更換這些零件，Hewlett Packard Enterprise 將會向您收取此服務所需的外出費用與勞動成本。

# 고객 셀프 수리

Hewlett Packard Enterprise 제품은 수리 시간을 최소화하고 결함이 있는 부품 교체 시 더욱 융통성을 발휘할 수 있도록 하기 위해 고객 셀프 수리(CSR) 부품을 다량 사용하여 설계되었습니다. 진단 기간 동안 Hewlett Packard Enterprise(또는 Hewlett Packard Enterprise 서비스 공급업체 또는 서비스 협력업체)에서 CSR 부품을 사용하여 수리가 가능하다고 판단되면 Hewlett Packard Enterprise는 해당 부품을 바로 사용자에게 보내어 사용자가 교체할 수 있도록 합니다. CSR 부품에는 두 가지 종류가 있습니다.

- 필수 - 고객 셀프 수리가 의무 사항인 필수 부품. 사용자가 Hewlett Packard Enterprise에 이 부품의 교체를 요청할 경우 이 서비스에 대한 출장비 및 작업비가 청구됩니다.
- 선택 사항 - 고객 셀프 수리가 선택 사항인 부품. 이 부품들도 고객 셀프 수리가 가능하도록 설계되었습니다. 하지만 사용자가 Hewlett Packard Enterprise에 이 부품의 교체를 요청할 경우 사용자가 구입한 제품에 해당하는 보증 서비스 유형에 따라 추가 비용 없이 교체가 가능할 수 있습니다.

참고: 일부 Hewlett Packard Enterprise 제품은 고객 셀프 수리가 불가능하도록 설계되었습니다. Hewlett Packard Enterprise는 만족스러운 고객 보증을 위해 공인 서비스 제공업체를 통해 부품을 교체하도록 하고 있습니다. 이러한 부품들은 Illustrated Parts Catalog에 "No"라고 표시되어 있습니다.

CSR 부품은 재고 상태와 지리적 조건이 허용하는 경우 다음 영업일 납품이 가능하도록 배송이 이루어집니다. 지리적 조건이 허용하는 경우 추가 비용이 청구되는 조건으로 당일 또는 4시간 배송이 가능할 수도 있습니다. 도움이 필요하시면 Hewlett Packard Enterprise Support Center로 전화하십시오. 전문 기술자가 전화로 도움을 줄 것입니다. Hewlett Packard Enterprise는 결함이 발생한 부품을 Hewlett Packard Enterprise로 반환해야 하는지 여부를 CSR 교체 부품과 함께 배송된 자료에 지정합니다. 결함이 발생한 부품을 Hewlett Packard Enterprise로 반환해야 하는 경우에는 지정된 기간 내(통상 영업일 기준 5일)에 Hewlett Packard Enterprise로 반환해야 합니다. 이때 결함이 발생한 부품은 제공된 포장 재료에 넣어 관련 설명서와 함께 반환해야 합니다. 결함이 발생한 부품을 반환하지 않는 경우 Hewlett Packard Enterprise가 교체 부품에 대해 비용을 청구할 수 있습니다. 고객 셀프 수리의 경우, Hewlett Packard Enterprise는 모든 운송 및 부품 반환 비용을 부담하며 이용할 운송업체 및 택배 서비스를 결정합니다.

Hewlett Packard Enterprise CSR 프로그램에 대한 자세한 내용은 가까운 서비스 제공업체에 문의하십시오.

## 부품 제공 보증 서비스

Hewlett Packard Enterprise 제한 보증에는 부품 제공 보증 서비스가 포함될 수 있습니다. 이러한 경우 Hewlett Packard Enterprise는 부품 제공 보증 서비스의 조건에 따라 교체 부품만을 무료로 제공합니다.

부품 제공 보증 서비스 제공 시 CSR 부품 교체는 의무 사항입니다. 사용자가 Hewlett Packard Enterprise에 이 부품의 교체를 요청할 경우 이 서비스에 대한 출장비 및 작업비가 청구됩니다.

## Illustrated parts catalog

This chapter lists the hardware spare parts supported by the server.

### Subtopics

[Mechanical components](#)

[System components](#)

[Server options](#)

## Mechanical components

Hewlett Packard Enterprise continually improves and changes product parts. For complete and current supported spare parts information, see the Hewlett Packard Enterprise PartSurfer website:

<https://www.hpe.com/info/partssurfer>

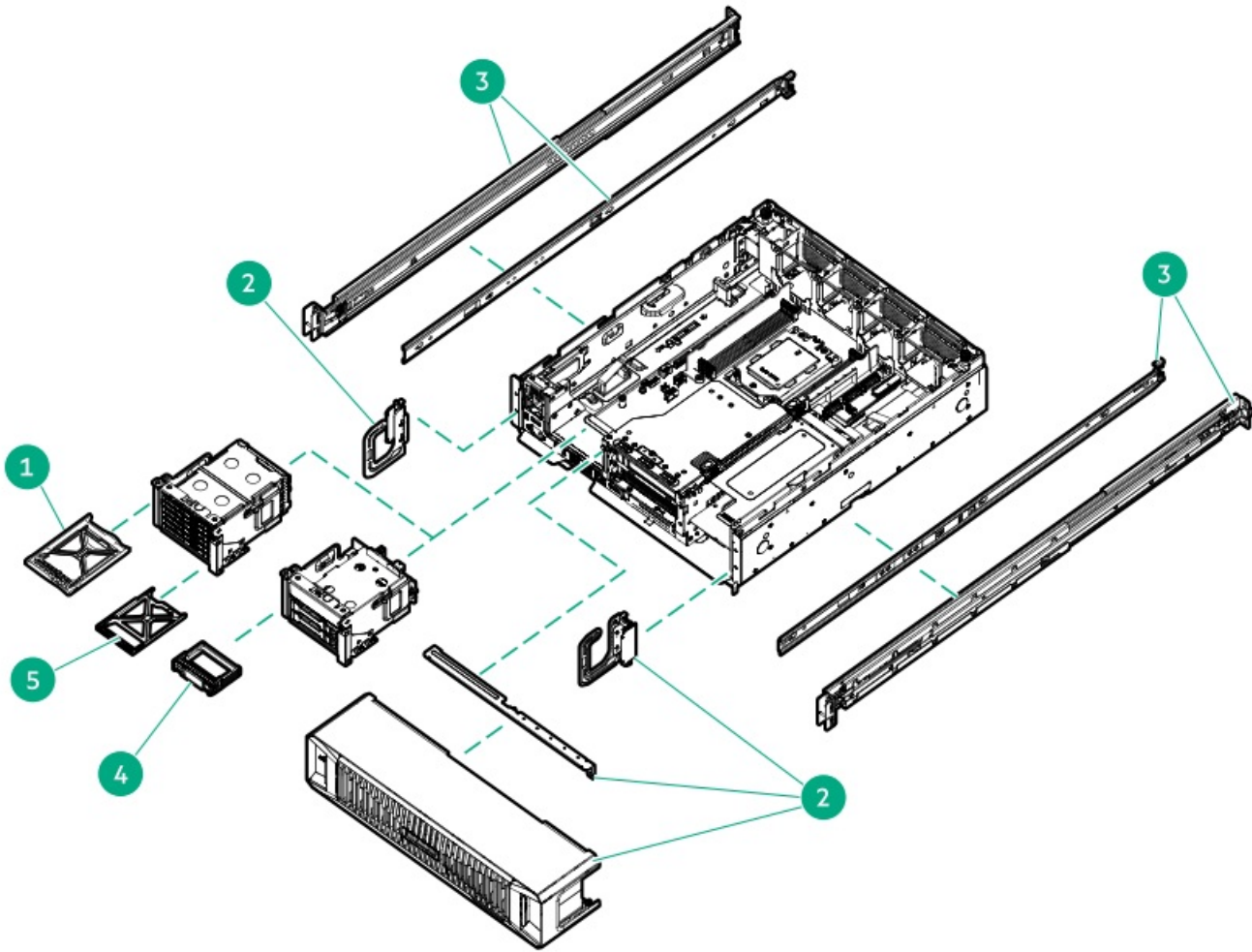

Item	Description
1	<a href="#">E3.S drive blank spare part</a>
2	<a href="#">Front bezel assembly spare part</a>
3	<a href="#">Rack rail spare part</a>
4	<a href="#">SFF drive blank spare part</a>
5	<a href="#">E3.S drive cage filler spare part</a>
6	<a href="#">Cable management arm spare part</a> *

\* Not shown

#### Subtopics

[Front bezel assembly spare part](#)

[Drive blank spare parts](#)

[E3.S drive cage filler spare part](#)

[Rack rail spare part](#)

[Cable management arm spare part](#)

## Front bezel assembly spare part

Customer self repair: Mandatory

Description	Spare part number
Front bezel assembly, includes: P74765-001	
<ul style="list-style-type: none"> <li>• Font bezel</li> <li>• Bezel bracket</li> <li>• Cabling brackets</li> </ul>	

For more information on the removal and replacement procedures, see [Removing and replacing the front bezel assembly](#).

## Drive blank spare parts

Customer self repair: Mandatory

Description	Spare part number
SFF drive blank	809955-001
E3.S drive blank	P52488-001

For more information on the removal and replacement procedures, see [Removing and replacing a drive blank](#).

## E3.S drive cage filler spare part

Customer self repair: Mandatory

Description	Spare part number
E3.S drive cage filler	P74372-001

For more information on the removal and replacement procedures, see [Removing and replacing an E3.S drive cage filler](#).

## Rack rail spare part

Customer self repair: Mandatory

Description	Spare part number
Friction rack rail #1 (left and right rails)	P59489-001

For more information on the removal and replacement procedures, see [Removing and replacing the rack rails](#).

## Cable management arm spare part

Customer self repair: Mandatory

HPE cable management arm for friction rack rail #1, #2, #3 or #5 P38900-001

For more information on the removal and replacement procedures, see [Removing and replacing the cable management arm.](#)

## System components

Hewlett Packard Enterprise continually improves and changes product parts. For complete and current supported spare parts information, see the Hewlett Packard Enterprise PartSurfer website:

<https://www.hpe.com/info/partssurfer>

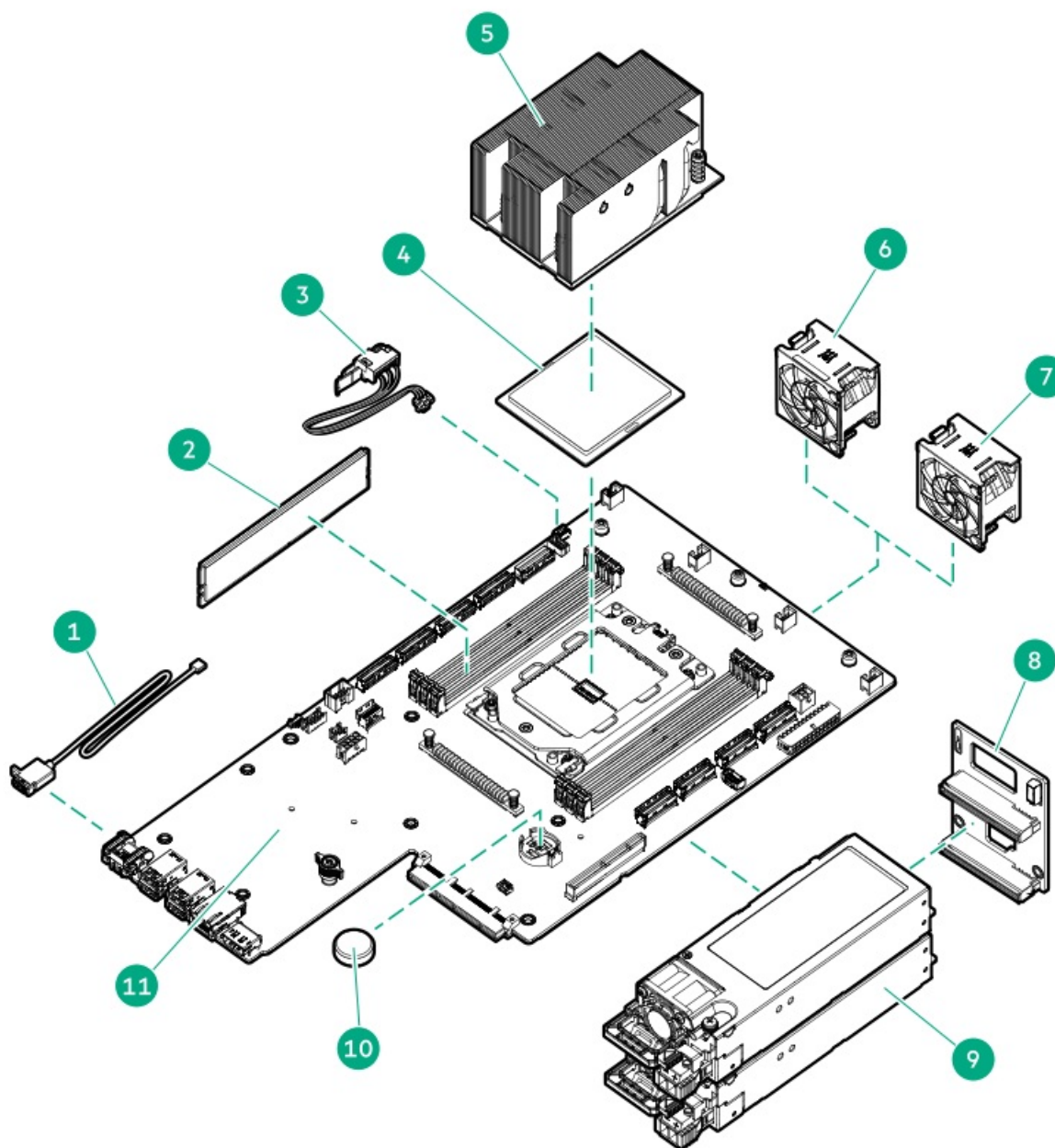

Item	Description
1	<a href="#">iLO service port cable spare part</a>
2	<a href="#">DIMM spare parts</a>
3	<a href="#">Chassis intrusion detection switch spare part</a>
4	<a href="#">Processor spare parts</a>
5	<a href="#">Heatsink spare part</a>
6	<a href="#">High performance fan spare part</a>
7	<a href="#">Standard fan spare part</a>
8	<a href="#">Power distribution board and cable spare parts</a>
9	<a href="#">Power supply spare parts</a>
10	<a href="#">System battery spare part</a>
11	<a href="#">System board spare part</a>

### Subtopics

[Power supply spare parts](#)

[iLO service port cable spare part](#)

[Chassis intrusion detection switch spare part](#)

[Fan spare parts](#)

[DIMM spare parts](#)

[Processor spare parts](#)

[Heatsink spare part](#)

[Power distribution board \(PDB\) and cable spare parts](#)

[System battery spare part](#)

[System board spare part](#)

## Power supply spare parts

[Customer self repair: Mandatory](#)

Description	Spare part number
HPE 700 W Flex Slot Platinum Hot-plug Power Supply	P43064-001
HPE 700 W Flex Slot -48 VDC Hot-plug Low Halogen Power Supply	P40359-001
HPE 1000 W Flex Slot Titanium Hot-plug Power Supply	P59321-001

For more information on the removal and replacement procedures, see [Flexible Slot power supply replacement](#).

## iLO service port cable spare part

[Customer self repair: Mandatory](#)

Description	Spare part number
iLO service port cable	P72576-001

For more information on the removal and replacement procedures, see [Removing and replacing the iLO service port cable](#).

## Chassis intrusion detection switch spare part

Customer self repair: Mandatory

Description	Spare part number
Chassis intrusion detection switch	P52442-001

For more information on the removal and replacement procedures, see [Removing and replacing the chassis intrusion detection switch](#).

## Fan spare parts

Customer self repair: Optional

Description	Spare part number
Standard fan	P72382-001
High performance fan	P72383-001

For more information on the removal and replacement procedures, see [Removing and replacing the fan](#).

## DIMM spare parts

Customer self repair: Mandatory

Description	Spare part number
16 GB, single-rank x8 PC5-4800B-R	P56150-001
32 GB, dual-rank x8 PC5-4800B-R	P56152-001
64 GB, dual-rank x4 PC5-4800B-R	P56153-001
96 GB, dual-rank x4 PC5-4800B-R	P67364-001
128 GB, dual-rank x4 PC5-4800B-R	P71560-001

For more information on the removal and replacement procedures, see [Removing and replacing a DIMM](#).

## Processor spare parts

Customer self repair: Optional

Description	Spare part number
AMD EPYC 8024PN, 2.05 GHz, 8C, 75 W	P72405-001
AMD EPYC 8124PN, 2.00 GHz, 16C, 100 W	P72406-001
AMD EPYC 8224PN, 2.05 GHz, 24C, 115 W	P72407-001
AMD EPYC 8324PN, 2.05 GHz, 32C, 130 W	P72408-001
AMD EPYC 8434PN, 2.00 GHz, 48C, 150 W	P72409-001
AMD EPYC 8534PN, 2.05 GHz, 64C, 175 W	P72410-001

For more information on the removal and replacement procedures, see [Processor replacement](#).

## Heatsink spare part

Customer self repair: Optional

Description	Spare part number
Standard 2U heatsink	P72381-001

For more information on the removal and replacement procedures, see [Removing and replacing a heatsink](#).

## Power distribution board (PDB) and cable spare parts

Customer self repair: Mandatory

Description	Spare part number
Power distribution board	P74768-001
PDB side band cable	P72571-001
System and CPU power cable	P72572-001

For more information on the removal and replacement procedures, see [Removing and replacing the power distribution board](#).

## System battery spare part

Customer self repair: Mandatory

Description	Spare part number
3.0-V lithium battery coin (CR2032)	319603-001

For more information on the removal and replacement procedures, see [System battery replacement](#).

## System board spare part

Customer self repair: Optional

Description	Spare part number
System board	P74760-001

For more information on the removal and replacement procedures, see [System board replacement](#).

## Server options

Hewlett Packard Enterprise continually improves and changes product parts. For complete and current supported spare parts information, see the Hewlett Packard Enterprise PartSurfer website:

<https://www.hpe.com/info/partssurfer>

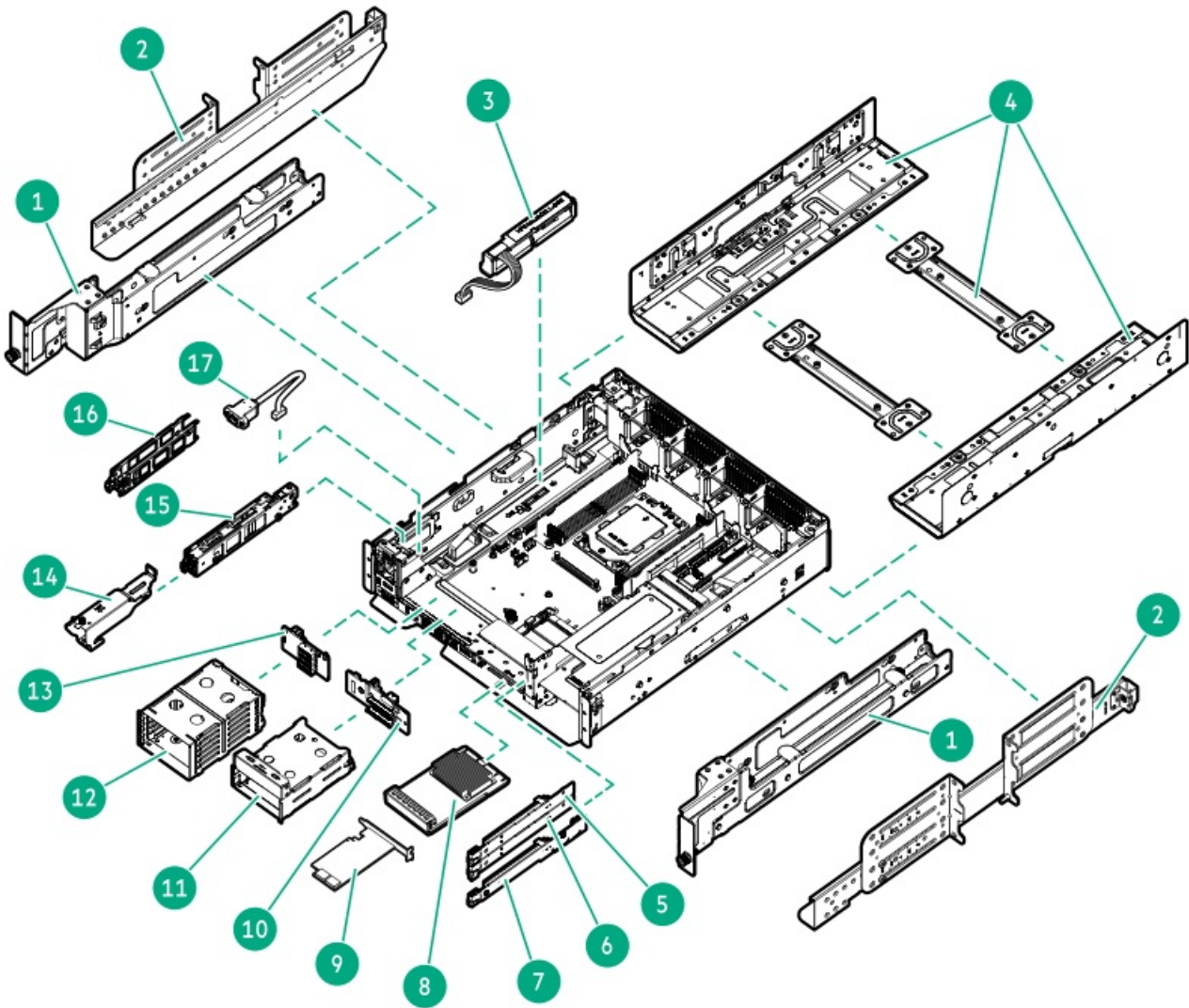

Item	Description
1	<a href="#">Rack mount bracket spare part</a>
2	<a href="#">Two-post rack support bracket spare part</a>
3	<a href="#">Energy pack spare part</a>
4	<a href="#">Wall mount / desktop installation kit spare part</a>
5	<a href="#">Slot 1 stacking riser spare part</a>
6	<a href="#">Slot 2 stacking riser spare part</a>
7	<a href="#">Slot 3 base riser spare part</a>
8	<a href="#">HPE MR type-o storage controller spare part</a>
9	<a href="#">HPE MR type-p storage controller spare parts</a>
10	<a href="#">SFF drive backplane spare part</a>
11	<a href="#">SFF drive cage spare part</a>
12	<a href="#">E3.S drive cage spare part</a>
13	<a href="#">E3.S drive backplane spare part</a>
14	<a href="#">Boot device bracket spare part</a>
15	<a href="#">HPE NS204i-u Boot Device spare parts</a>
16	<a href="#">M.2 SSD carrier spare part</a>
17	<a href="#">RJ45-serial port cable spare part</a>
18	<a href="#">Drive cable spare parts</a> *

\* Not shown

#### Subtopics

[Wall mount / desktop installation kit spare part](#)

[Rack mount bracket spare part](#)

[Two-post rack support bracket spare part](#)

[RJ45-serial port cable spare part](#)

[Energy pack spare part](#)

[Drive backplane spare parts](#)

[Drive cable spare parts](#)

[Drive cage spare parts](#)

[Riser board spare parts](#)

[Storage controller spare parts](#)

[Boot device bracket spare part](#)

[HPE NS204i-u Boot Device spare parts](#)

## Wall mount / desktop installation kit spare part

**Customer self repair: Mandatory**

Description	Spare part number
Wall mount / desktop installation spare kit, includes	P74766-001
<ul style="list-style-type: none"> <li>Left and right side covers</li> <li>Wall mount connecting bracket</li> </ul>	

For more information on the removal and replacement procedures, see:

- [Removing and replacing the side covers](#)
- [Removing and replacing the wall mount connecting brackets](#)

## Rack mount bracket spare part

Customer self repair: Mandatory

Description	Spare part number
-------------	-------------------

Left and right rack mount brackets	P74767-001
------------------------------------	------------

For more information on the removal and replacement procedures, see [Removing and replacing the rack mount brackets](#).

## Two-post rack support bracket spare part

Customer self repair: Mandatory

Description	Spare part number
-------------	-------------------

Left and right two post rack support brackets	P78958-001
---	------------

For more information on the removal and replacement procedures, see [Removing and replacing the two-post rack support brackets](#).

## RJ45-serial port cable spare part

Customer self repair: Mandatory

Description	Spare part number
-------------	-------------------

RJ45-serial port cable	P72577-001
------------------------	------------

For more information on the removal and replacement procedures, see [Removing and replacing the RJ45-serial port cable](#).

## Energy pack spare part

Customer self repair: Mandatory

Description	Spare part number
-------------	-------------------

HPE Smart Storage Battery 96 W, 145 mm cable	878643-001
--	------------

For more information on the removal and replacement procedures, see [Removing and replacing the energy pack](#).

## Drive backplane spare parts

Customer self repair: Mandatory

Description	Spare part number
SFF drive backplane	—
2 SFF 24G x4 U.3 NVMe / SAS / SATA UBM3 BC (stacked)	P39782-001
E3.S drive backplane	—
4 E3.S 32G x4 U.3 NVMe UBM10 EC1	P73067-001

For more information on the removal and replacement procedures, see the following:

- [Removing and replacing the 2 SFF drive backplane](#)
- [Removing and replacing the 4 E3.S drive backplane](#)

## Drive cable spare parts

Customer self repair: Mandatory

Description and cable part number	Spare part number
2 SFF SATA drive cable for system board connection: P57307-001	P61260-001
2 SFF NVMe drive cable for system board connection: P57311-001	P61259-001
2 SFF drive power cable: P70281-001	P72573-001
6 E3.S enablement cable for system board connection: P70286-001	P72578-001
6 E3.S enablement cable from Box 1 to type-p controller: P72524-001	P74005-001
6 E3.S enablement cable from Box 2 to type-p controller: P72525-001	P74006-001
4 E3.S NVMe drive cable for system board connection: P59100-001	P60559-001
6 E3.S drive power Y cable: P70282-001	P72574-001
4 E3.S NVMe drive cable for type-o controller: P72526-001	P74007-001
4 E3.S x4 NVMe drive cable for type-p controller: P51556-001	P58218-001

For more information on the removal and replacement procedures, see [Removing and replacing the 6 E3.S enablement cable on the E3.S drive cage](#).

## Drive cage spare parts

Customer self repair: Mandatory

Description	Spare part number
SFF drive cage	P74761-001
E3.S drive cage	P74762-001

For more information on the removal and replacement procedures, see:

- [Removing and replacing the 2 SFF drive cage](#)
- [Removing and replacing the E3.S drive cage](#)

## Riser board spare parts

Customer self repair: Optional

Description	Spare part number
Slot 1 PCIe5 x16 stacking riser	P60861-001
Slot 2 PCIe5 x16 stacking riser	P60422-001
Slot 3 PCIe5 x16 1U base riser	P59443-001

For more information on the removal and replacement procedures, see:

- [Removing and replacing a stacking riser in the three-slot riser cage](#)
- [Removing and replacing the base riser in the three-slot riser cage](#)

## Storage controller spare parts

Customer self repair: Optional

Description	Spare part number
HPE Gen11 type-o controller	—
HPE MR408i-o Gen11 controller	P58543-001
HPE Gen11 type-p controllers	—
HPE MR216i-p Gen11 controller	P47953-001
HPE MR416i-p Gen11 controller	P47951-001

For more information on the removal and replacement procedures, see:

- [Removing and replacing a type-o storage controller](#)
- [Removing and replacing a type-p storage controller](#)

## Boot device bracket spare part

Customer self repair: Mandatory

Description	Spare part number
Boot device bracket	P74763-001

For more information on the removal and replacement procedures, see [Removing and replacing the boot device bracket](#).

## HPE NS204i-u Boot Device spare parts



### IMPORTANT

For successful RAID 1 configuration, verify that the boot device SSDs have the same model number and firmware version:

- In the iLO web interface, see the Storage page.
- In UEFI System Utilities, see [System Configuration > HPE NS204i Boot Controller > Physical Device Information](#).

Configurations with SSDs from different manufacturers are not supported.

Description	Spare part number
Boot device cage assembly	P51341-001
M.2 SSD carrier	P59777-001
480 GB NVMe RI M.2 SV 2280 SSD	P69616-001
Boot device SlimSAS and power cables <sup>1</sup>	P56479-001

<sup>1</sup> This is a miscellaneous cable spare kit; only the cables listed in this table are used in this server.

For more information on the removal and replacement procedures, see [HPE NS204i-u Boot Device replacement](#).

## Removal and replacement procedures

This chapter provides detailed instructions on how to remove and replace component spare parts.

### Subtopics

[Safety considerations](#)

[Preparation procedures](#)

[Removing and replacing the front bezel assembly](#)

[Front bezel filter replacement](#)

[Removing and replacing a hot-plug SFF/E3.S drive](#)

[Removing and replacing a drive blank](#)

[Removing and replacing an E3.S drive cage filler](#)

[Flexible Slot power supply replacement](#)

[Removing and replacing the side covers](#)

[Removing and replacing the wall mount connecting brackets](#)

[Removing and replacing the cable management arm](#)

[Removing and replacing the rack rails](#)

[Removing and replacing the rack mount brackets](#)

[Removing and replacing the two-post rack support brackets](#)

[Removing and replacing a fan](#)

[Removing and replacing a DIMM](#)

[Removing and replacing the 2 SFF drive cage](#)

[Removing and replacing the E3.S drive cage](#)

[Removing and replacing the 6 E3.S enablement cable on the E3.S drive cage](#)

[Drive backplane replacement](#)

[Expansion card replacement](#)

[Removing and replacing a type-o storage controller](#)

[Riser board replacement](#)

[Removing and replacing the OCP 3.0 NIC](#)

[HPE NS204i-u Boot Device replacement](#)  
[Removing and replacing the iLO service port cable](#)  
[Removing and replacing the RJ45-serial port cable](#)  
[Removing and replacing the energy pack](#)  
[Removing and replacing the chassis intrusion detection switch](#)  
[Heatsink replacement](#)  
[Processor replacement](#)  
[Removing and replacing the power distribution board \(PDB\)](#)  
[System board replacement](#)  
[System battery replacement](#)

## Safety considerations

Before performing service procedures, review all the safety information.

### Subtopics

[Electrostatic discharge](#)  
[Symbols on equipment](#)  
[Rack warnings and cautions](#)  
[Server warnings and cautions](#)

## Electrostatic discharge

Be aware of the precautions you must follow when setting up the system or handling components. A discharge of static electricity from a finger or other conductor may damage system boards or other static-sensitive devices. This type of damage may reduce the life expectancy of the system or component.

To prevent electrostatic damage:

- Avoid hand contact by transporting and storing products in static-safe containers.
- Keep electrostatic-sensitive parts in their containers until they arrive at static-free workstations.
- Place parts on a grounded surface before removing them from their containers.
- Avoid touching pins, leads, or circuitry.
- Always be properly grounded when touching a static-sensitive component or assembly. Use one or more of the following methods when handling or installing electrostatic-sensitive parts:
  - Use a wrist strap connected by a ground cord to a grounded workstation or computer chassis. Wrist straps are flexible straps with a minimum of 1 megohm  $\pm$ 10 percent resistance in the ground cords. To provide proper ground, wear the strap snug against the skin.
  - Use heel straps, toe straps, or boot straps at standing workstations. Wear the straps on both feet when standing on conductive floors or dissipating floor mats.
  - Use conductive field service tools.
  - Use a portable field service kit with a folding static-dissipating work mat.

If you do not have any of the suggested equipment for proper grounding, have an authorized reseller install the part.

For more information on static electricity or assistance with product installation, contact an authorized reseller.

## Symbols on equipment

The following symbols may be placed on equipment to indicate the presence of potentially hazardous conditions:



This symbol in conjunction with any of the following symbols indicates the presence of a potential hazard. The potential for injury exists if warnings are not observed. Consult your documentation for specific details.

該符號與以下任意符號組合使用，指示存在潛在的危險。如果不遵守警告，可能會造成人身傷害。詳細信息請參閱相關文檔。



This symbol indicates the presence of hazardous energy circuits or electric shock hazards. Refer all servicing to qualified personnel.



**WARNING**

To reduce the risk of injury from electric shock hazards, do not open this enclosure. Refer all maintenance, upgrades, and servicing to qualified personnel.

此符號表明存在危險電路或觸電的危險。所有維修工作應由具有相關資格的人員來完成。

警告：為了減少觸電造成人身傷害的危險，請不要打開此外殼。所有維護、升級和維修工作都應由具有相關資格的人員來完成。



This symbol indicates the presence of electric shock hazards. The area contains no user or field-serviceable parts. Do not open for any reason.



**WARNING**

To reduce risk of injury from electric shock hazards, do not open this enclosure.

此符號表明存在觸電的危險。在這一區域內沒有用戶可以現場維修的部件。一定不要打開。警告：為了減少觸電造成人身傷害的危險，請不要打開此外殼。



This symbol on an RJ-45 receptacle indicates a Network Interface Connection.



**WARNING**

To reduce risk of electric shock, fire, or damage to the equipment, do not plug telephone or telecommunications connectors into this receptacle.

RJ-45 插孔上的該符號指示網絡接口連接。

警告：為了減少觸電、火災或設備損壞的危險，不要將電話或電信連接設備插入此插孔。



This symbol indicates the presence of a hot surface or hot component. If this surface is contacted, the potential for injury exists.



**WARNING**

To reduce the risk of injury from a hot component, allow the surface to cool before touching.

此符號表明表面或組件過熱。如果觸摸此表面，可能會造成人身傷害。警告：為了減少因組件過熱而造成人身傷害的危險，應等到表面降溫後再觸摸。



This symbol indicates the presence of a moving fan blade. If the spinning blades are contacted, the potential for injury exists.



**WARNING**

Hazardous moving parts. Keep away from moving fan blades. To reduce the risk of injury from a hot component, allow the surface to cool before touching.

此符號表明存在運動風扇葉片的危險。如果觸摸旋轉葉片，可能會造成人身傷害。警告：危險的運動部件。請遠離運動風扇刀片。為減少被高溫組件燙傷的危險，應在表面冷卻之後再接觸。

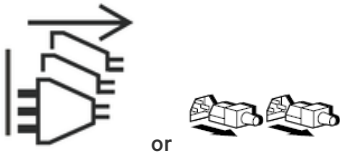

These symbols on power supplies or systems indicate that the equipment is supplied by multiple sources of power.



**WARNING**

To reduce the risk of injury from electric shock, remove all power cords to completely disconnect power from the system.

電源或系統上的這些符號表明設備由多個電源供電。  
警告：為了減少觸電造成人身傷害的危險，應拔下所有電源線插頭，完全斷開系統的電源。



Weight in kg.

Weight in lb.

This symbol indicates that the component exceeds the recommended weight for one individual to handle safely.



**WARNING**

To reduce the risk of personal injury or damage to the equipment, observe local occupational health and safety requirements and guidelines for manual material handling.

此符號表明組件的重量超出了建議值，一個人無法安全取放。  
警告：為了減少人身傷害或設備損壞的危險，應遵守當地有關人工取放物品的職業保健與安全規定及準則。



A discharge of static electricity from a finger or other conductor may damage system boards or other static-sensitive devices. To prevent damage, observe antistatic precautions.

手指或其它導體所釋放的靜電可能損壞主板或其它對靜電敏感的設備。為防止發生損壞，請遵守防靜電預防措施。



These symbols appearing together indicate that the product may have high touch current and that a reliable earth ground must be in place before connecting the equipment.



**WARNING**

Risk of electric shock due to high touch current. Connect to earth before connecting to supply.



This symbol indicates the presence of a laser device in the product that may exceed Class 1 limits. Refer to the product documentation for more information.

此符號表明在可能會超出 1 類限制的產品中存在激光設備。有關詳細信息，請參閱產品文檔。



This symbol indicates the presence of moving parts inside the product that may present a pinch point if improperly contacted.



**WARNING**

Hazardous moving parts. Do not insert any tools or any part of your body into the product while it is operating or in any openings.



This symbol indicates the presence of coin cell battery.



#### **WARNING**

- **INGESTION HAZARD:** This product contains a button cell or coin battery.
- **DEATH** or serious injury can occur if ingested.
- A swallowed button cell or coin battery can cause Internal Chemical Burns in as little as 2 hours.
- **KEEP** new and used batteries **OUT OF REACH** of **CHILDREN**.
- Seek immediate medical attention if a battery is suspected to be swallowed or inserted inside any part of the body.

## Rack warnings and cautions



#### **WARNING**

When all components are removed, the server weighs 11.38 kg (25.09 lb). When all components are installed, the server can weigh up to 15.18 kg (33.47 lb).

Before configuring your rack solution, be sure to check the rack manufacturer weight limits and specifications. Failure to do so can result in physical injury or damage to the equipment and the facility.



#### **WARNING**

The server is heavy. To reduce the risk of personal injury or damage to the equipment, do the following:

- Observe local occupational health and safety requirements and guidelines for manual material handling.
- Get help to lift and stabilize the product during installation or removal, especially when the product is not fastened to the rails. The server weighs more than 11.38 kg (25.09 lb), so at least two people must lift the server into the rack together. An additional person may be required to help align the server if the server is installed higher than chest level.
- Use caution when installing the server in or removing the server from the rack.
- Adequately stabilized the rack before extending a component outside the rack. Extend only one component at a time. A rack may become unstable if more than one component is extended.
- Do not stack anything on top of rail-mounted component or use it as a work surface when extended from the rack.



#### **WARNING**

To reduce the risk of personal injury or damage to the equipment, observe the following precautions:

- The leveling jacks are extended to the floor.
- The full weight of the rack rests on the leveling jacks.
- The stabilizing feet are attached to the rack if it is a single-rack installation.
- The racks are coupled together in multiple-rack installations.

**WARNING**

To reduce the risk of personal injury or equipment damage when unloading a rack:

- At least two people are needed to safely unload the rack from the pallet. An empty 42U rack can weigh as much as 115 kg (253 lb), can stand more than 2.1 m (7 ft) tall, and might become unstable when being moved on its casters.
- Never stand in front of the rack when it is rolling down the ramp from the pallet. Always handle the rack from both sides.

**CAUTION**

Always plan the rack installation so that the heaviest item is on the bottom of the rack. Install the heaviest item first, and continue to populate the rack from the bottom to the top.

**CAUTION**

Before installing the server in a rack, be sure to properly scope the limitations of the rack. Before proceeding with the installation, consider the following:

- You must fully understand the static and dynamic load carrying capacity of the rack and be sure that it can accommodate the weight of the server.
- Be sure sufficient clearance exists for cabling, installation and removal of the server, and movement of the rack doors.

## Server warnings and cautions

**WARNING**

To reduce the risk of personal injury, electric shock, or damage to the equipment, disconnect the power cord to remove power from the server. Pressing the Power On/Standby button does not shut off system power completely. Portions of the power supply and some internal circuitry remain active until AC power is removed.

**WARNING**

To reduce the risk of personal injury from hot surfaces, allow the drives and the internal system components to cool before touching them.

**WARNING**

To reduce the risk of fire or burns after removing the energy pack:

- Do not disassemble, crush, or puncture the energy pack.
- Do not short external contacts.
- Do not dispose of the energy pack in fire or water.
- Do not expose the energy pack to low air pressure as it might lead to explosion or leakage of flammable liquid or gas.
- Do not expose the energy pack to temperatures higher than 60°C (140°F).

After power is disconnected, battery voltage might still be present for 1s to 160s.



#### CAUTION

Protect the server from power fluctuations and temporary interruptions with a regulating UPS. This device protects the hardware from damage caused by power surges and voltage spikes and keeps the server in operation during a power failure.



#### CAUTION

To prevent damage to electrical components, properly ground the server before beginning any installation, removal, or replacement procedure. Improper grounding can cause electrostatic discharge.



#### CAUTION

To avoid data loss, Hewlett Packard Enterprise recommends that you back up all server data before installing or removing a hardware option, or performing a server maintenance or troubleshooting procedure.



#### CAUTION

Do not operate the server for long periods with the access panel open or removed. Operating the server in this manner results in improper airflow and improper cooling that can lead to thermal damage.

## Preparation procedures

### Prerequisites

Before powering down the server for an upgrade, maintenance, or service procedure, do the following:

- Perform a backup of critical server data.
- Review the Component touchpoints.

### About this task

To access components and perform certain upgrade, maintenance, or service procedure, you must perform one or more of the procedures described in this section.

#### Subtopics

[Server data backup](#)

[Remove the front bezel](#)

[Power down the server](#)

[Open the cable management arm](#)

[Extend the server from the rack](#)

[Remove the server from a four-post rack](#)

[Remove the server from a two-post rack](#)

[Remove the access panel](#)

[Remove the air baffle](#)

[Remove the three-slot riser cage](#)

[Remove the drive base cage with the SFF/E3.S drive cage installed](#)

[Power up the server](#)

## Server data backup

To avoid data loss, make sure to back up all server data before installing or removing a hardware option, performing a server maintenance, or a troubleshooting procedure.

Server data in this context refers to information that may be required to return the system to a normal operating environment after completing a hardware maintenance or troubleshooting procedure. This information may include:

- User data files
- User account names and passwords
- Application settings and passwords
- Component drivers and firmware
- TPM recovery key/password
- BIOS configuration settings—Use the backup and restore function in UEFI System Utilities. For more information, see the UEFI user guide (<https://www.hpe.com/support/hpeuefisystemutilities-quicklinks>).
  - Custom default system settings
  - Security passwords including those required for power-on and BIOS admin access, persistent memory, and Server Configuration Lock (for HPE Trusted Supply Chain servers)
  - Server serial number and the product ID
- iLO-related data—Use the iLO backup and restore function. For more information, see the iLO user guide (<https://www.hpe.com/support/hpeilodocs-quicklinks>).
  - iLO license
  - Customer iLO user name, password, and DNS name
  - iLO configuration settings

## Remove the front bezel

### Prerequisites

The server has the FIO front bezel and its brackets (option kit: P72582-B21) installed.

### About this task

If you are using the iLO virtual power button to power the server on/off, you do not need to remove the front bezel.

### Procedure

1. If installed, remove the Kensington security lock.

For more information, see the lock documentation.

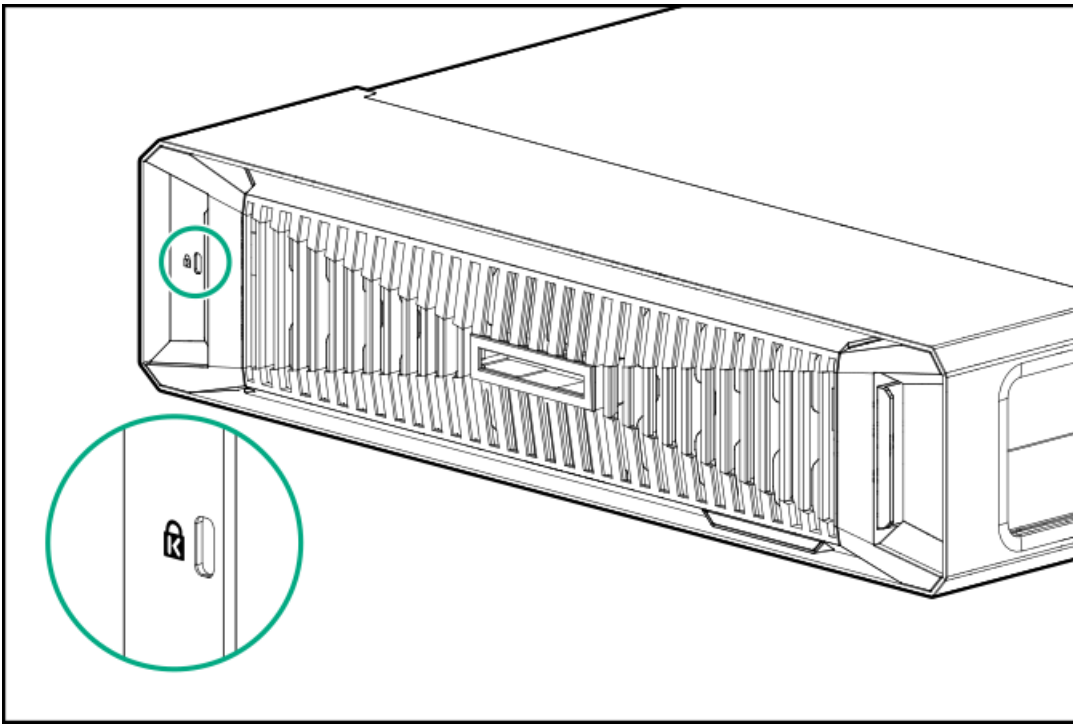

2. Press and hold the bezel release latches, and then slide out the bezel.

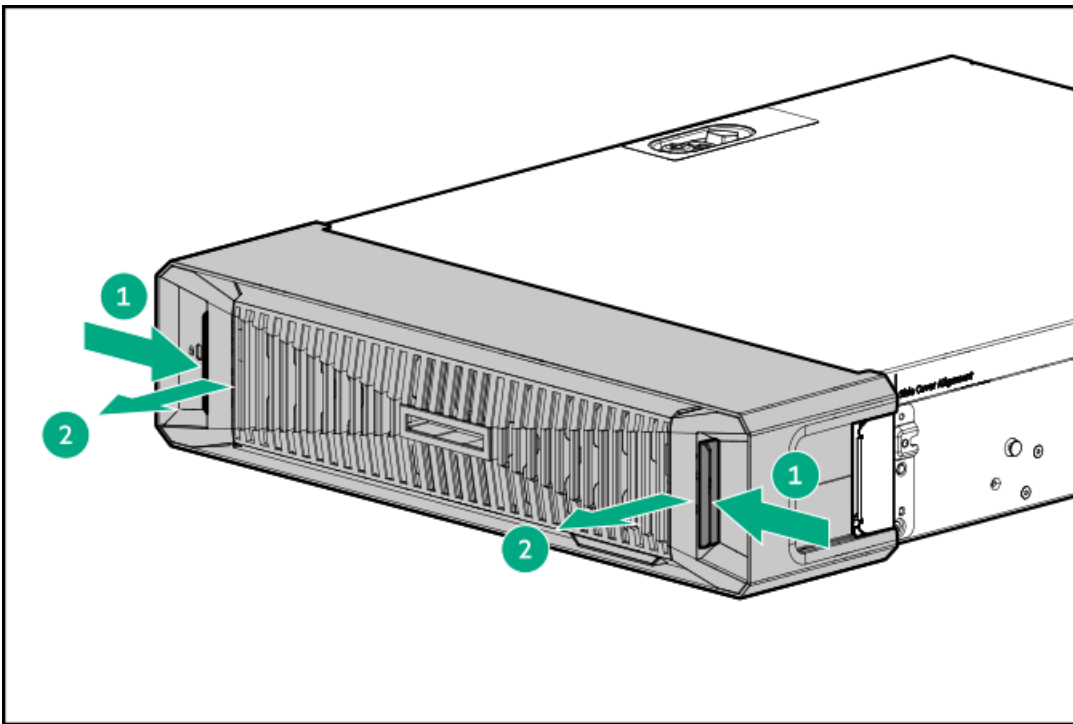

## Power down the server

Before powering down the server for any upgrade or maintenance procedures, perform a backup of critical server data and programs.



### IMPORTANT

When the server is in standby mode, auxiliary power is still being provided to the system.

To power down the server, use one of the following methods:

- Press and release the Power On/Standby button.  
This method activates a controlled shutdown of applications and the OS before the server enters standby mode. It can also activate a shutdown behavior governed by an OS configuration or policy.
- Press and hold the Power On/Standby button for more than 4 seconds to force the server to enter standby mode.  
This method forces the server to enter standby mode without properly exiting applications and the OS. If an application stops responding, you can use this method to force a shutdown.
- Use a virtual power button selection through iLO 6.  
This method initiates a controlled remote shutdown of applications and the OS before the server enters standby mode.

Before proceeding, verify that the server is in standby mode by observing that the system power LED is amber.

## Open the cable management arm

### Procedure

1. Press and hold the blue **PUSH** button on the retention bracket.
2. Swing the arm away from the rear panel.

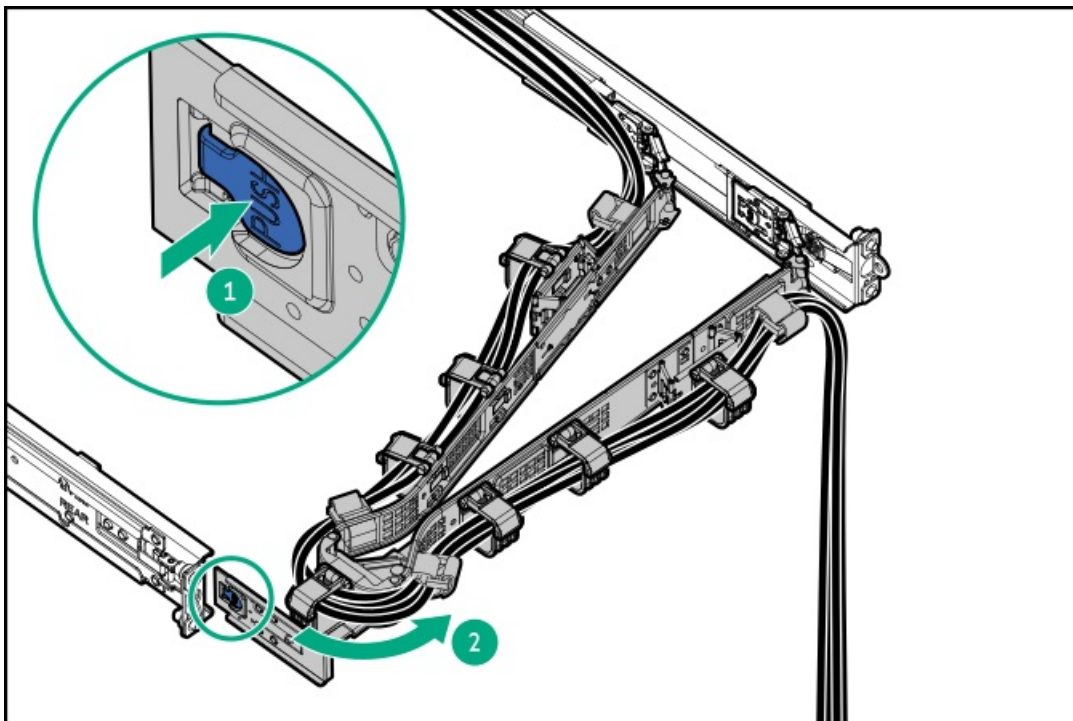

## Extend the server from the rack

### Prerequisites

- Before you perform this procedure, review the [Rack warnings and cautions](#).
- T-25 Torx screwdriver—This tool is required if the shipping screws located on the optional wall mount brackets are secured.

### Procedure

1. If needed, loosen the shipping screws, and then use the rack mount brackets to slide the server out of the rack until the rail-release latches are engaged.

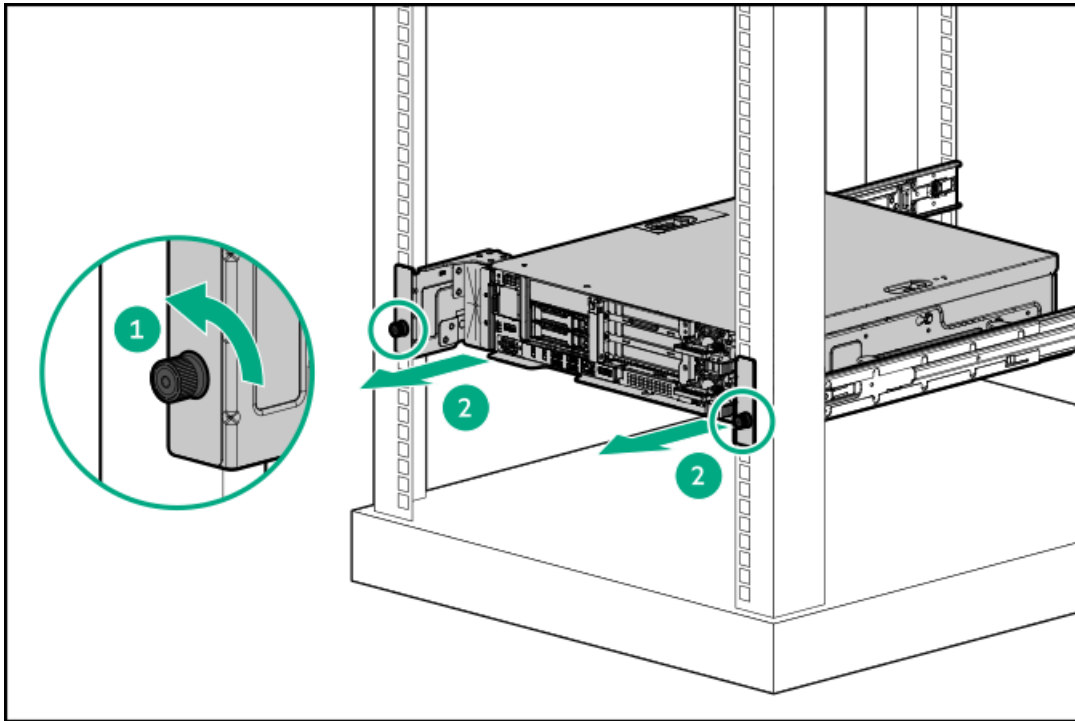

2.  **WARNING**

To reduce the risk of personal injury, be careful when pressing the server rail-release latches. The inner rails could pinch your fingers.

Press and hold the rear-end rail-release latches, and then slide the server out of the rack until it is fully extended.

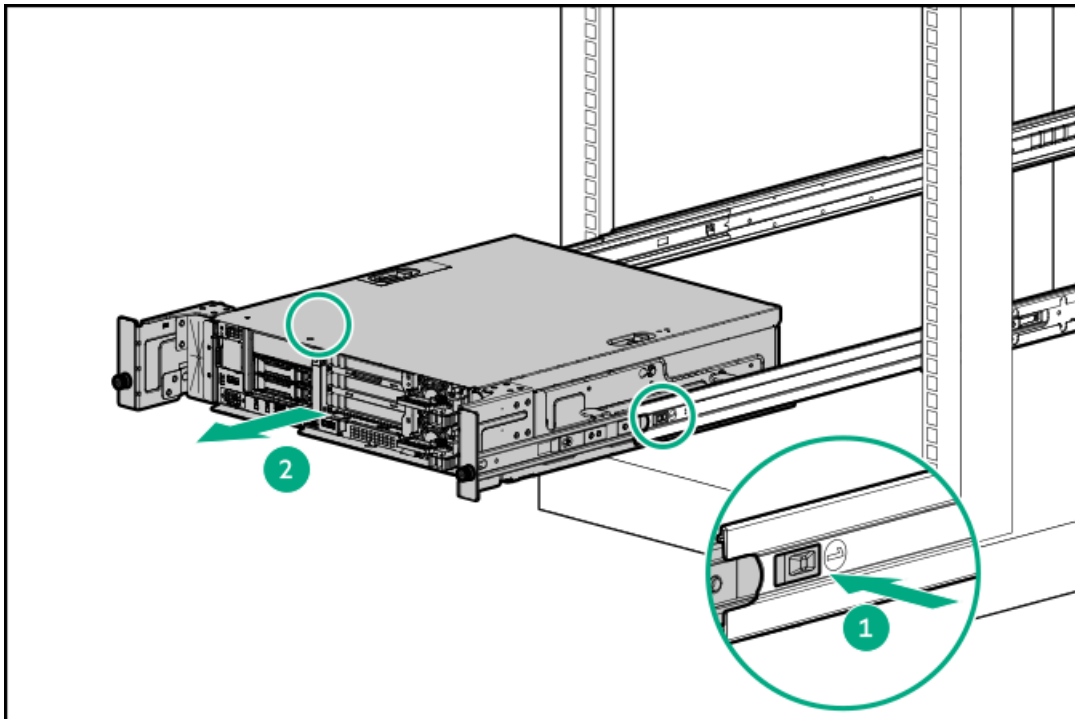

## Remove the server from a four-post rack

### Prerequisites

-  **IMPORTANT**  
Get help to lift and stabilize the server during removal from the rack. **If the server is installed higher than chest level, additional two people might be required to help remove the server:** One person to support the server weight, and the other two to slide the server out of the rack.
- Before you perform this procedure, review the:
  - [Rack warnings and cautions](#)
  - [Server warnings and cautions](#)
- A fully populated server is heavy. Hewlett Packard Enterprise recommends removing the external chassis components before removing the server from the rack.

### About this task

#### Procedure

1. If installed, [remove the front bezel](#).
2. [Power down the server](#).
3. If installed, [open the cable management arm](#).
4. Remove all power:
  - a. Disconnect each power cord from the power source.
  - b. Disconnect each power cord from the server.
5. Disconnect all peripheral cables from the server.
6. Release the peripheral cables and power cords from the rack mount brackets.



#### **WARNING**

To reduce the risk of personal injury or equipment damage, be sure that the rack is adequately stabilized before extending a component from the rack.

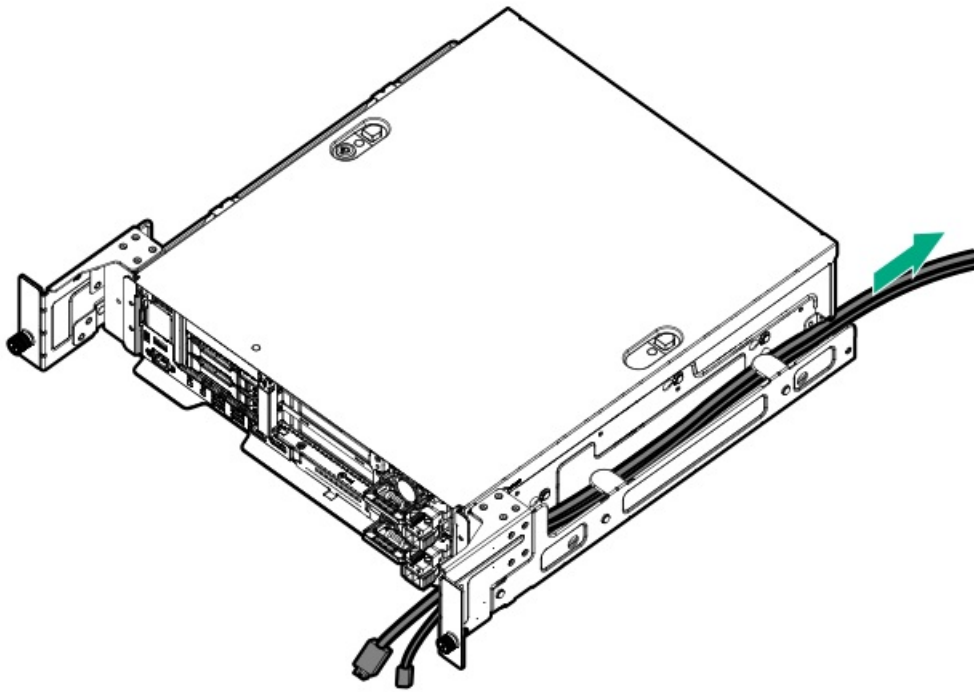

7. Extend the server from the rack.

8.  **WARNING**

To reduce the risk of personal injury, be careful when pressing the server rail-release latches. The inner rails could pinch your fingers.

Remove the server from the rack:

- a. Press and hold the protruding surface of the sliding rails.
- b. Remove the server from the rack.

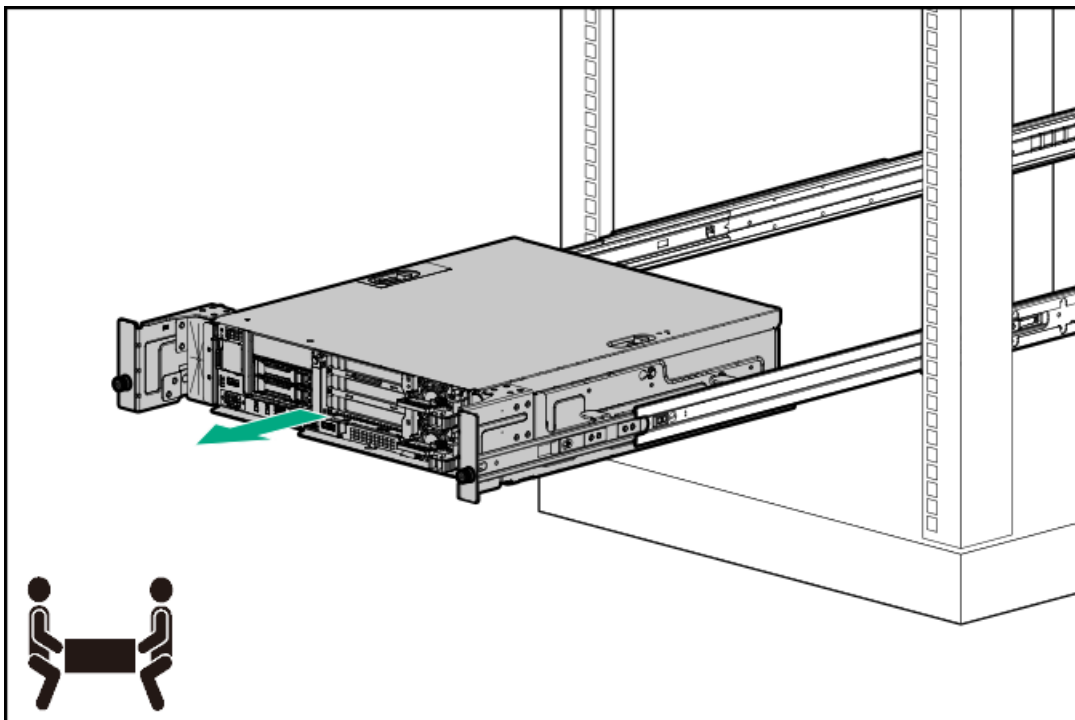

9. Place the server on a flat, level work surface.

# Remove the server from a two-post rack

## Prerequisites

-  **IMPORTANT**  
Get help to lift and stabilize the server during removal from the rack. **If the server is installed higher than chest level, additional two people might be required to help remove the server:** One person to support the server weight, and the other two to slide the server out of the rack.
- Before you perform this procedure, review the:
  - [Rack warnings and cautions](#)
  - [Server warnings and cautions](#)
- A fully populated server is heavy. Hewlett Packard Enterprise recommends removing the external chassis components before removing the server from the rack.

## Procedure

1. If installed, [remove the front bezel](#).
2. [Power down the server](#).
3. If installed, [release the cable management arm](#).
4. Remove all power:
  - a. Disconnect each power cord from the power source.
  - b. Disconnect each power cord from the server.
5. Disconnect all peripheral cables from the server.



### WARNING

To reduce the risk of personal injury or equipment damage, be sure that the rack is adequately stabilized before extending a component from the rack.

6. Release the peripheral cables and power cords from the rack mount brackets.

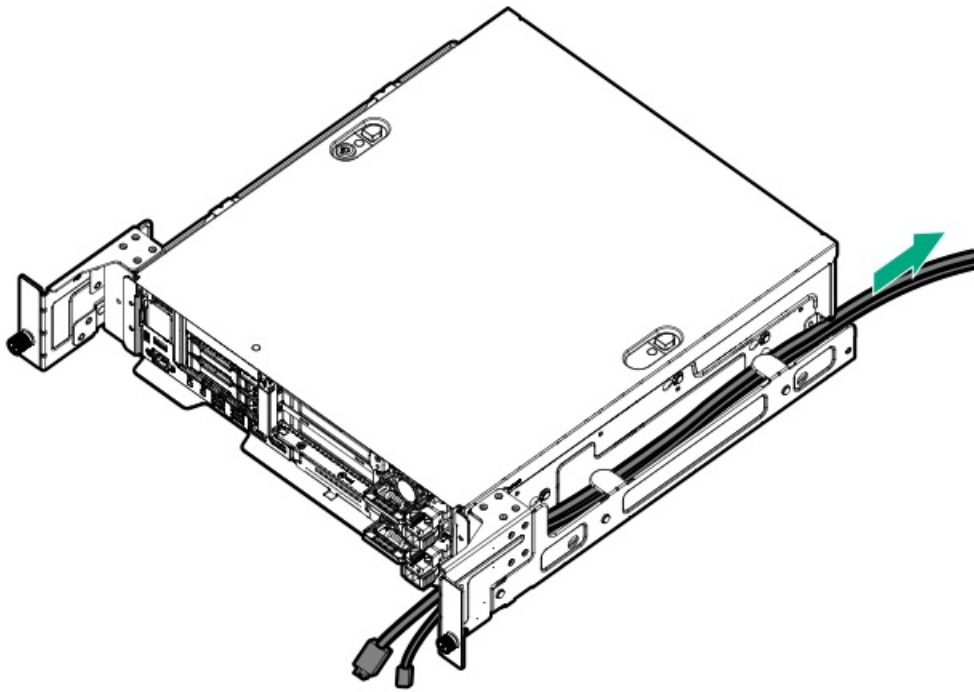

7. If needed, loosen the ear screws of the rack mount brackets, and then use the rack mount brackets to slide the server out of the rack.

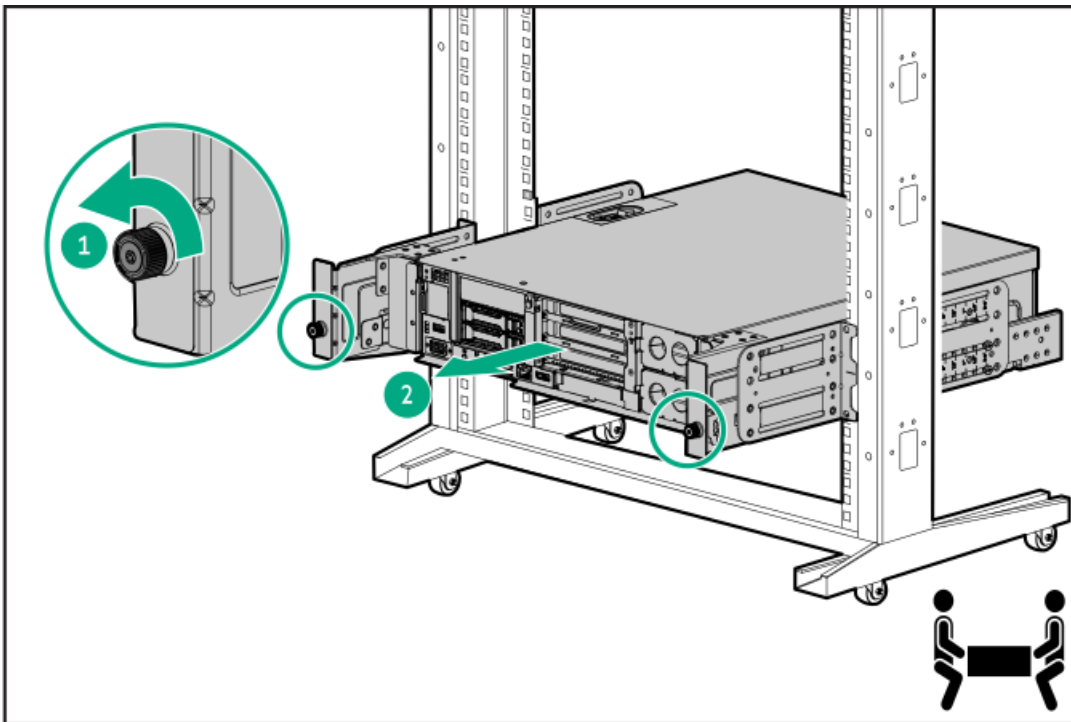

8. Remove the server from the two-post rack support brackets.

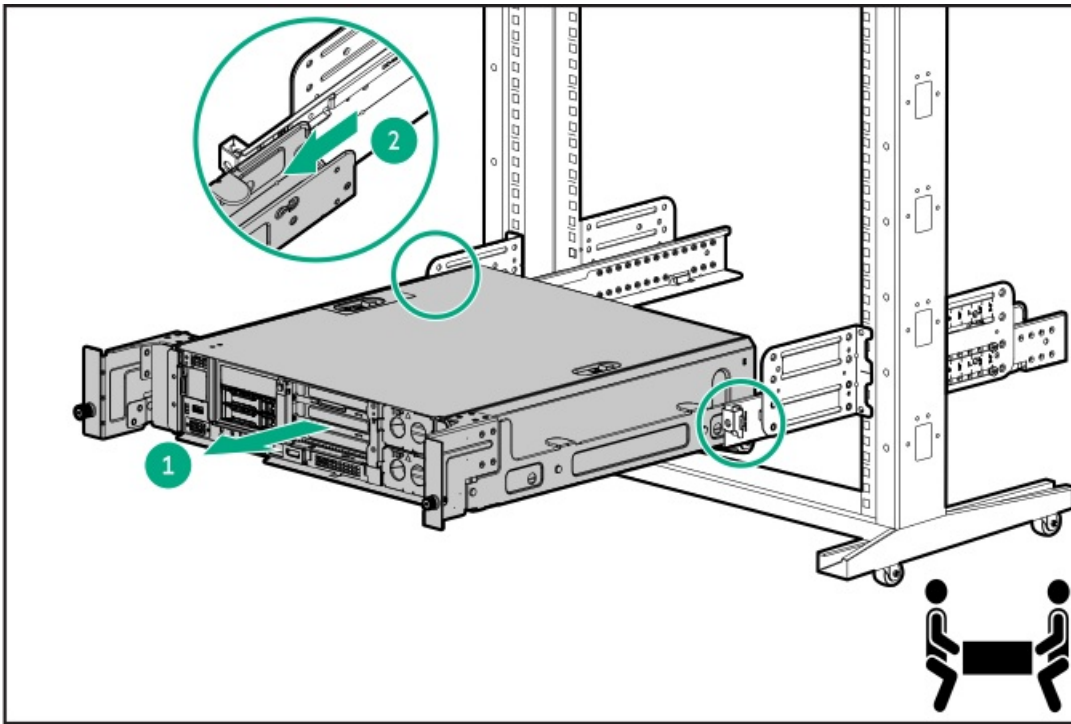

9. Place the server on a flat, level work surface.

## Remove the access panel

### About this task



#### WARNING

To reduce the risk of personal injury from hot surfaces, allow the drives and the internal system components to cool before touching them.



#### CAUTION

To prevent damage to electrical components, properly ground the server before beginning any installation, removal, or replacement procedure. Improper grounding can cause electrostatic discharge.



#### CAUTION

To maintain proper system cooling, do not operate the server for long period with the access panel open or removed. Operating the server in this manner results in an improper system airflow. For internal hot-plug component procedures, complete the procedure within 60 seconds. Failure to do so can cause the system temperature to increase and trip the safety threshold. When this happens:

- The health LED flashes amber.
- The operating system gracefully shuts down.

### Procedure

1. If installed, remove the front bezel.
2. Power down the server.
3. Remove all power:

- a. Disconnect each power cord from the power source.
- b. Disconnect each power cord from the server.
4. Disconnect all peripheral cables from the server.
5. Remove the server from the rack:
  - [Remove the server from a four-post rack.](#)
  - [Remove the server from a two-post rack.](#)
6. Place the server on a flat, level work surface.
7. Remove the access panel:
  - a. If needed, unlock the access panel.
  - b. To disengage the access panel from the chassis, press and hold the two release buttons and slide the access panel to the rear of the chassis.
  - c. Lift the access panel.

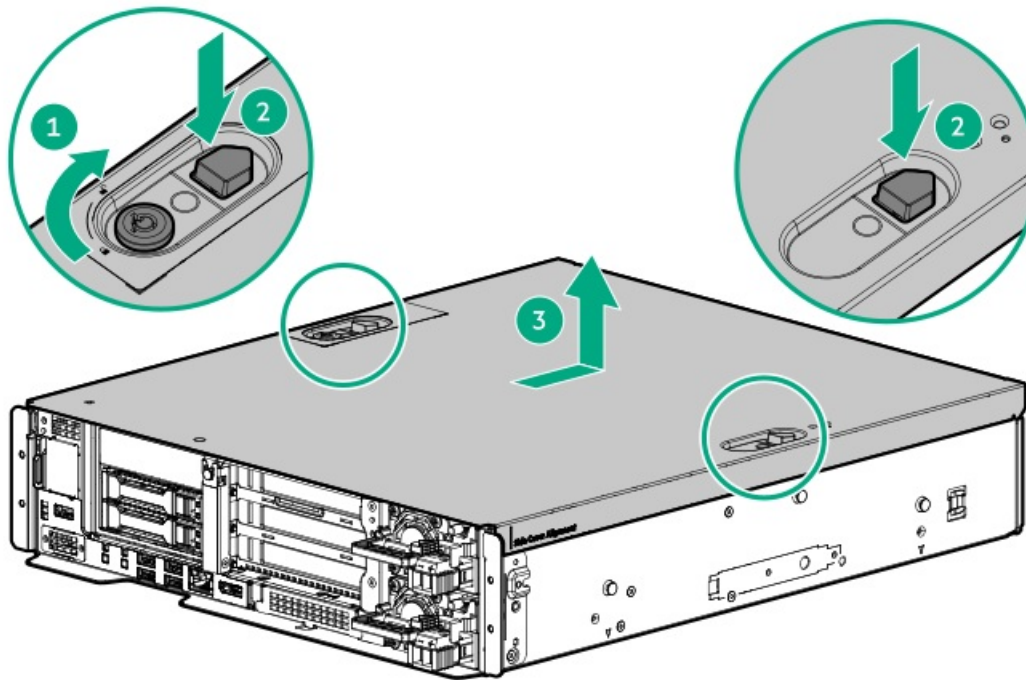

## Remove the air baffle

### About this task



#### CAUTION

For proper cooling, do not operate the server without the access panel, baffles, expansion slot covers, or blanks installed. If the server supports hot-plug components, minimize the amount of time the access panel is open.

### Procedure

1. If installed, [remove the front bezel.](#)

2. Power down the server.
3. Remove all power:
  - a. Disconnect each power cord from the power source.
  - b. Disconnect each power cord from the server.
4. Disconnect all peripheral cables from the server.
5. Remove the server from the rack.
6. Place the server on a flat, level work surface.
7. Remove the access panel.
8. Use the blue finger hooks to lift the air baffle away from the chassis.

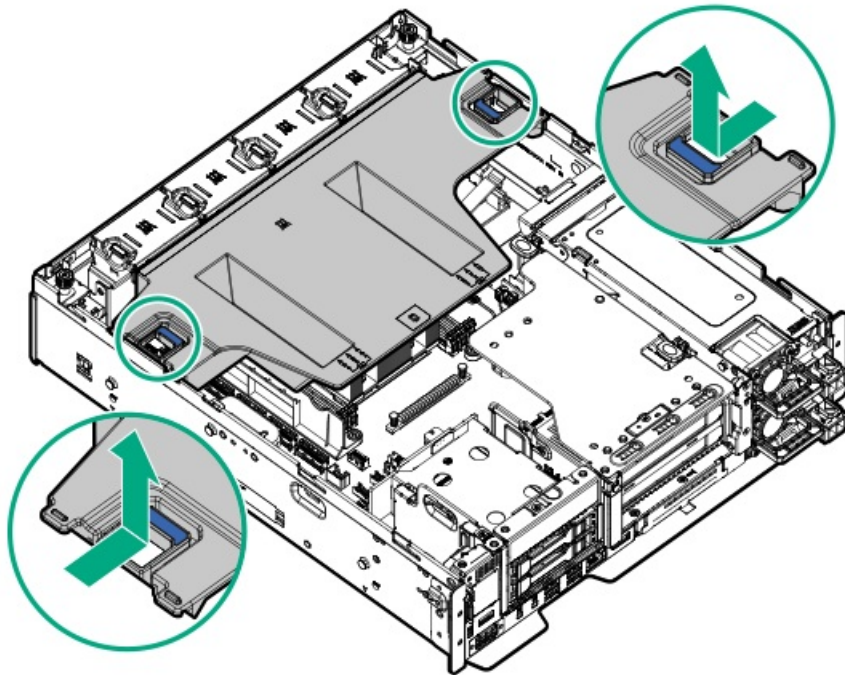

## Remove the three-slot riser cage

### About this task



#### WARNING

To reduce the risk of personal injury from hot surfaces, allow the drives and the internal system components to cool before touching them.



#### CAUTION

A discharge of static electricity from a finger or other conductor might damage system boards or other static-sensitive devices. To prevent damage, observe antistatic precautions.

### Procedure

1. If installed, remove the front bezel.
2. Power down the server.

3. Remove all power:
  - a. Disconnect each power cord from the power source.
  - b. Disconnect each power cord from the server.
4. Disconnect all peripheral cables from the server.
5. Remove the server from the rack.
6. Place the server on a flat, level work surface.
7. Remove the access panel.
8. Remove the air baffle.
9. If an expansion card with internal cables is installed on the riser, disconnect the cables from the card.
10. If stacking risers are installed in PCIe slot 1-2, disconnect the stacking riser cables from the system board.
11. Remove the three-slot riser cage:
  - a. Release the half-turn spring latches.
  - b. Use the blue touchpoints on both sides to lift the riser cage off the system board.

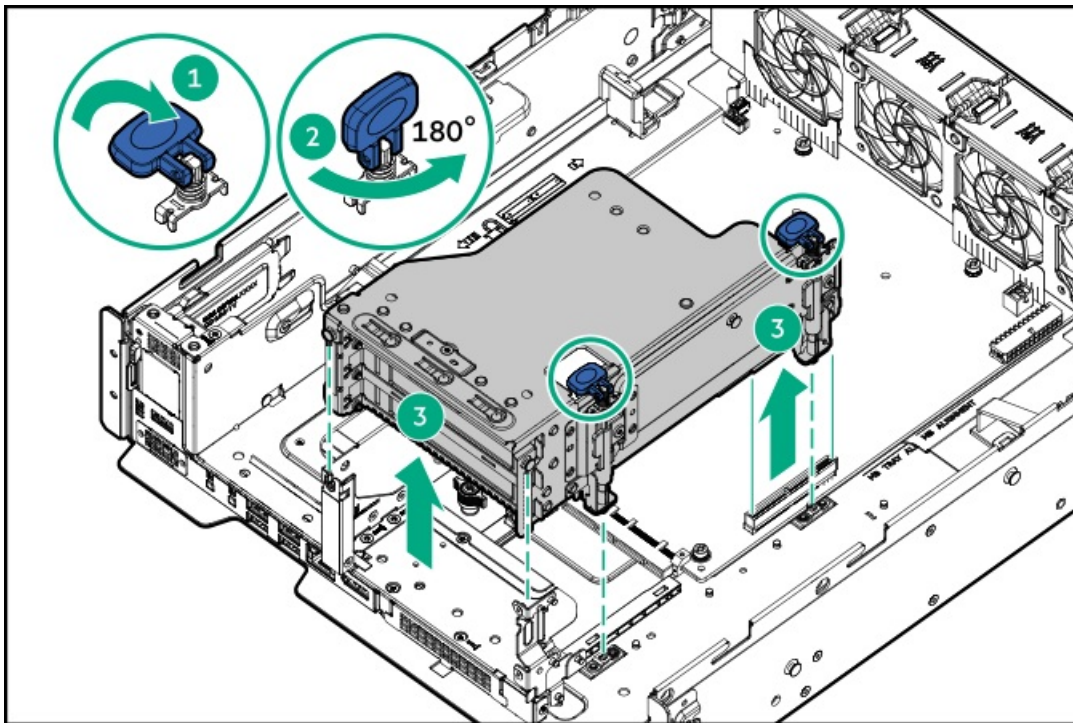

## Remove the drive base cage with the SFF/E3.S drive cage installed

### Prerequisites

Before you perform this procedure, make sure that you have the following items available:

- T-10 Torx screwdriver
- Small slotted screwdriver—This tool is required only if the E3.S drive cage fillers are to be removed.

### About this task



### CAUTION

A discharge of static electricity from a finger or other conductor might damage system boards or other static-sensitive devices. To prevent damage, observe [antistatic precautions](#).



### CAUTION

To prevent improper cooling and thermal damage, do not operate the server unless all bays are populated with either a component or a blank.

## Procedure

1. If installed, [remove the front bezel](#).
2. [Power down the server](#).
3. Remove all power:
  - a. Disconnect each power cord from the power source.
  - b. Disconnect each power cord from the server.
4. Disconnect all peripheral cables from the server.
5. [Remove the server from the rack](#).
6. Place the server on a flat, level work surface.
7. [Remove the access panel](#).
8. [Remove the air baffle](#).
9. If installed, remove the bezel brackets.

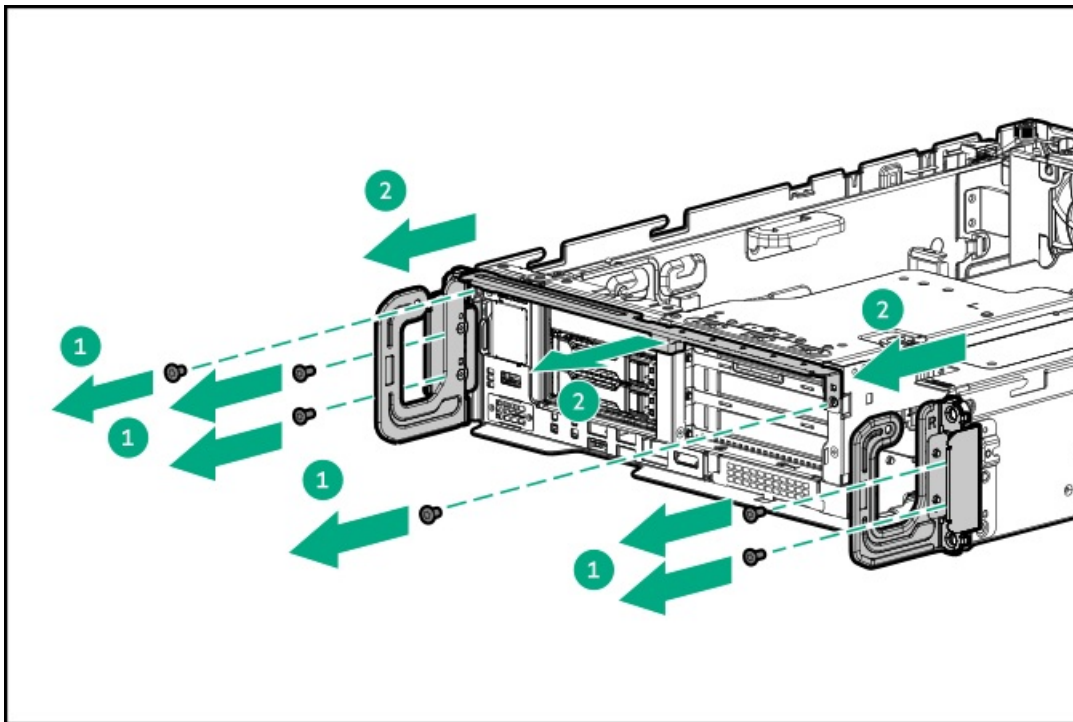

10. [Remove the three-slot riser cage](#).
11. Disconnect the [drive power and signal cables](#) from the drive backplane.
12. Remove the drive base cage:
  - a. Remove the drive base cage screws.

b. Slide the cage toward the front panel, and then lift it out of the chassis.

- SFF drive configuration

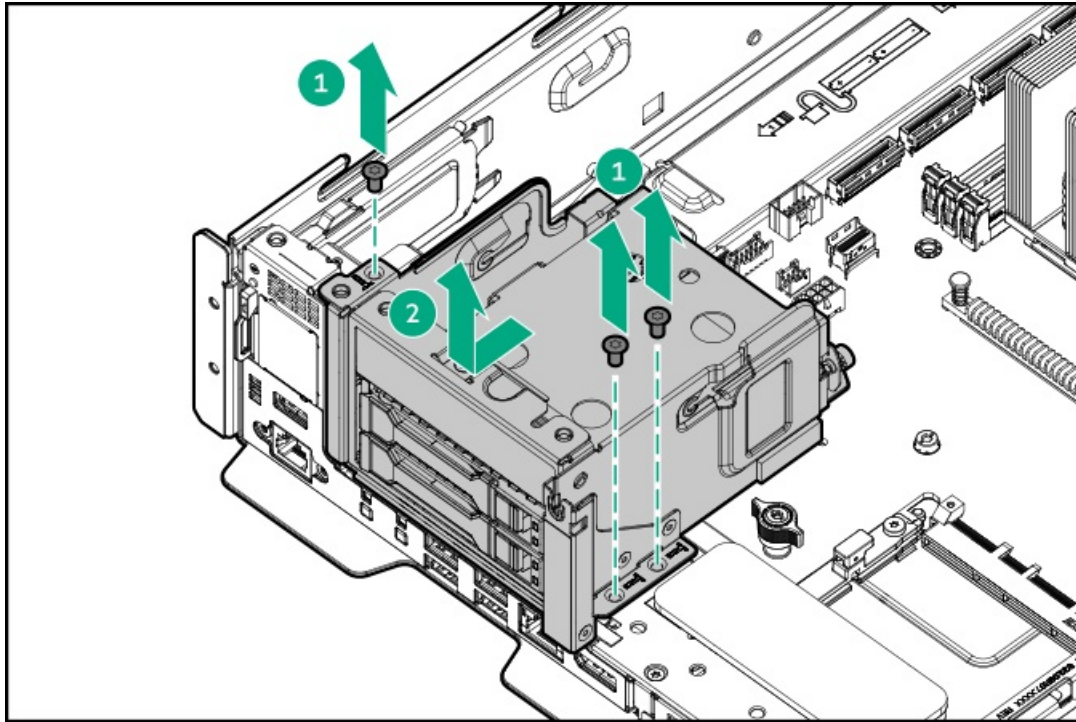

- E3.S drive configuration

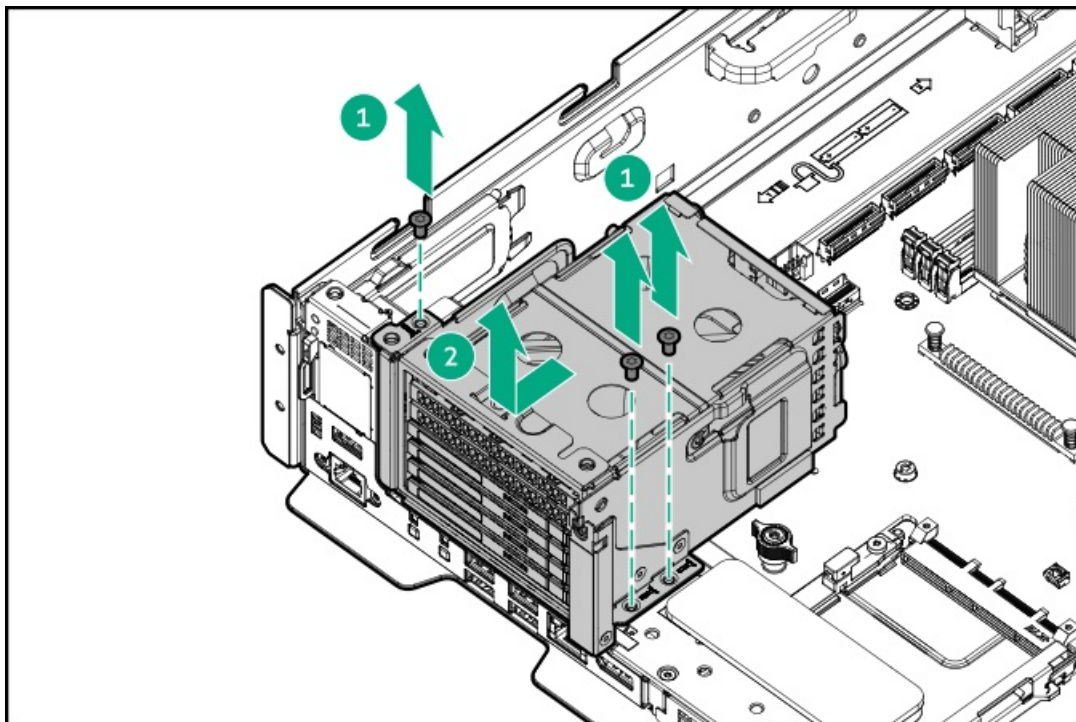

13. Remove all drives.

- SFF drive



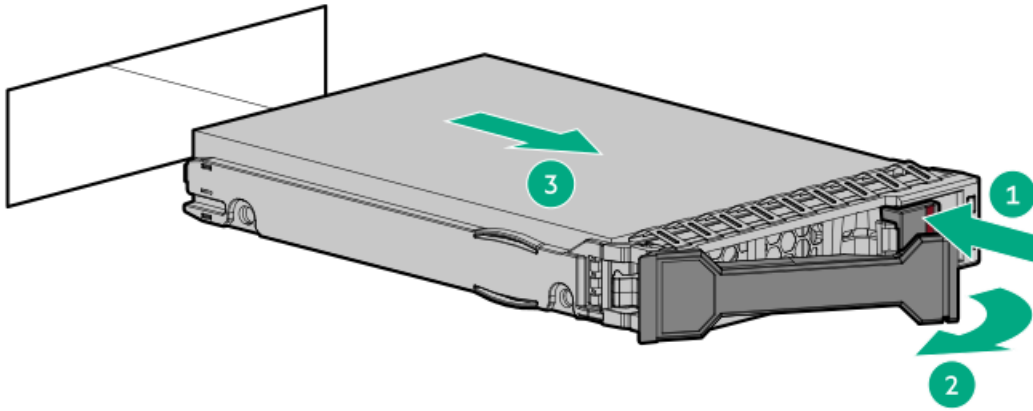

- E3.S drive

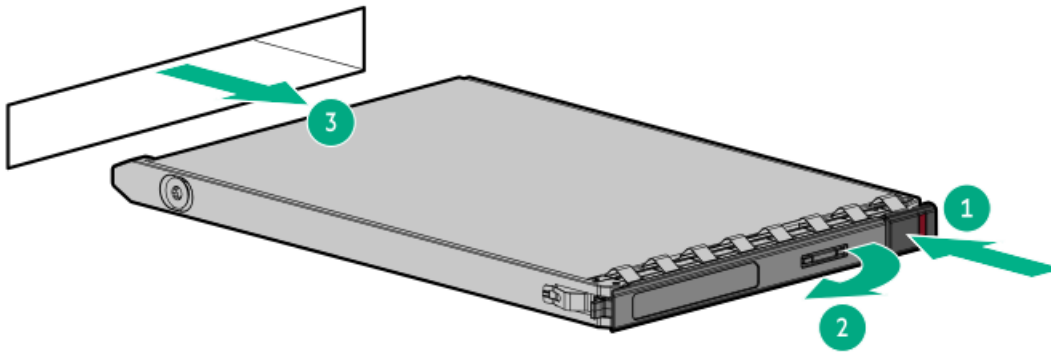

- E3.S drive cage filler for the 4 E3.S drive configuration.

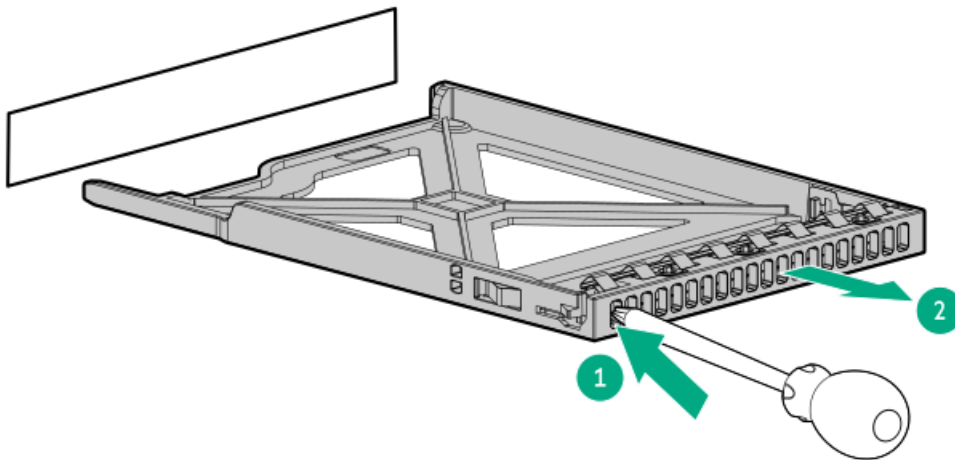

## Power up the server

### Procedure

- Press the Power On/Standby button.
- Use the virtual power button through iLO 6.

## Removing and replacing the front bezel assembly

### Procedure

1. If installed, remove the Kensington security lock.

For more information, see the lock documentation.

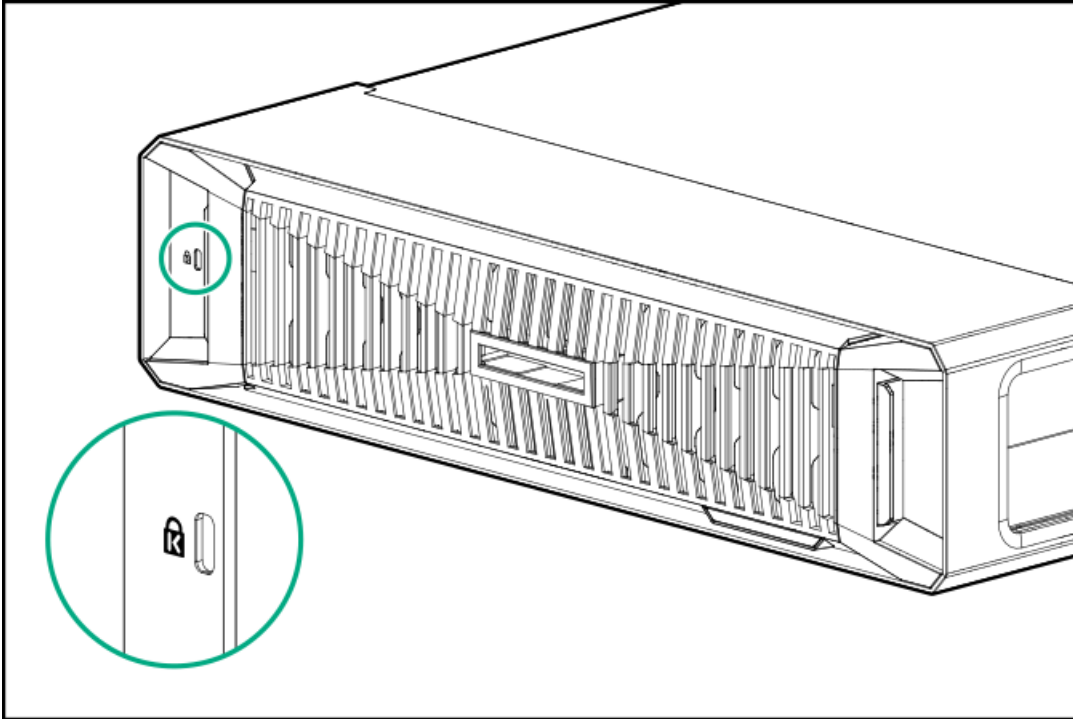

2. Press and hold the bezel release latch, and then slide the bezel out.

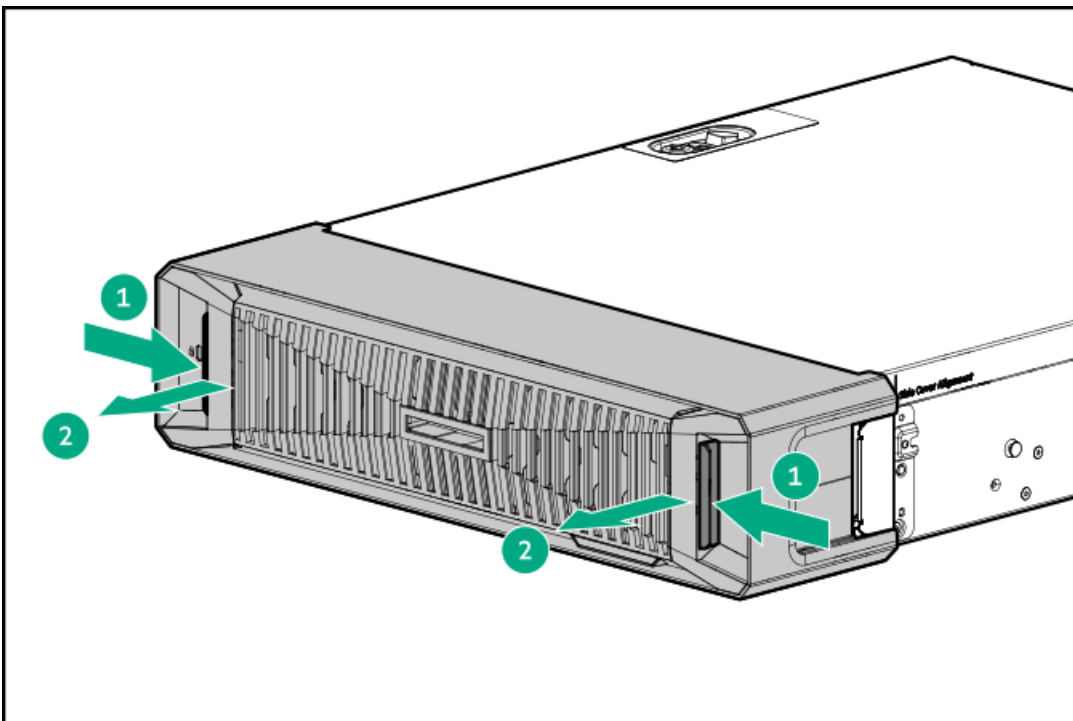

### Removing the front bezel brackets

3. Remove the brackets:

a. Remove the bezel bracket.

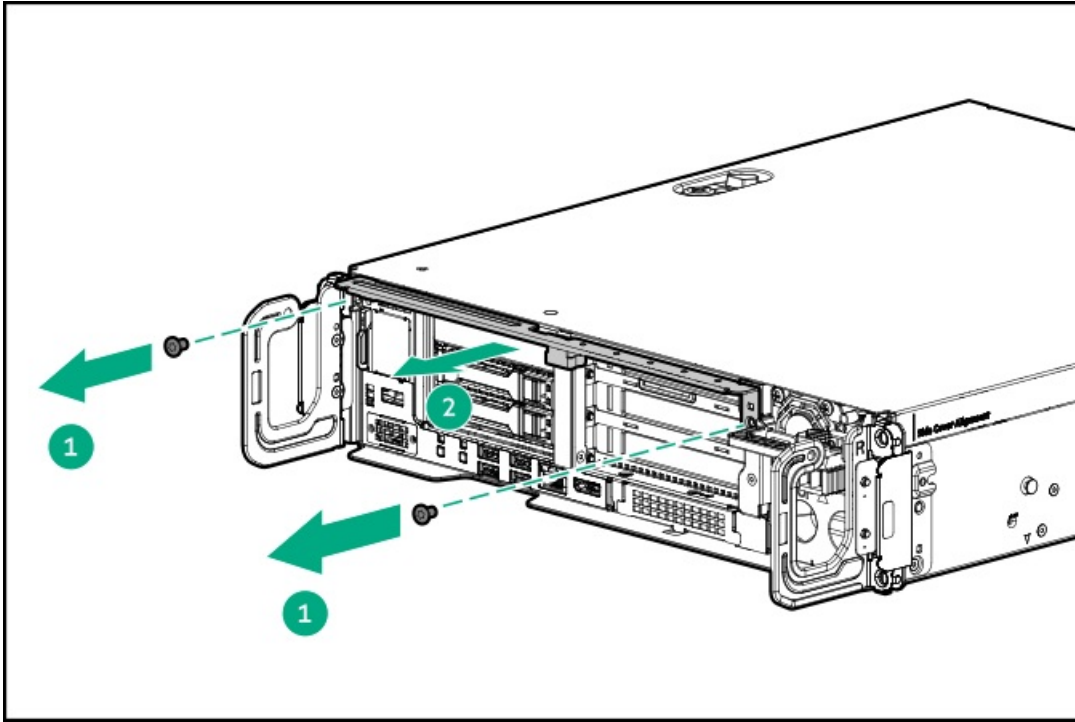

b. Remove the cabling brackets.

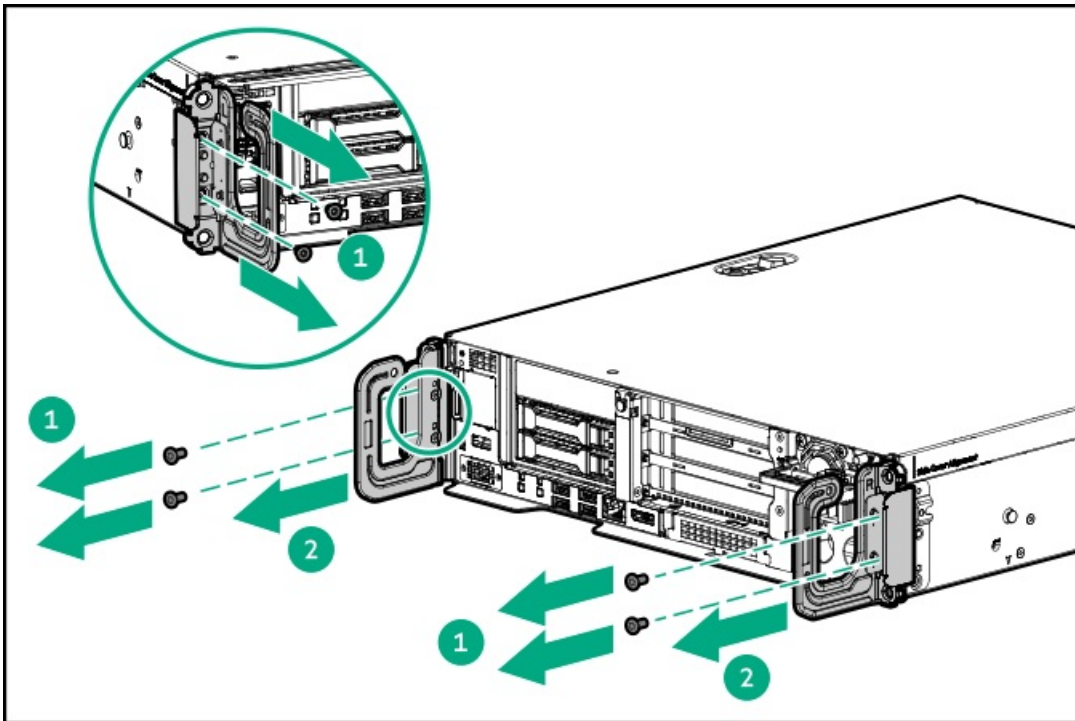

## Results

The removal procedure is complete. To replace the component, reverse this procedure.

## Front bezel filter replacement

### Subtopics



## Front bezel filter maintenance guidelines

To ensure optimal filter performance, observe the following guidelines for the storage, service, and replacement of the front bezel filters.

### Storage

- Avoid storing the air filters in a high temperature and high humidity environment. The optimal storage location is one that is cool, dry, and sheltered from direct sunlight.
- Do not expose the filters to cleaning solvents and sulfates, for example, cleaning agents and exhaust. The chemicals can cause filter degradation. The decrease in filter service life depends on the degree of deviation from the optimal storage and operating environment.
- Purchase economic quantities of the filter and keep enough inventories lasting just a few months. Storing filters for several months or years at a time is not recommended.

### Service and replacement

- Regularly inspect the bezel filter. Replace the filter if it looks clogged or is too dirty. The filter is single-use and should be replaced when necessary. Cleaning the filter can risk undermining the integrity of the filter media, and is not recommended.
- HPE recommends changing the filter at least every three to six months.
- For telecommunication operators and service providers, the governing NEBS standard requires that equipment air filters be replaced following the guideline and recommendation of the manufacturer.

NEBS GR-63-CORE, environmental criteria of network equipment, includes a requirement that "Equipment fan filters shall be single use and not the types that require cleaning."

## Removing and replacing the front bezel filter

### Prerequisites

Before you perform this procedure, review the [Front bezel filter maintenance guidelines](#).

### About this task



#### IMPORTANT

##### Front bezel air filter service reminders:

- HPE recommends changing the filter at least every three to six months.
- Upon installation of the FIO front bezel, a filter change timer is triggered in iLO.
- To remind users of the service life of the filter, iLO will send notification messages at 85 days and 90 days of operation. The iLO notification will indicate that the filter is about to or has reached its maximum limit for high particulate environments. After reaching this limit, it is advised that the air filter be inspected and replaced if necessary to ensure optimal performance.



#### NOTE

When resetting iLO to the factory default settings, the iLO filter change timer setting is erased and the timer is disabled. For more information on the timer reset procedures, see [Resetting the iLO filter change timer](#).

## Procedure

1. If installed, remove the Kensington security lock.

For more information, see the lock documentation.

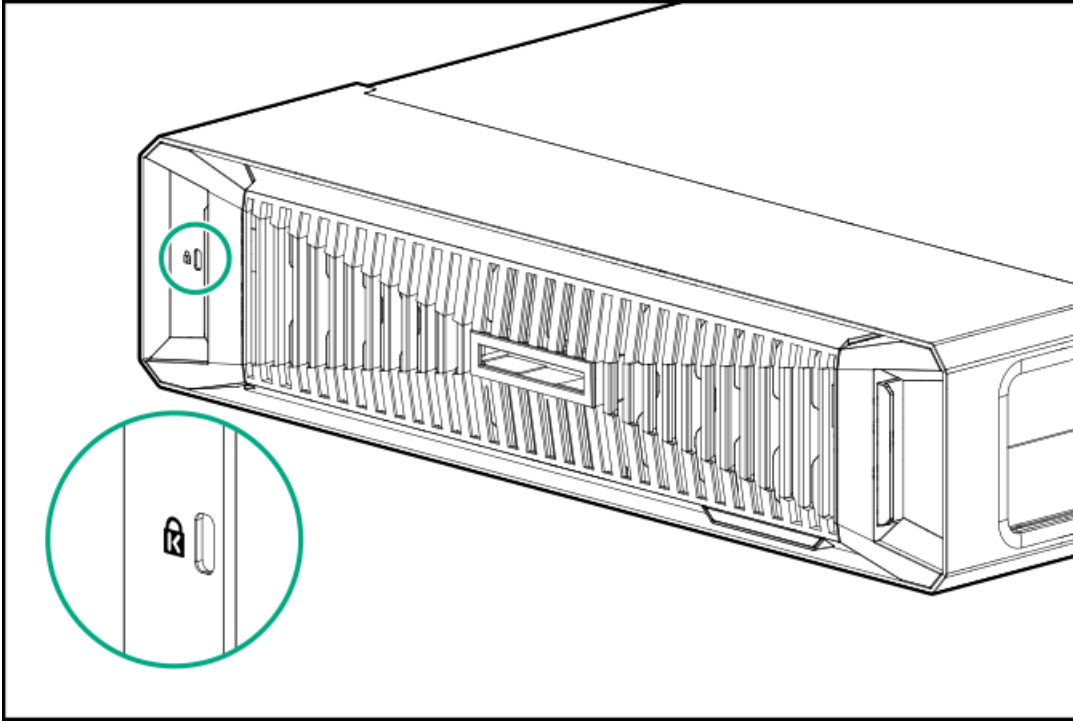

2. Press and hold the bezel release latch, and then slide out the bezel.

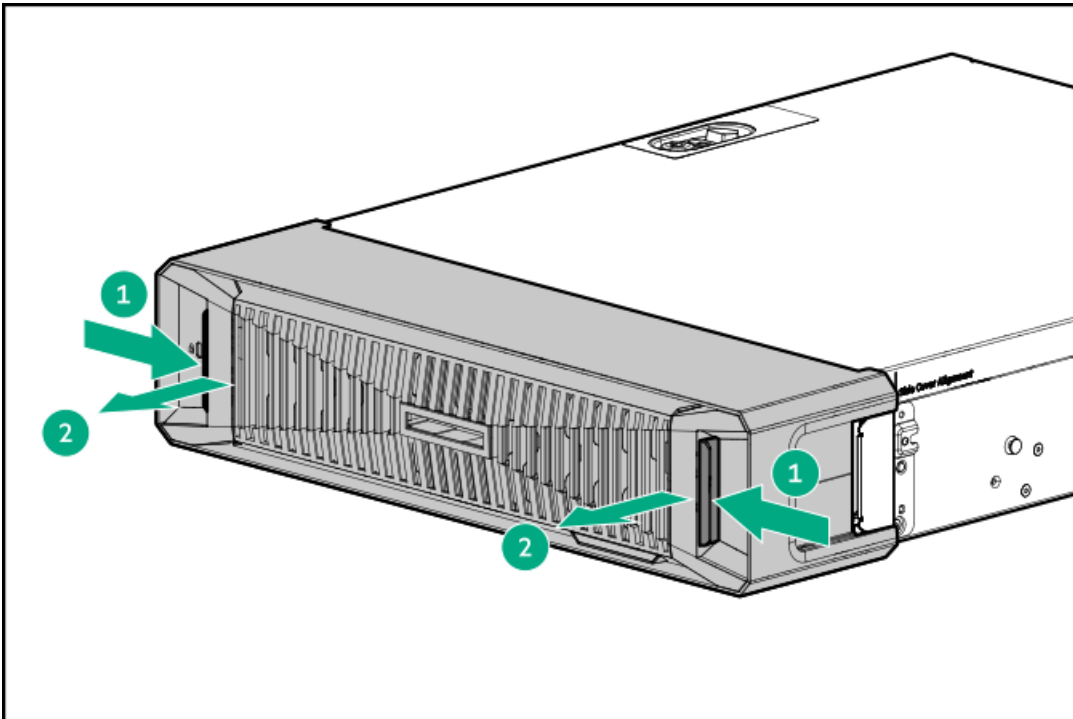

3. Press and hold the release latches on both sides of the filter cover, and then push the filter cover out.

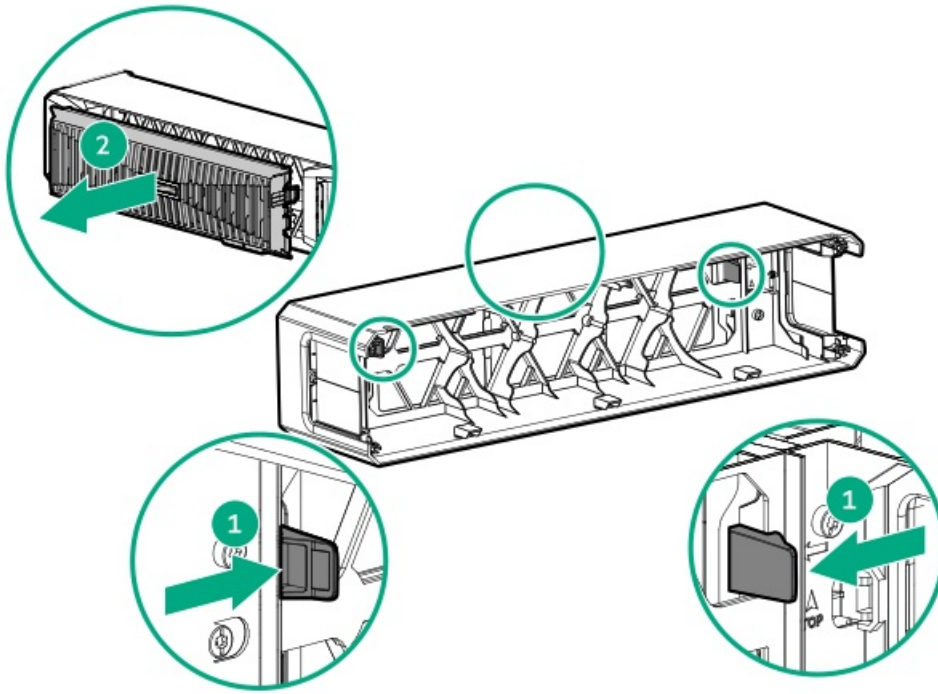

4. Remove the bezel filter:

- a. Use the blue touchpoints to pull out the filter bracket.
- b. Remove the filter.

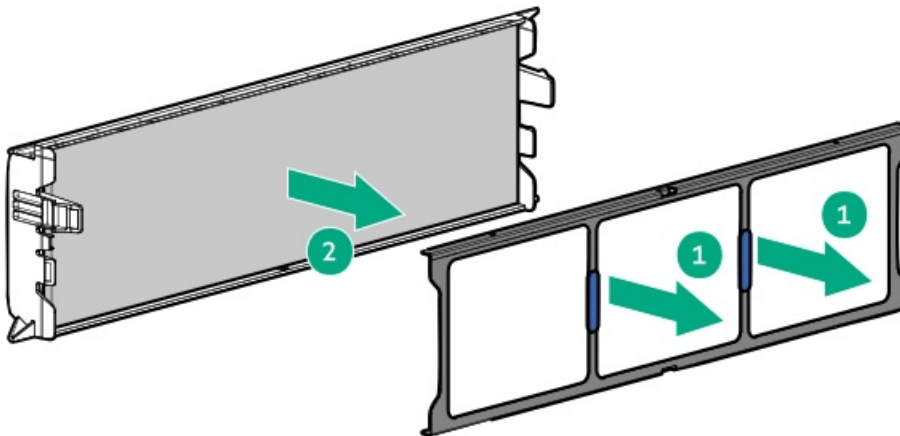

#### Installing the new filter

5. Install the bezel filter:

- a. Position the new filter on the filter cover.
- b. Use the blue touchpoints to push the filter bracket down into place.

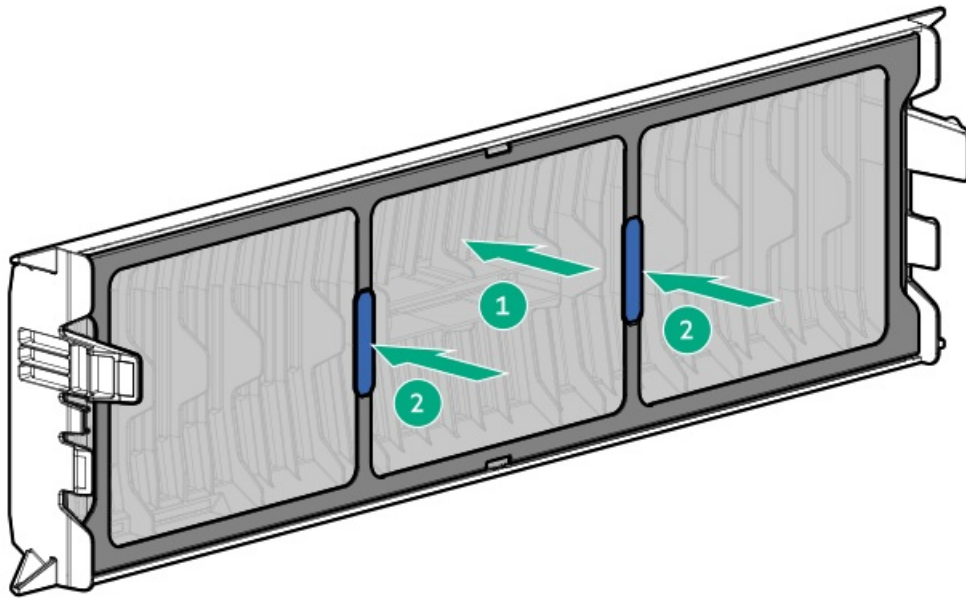

6. Install the filter cover:

- a. Position the front bezel in a horizontal orientation. The arrow on the back side of the bezel should be pointing up.

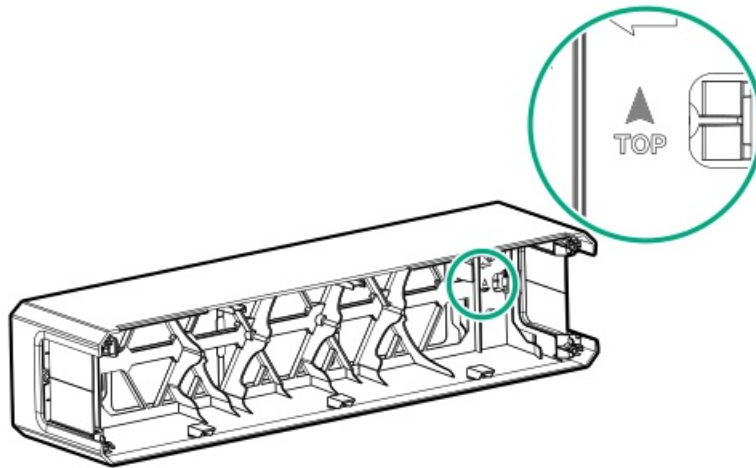

- b. Insert the filter cover at an angle.

c.  **WARNING**

To reduce the risk of personal injury, be careful when installing the filter cover. The latch could pinch your fingers.

Press and hold the latch, and then press the cover down until it clicks into place.



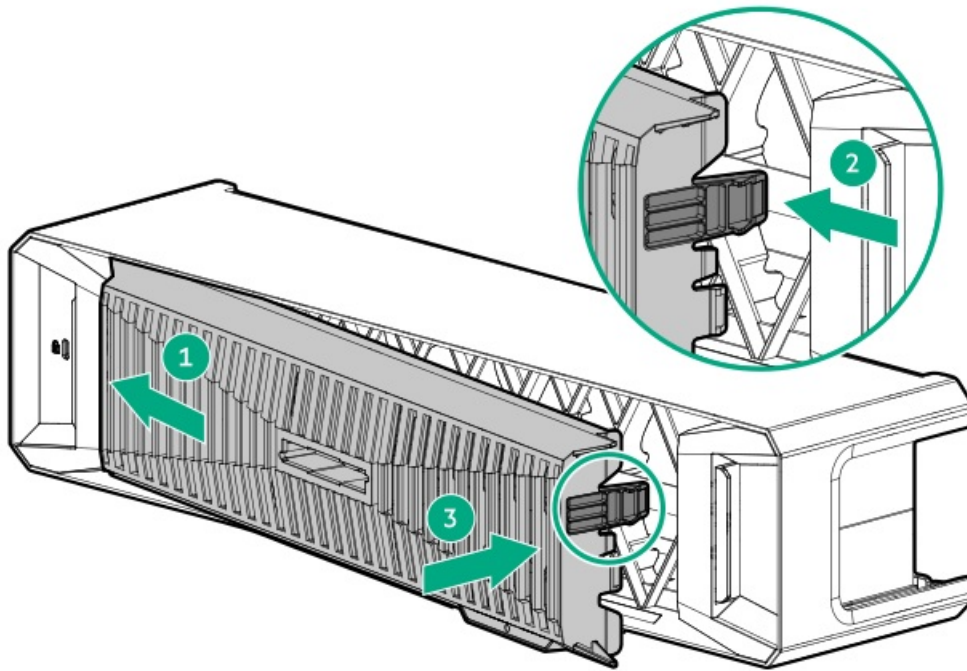

7. Install the front bezel:

- a. Slide the front bezel to engage with the front bezel brackets.
- b. Press and hold the latches on the bezel.
- c. While holding the latches, push the bezel to make sure it is fully engaged with the brackets.

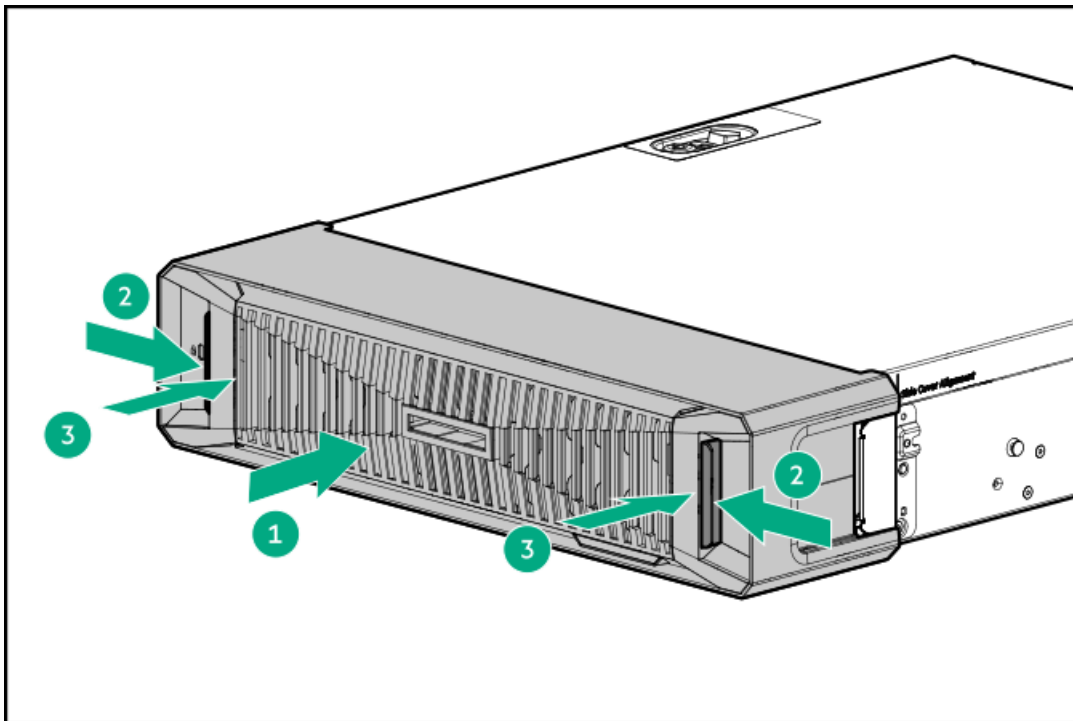

8. (Optional) Install the Kensington security lock.

For more information, see the lock documentation.

9. Reset the iLO filter change timer.

**Results**

The replacement procedure is complete.

## Resetting the iLO filter change timer

The iLO filter change timer on the server will be triggered after configuring filter timer notification.

When the default timer runs out after 85/90 days, iLO will send a notification and record an event in the [Integrated Management Log \(IML\)](#). At which point, the timer can be reset after the replacement filter is installed, or disabled if necessary.

To configure the server filter timer, use the following iLO RESTful API commands. These APIs support HTTPS POST or GET operation, and require Administrator privileges. If included, the payload needs to be in JSON format.

- Reset or enable the filter timer

Operation: POST

URI: /redfish/v1/managers/1/Actions/Oem/Hpe/HpeiLO.TriggerFilterChangeTimer

Payload:

```
{
  "RemainingDaysForEarlyReminder": 85,
  "RemainingDaysForCriticalReminder": 90,
}
```

The payload is optional. If the payload is empty, iLO will reset or enable the timer to the following default values (JSON):

- "RemainingDaysForEarlyReminder":85

This variable indicates on the 85th day, iLO will send this notification:

"The air filter installed in the server has now operated for 85 days and will reach its maximum usage limit for high particulate environments in 5 days."

- "RemainingDaysForCriticalReminder":90

This variable indicates on the 90th day, iLO will send this notification:

"The air filter installed in the server has now operated for 90 days and has reached its maximum usage limit for high particulate environments."

To customize the timer, include the payload in the API call, and specify the values in the payload using the following variable name and value pairs (JSON). The values are the days before the timer expires.

```
{
  "RemainingDaysForEarlyReminder": 55,
  "RemainingDaysForCriticalReminder": 60,
}
```

- Disable the filter timer

Operation: POST

URI: /redfish/v1/managers/1/Actions/Oem/Hpe/HpeiLO.DisableFilterChangeTimer

Payload: None

- Query the filter timer record

Operation: GET

URI: /redfish/v1/managers/1

Property name: AirFilterRecord (type: array)

To access the iLO RESTful API, use the iLO interface tool or a REST client application. For more information on iLO RESTful API and RESTful Interface Tool, see:

## Removing and replacing a hot-plug SFF/E3.S drive

### About this task

[https://sketchfab.com/models/2d21243d5f194a5ea4d4c79657e77e74/embed?ui\\_infos=0&ui\\_watermark=0&ui\\_help=0&ui\\_vr=0&ui\\_settings=0&ui\\_inspector=0&ui\\_hint=2&ui\\_color=01a982&ui\\_theme=dark&autostart=1&camera=0&](https://sketchfab.com/models/2d21243d5f194a5ea4d4c79657e77e74/embed?ui_infos=0&ui_watermark=0&ui_help=0&ui_vr=0&ui_settings=0&ui_inspector=0&ui_hint=2&ui_color=01a982&ui_theme=dark&autostart=1&camera=0&)



#### CAUTION

A discharge of static electricity from a finger or other conductor might damage system boards or other static-sensitive devices. To prevent damage, observe [antistatic precautions](#).



#### CAUTION

To prevent improper cooling and thermal damage, do not operate the server unless all bays are populated with either a component or a blank.

### Procedure

1. [Back up all server data](#).
2. If installed, [remove the front bezel](#).
3. Observe the drive LED status and determine if the drive can be removed.
  - [SFF drive](#)
  - [E3.S drive](#)
4. Remove the drive.
  - SFF drive

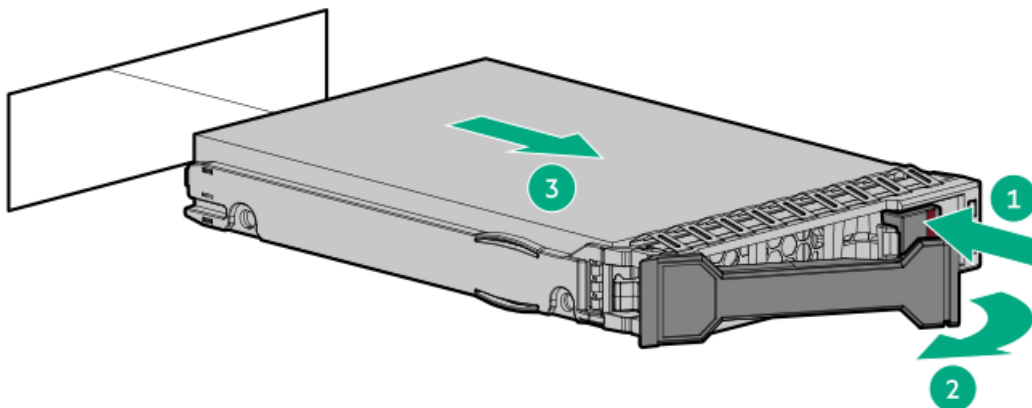

- E3.S drive

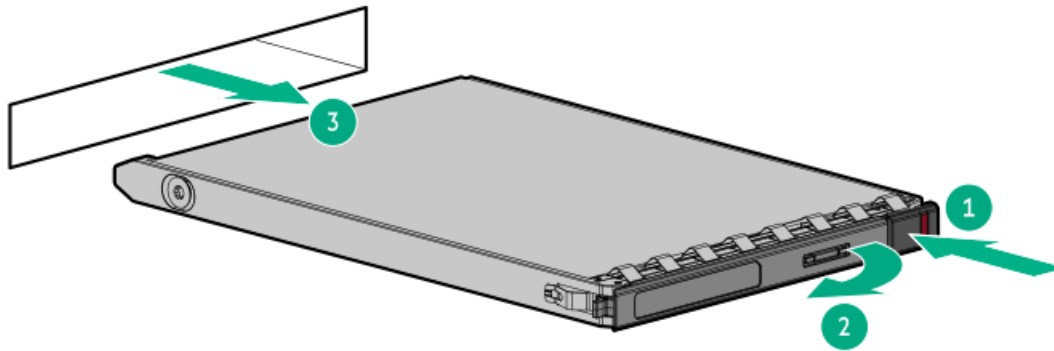

## Results

The removal procedure is complete. To replace the component, reverse this procedure.

## Removing and replacing a drive blank

### About this task

[https://sketchfab.com/models/f3af92d159ca4b539038797170e9428a/embed?ui\\_infos=0&ui\\_watermark=0&ui\\_help=0&ui\\_vr=0&ui\\_settings=0&ui\\_inspector=0&ui\\_hint=2&ui\\_animations=0&ui\\_color=01a982&ui\\_theme=dark&autostart=1&camera=0](https://sketchfab.com/models/f3af92d159ca4b539038797170e9428a/embed?ui_infos=0&ui_watermark=0&ui_help=0&ui_vr=0&ui_settings=0&ui_inspector=0&ui_hint=2&ui_animations=0&ui_color=01a982&ui_theme=dark&autostart=1&camera=0)



#### CAUTION

To prevent improper cooling and thermal damage, do not operate the server unless all bays are populated with either a component or a blank.

### Procedure

1. If installed, remove the front bezel.
2. Remove the drive blank.
  - SFF drive blank

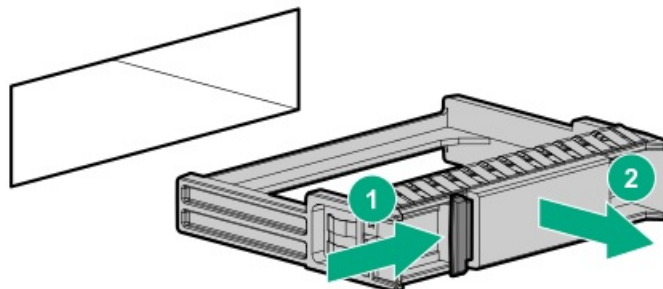

- E3.S drive blank

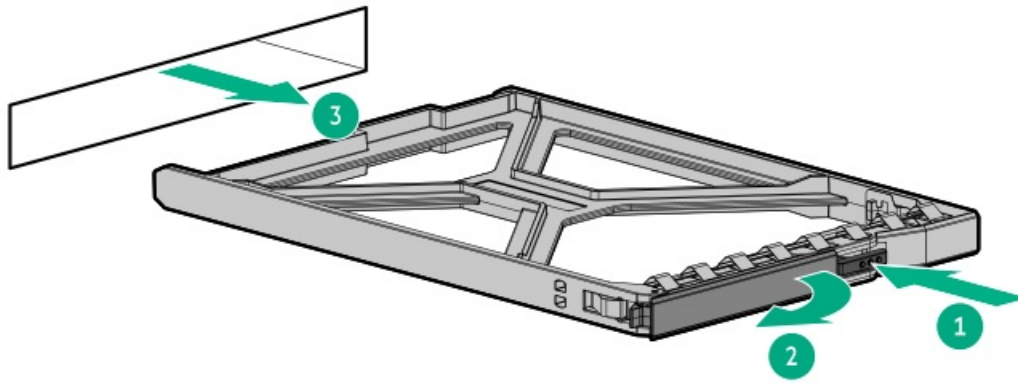

## Results

The removal procedure is complete. To replace the component, reverse this procedure.

## Removing and replacing an E3.S drive cage filler

### Prerequisites

Before you perform this procedure, make sure that you have a small slotted screwdriver available.

### About this task

[https://sketchfab.com/models/be12fb70179e4650ad08a5f691195e82/embed?ui\\_infos=0&ui\\_watermark=0&ui\\_help=0&ui\\_vr=0&ui\\_settings=0&ui\\_inspector=0&ui\\_hint=2&ui\\_color=01a982&ui\\_theme=dark&autostart=1&camera=0&](https://sketchfab.com/models/be12fb70179e4650ad08a5f691195e82/embed?ui_infos=0&ui_watermark=0&ui_help=0&ui_vr=0&ui_settings=0&ui_inspector=0&ui_hint=2&ui_color=01a982&ui_theme=dark&autostart=1&camera=0&)



#### CAUTION

To prevent improper cooling and thermal damage, do not operate the server unless all bays are populated with either a component or a blank.

## Procedure

1. If installed, remove the front bezel.
2. Remove the E3.S drive cage filler:
  - a. Insert a small-slotted screwdriver into the slot on the far left to push the release latch.
  - b. Remove the E3.S drive cage filler.

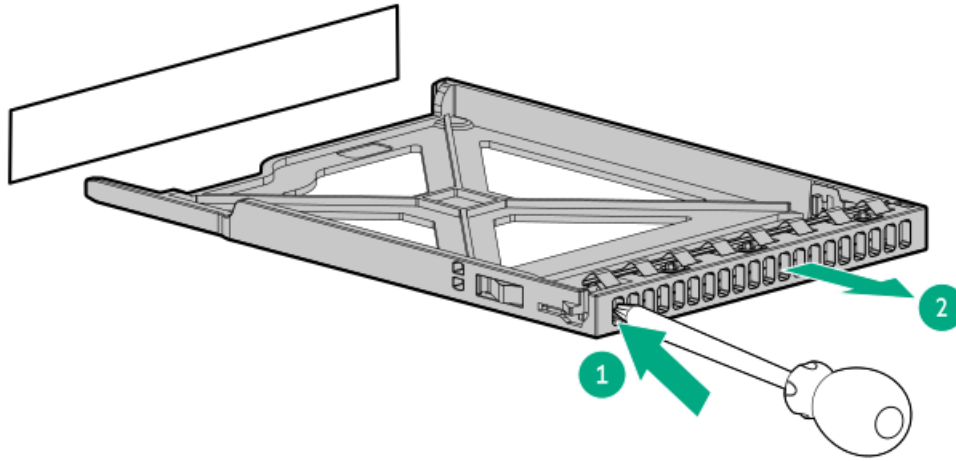

## Results

The removal procedure is complete. To replace the component, reverse this procedure.

## Flexible Slot power supply replacement

Depending on the configuration and the regional location where the server was purchased, the server can be configured with one of the supported [power supplies](#).

### Subtopics

[Power supply warnings and cautions](#)

[DC power supply warnings and cautions](#)

[Removing and replacing a Flexible Slot power supply](#)

## Power supply warnings and cautions



### WARNING

To reduce the risk of electric shock or damage to the equipment:

- Do not disable the power cord grounding plug. The grounding plug is an important safety feature.
- Plug the power cord into a grounded (earthed) electrical outlet that is easily accessible at all times.
- Unplug the power cord from the power supply to disconnect power to the equipment.
- Do not route the power cord where it can be walked on or pinched by items placed against it. Pay particular attention to the plug, electrical outlet, and the point where the cord extends from the server.



### WARNING

To reduce the risk of injury from electric shock hazards, do not open power supplies. Refer all maintenance, upgrades, and servicing to qualified personnel.



### CAUTION

Mixing different types of power supplies in the same server might:

- Limit or disable some power supply features including support for power redundancy.
- Cause the system to become unstable and might shut down.

To ensure access to all available features, all power supplies in the same server should have the same output and efficiency ratings. Verify that all power supplies have the same part number and label color.

## DC power supply warnings and cautions



### WARNING

To reduce the risk of electric shock, be sure that the cable grounding kit is properly installed and connected to a suitable protective earth terminal before connecting the power source to the rack.



### CAUTION

This equipment is designed to permit the connection of the earthed conductor of the DC supply circuit to the earthing conductor at the equipment. If this connection is made, all the following must be met:

- This equipment must be connected directly to the DC supply system earthing electrode conductor or to a bonding jumper from an earthing terminal bar or bus to which the DC supply system earthing electrode conductor is connected.
- This equipment must be located in the same immediate area (such as adjacent cabinets) as any other equipment that has a connection between the earthed conductor of the same DC supply circuit and the earthing conductor, and also the point of earthing of the DC system. The DC system must be earthed elsewhere.
- The DC supply source is to be located within the same premises as the equipment.
- Switching or disconnecting devices must not be in the earthed circuit conductor between the DC source and the point of connection of the earthing electrode conductor.

## Removing and replacing a Flexible Slot power supply

### Prerequisites

- Before removing a power supply option, review the following:
  - Power supply warnings and cautions
  - [DC power supply warnings and cautions](#)
- If you are replacing a DC power supply, make sure that you have a Phillips No. 1 screwdriver available.

### About this task

AC power supply:

[https://sketchfab.com/models/ef1927dac07d4c40b5925173aacddb9a/embed?ui\\_infos=0&ui\\_watermark=0&ui\\_help=0&ui\\_vr=0&ui\\_settings=0&ui\\_inspector=0&ui\\_hint=2&ui\\_animations=0&ui\\_color=01a982&ui\\_theme=d](https://sketchfab.com/models/ef1927dac07d4c40b5925173aacddb9a/embed?ui_infos=0&ui_watermark=0&ui_help=0&ui_vr=0&ui_settings=0&ui_inspector=0&ui_hint=2&ui_animations=0&ui_color=01a982&ui_theme=d)



**WARNING**

To reduce the risk of personal injury from hot surfaces, allow the power supply, power supply blank, or dual slot power supply adapter to cool before touching it.



**CAUTION**

To prevent improper cooling and thermal damage, do not operate the server unless all bays are populated with either a component or a blank.

## Procedure

1. If the server is using a single power supply, remove all power from the server:
  - a. Back up all server data.
  - b. If installed, remove the front bezel.
  - c. Power down the server.
  - d. Disconnect the power cord from the power supply.
2. Release the power cords, wires, and cables from the strain relief strap.
  - AC power supply

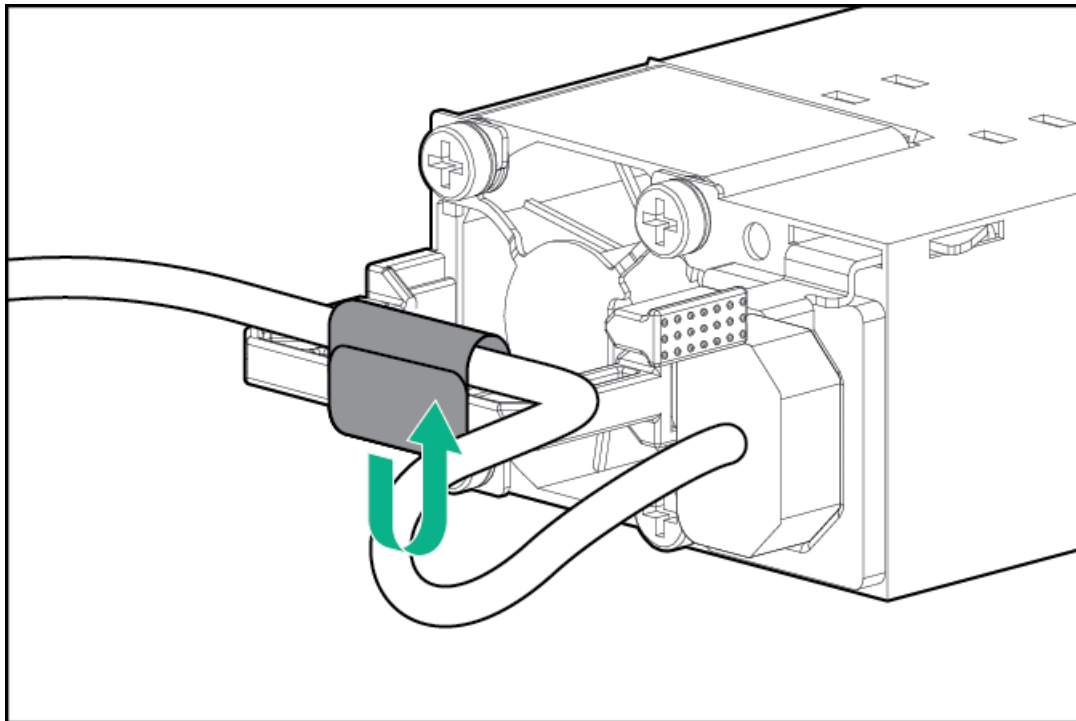

- DC power supply

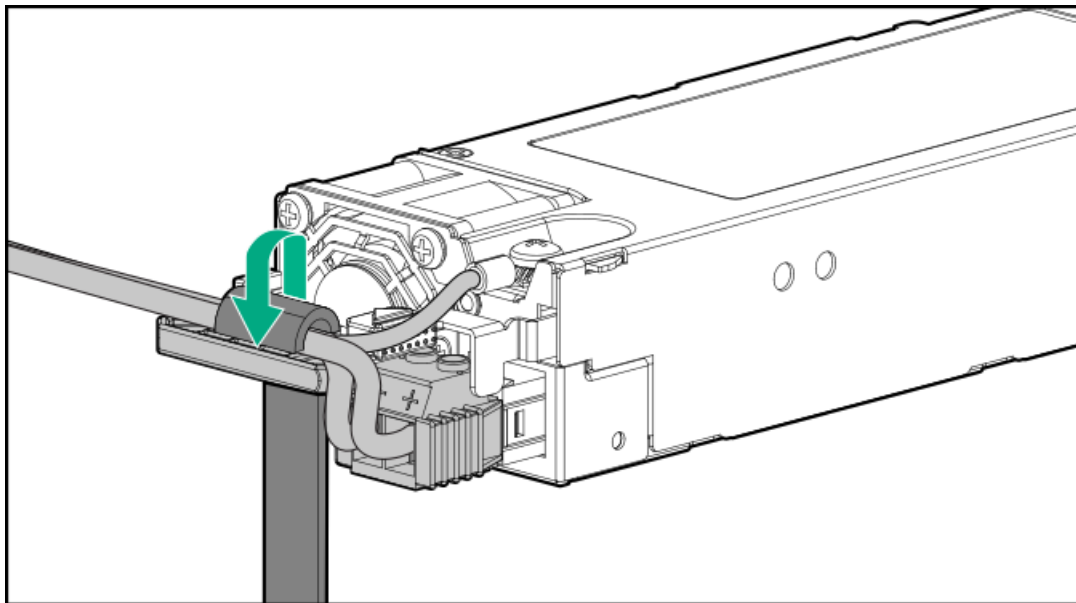

3. For an AC power supply, do the following:

- a. Disconnect the power cord from the power supply.

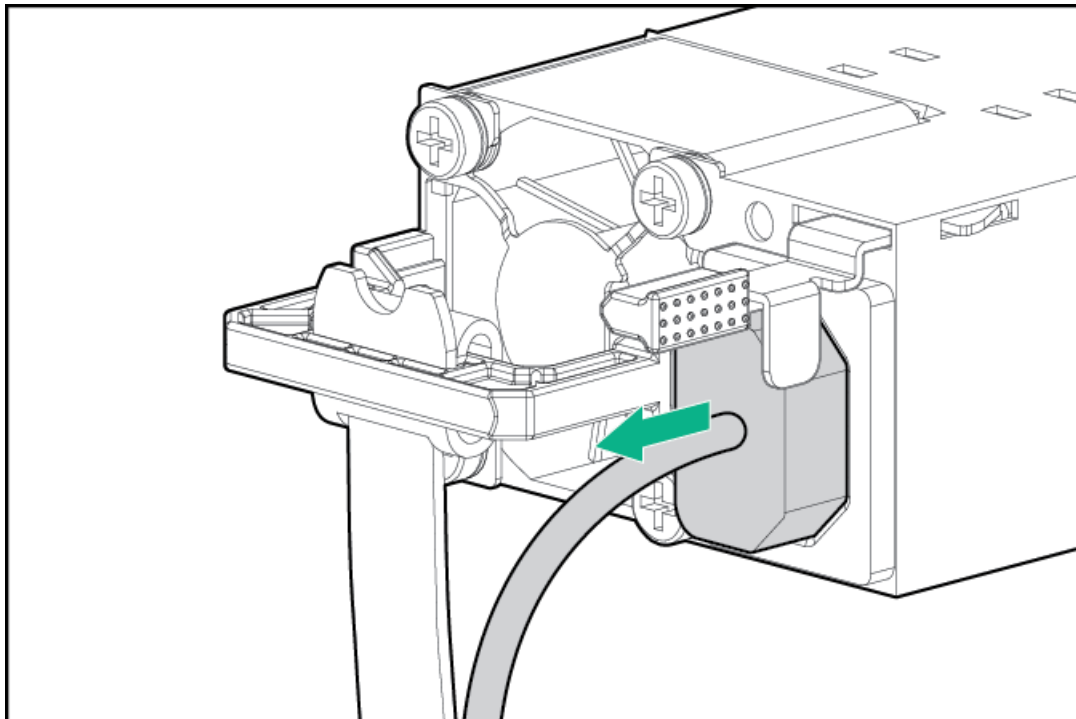

- b. Remove the power supply.

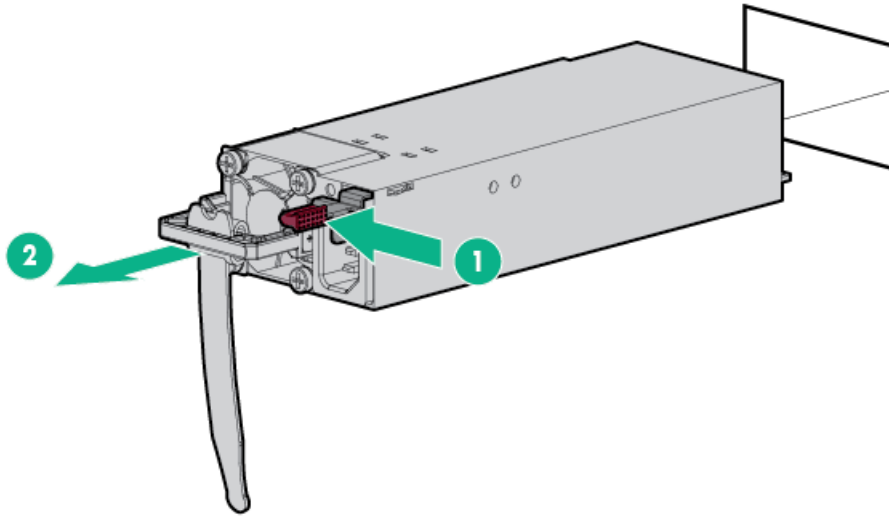

4. For a DC power supply, do the following:

- a. Slide the power supply out of the bay just enough to access the ground cable screw.

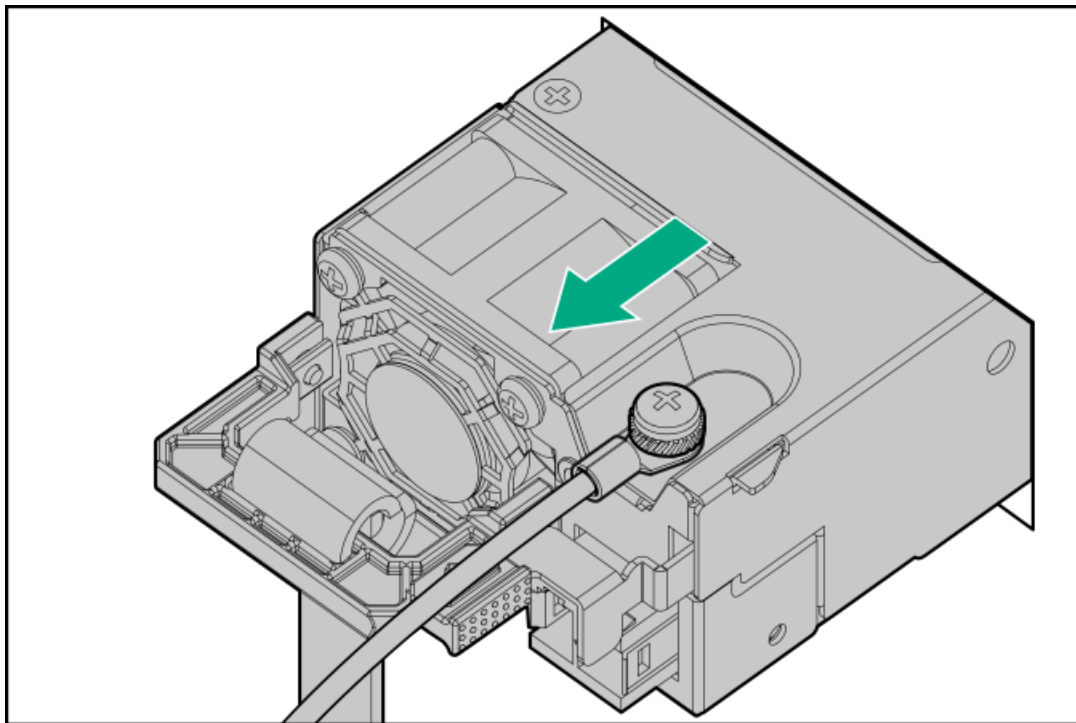

- b. Remove the ground (earthed) cable from the power supply.

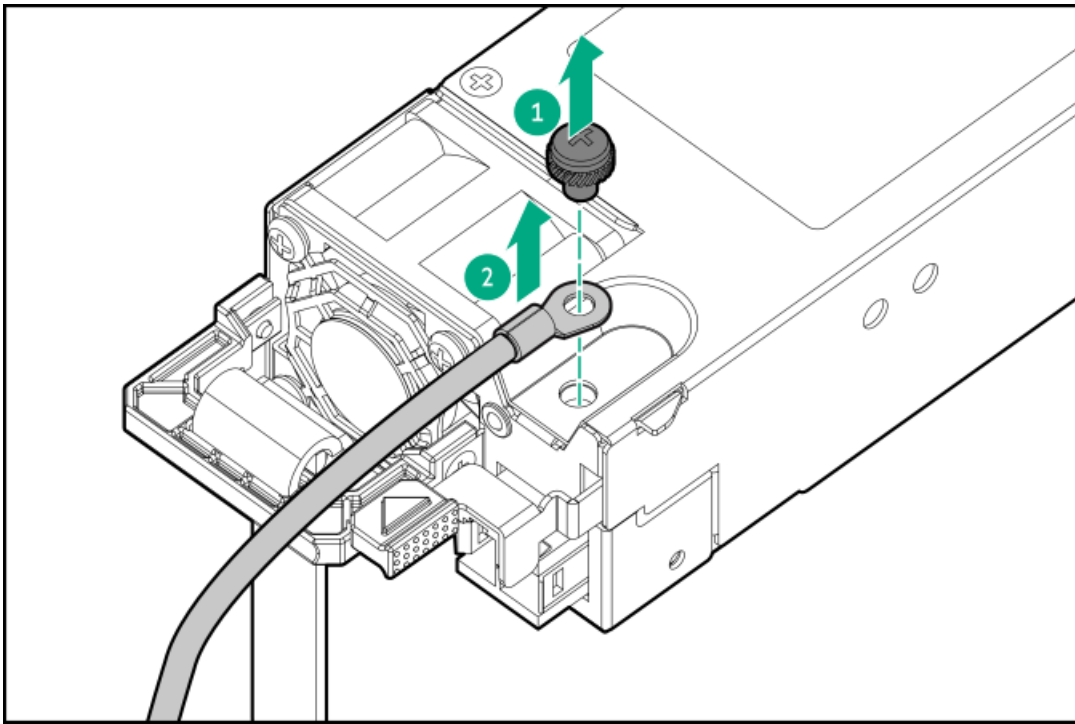

c. Remove the terminal block connector from the power supply.

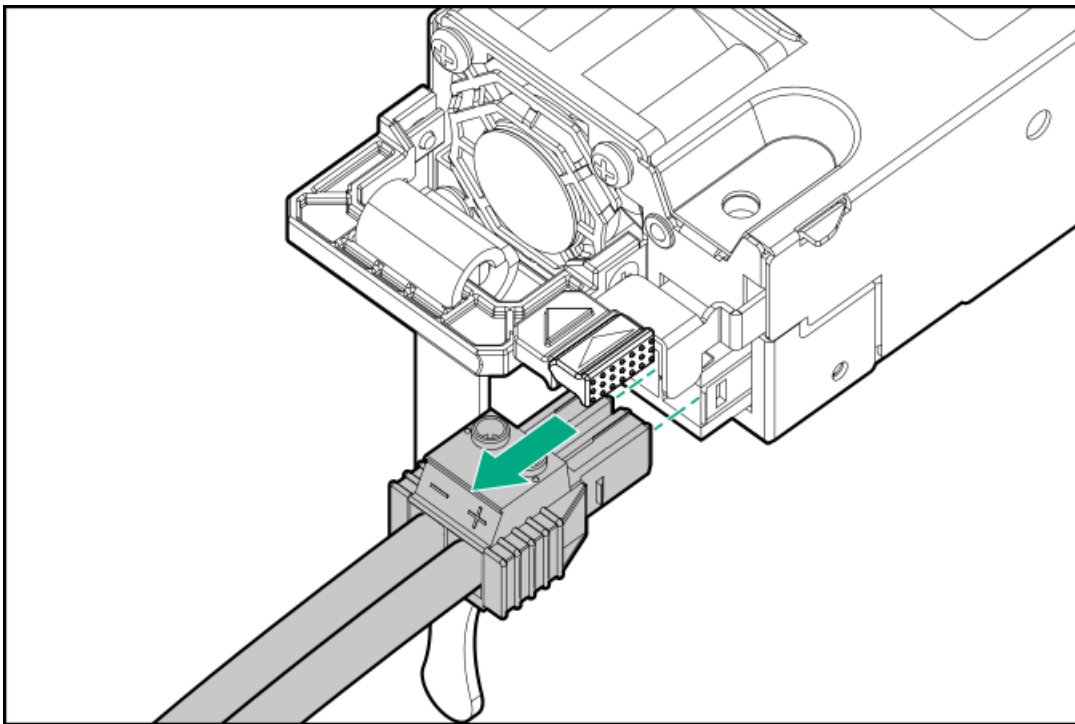

d. Remove the power supply.



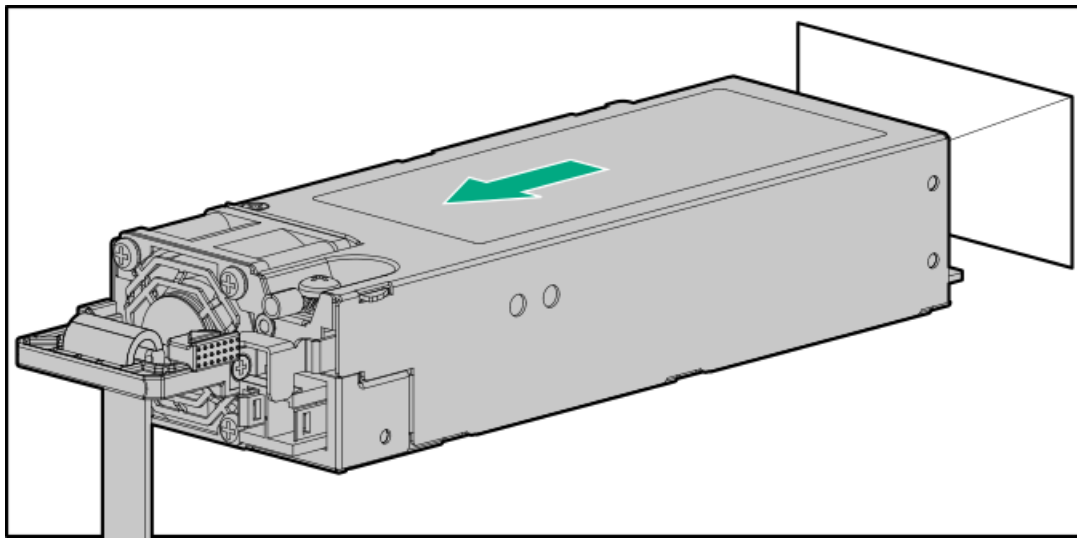

## Results

The removal procedure is complete. To replace the component, reverse this procedure.

## Removing and replacing the side covers

### Prerequisites

Before you perform this procedure, make sure that you have a T-10 Torx screwdriver available.

### Procedure

1. If installed, remove the front bezel.
2. Power down the server.
3. Remove all power:
  - a. Disconnect each power cord from the power source.
  - b. Disconnect each power cord from the server.
4. Disconnect all peripheral cables from the server.
5. Place the server on a flat, level work surface.
6. Remove the side covers:
  - a. Unlock the side covers.
  - b. Slide the side covers toward the rear of the server, and then remove the side covers.

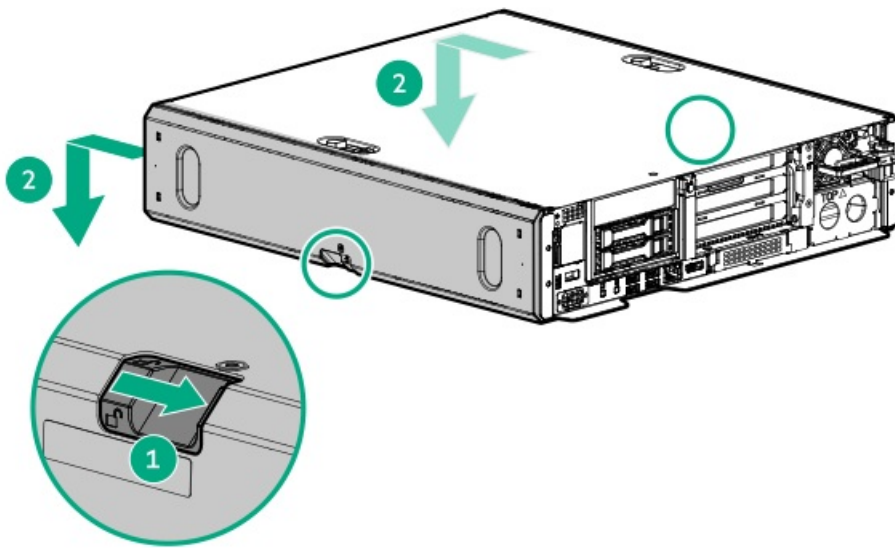

7. Remove the side cover brackets.

- a. Loosen the screws on the bracket on both sides of the chassis.
- b. Remove the brackets.

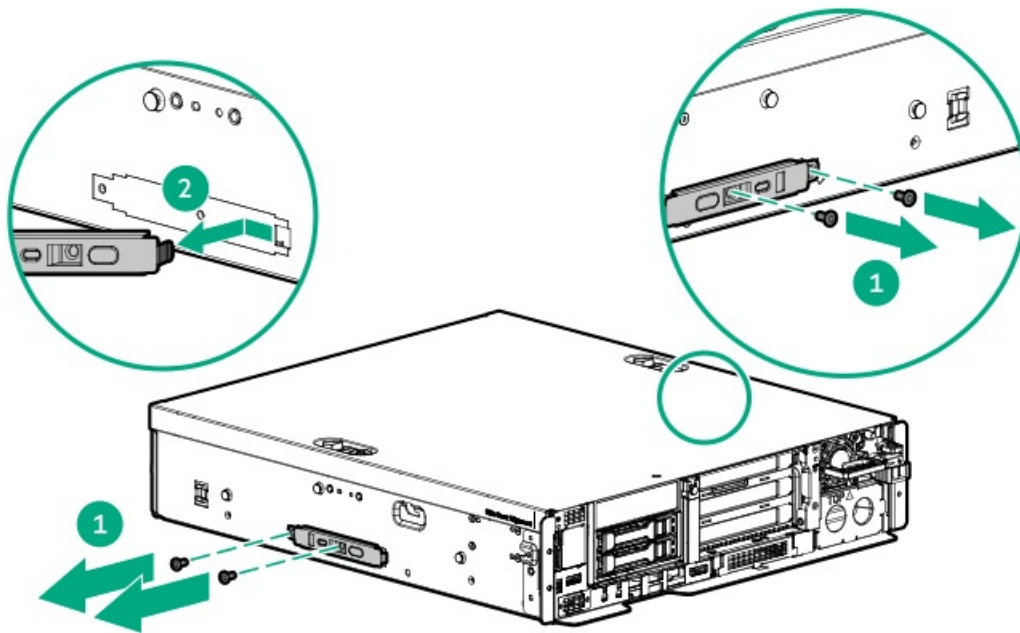

**Results**

The removal procedure is complete. To replace the component, reverse this procedure.

**Removing and replacing the wall mount connecting brackets**

**Prerequisites**

- Get help to lift and stabilize the server during removal from the wall mount. If the server is installed higher than chest level, **an additional person might be required to help remove the server**: One person to support the server weight, and the other to remove the server from the wall mount.

- Before you perform this procedure, make sure that you have a T-10 Torx screwdriver available.

## Procedure

1. If installed, remove the front bezel.
2. Power down the server.
3. Remove all power:
  - a. Disconnect each power cord from the power source.
  - b. Disconnect each power cord from the server.
4. Disconnect all peripheral cables from the server.
5. Push the latch on the cover on both sides to unlock the server.

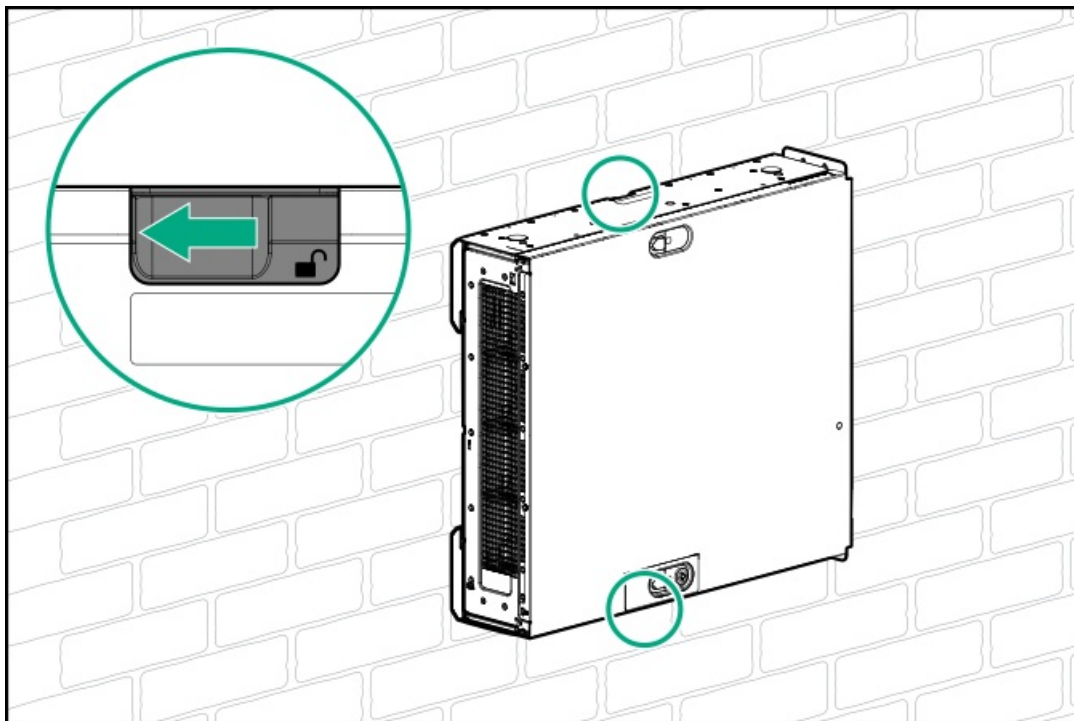

6. Use two hands to slide the chassis toward the front of the server to disengage it from the wall mount, and then lift the chassis away from the wall mount.

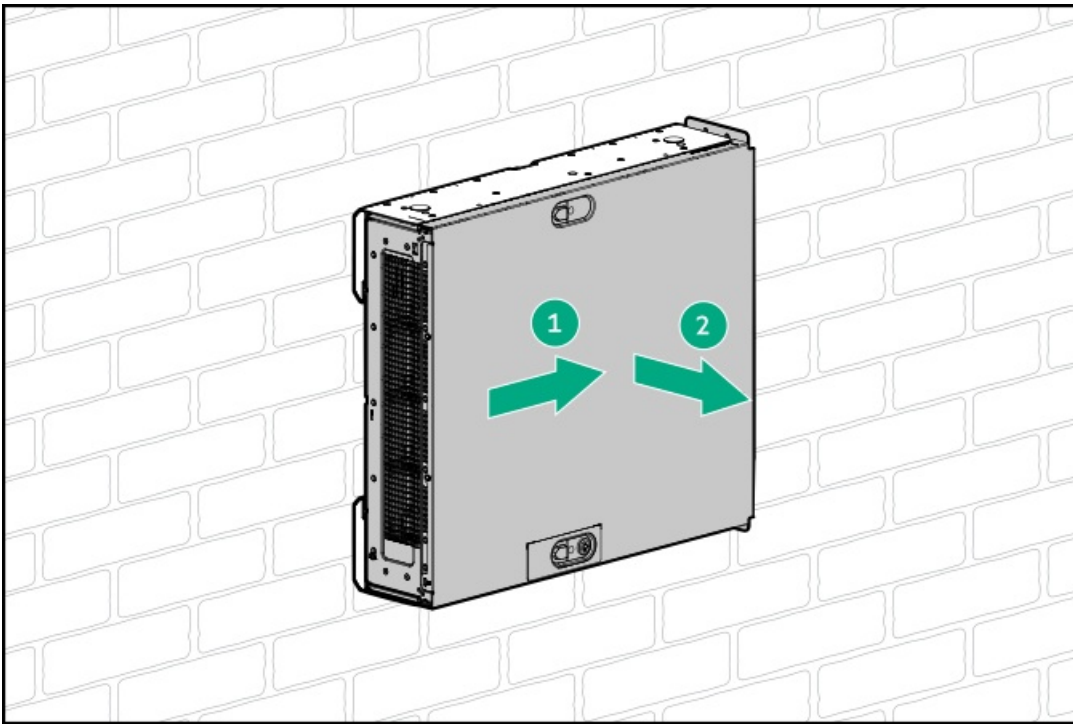

7. Remove the screws, and then remove the wall mount from the wall.

Support the wall mount when removing the screws.

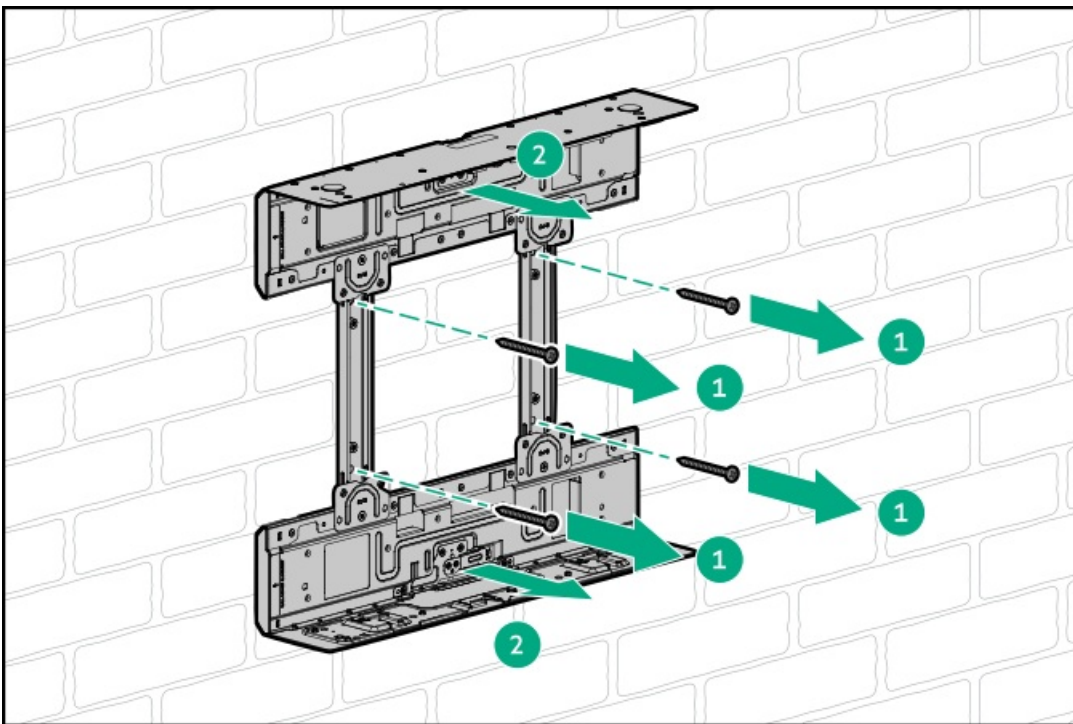

8. Remove the screws, and then remove the wall mount connecting brackets from the side covers.



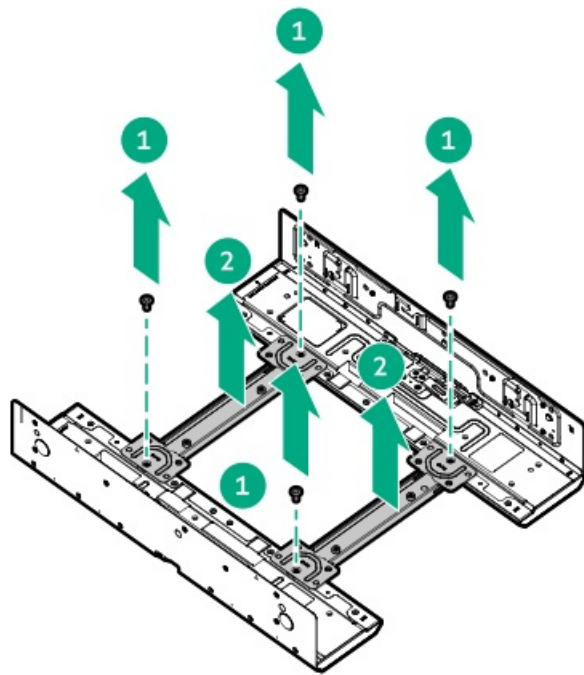

## Results

The removal procedure is complete. To replace the component, reverse this procedure.

## Removing and replacing the cable management arm

### About this task



#### CAUTION

Support the CMA during the removal and replacement procedures. Do not allow the CMA to hang by its own weight during the procedure.

### Procedure

1. Open the cable clamps.

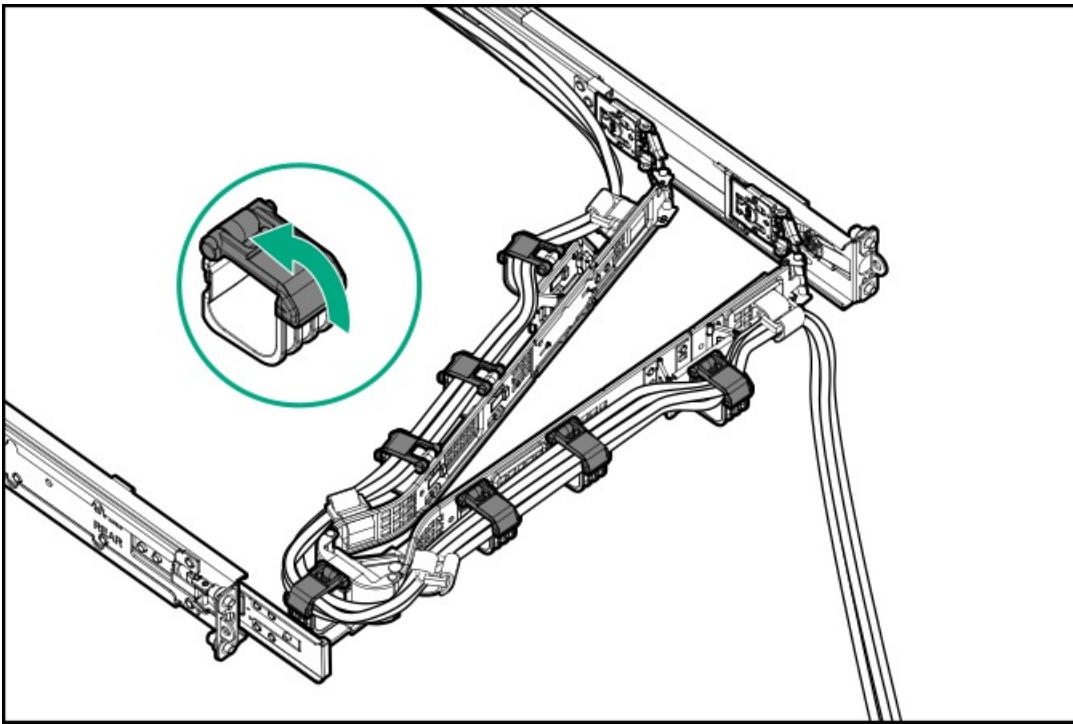

2. (Optional) If your CMA has cable straps, unwrap the straps.

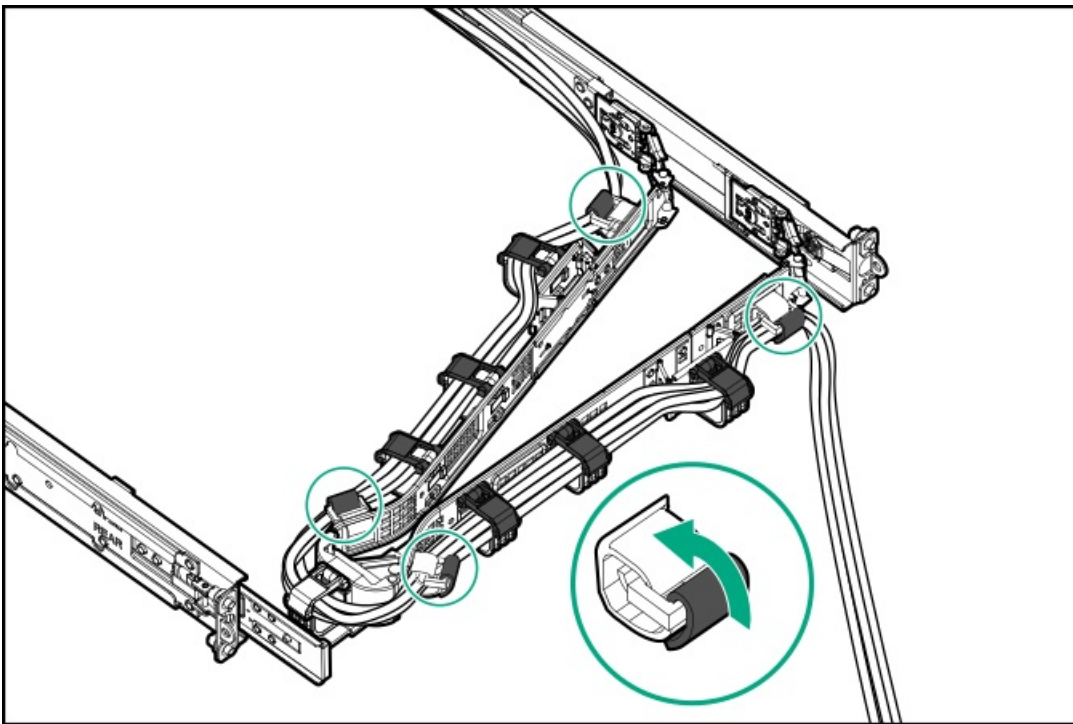

3. Remove the peripheral cables and power cords from the CMA.

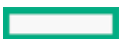

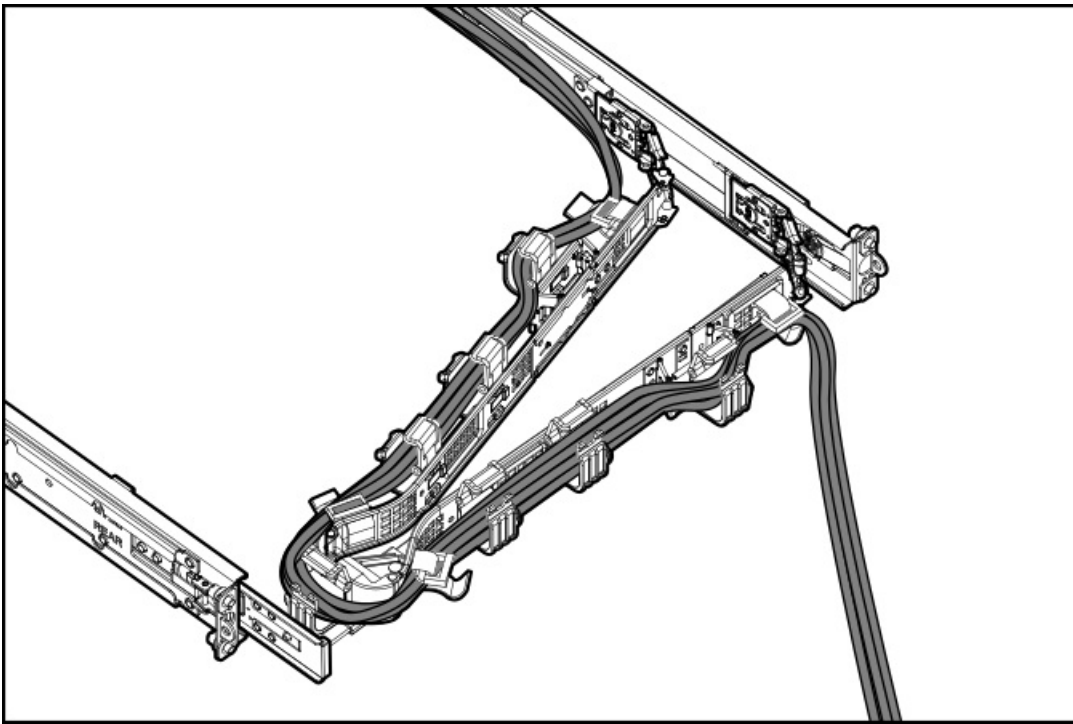

4. Remove the cable management arm:

- a. Press and hold the blue **PUSH** button on the retention bracket.
- b. Swing the arm away from the mounting rail.
- c. Press and hold the blue **PUSH** buttons on the outer and inner tabs and detach from the rack rails.

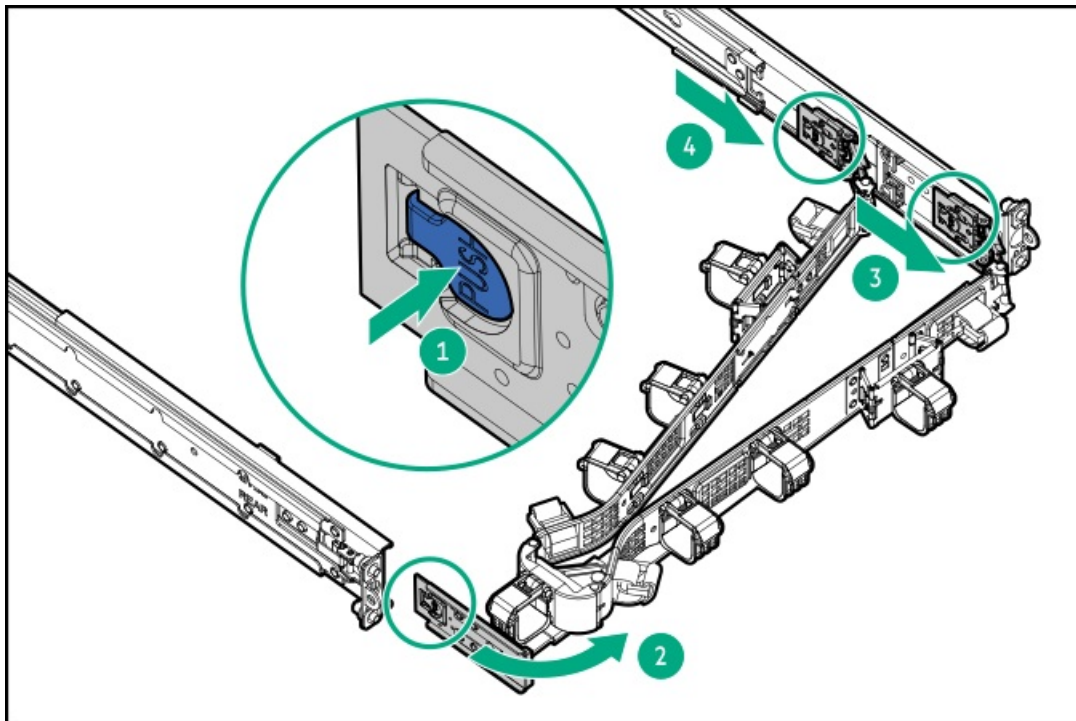

**Results**

The removal procedure is complete. To replace the component, reverse this procedure.

**Removing and replacing the rack rails**

## Removing and Replacing the Rack Rails

### Prerequisites

If you are replacing the rack mounting rails from a threaded-hole rack, make sure that you have a T-25 Torx screwdriver available.

### About this task

The illustrations used in this procedure show an icon on the upper right corner of the image. This icon indicates whether the action shown in the image is for a round-hole, square-hole, or a threaded-hole rack.

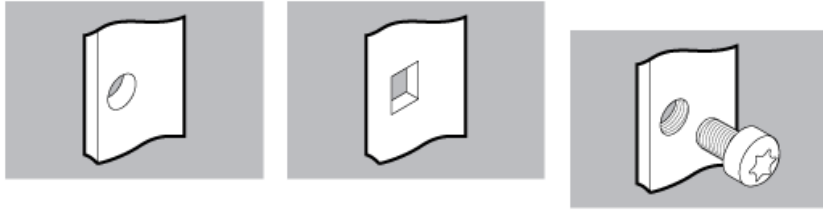

Round-hole rack

Square-hole rack

Threaded-hole rack

### Procedure

1. If installed, remove the front bezel.
2. Power down the server.
3. Remove all power:
  - a. Disconnect each power cord from the power source.
  - b. Disconnect each power cord from the server.
4. Disconnect all peripheral cables from the server.
5. Remove the server from a four-post rack.
6. Place the server on a flat, level work surface.
7. Push the sliding rails toward the front panel, and then lift them away from the rack mount brackets.

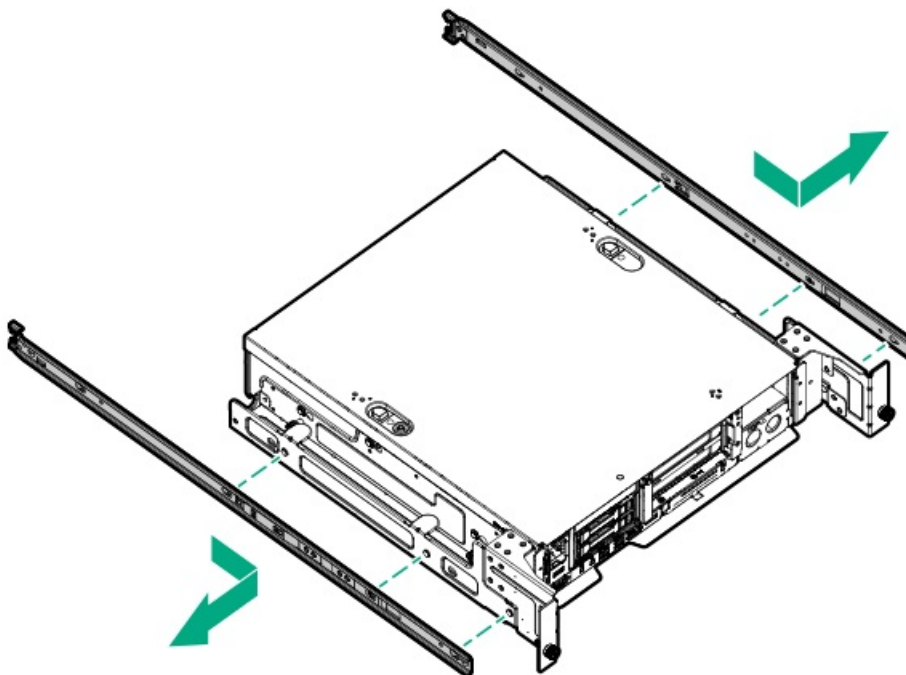

8. To remove the rack mounting rails, do the following:

a. In a threaded-hole rack, remove the rail screws.

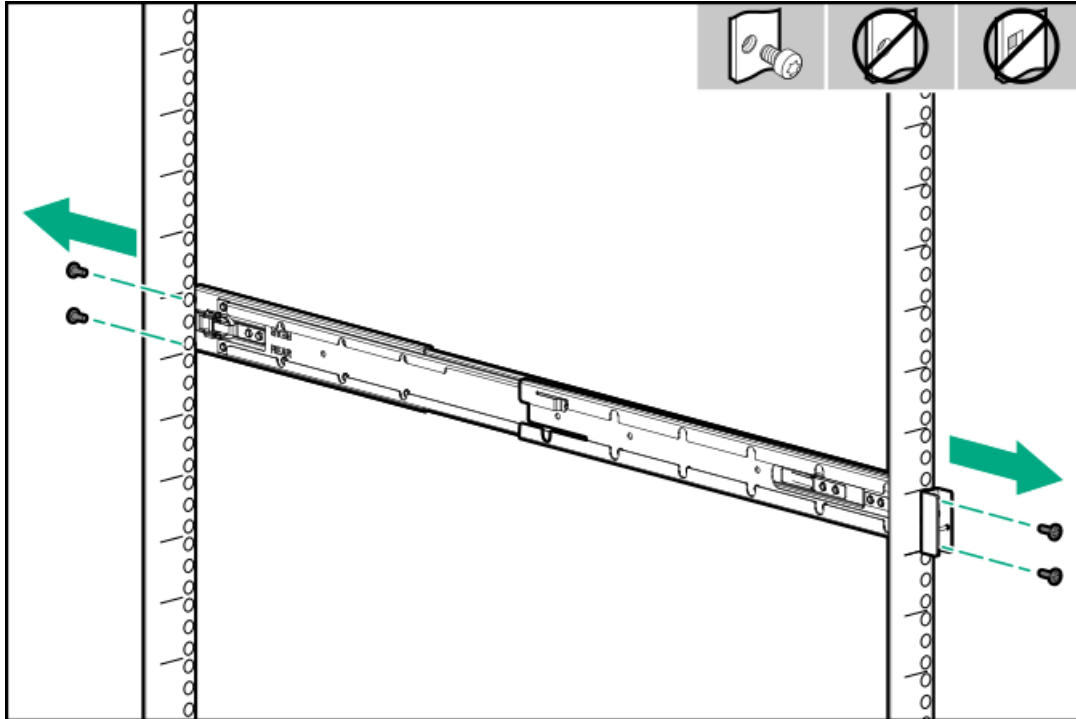

b. Disengage the rail pins from the rack columns.

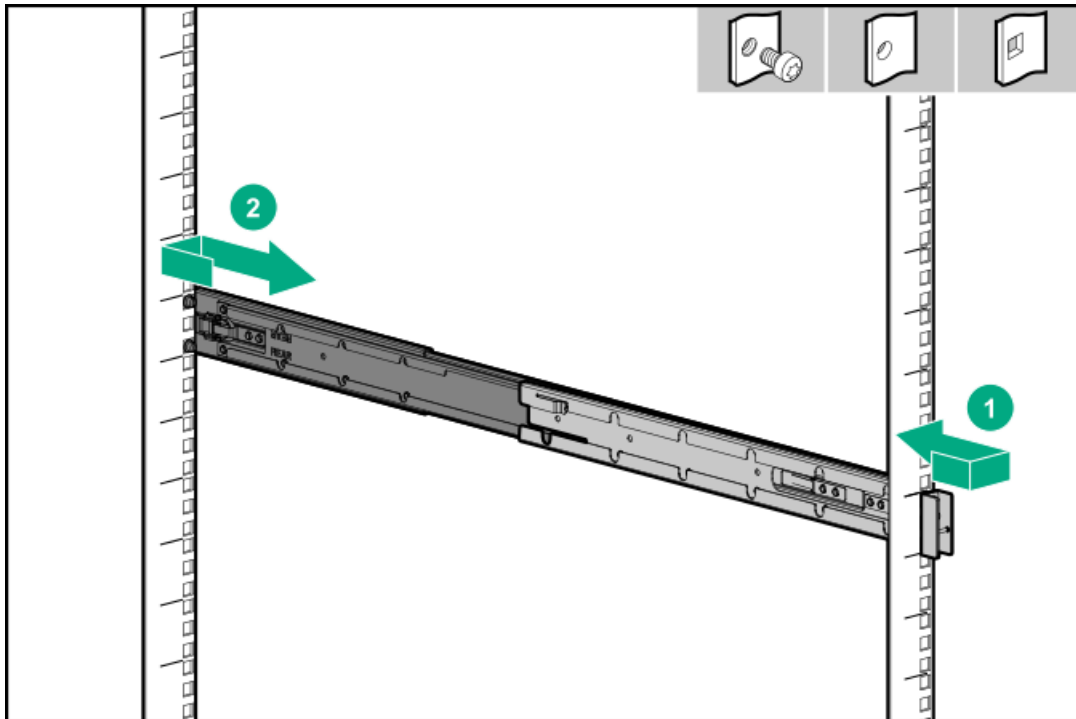

c. Repeat steps a and b to remove the other rack rail.

## Results

The removal procedure is complete. To replace the component, reverse this procedure.

## Removing and replacing the rack mount brackets

## Prerequisites

Before you perform this procedure, make sure that you have a T-15 Torx screwdriver available.

## Procedure

1. If installed, remove the front bezel.
2. Power down the server.
3. Remove all power:
  - a. Disconnect each power cord from the power source.
  - b. Disconnect each power cord from the server.
4. Disconnect all peripheral cables from the server.
5. Remove the server from a four-post rack.
6. Place the server on a flat, level work surface.
7. Push the sliding rails toward the front panel, and then lift them away from the rack mount brackets.

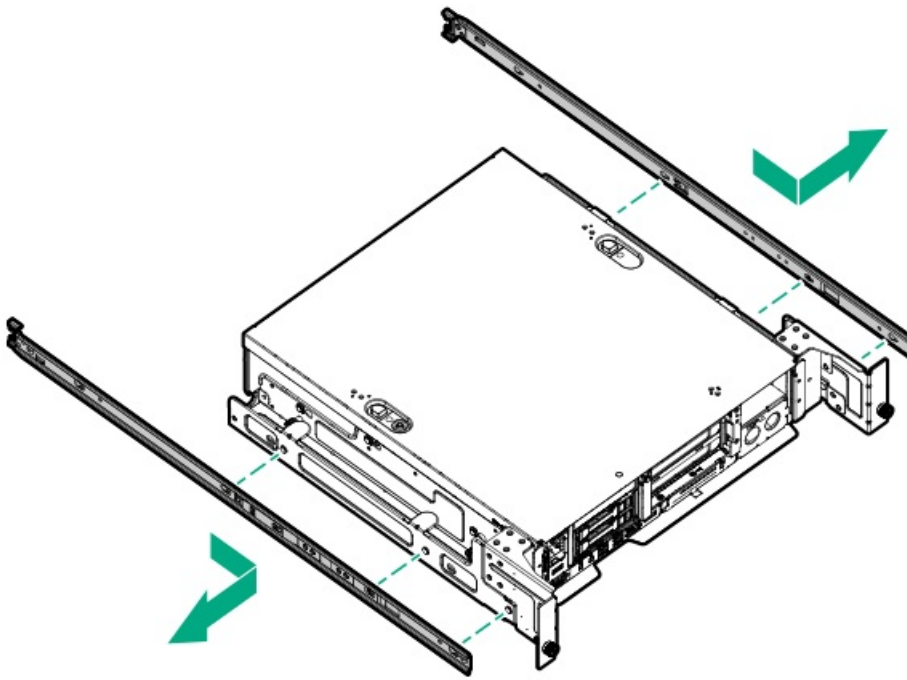

8. Remove the right rack mount bracket:
  - a. Loosen the thumbscrews.
  - b. Slide the bracket toward the rear panel to disengage it from the spools on the chassis, and then remove the bracket.

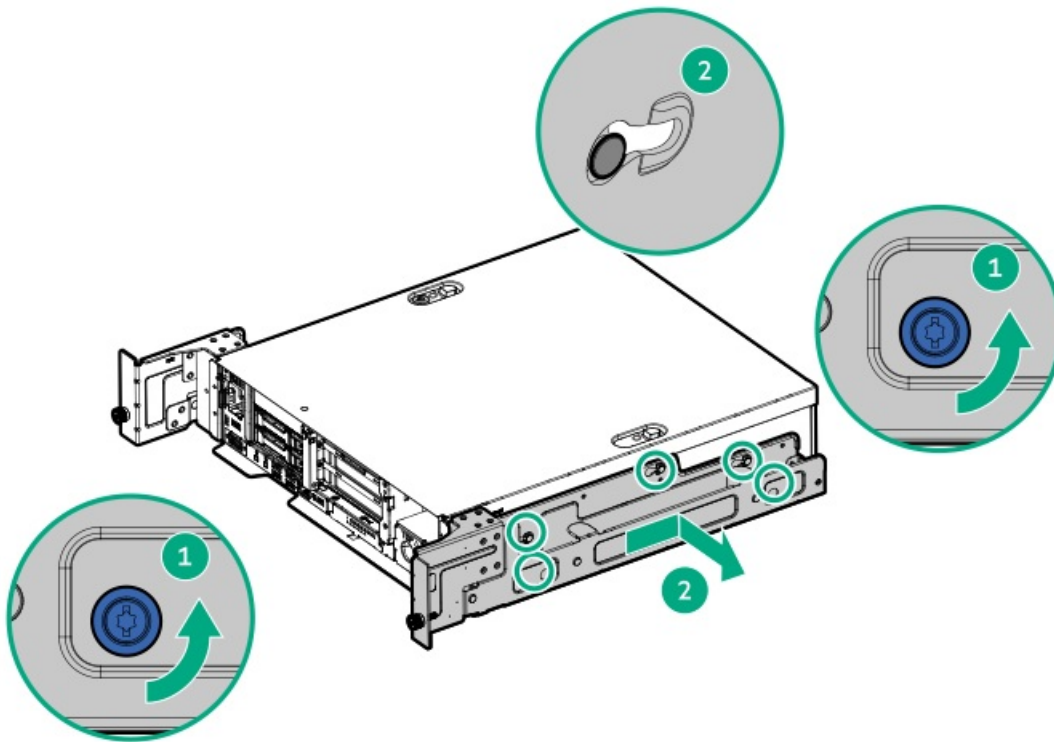

9. Repeat step 8 to remove the left rack mount bracket.

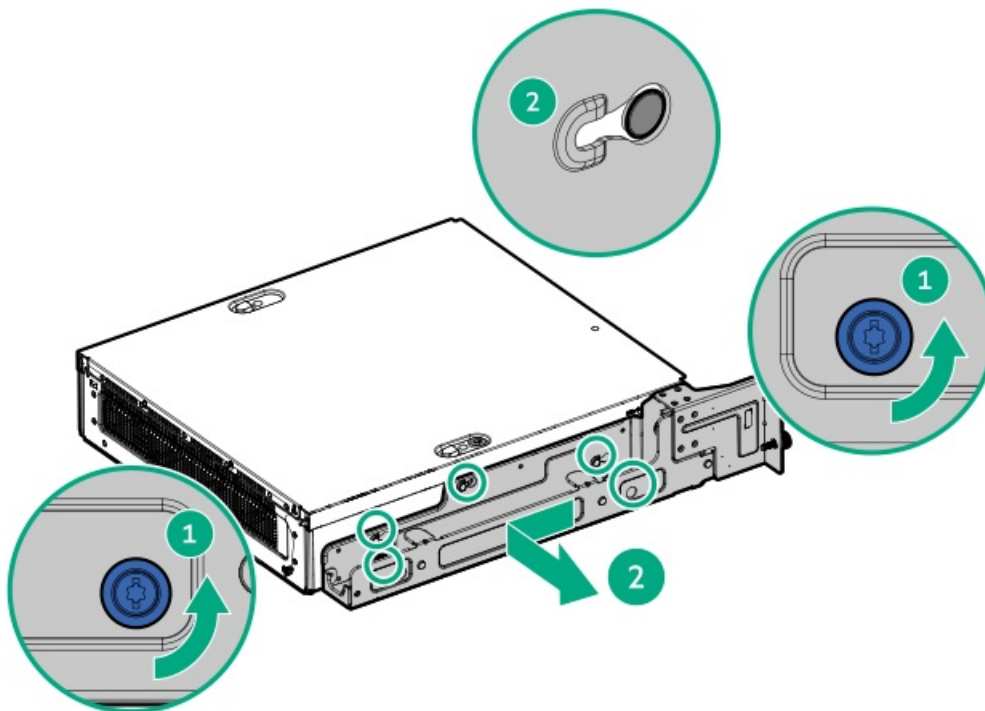

## Results

The removal procedure is complete. To replace the component, reverse this procedure.



# Removing and replacing the two-post rack support brackets

## Prerequisites

-  **IMPORTANT**  
Get help to lift and stabilize the server during removal from the rack. **If the server is installed higher than chest level, additional two people might be required to help remove the server:** One person to support the server weight, and the other two to slide the server out of the rack.
- Before you perform this procedure, make sure that you have a T-25 Torx screwdriver available.

## About this task

The two-post rack support brackets are secured to the rack by eight screws fastened to the rack columns. There are no rack rails supporting this server in a two-post rack.

## Procedure

1. If installed, remove the front bezel.
2. Power down the server.
3. Remove all power:
  - a. Disconnect each power cord from the power source.
  - b. Disconnect each power cord from the server.
4. Disconnect all peripheral cables from the server.
5. Remove the server from the two-post rack.
6. Place the server on a flat, level work surface.
7. Remove the right two-post rack support bracket:
  - a. Remove the screws from the back bracket. Slide the back bracket toward the back to release it from the rack column.

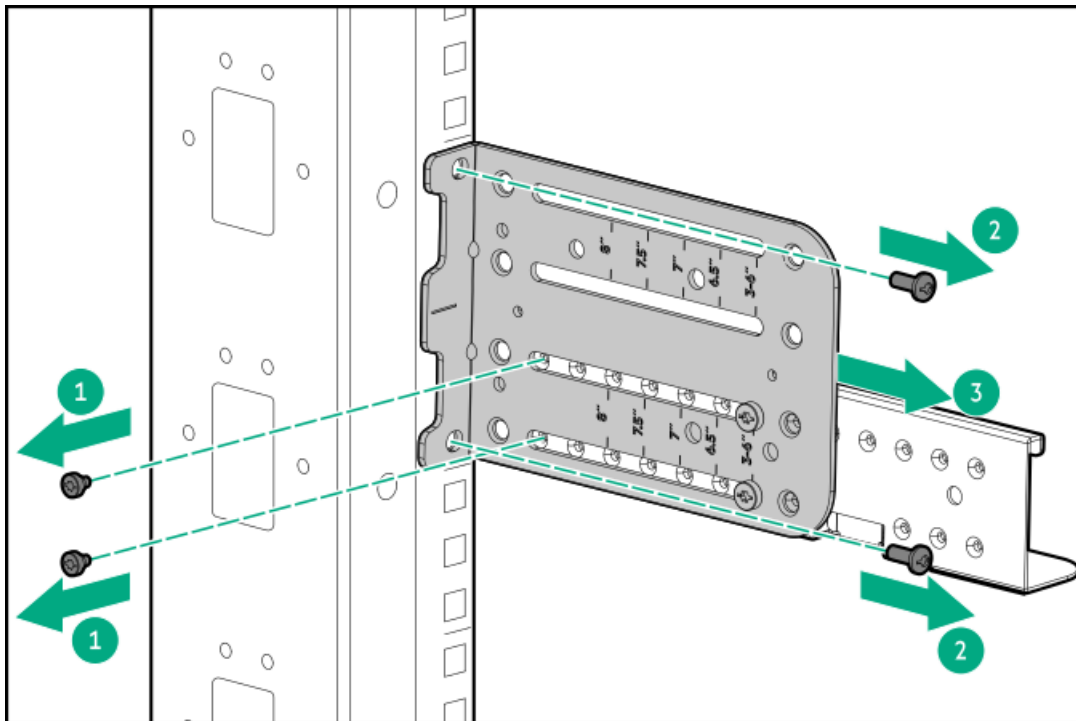

b. Support the bracket while removing the screws from the front bracket.

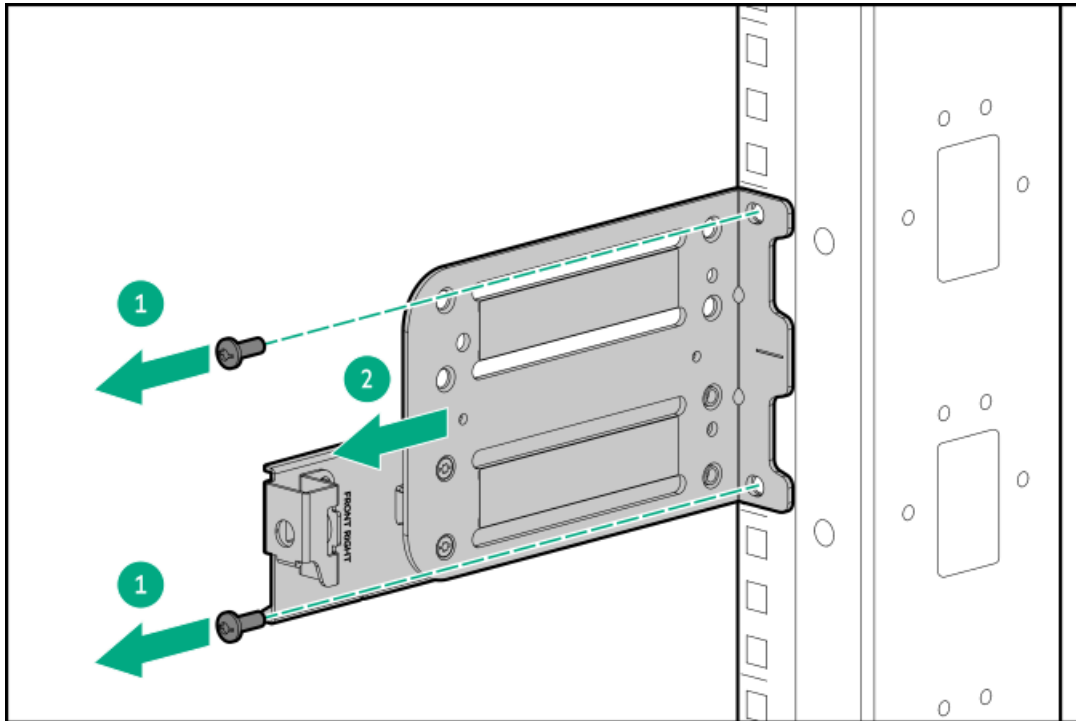

8. Repeat step 7 to remove the left support bracket.

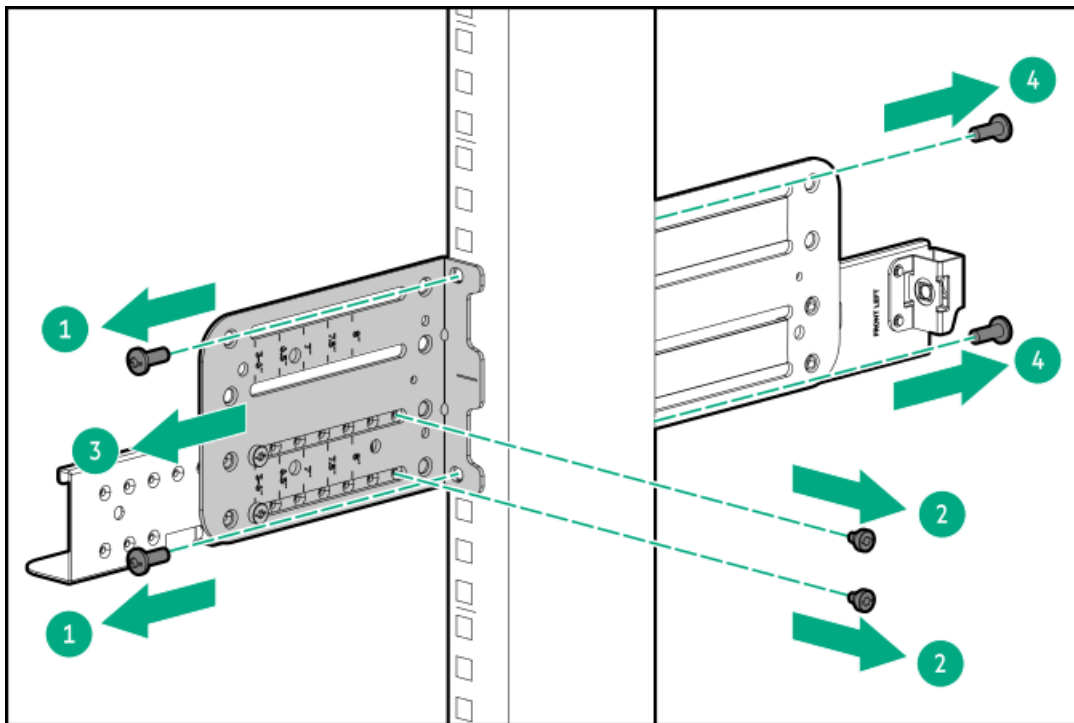

## Results

The removal procedure is complete. To replace the component, reverse this procedure.

## Removing and replacing a fan

### About this task



#### CAUTION

To maintain proper system cooling, do not operate the server for long period with the access panel open or removed. Operating the server in this manner results in an improper system airflow. For internal hot-plug component procedures, complete the procedure within 60 seconds. Failure to do so can cause the system temperature to increase and trip the safety threshold. When this happens:

- The health LED flashes amber.
- The operating system gracefully shuts down.



#### CAUTION

To prevent improper cooling and thermal damage, do not operate the server unless all bays are populated with either a component or a blank.



#### IMPORTANT

The fan setup can either be standard, single-rotor fans or high performance, dual-rotor fans. Do not mix fan types in the same server.

## Procedure

1. Extend the server from the rack.
2. Remove the access panel.
3. Remove the fan:
  - a. Press and hold the latch.
  - b. Lift the fan from the fan cage.

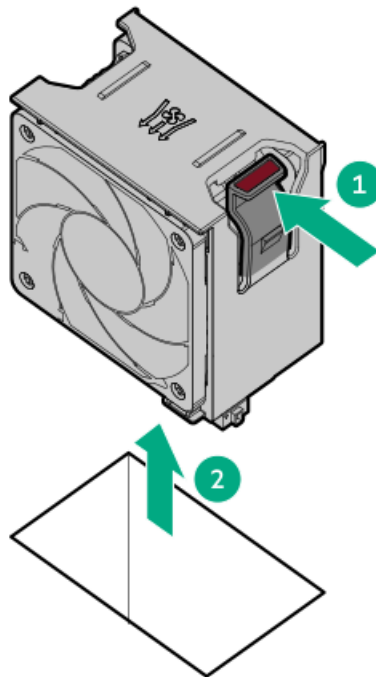

## Results

The removal procedure is complete. To replace the component, reverse this procedure.

# Removing and replacing a DIMM

## About this task

[https://sketchfab.com/models/ec39e4183f8f410e93c8c34a1611b560/embed?ui\\_infos=0&ui\\_watermark=0&ui\\_help=0&ui\\_vr=0&ui\\_settings=0&ui\\_inspector=0&ui\\_hint=2&ui\\_animations=0&ui\\_color=01a982&ui\\_theme=dark&autostart=1&camera=0](https://sketchfab.com/models/ec39e4183f8f410e93c8c34a1611b560/embed?ui_infos=0&ui_watermark=0&ui_help=0&ui_vr=0&ui_settings=0&ui_inspector=0&ui_hint=2&ui_animations=0&ui_color=01a982&ui_theme=dark&autostart=1&camera=0)



### CAUTION

Before replacing a DIMM, backplane, expansion card, riser board, or other similar PCA components due to a perceived hardware error, make sure first that the component is firmly seated in the slot.

When installing the replacement component:

- Observe antistatic precautions.
- Handle the PCA only along the edges.
- Do not touch the components and connectors on the PCA.
- Do not bend or flex the PCA.

## Procedure

1. Back up all server data.
2. If installed, remove the front bezel.
3. Power down the server.
4. Remove all power:
  - a. Disconnect each power cord from the power source.
  - b. Disconnect each power cord from the server.
5. Disconnect all peripheral cables from the server.
6. Remove the server from a four-post rack.
7. Place the server on a flat, level work surface.
8. Remove the access panel.
9. Remove the air baffle.
10. Remove the DIMM.
  - a. Open the DIMM slot latches.
  - b. Lift the DIMM out of the slot.

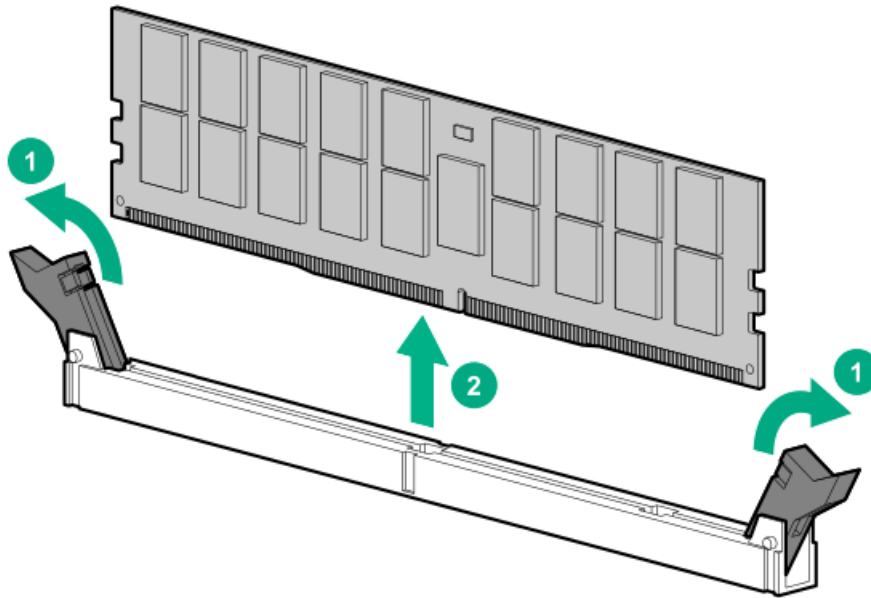

## Results

The removal procedure is complete. To replace the component, reverse this procedure.

## Removing and replacing the 2 SFF drive cage

### Prerequisites

Before you perform this procedure, make sure that you have the following items available:

- T-10 Torx screwdriver
- T-15 Torx screwdriver

### About this task



#### CAUTION

A discharge of static electricity from a finger or other conductor might damage system boards or other static-sensitive devices. To prevent damage, observe [antistatic precautions](#).



#### CAUTION

To prevent improper cooling and thermal damage, do not operate the server unless all bays are populated with either a component or a blank.

### Procedure

1. [Back up all server data](#).
2. If installed, [remove the front bezel](#).
3. [Power down the server](#).
4. Remove all power:
  - a. Disconnect each power cord from the power source.
  - b. Disconnect each power cord from the server.

5. Disconnect all peripheral cables from the server.
6. Remove the server from a four-post rack.
7. Place the server on a flat, level work surface.
8. Remove the access panel.
9. Remove the air baffle.

**Removing the 2 SFF drive cage**

10. Remove the drives.

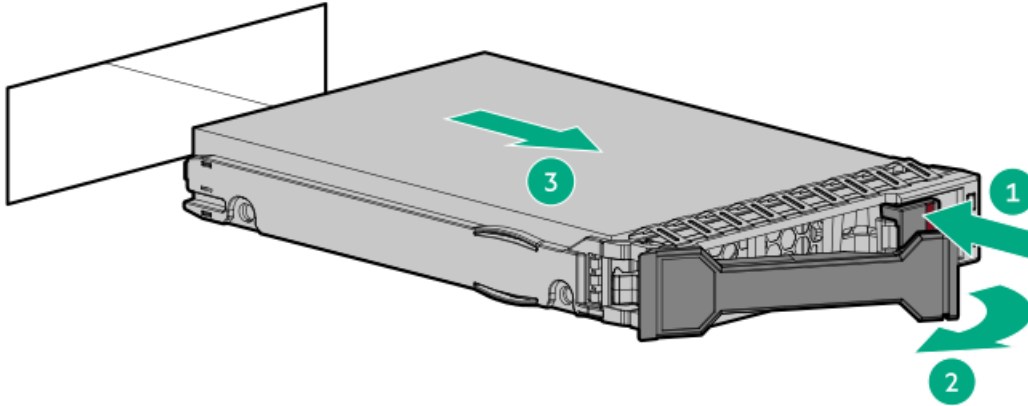

11. Disconnect the 2 SFF signal and power cables from the drive backplane.
12. Remove the drive cage blank screw, and then slide the blank out of the drive cage.

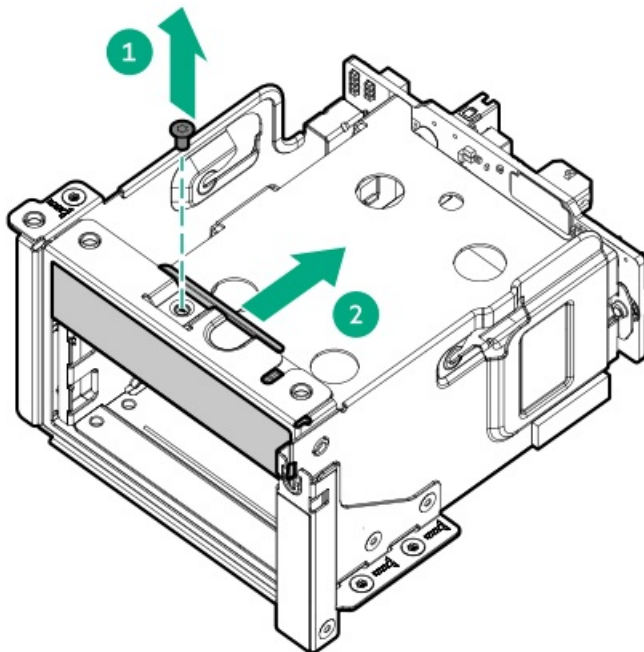

13. Remove the 2 SFF drive cage:

- a. Remove the screws.

Retain the screws and grommets. The screws will be used to secure the new drive cage assembly.

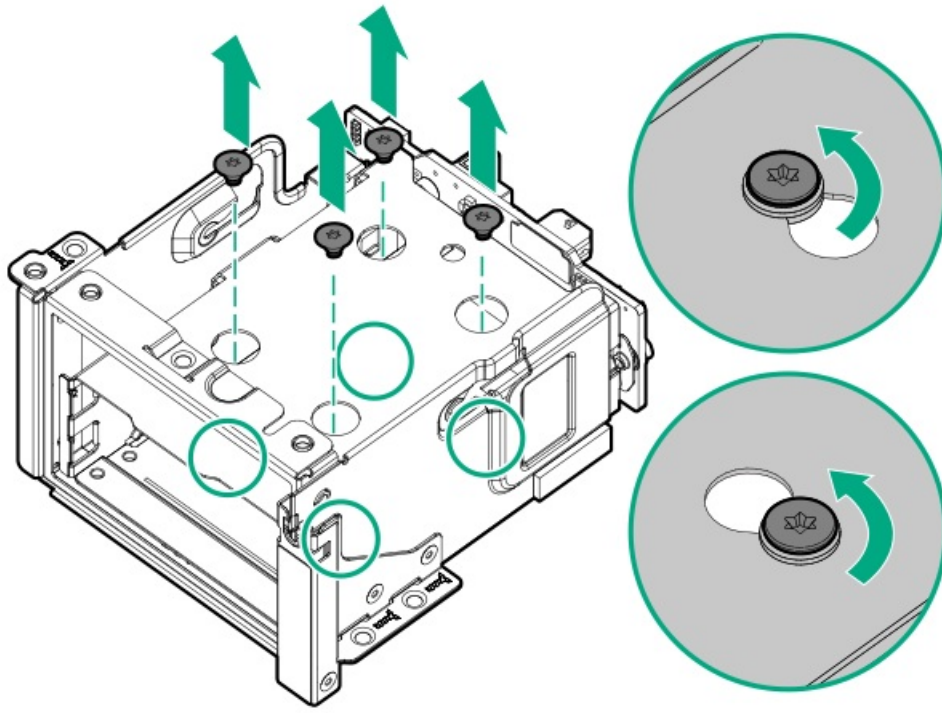

b. Slide the drive cage backward, and then lift it out of the drive base cage.

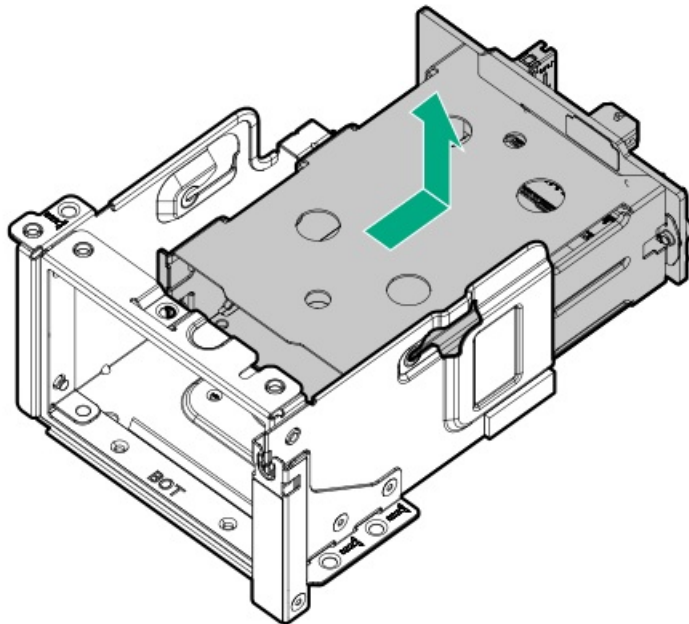

14. Loosen the backplane screws to remove the backplane.



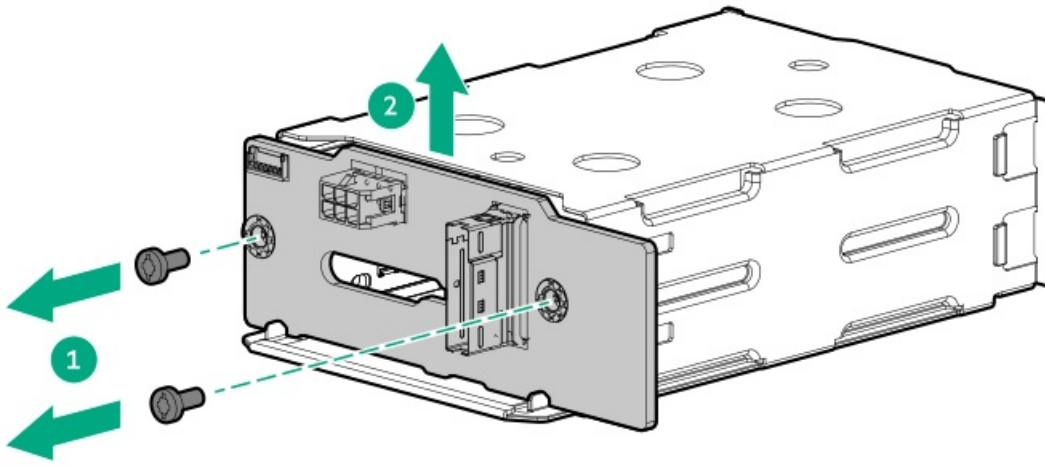

## Results

The removal procedure is complete. To replace the component, reverse this procedure.

## Removing and replacing the E3.S drive cage

### Prerequisites

Before you perform this procedure, make sure that you have the following items available:

- T-10 Torx screwdriver
- T-15 Torx screwdriver
- Small slotted screwdriver—This tool is required only if the E3.S drive cage fillers are to be removed.

### About this task



#### CAUTION

A discharge of static electricity from a finger or other conductor might damage system boards or other static-sensitive devices. To prevent damage, observe [antistatic precautions](#).



#### CAUTION

To prevent improper cooling and thermal damage, do not operate the server unless all bays are populated with either a component or a blank.

### Procedure

1. [Back up all server data](#).
2. If installed, [remove the front bezel](#).
3. [Power down the server](#).
4. Remove all power:
  - a. Disconnect each power cord from the power source.
  - b. Disconnect each power cord from the server.
5. Disconnect all peripheral cables from the server.
6. [Remove the server from a four-post rack](#).

7. Place the server on a flat, level work surface.

8. Remove the access panel.

9. Remove the air baffle.

### Removing the E3.S drive cage

10. Remove the drives.

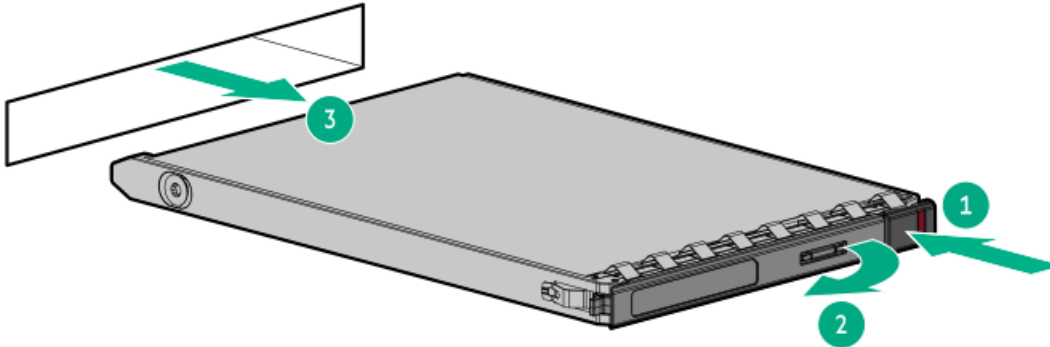

11. Remove the E3.S drive cage fillers:

a. Insert a small-slotted screwdriver into the slot on the far left to push the release latch.

b. Remove the E3.S drive cage filler.

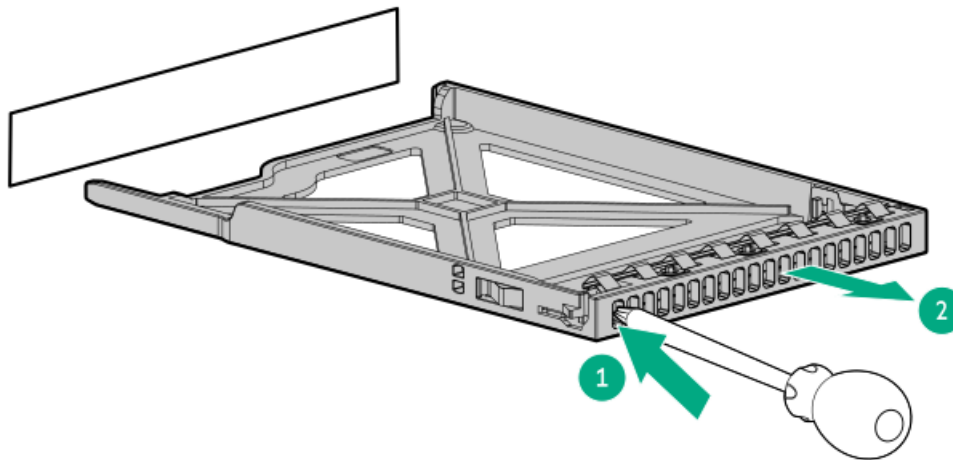

12. Disconnect the 4 E3.S drive signal and power cables from the drive backplane.

13. Remove the 4 E3.S drive cage:

a. Remove the screws.

Retain all screws for future use.

b. Slide the 4 E3.S drive cage backward and then lift it out of the drive base cage.

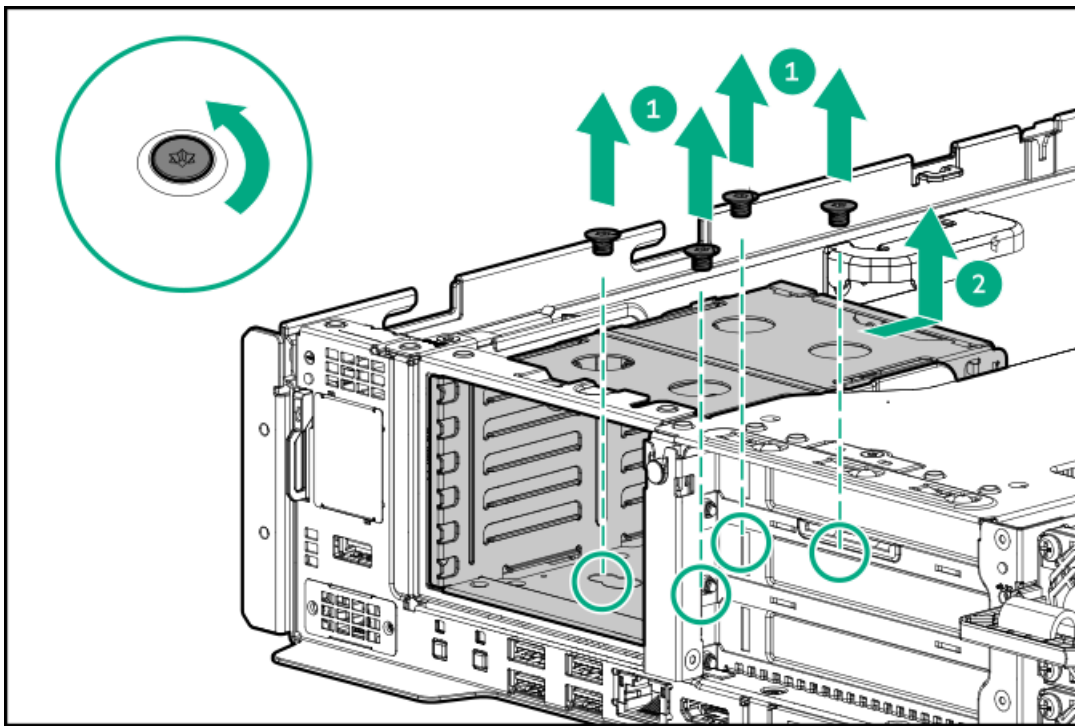

14. Remove the screw from the 2 E3.S cable connector bracket, and then pivot the bracket upward to remove it from the drive cage. Retain the screw and bracket for future use.

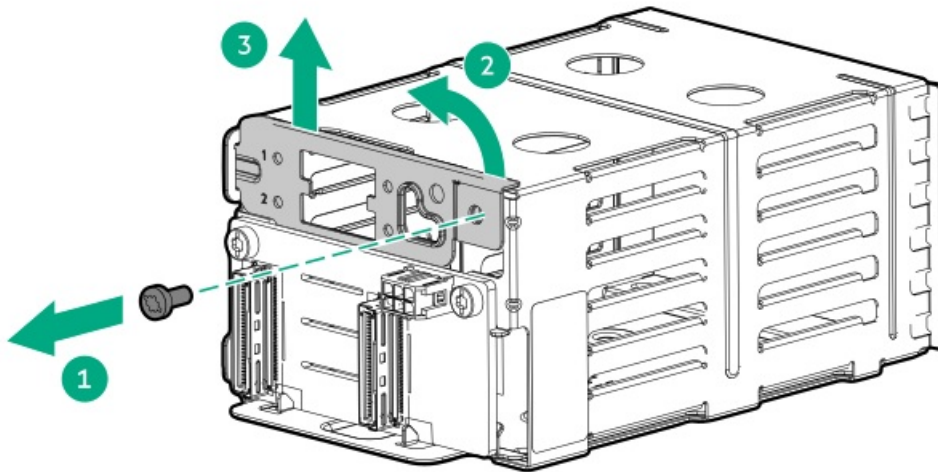

15. Loosen the backplane screws to remove the backplane.

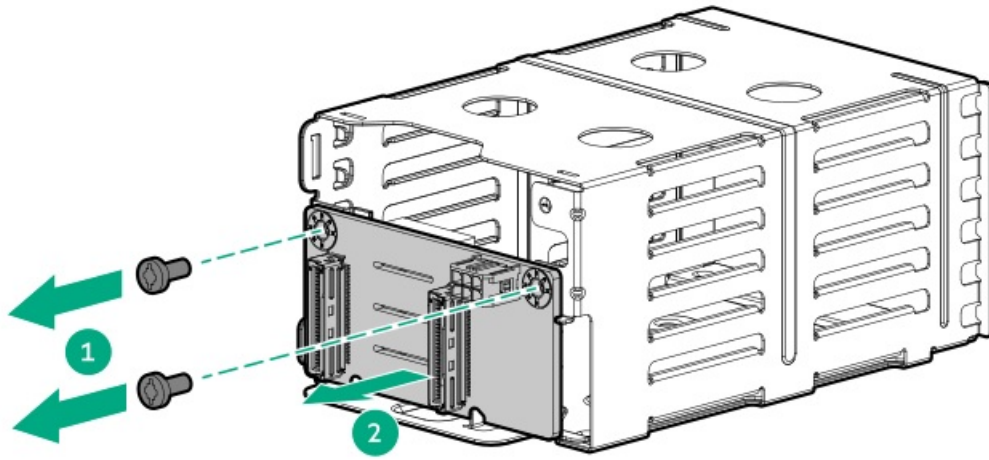

## Results

The removal procedure is complete. To replace the component, reverse this procedure.

## Removing and replacing the 6 E3.S enablement cable on the E3.S drive cage

### Prerequisites

Before you perform this procedure, make sure that you have the following items available:

- T-10 Torx screwdriver
- T-15 Torx screwdriver
- Phillips No. 1 screwdriver

### About this task



#### CAUTION

A discharge of static electricity from a finger or other conductor might damage system boards or other static-sensitive devices. To prevent damage, observe [antistatic precautions](#).



#### CAUTION

To prevent improper cooling and thermal damage, do not operate the server unless all bays are populated with either a component or a blank.

### Procedure

1. [Back up all server data](#).
2. If installed, [remove the front bezel](#).
3. [Power down the server](#).
4. Remove all power:
  - a. Disconnect each power cord from the power source.
  - b. Disconnect each power cord from the server.
5. Disconnect all peripheral cables from the server.

6. Remove the server from a four-post rack.
7. Place the server on a flat, level work surface.
8. Remove the access panel.
9. Remove the air baffle.
10. Remove the drives.

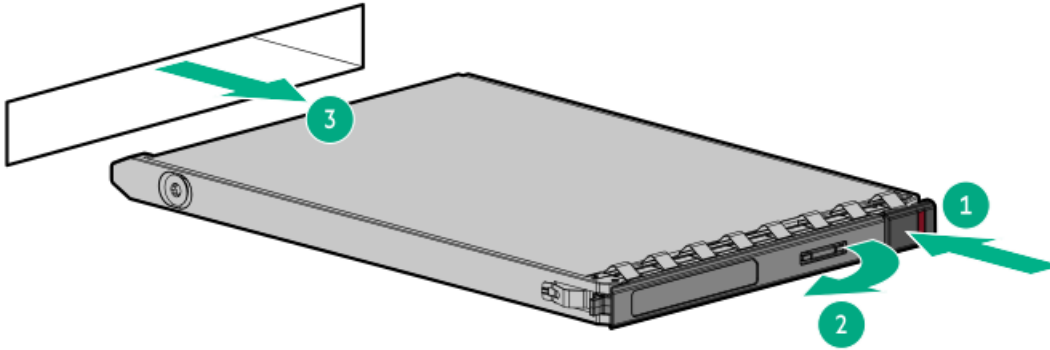

11. Disconnect the following cables from the system board:

- a. 4 E3.S signal cable
- b. 2 E3.S signal cable
- c. Drive power cable

12. Remove the E3.S drive cage:

- a. Remove the screws.

Retain all screws for future use.

- b. Slide the E3.S drive cage backward and then lift it out of the drive base cage.

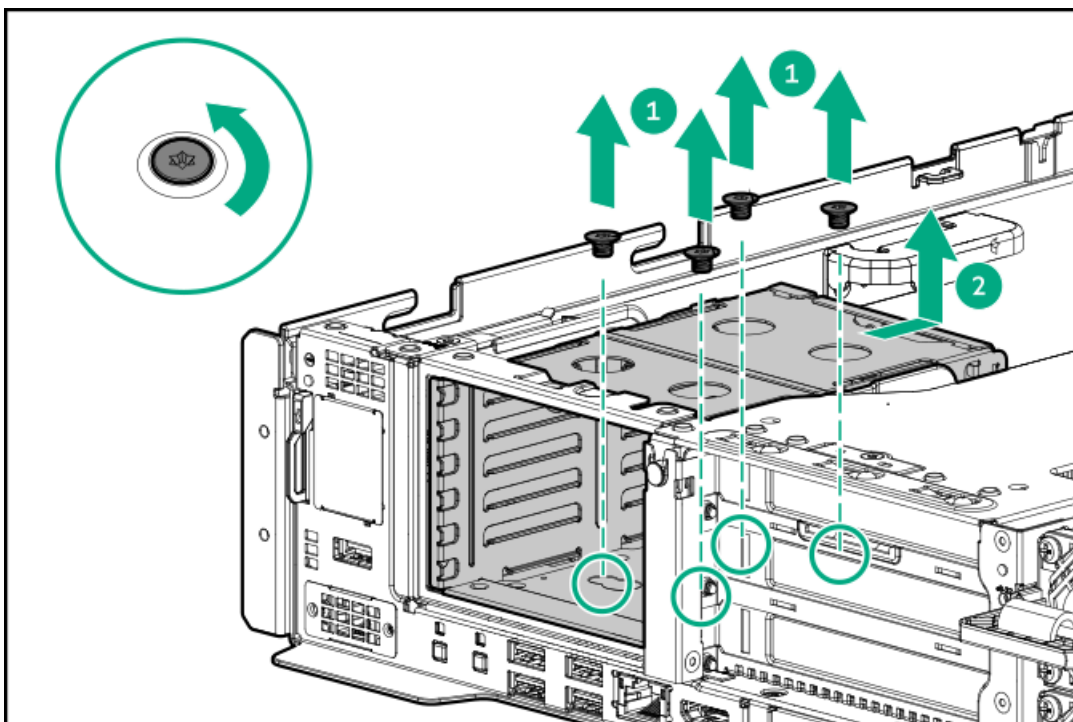

13. Remove the screw from the 2 E3.S cable connector bracket, and then pivot the bracket upward to remove the cable and the bracket from

the drive cage.

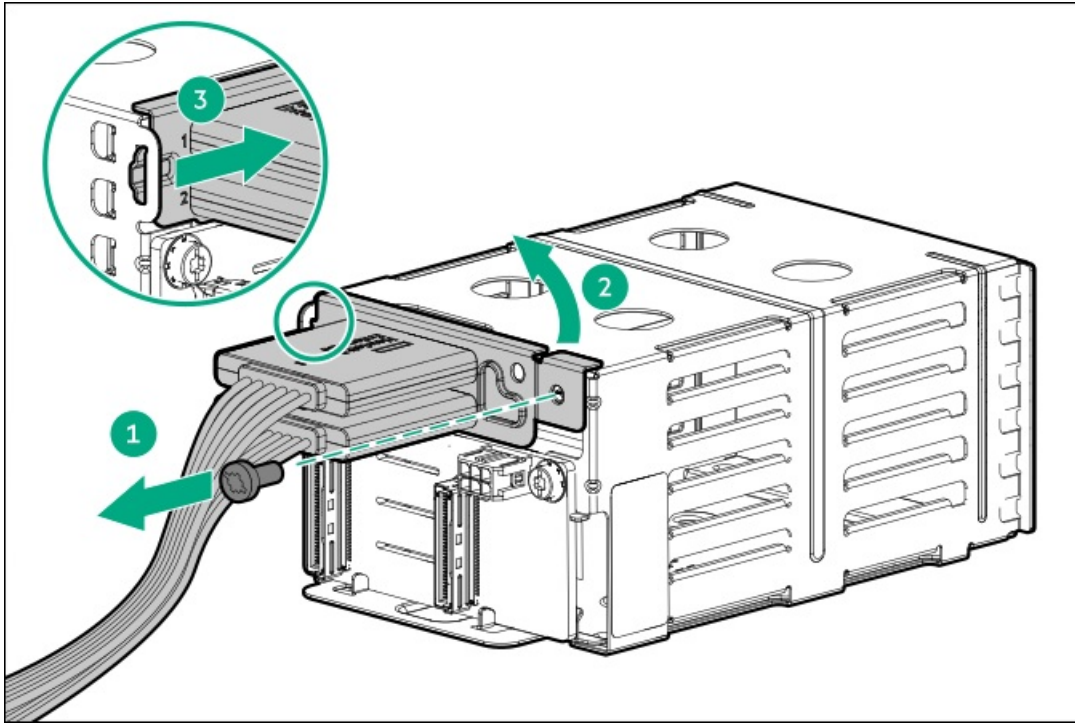

14. Remove the screws from the bracket, and then remove the 6 E3.S enablement cable.

Retain the bracket and screws for future use.

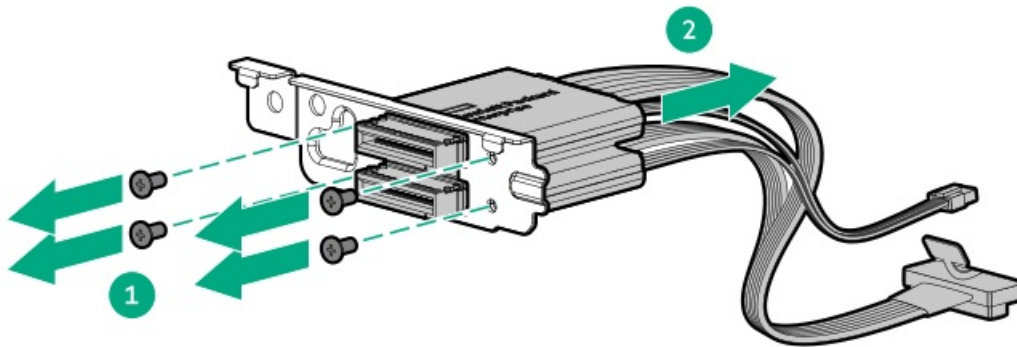

## Results

The removal procedure is complete. To replace the component, reverse this procedure.

## Drive backplane replacement

### Subtopics

[Removing and replacing the 2 SFF drive backplane](#)

[Removing and replacing the 4 E3.S drive backplane](#)

## Removing and replacing the 2 SFF drive backplane

## Prerequisites

Before you perform this procedure, make sure that you have the following items available:

- T-10 Torx screwdriver
- T-15 Torx screwdriver

## About this task



### CAUTION

Before replacing a DIMM, backplane, expansion card, riser board, or other similar PCA components due to a perceived hardware error, make sure first that the component is firmly seated in the slot.

When installing the replacement component:

- Observe antistatic precautions.
- Handle the PCA only along the edges.
- Do not touch the components and connectors on the PCA.
- Do not bend or flex the PCA.



### CAUTION

To prevent improper cooling and thermal damage, do not operate the server unless all bays are populated with either a component or a blank.

## Procedure

1. Back up all server data.
2. If installed, remove the front bezel.
3. Power down the server.
4. Remove all power:
  - a. Disconnect each power cord from the power source.
  - b. Disconnect each power cord from the server.
5. Disconnect all peripheral cables from the server.
6. Remove the server from a four-post rack.
7. Place the server on a flat, level work surface.
8. Remove the access panel.
9. Remove the air baffle.

### Removing the 2 SFF drive backplane

10. Remove the drives.

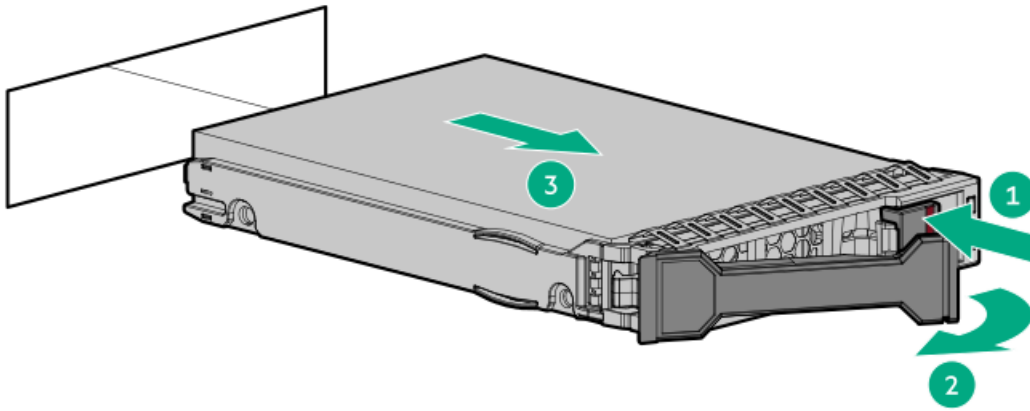

11. Disconnect the 2 SFF signal and power cables from the drive backplane.
12. Remove the drive cage blank screw, and then slide the blank out of the drive cage.

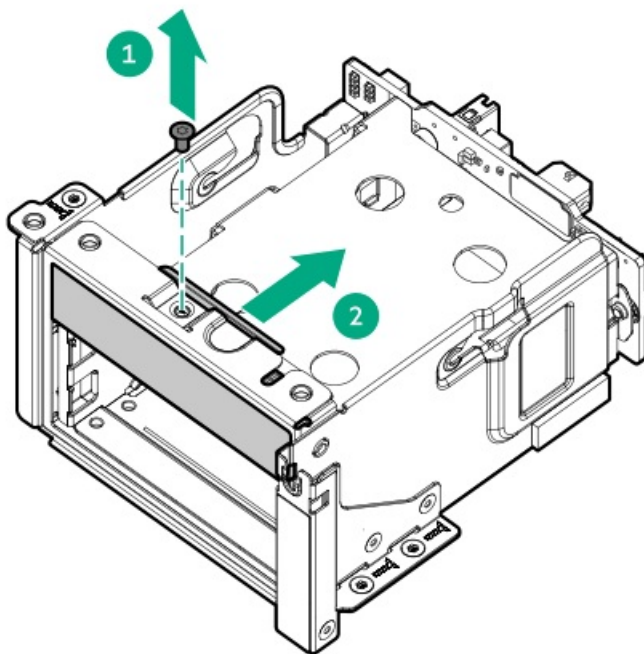

13. Remove the 2 SFF drive cage:
  - a. Remove the screws.

Retain the screws and grommets. The screws will be used to secure the new drive cage assembly.



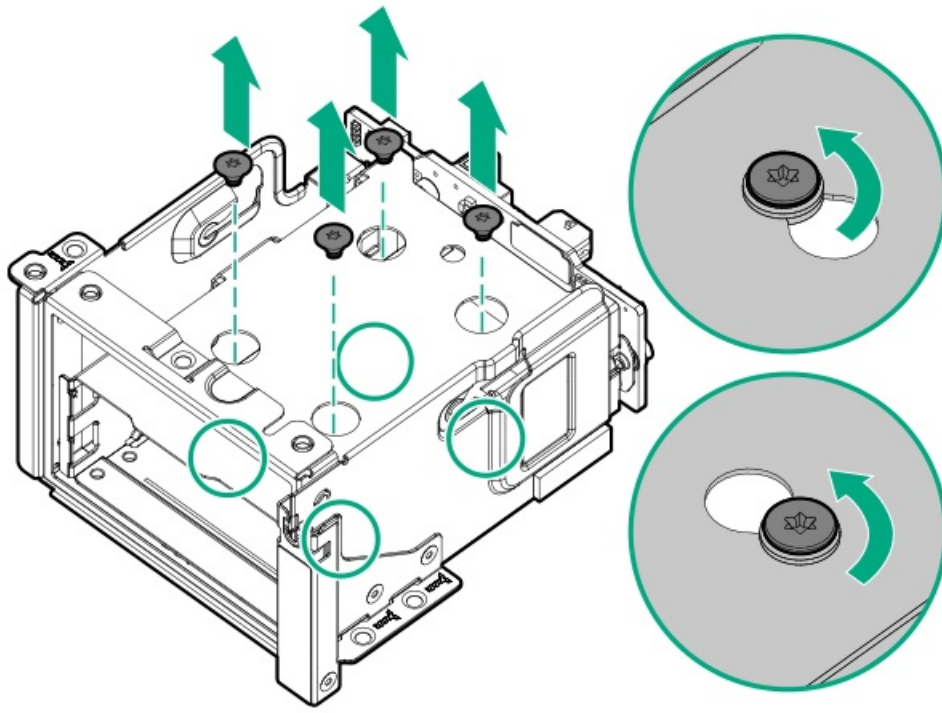

b. Slide the drive cage backward, and then lift it out of the drive base cage.

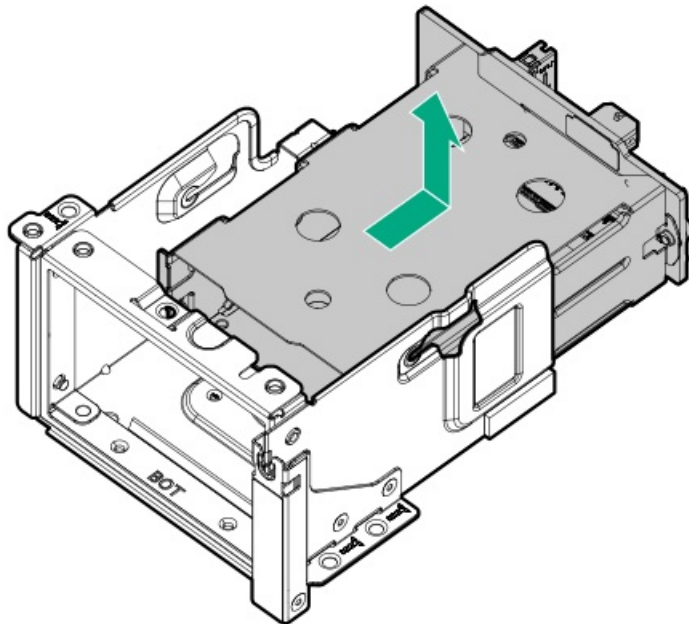

14. Loosen the backplane screws to remove the backplane.

Retain the screws. These screws will be used to secure the new spare backplane.



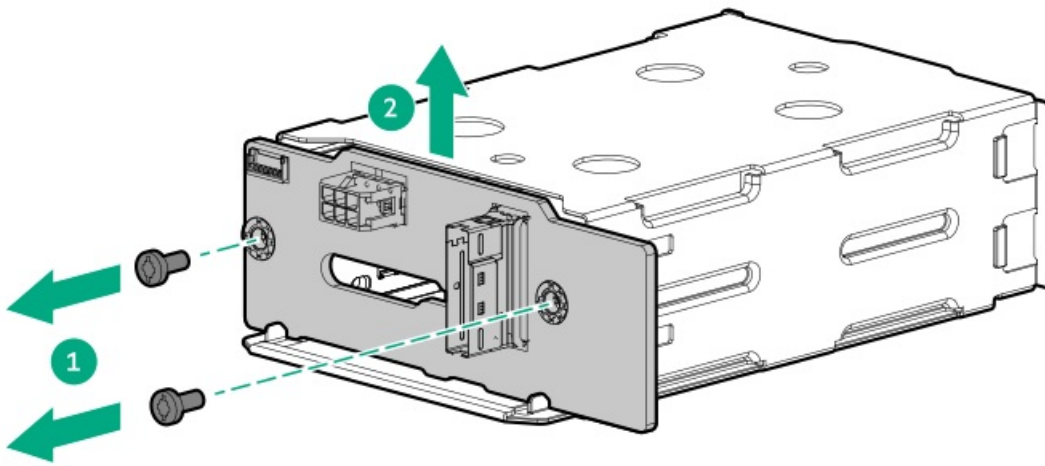

## Results

The removal procedure is complete. To replace the component, reverse this procedure.

## Removing and replacing the 4 E3.S drive backplane

### Prerequisites

Before you perform this procedure, make sure that you have the following items available:

- T-10 Torx screwdriver
- T-15 Torx screwdriver
- Small slotted screwdriver—This tool is required only if the E3.S drive cage fillers are to be removed.

### About this task



#### CAUTION

Before replacing a DIMM, backplane, expansion card, riser board, or other similar PCA components due to a perceived hardware error, make sure first that the component is firmly seated in the slot.

When installing the replacement component:

- Observe antistatic precautions.
- Handle the PCA only along the edges.
- Do not touch the components and connectors on the PCA.
- Do not bend or flex the PCA.



#### CAUTION

To prevent improper cooling and thermal damage, do not operate the server unless all bays are populated with either a component or a blank.

### Procedure

1. Back up all server data.
2. If installed, remove the front bezel.
3. Power down the server.

4. Remove all power:
  - a. Disconnect each power cord from the power source.
  - b. Disconnect each power cord from the server.
5. Disconnect all peripheral cables from the server.
6. Remove the server from a four-post rack.
7. Place the server on a flat, level work surface.
8. Remove the access panel.
9. Remove the air baffle.

**Removing the 4 E3.S drive backplane**

10. Remove the drives.

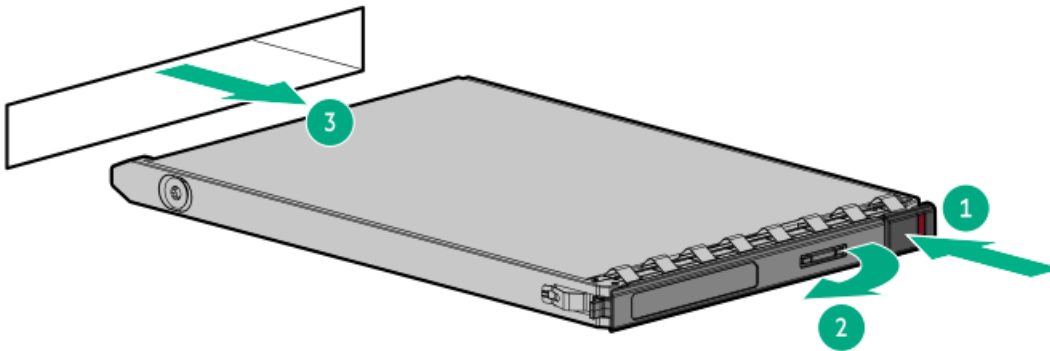

11. Remove the E3.S drive cage fillers:
  - a. Insert a small-slotted screwdriver into the slot on the far left to push the release latch.
  - b. Remove the E3.S drive cage filler.

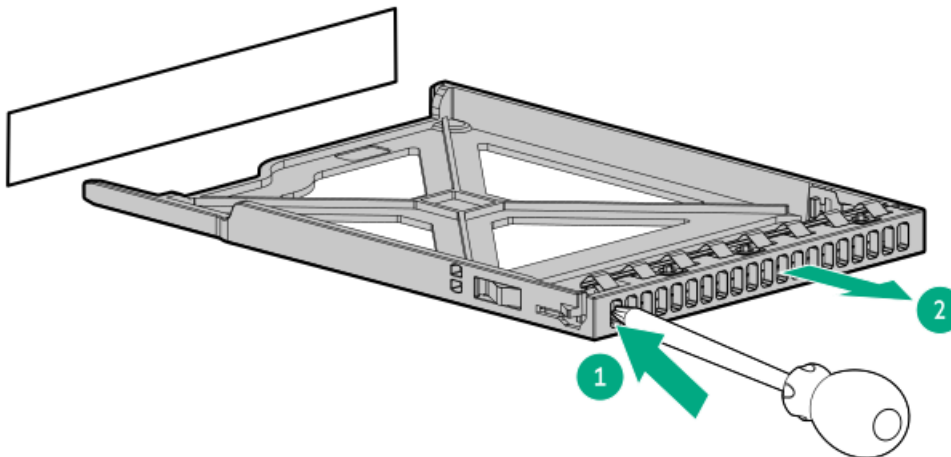

12. Disconnect the 4 E3.S drive signal and power cables from the drive backplane.

13. Remove the 4 E3.S drive cage:

- a. Remove the screws.
 

Retain all screws for future use.
- b. Slide the 4 E3.S drive cage backward and then lift it out of the drive base cage.

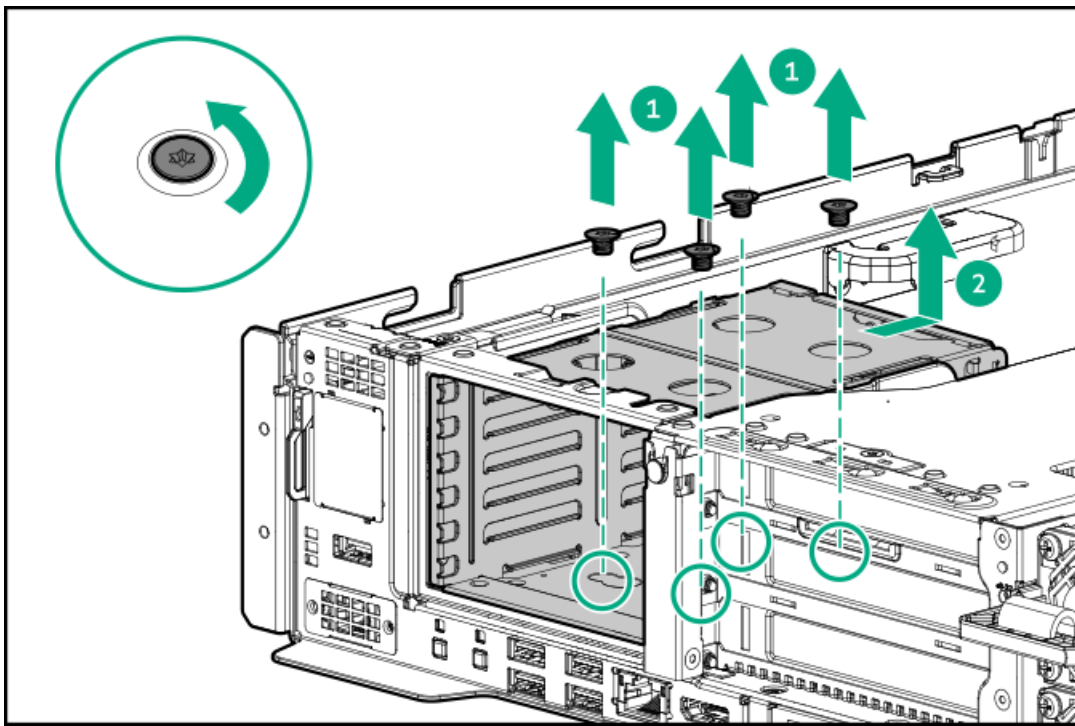

14. Remove the screw from the 2 E3.S cable connector bracket, and then pivot the bracket upward to remove it from the drive cage. Retain the screw and bracket for future use.

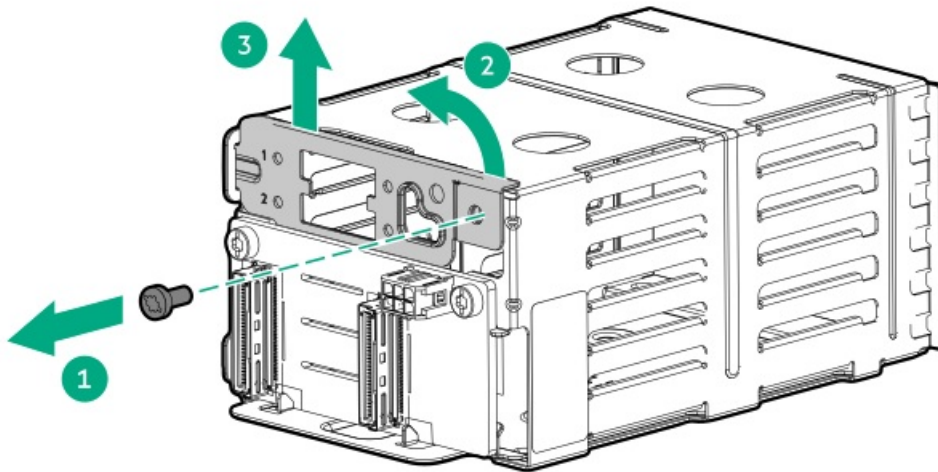

15. Loosen the backplane screws to remove the backplane. Retain the screws. These screws will be used to secure the new spare backplane.

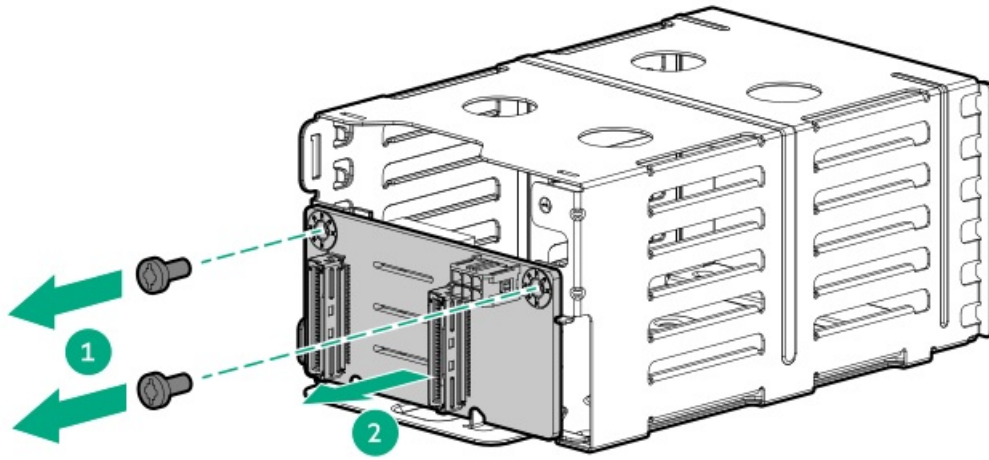

## Results

The removal procedure is complete. To replace the component, reverse this procedure.

## Expansion card replacement

### Subtopics

[Removing and replacing an expansion card in the three-slot riser cage](#)

## Removing and replacing an expansion card in the three-slot riser cage

### Prerequisites

Before you perform this procedure, make sure that you have a T-10 Torx screwdriver available.

### About this task



#### CAUTION

To prevent improper cooling and thermal damage, do not operate the server unless all PCIe slots have either a riser slot blank or an expansion card installed.



#### CAUTION

Before replacing a DIMM, backplane, expansion card, riser board, or other similar PCA components due to a perceived hardware error, make sure first that the component is firmly seated in the slot.

When installing the replacement component:

- Observe antistatic precautions.
- Handle the PCA only along the edges.
- Do not touch the components and connectors on the PCA.
- Do not bend or flex the PCA.

### Procedure

1. If installed, remove the front bezel.
2. Power down the server.
3. Remove all power:
  - a. Disconnect each power cord from the power source.
  - b. Disconnect each power cord from the server.
4. Disconnect all peripheral cables from the server.
5. Remove the server from a four-post rack.
6. Place the server on a flat, level work surface.
7. Remove the access panel.
8. If stacking risers are installed in PCIe slots 1-2, do the following:
  - a. Remove the air baffle.
  - b. Disconnect the stacking riser cables from the system board.
9. Disconnect any internal cables that are connected to the expansion card.
10. Remove the three-slot riser cage:
  - a. Release the half-turn spring latches.
  - b. Use the blue touchpoints on both sides to lift the riser cage off the system board.

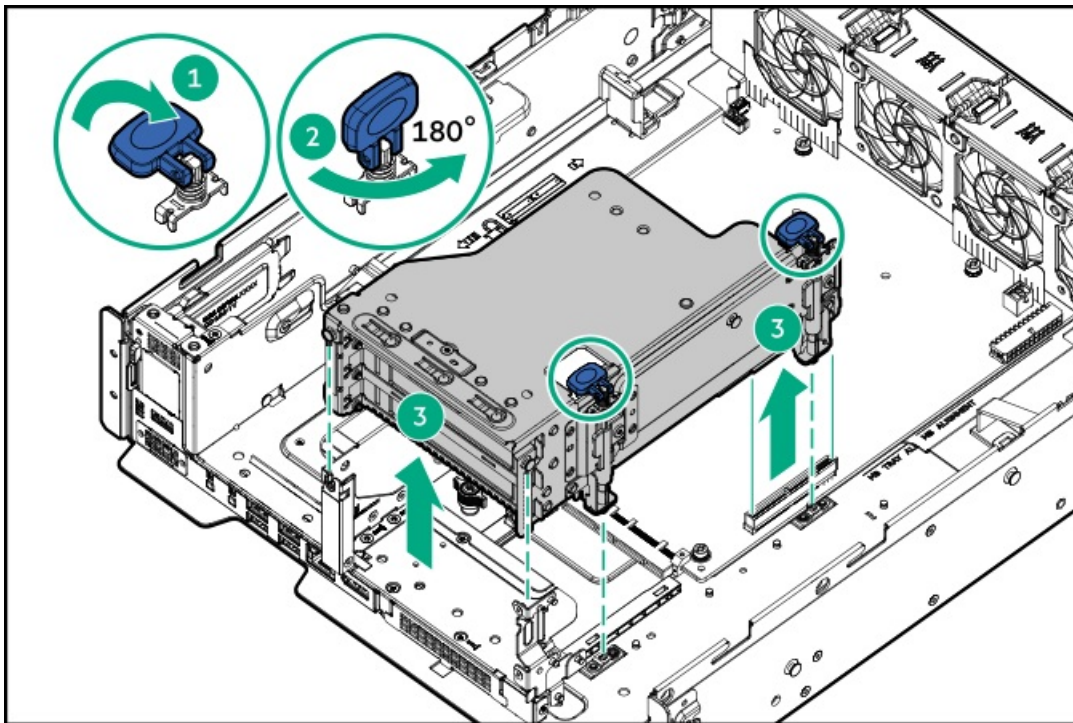

11. Remove the expansion card:
  - a. Remove the screw.
  - b. Press and hold the release latch.
  - c. Remove the expansion card.

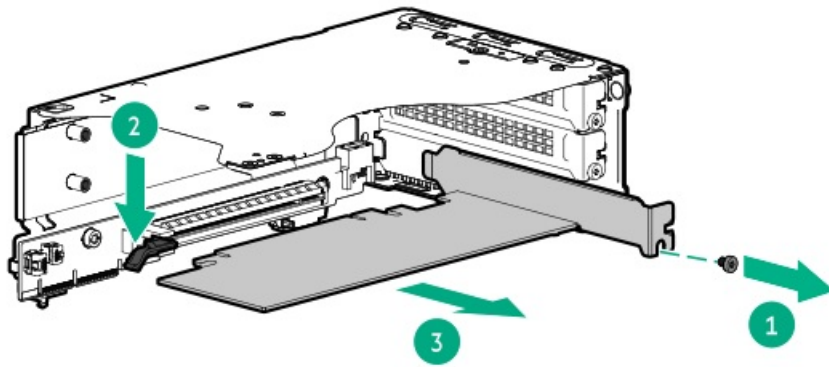

## Results

The removal procedure is complete. To replace the component, reverse this procedure.

## Removing and replacing a type-o storage controller

### About this task



#### CAUTION

The port blank provides EMI shielding and helps maintain proper thermal status inside the server. Do not operate the server when a port blank is removed without the corresponding I/O port option installed.



#### CAUTION

Before replacing a DIMM, backplane, expansion card, riser board, or other similar PCA components due to a perceived hardware error, make sure first that the component is firmly seated in the slot.

When installing the replacement component:

- Observe antistatic precautions.
- Handle the PCA only along the edges.
- Do not touch the components and connectors on the PCA.
- Do not bend or flex the PCA.

## Procedure

1. If installed, remove the front bezel.
2. Power down the server.
3. Remove all power:
  - a. Disconnect each power cord from the power source.
  - b. Disconnect each power cord from the server.
4. Disconnect all peripheral cables from the server.
5. Remove the server from a four-post rack.
6. Place the server on a flat, level work surface.

7. Remove the access panel.
8. If stacking risers are installed in PCIe slots 1–2, do the following:
  - a. Remove the air baffle.
  - b. Disconnect the stacking riser cables from the system board.
9. If an expansion card with internal cables is installed on the riser, disconnect the cables from the card.
10. Remove the three-slot riser cage:
  - a. Release the half-turn spring latches.
  - b. Use the blue touchpoints on both sides to lift the riser cage off the system board.

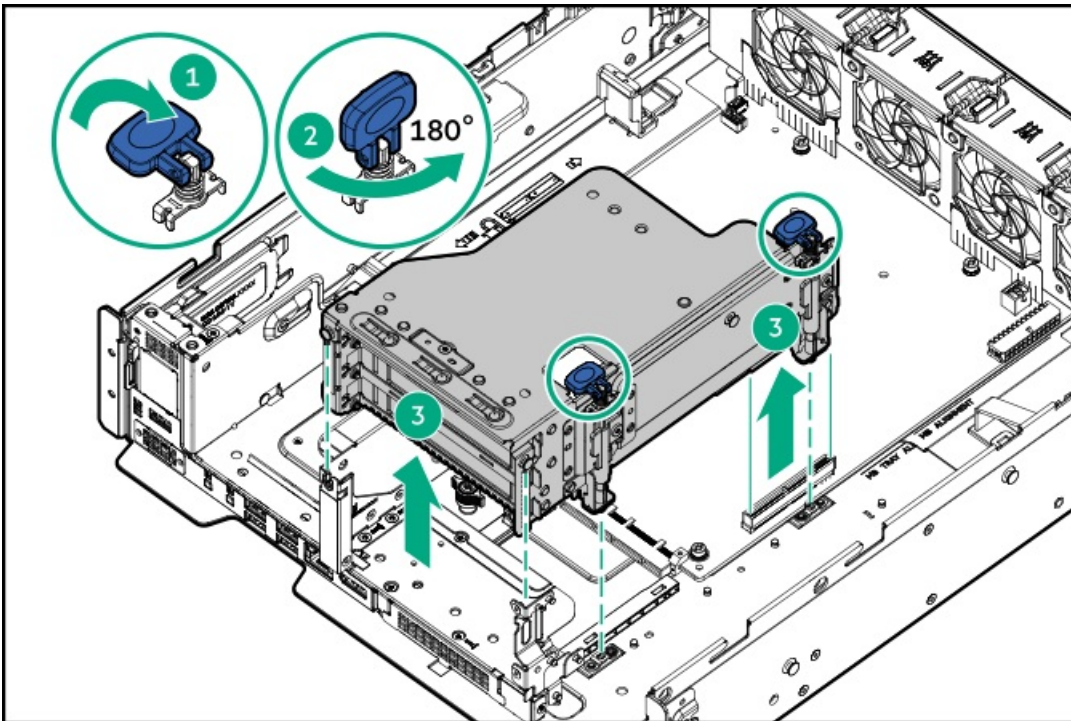

11. Disconnect the storage cables from the type-o controller.
12. Remove the type-o storage controller:
  - a. Rotate the locking pin to the open (vertical) position.
  - b. Slide the controller out of the bay.

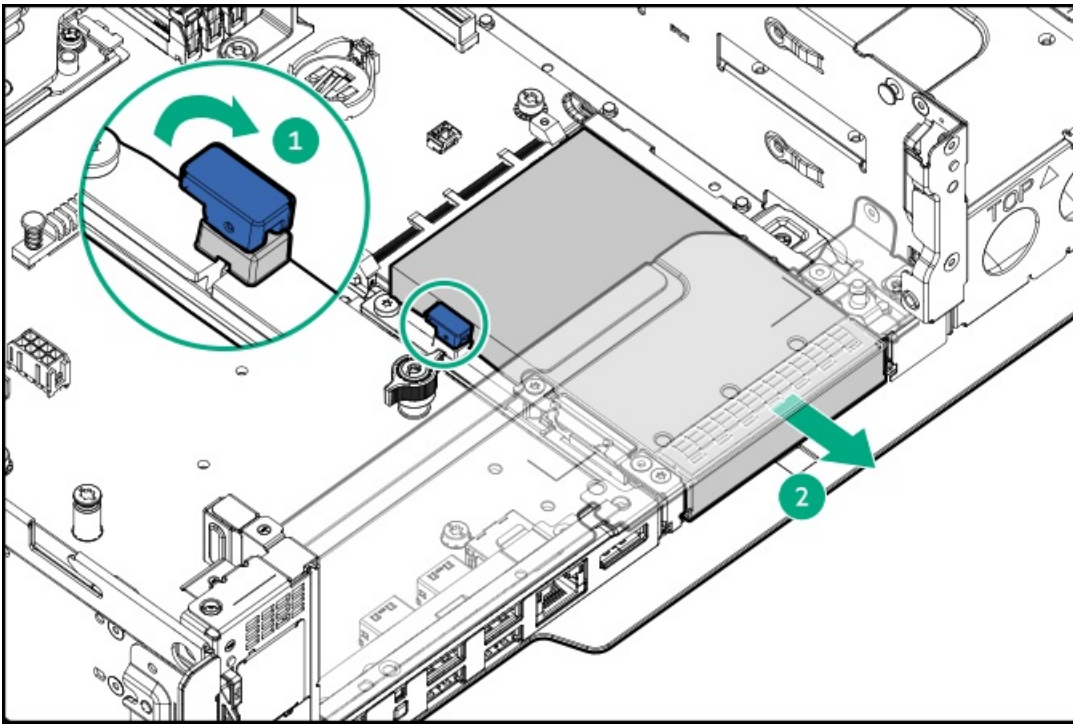

## Results

The removal procedure is complete. To replace the component, reverse this procedure.

## Riser board replacement

### Subtopics

[Removing and replacing the base riser in the three-slot riser cage](#)

[Removing and replacing a stacking riser in the three-slot riser cage](#)

## Removing and replacing the base riser in the three-slot riser cage

### Prerequisites

Before you perform this procedure, make sure that you have a T-15 Torx screwdriver available.

### About this task



#### CAUTION

To prevent improper cooling and thermal damage, do not operate the server unless all PCIe slots have either a riser slot blank or an expansion card installed.



### CAUTION

Before replacing a DIMM, backplane, expansion card, riser board, or other similar PCA components due to a perceived hardware error, make sure first that the component is firmly seated in the slot.

When installing the replacement component:

- Observe antistatic precautions.
- Handle the PCA only along the edges.
- Do not touch the components and connectors on the PCA.
- Do not bend or flex the PCA.

## Procedure

1. If installed, remove the front bezel.
2. Power down the server.
3. Remove all power:
  - a. Disconnect each power cord from the power source.
  - b. Disconnect each power cord from the server.
4. Disconnect all peripheral cables from the server.
5. Remove the server from a four-post rack.
6. Place the server on a flat, level work surface.
7. Remove the access panel.
8. If stacking risers are installed in PCIe slots 1–2, do the following:
  - a. Remove the air baffle.
  - b. Disconnect the stacking riser cables from the system board.
9. If an expansion card with internal cables is installed on the riser, disconnect the cables from the card.
10. Remove the three-slot riser cage:
  - a. Release the half-turn spring latches.
  - b. Use the blue touchpoints on both sides to lift the riser cage off the system board.

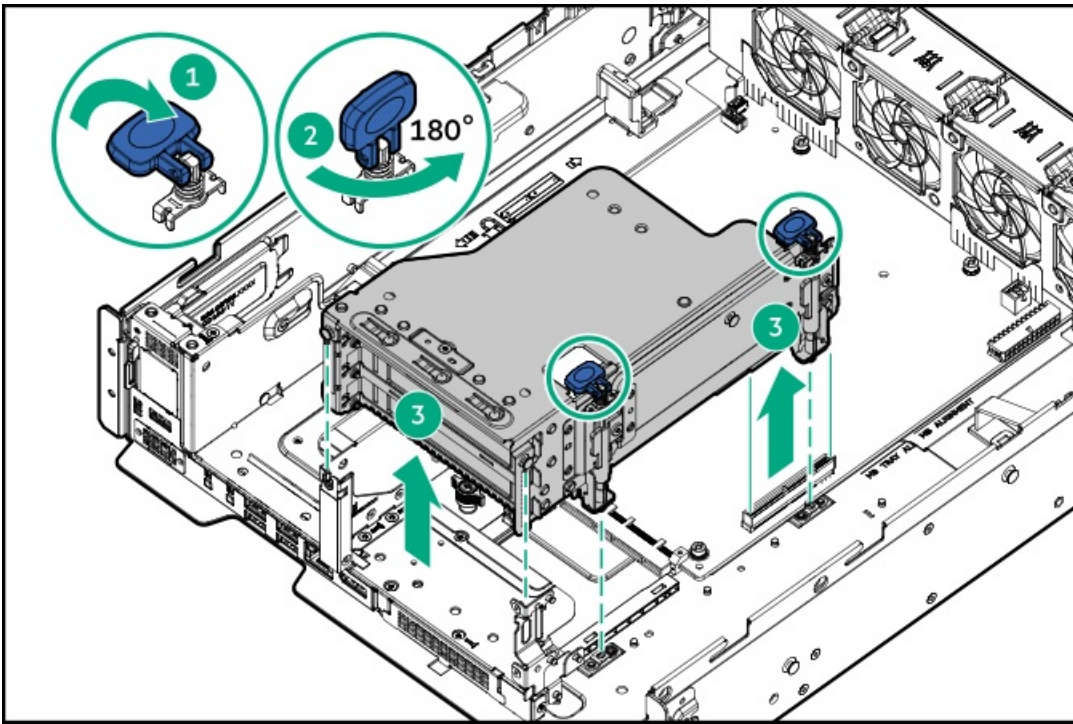

11. Remove the expansion card.

**Removing the base riser**

12. Loosen the riser screws to remove the base riser from the riser cage.

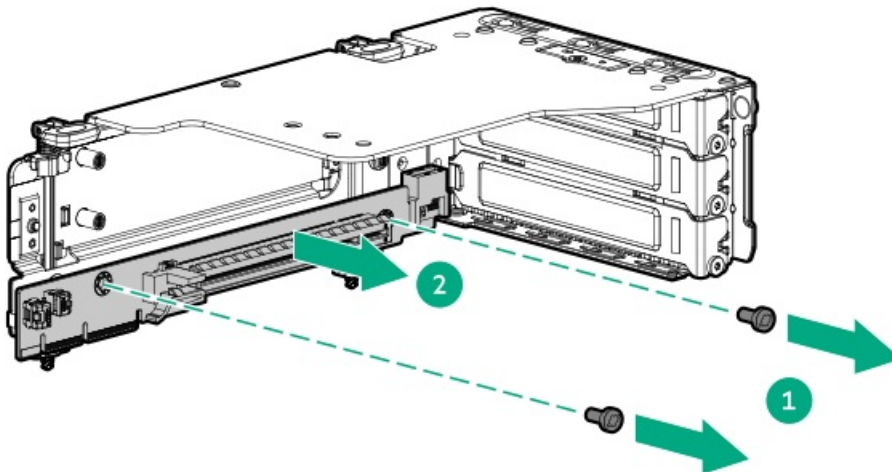

**Removing the stacking risers to remove the base riser**

13. If stacking risers are installed:

- a. Remove all risers from the riser cage.

For clarity, the cables of the stacking risers are not shown in the following image.

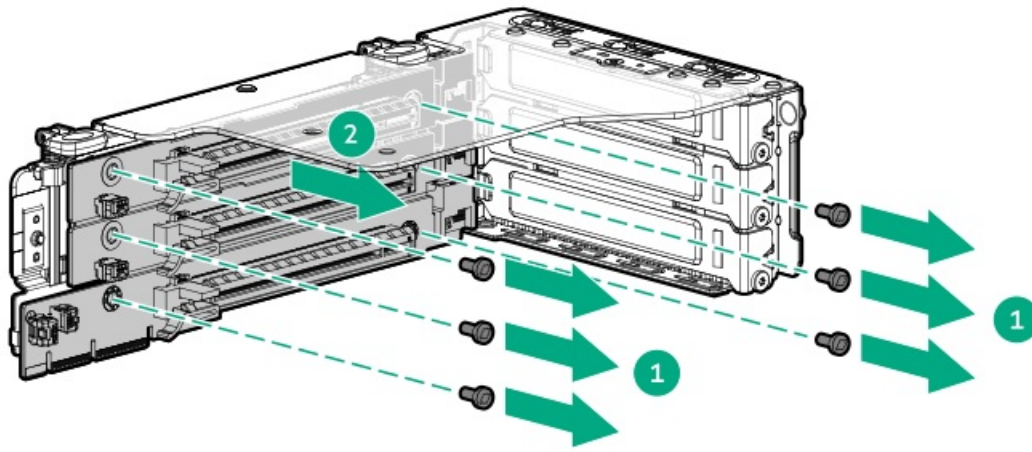

b. Detach the stacking risers from the base riser.

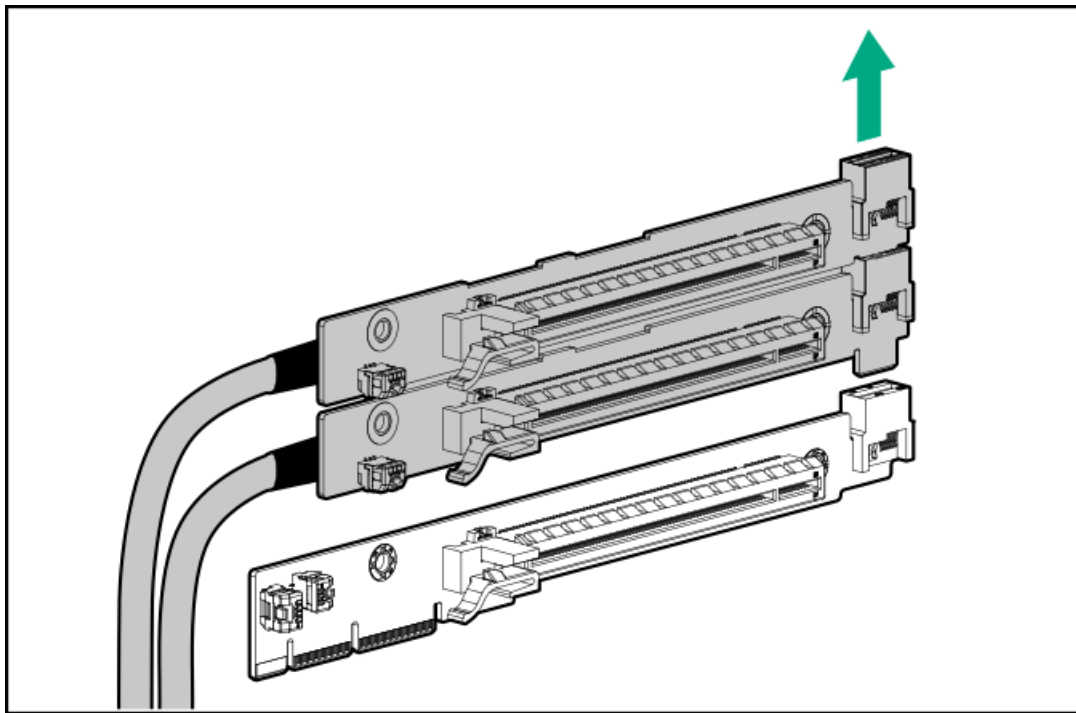

## Results

The removal procedure is complete. To replace the component, reverse this procedure.

## Removing and replacing a stacking riser in the three-slot riser cage

### Prerequisites

Before you perform this procedure, make sure that you have a T-15 Torx screwdriver available.

### About this task



#### CAUTION

To prevent improper cooling and thermal damage, do not operate the server unless all PCIe slots have either a riser slot blank or an expansion card installed.



### CAUTION

Before replacing a DIMM, backplane, expansion card, riser board, or other similar PCA components due to a perceived hardware error, make sure first that the component is firmly seated in the slot.

When installing the replacement component:

- Observe antistatic precautions.
- Handle the PCA only along the edges.
- Do not touch the components and connectors on the PCA.
- Do not bend or flex the PCA.

## Procedure

1. If installed, remove the front bezel.
2. Power down the server.
3. Remove all power:
  - a. Disconnect each power cord from the power source.
  - b. Disconnect each power cord from the server.
4. Disconnect all peripheral cables from the server.
5. Remove the server from a four-post rack.
6. Place the server on a flat, level work surface.
7. Remove the access panel.
8. Remove the air baffle.
9. Disconnect the stacking riser cables from the system board.
10. If an expansion card with internal cables is installed on the riser, disconnect the cables from the card.
11. Remove the three-slot riser cage:
  - a. Release the half-turn spring latches.
  - b. Use the blue touchpoints on both sides to lift the riser cage off the system board.

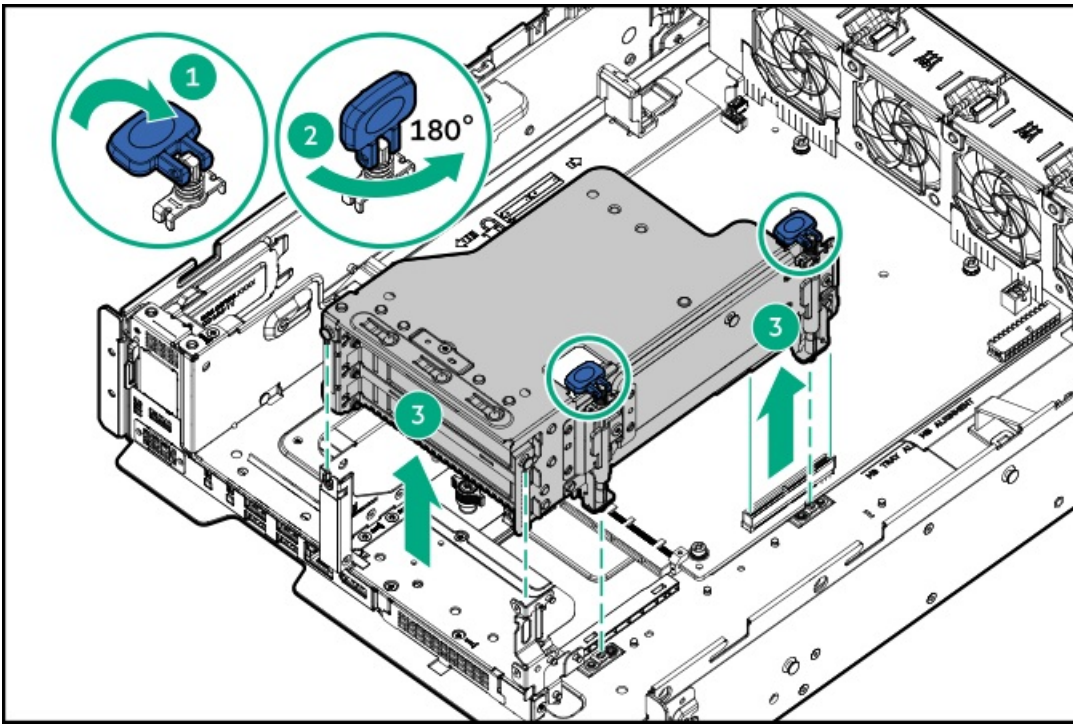

12. Remove the expansion card.

13. Remove the base riser and stacking risers from the riser cage.

For clarity, the cables of the stacking risers are not shown in the following image.

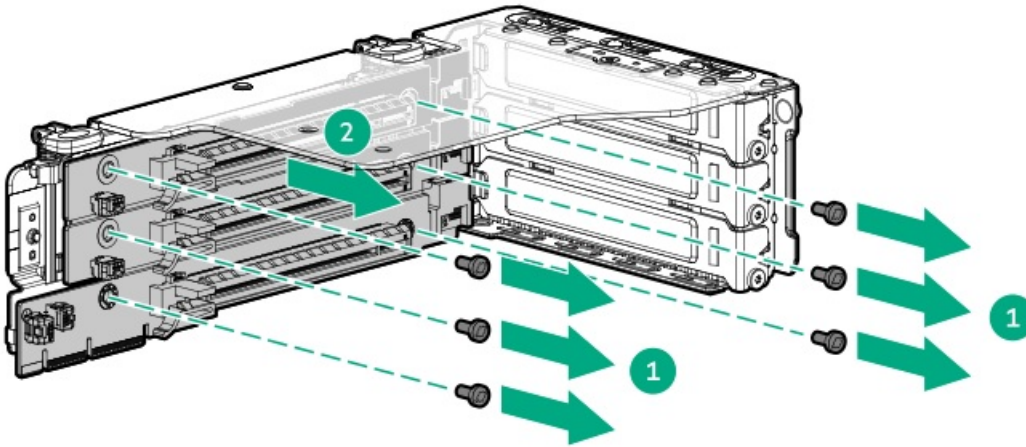

14. Detach the stacking risers from the base riser.

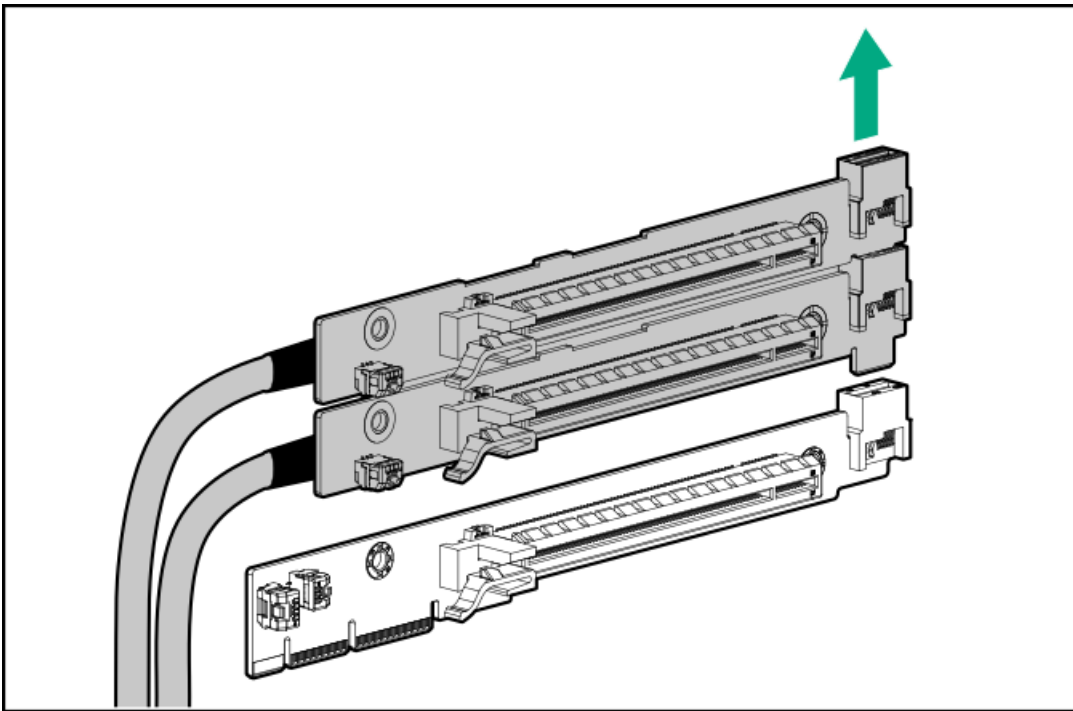

15. If needed, detach the slot 1 stacking riser from the slot 2 stacking riser.

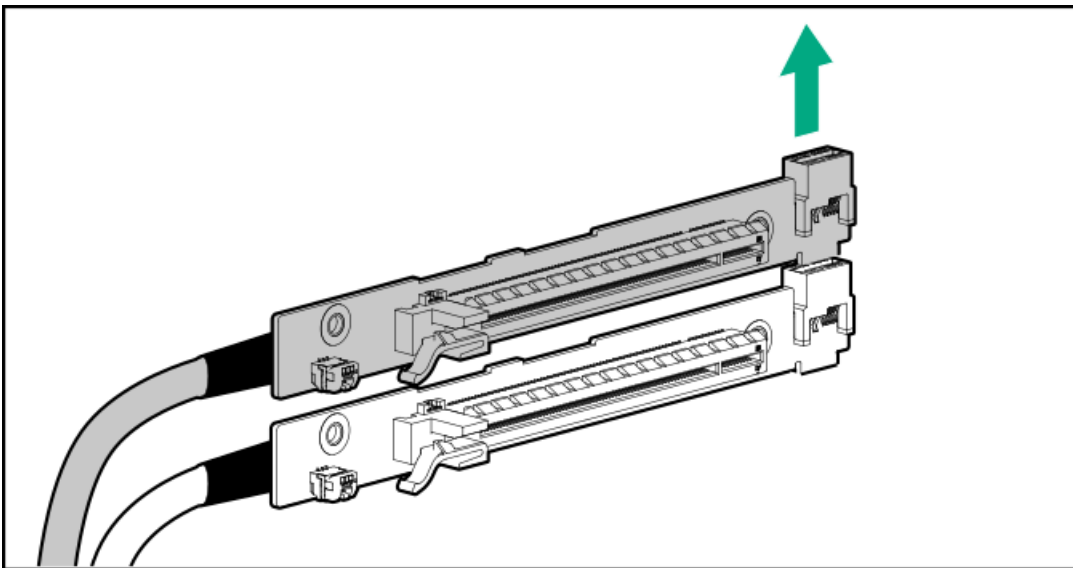

## Results

The removal procedure is complete. To replace the component, reverse this procedure.

## Removing and replacing the OCP 3.0 NIC

### About this task



#### CAUTION

To prevent improper cooling and thermal damage, do not operate the server unless all OCP slots have either an OCP option or a slot blank installed.

**CAUTION**

The port blank provides EMI shielding and helps maintain proper thermal status inside the server. Do not operate the server when a port blank is removed without the corresponding I/O port option installed.

**CAUTION**

Before replacing a DIMM, backplane, expansion card, riser board, or other similar PCA components due to a perceived hardware error, make sure first that the component is firmly seated in the slot.

When installing the replacement component:

- Observe antistatic precautions.
- Handle the PCA only along the edges.
- Do not touch the components and connectors on the PCA.
- Do not bend or flex the PCA.

## Procedure

1. If installed, remove the front bezel.
2. Power down the server.
3. Remove all power:
  - a. Disconnect each power cord from the power source.
  - b. Disconnect each power cord from the server.
4. Disconnect all peripheral cables from the server.
5. Remove the server from a four-post rack.
6. Place the server on a flat, level work surface.
7. Remove the access panel.
8. If stacking risers are installed in PCIe slots 1–2, do the following:
  - a. Remove the air baffle.
  - b. Disconnect the stacking riser cables from the system board.
9. If an expansion card with internal cables is installed on the riser, disconnect the cables from the card.
10. Remove the three-slot riser cage:
  - a. Release the half-turn spring latches.
  - b. Use the blue touchpoints on both sides to lift the riser cage off the system board.

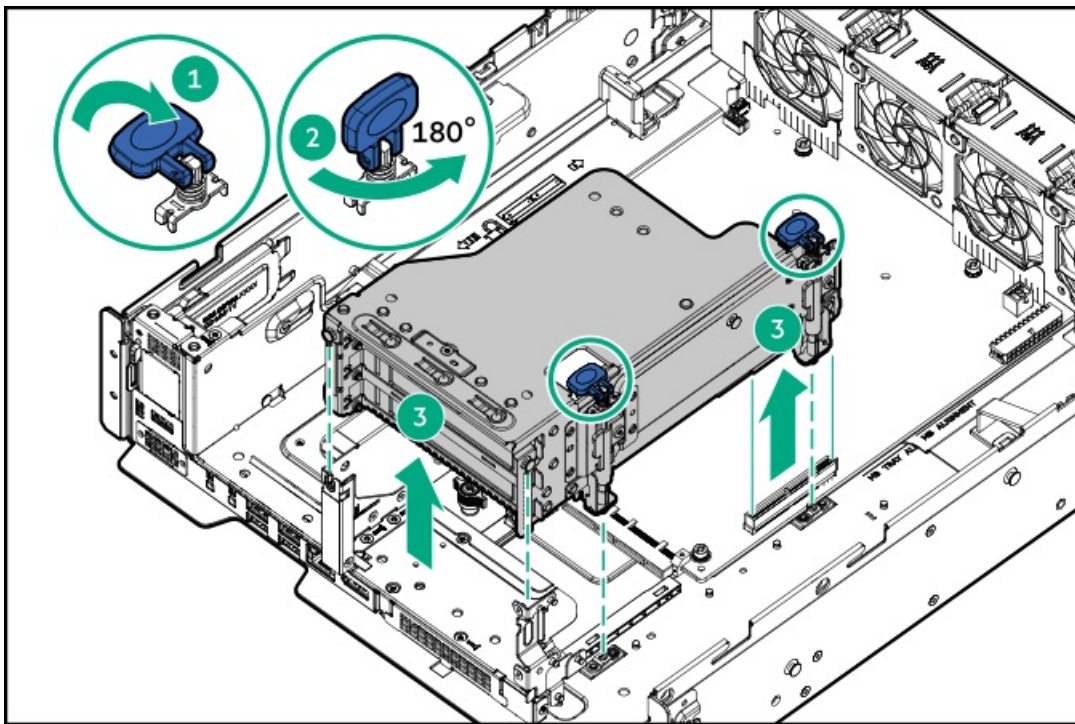

11. Remove the OCP 3.0 NIC:

- a. Rotate the locking pin to the open (vertical) position.
- b. Slide the adapter out of the bay.

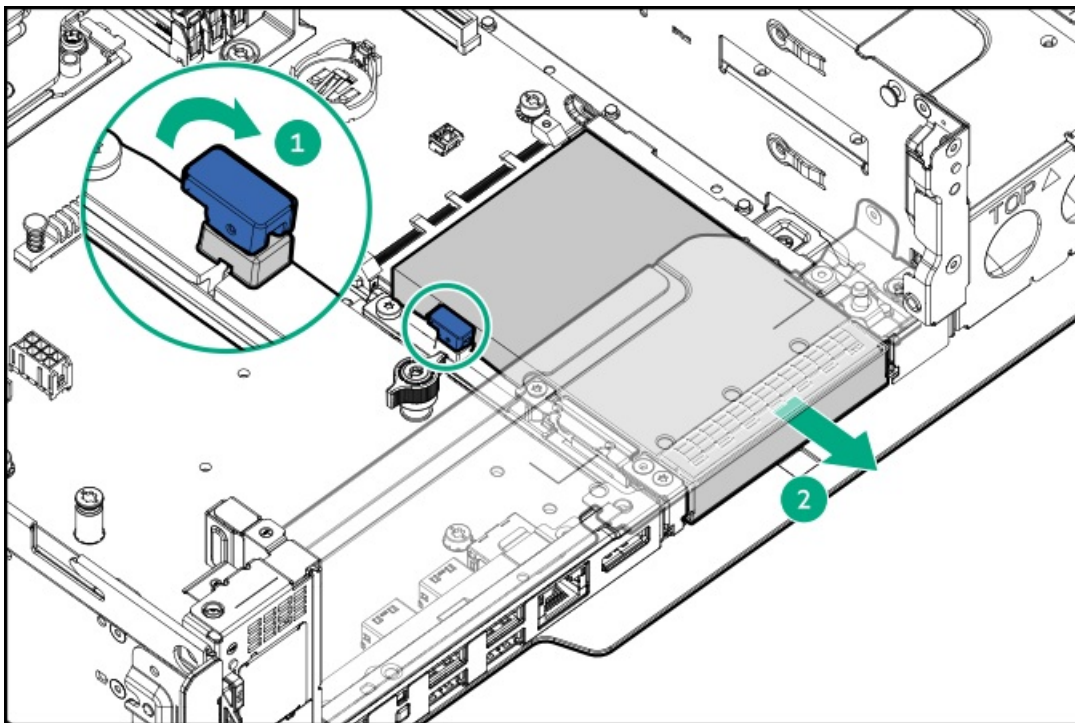

**Results**

The removal procedure is complete. To replace the component, reverse this procedure.

**HPE NS204i-u Boot Device replacement**

## Subtopics

[Removing and replacing a boot device drive in the boot device bracket](#)

[Removing and replacing the HPE NS204i-u Boot Device cage assembly in the boot device bracket](#)

[Removing and replacing the boot device bracket](#)

# Removing and replacing a boot device drive in the boot device bracket

## Prerequisites

- [Identify the HPE NS204i-u Boot Device components.](#)
- Identify the failed drive, do one of the following:
  - [Locate the boot device drive with a flashing amber or blue Online/Activity LED.](#)
  - iLO web interface: Storage page
  - UEFI System Utilities: System Utilities > Embedded Applications > Integrated Management Log > View IML
- Before you perform this procedure, make sure that you have the following items available:
  - T-10 Torx screwdriver
  - Phillips No. 1 screwdriver

## About this task

[https://sketchfab.com/models/bbb61184a86a4ca792b988e9caae5278/embed?ui\\_infos=0&ui\\_watermark=0&ui\\_help=0&ui\\_vr=0&ui\\_settings=0&ui\\_inspector=0&ui\\_hint=2&ui\\_animations=0&ui\\_color=01a982&ui\\_theme=dark&autostart=1&camera=0](https://sketchfab.com/models/bbb61184a86a4ca792b988e9caae5278/embed?ui_infos=0&ui_watermark=0&ui_help=0&ui_vr=0&ui_settings=0&ui_inspector=0&ui_hint=2&ui_animations=0&ui_color=01a982&ui_theme=dark&autostart=1&camera=0)



### CAUTION

A discharge of static electricity from a finger or other conductor might damage system boards or other static-sensitive devices. To prevent damage, observe [antistatic precautions](#).



### CAUTION

To prevent improper cooling and thermal damage, do not operate the server unless all bays are populated with either a component or a blank.



### IMPORTANT

For successful RAID 1 configuration, verify that the boot device SSDs have the same model number and firmware version:

- In the iLO web interface, see the Storage page.
- In UEFI System Utilities, see System Configuration > HPE NS204i Boot Controller > Physical Device Information.

Configurations with SSDs from different manufacturers are not supported.

## Procedure

1. [Back up all server data.](#)
2. If installed, [remove the front bezel.](#)
3. Remove the failed drive and replace it with a new drive:

- a. Press and hold the carrier latch.
- b. Pivot the latch to open.
- c. Slide the carrier out from the boot device cage.

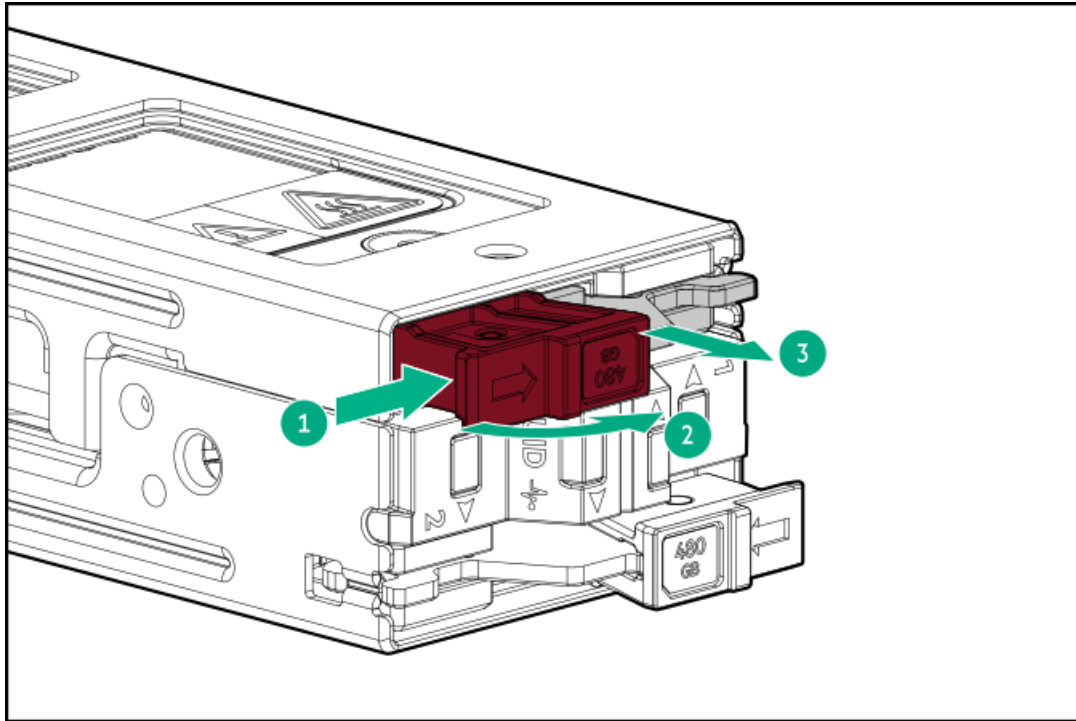

- d. Remove the SSD mounting screw.
- e. Tilt the SSD at a 45° angle, and then remove the failed SSD from the M.2 slot.

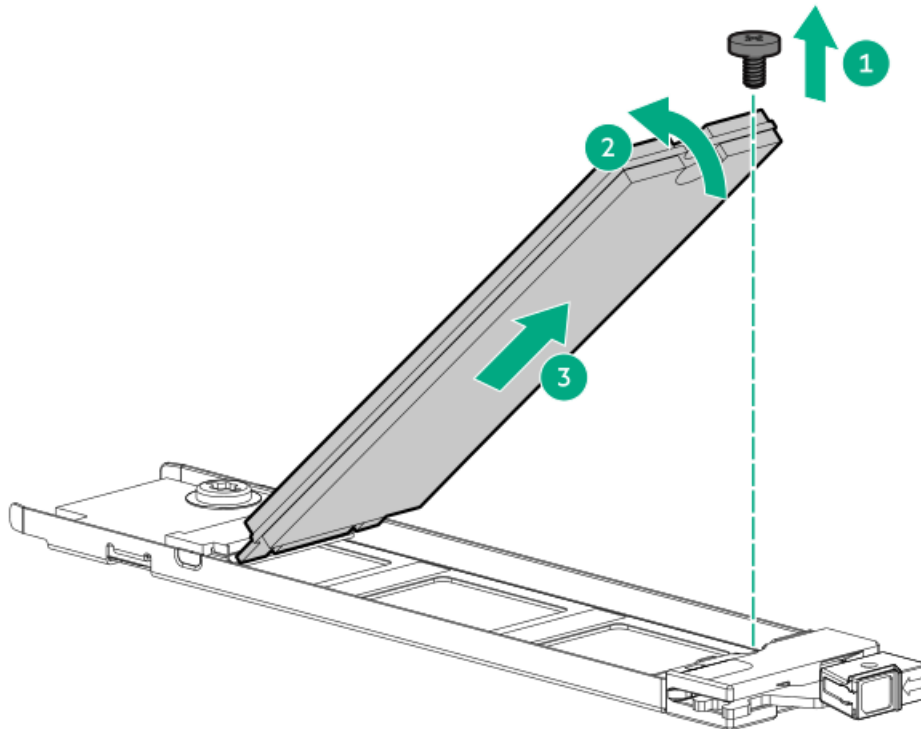

- f. Insert the new SSD into the M.2 slot at a 45° angle.
- g. Carefully press the SSD down to the horizontal position.
- h. Install the SSD mounting screw.

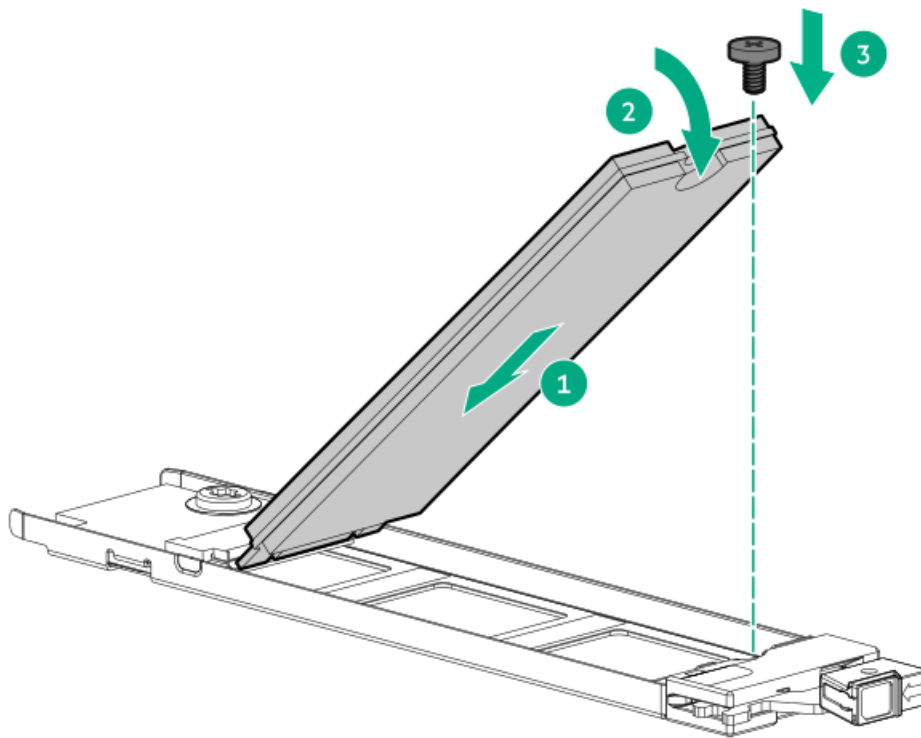

- i. If closed, pivot the carrier latch to open.
- j. Slide the carrier with the new SSD into the boot device cage.
- k. Pivot the latch to close.

Make sure that the carrier latch is locked on the boot device cage.

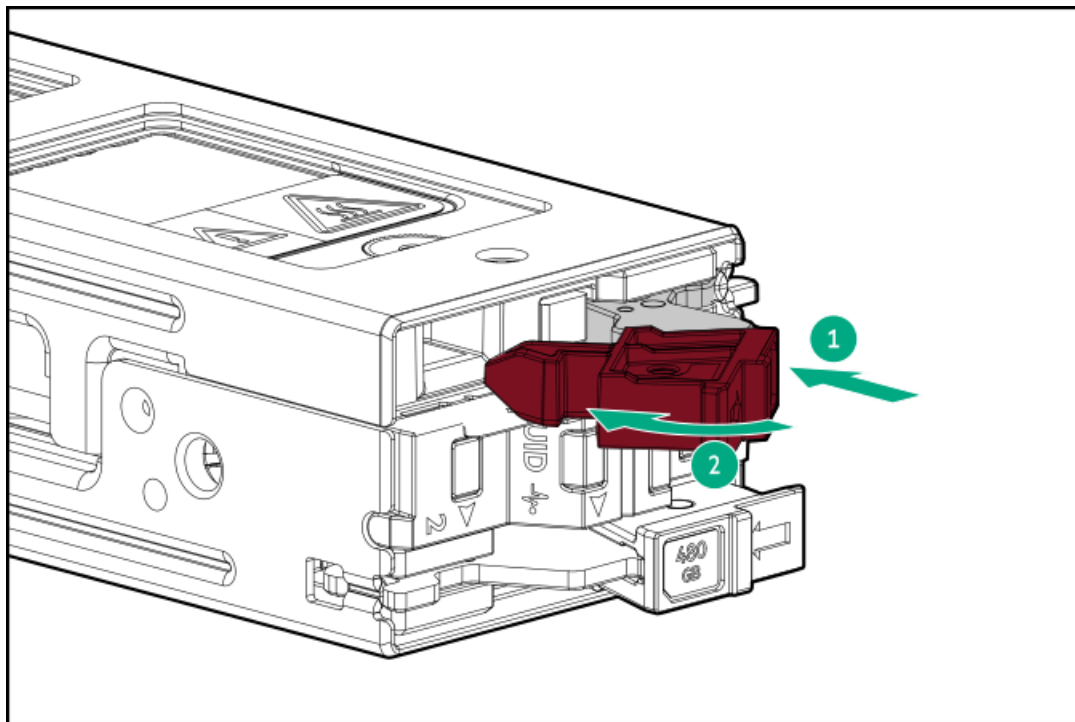

The boot device automatically rebuilds the RAID 1 volume.

- 4. If the newly installed SSD has a different model number as the SSD on the other drive carrier, replace the other SSD with one that is of the same model number as the new SSD.

Once both SSDs are installed, the boot device automatically rebuilds the RAID 1 volume.

- 5. To monitor the drive rebuild status, see any of the following:

- [Boot device Online/Activity LED](#)
- iLO web interface: Storage page
- UEFI System Utilities:
  - [System Utilities > System Configuration > Virtual Device Information > NS Volume > Virtual Device Detail Information](#)
  - [System Utilities > Embedded Applications > Integrated Management Log > View IML](#)

## Results

The replacement procedure is complete.

# Removing and replacing the HPE NS204i-u Boot Device cage assembly in the boot device bracket

## Prerequisites

- [Identify the HPE NS204i-u Boot Device components.](#)
- Before you perform this procedure, make sure that you have a T-10 Torx screwdriver available.

## About this task



### CAUTION

A discharge of static electricity from a finger or other conductor might damage system boards or other static-sensitive devices. To prevent damage, observe [antistatic precautions](#).



### CAUTION

To prevent improper cooling and thermal damage, do not operate the server unless all bays are populated with either a component or a blank.

## Procedure

1. [Back up all server data.](#)
2. If installed, [remove the front bezel.](#)
3. [Power down the server.](#)
4. Remove all power:
  - a. Disconnect each power cord from the power source.
  - b. Disconnect each power cord from the server.
5. Disconnect all peripheral cables from the server.
6. [Remove the server from a four-post rack.](#)
7. Place the server on a flat, level work surface.
8. [Remove the access panel.](#)
9. [Remove the air baffle.](#)
10. Disconnect the [boot device signal and power cables](#) from the system board.
11. Remove the boot device:

- a. Loosen the thumbscrew.
- b. Push the boot device bracket toward the rear panel to disengage it from the chassis.
- c. Lift the boot device bracket.

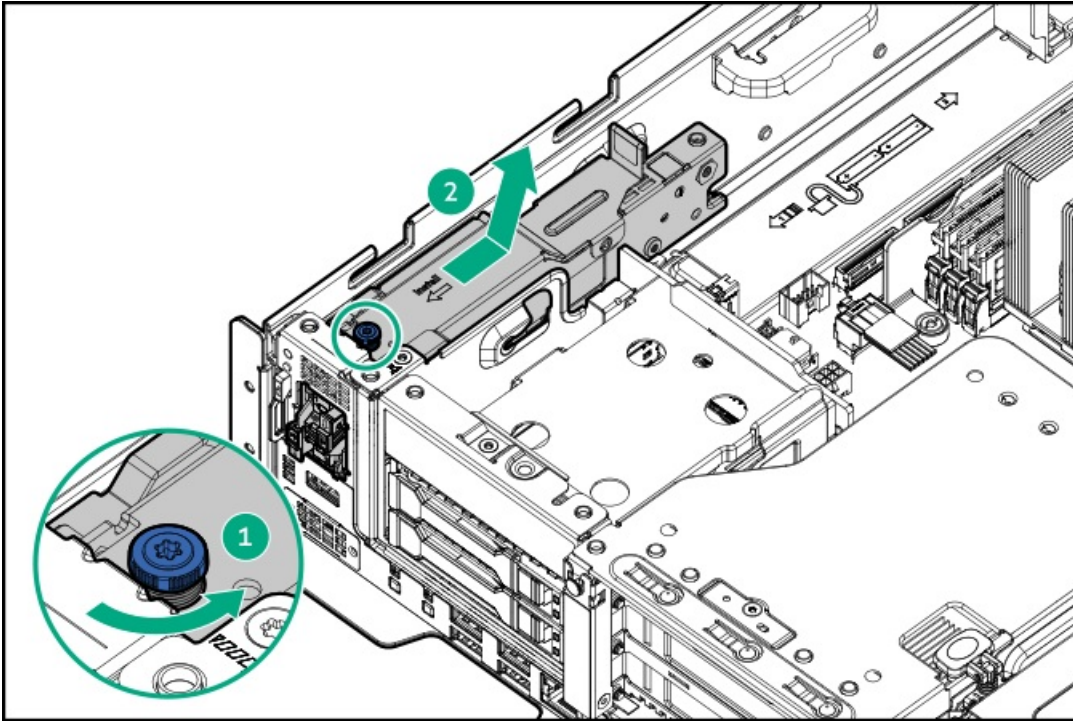

12. Remove the boot device from the bracket:

- a. Loosen the screws on the bracket.
- b. Remove the boot device.

Retain the screws for future use.

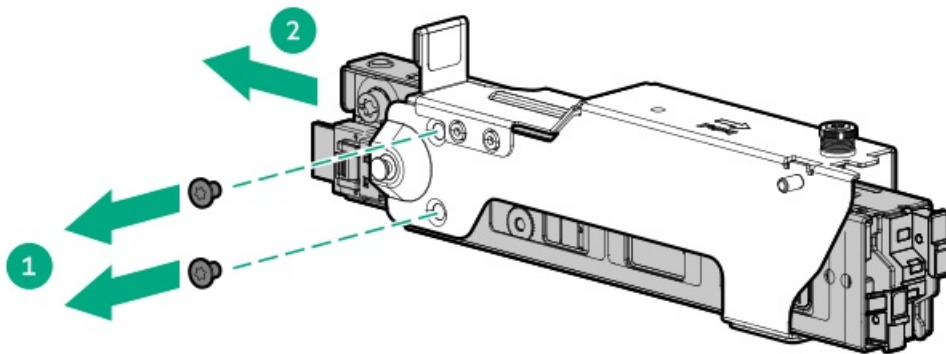

13. Remove the boot device carriers:

- a. Press and hold the carrier latch.
- b. Pivot the latch to open.
- c. Slide the carrier out from the boot device cage.

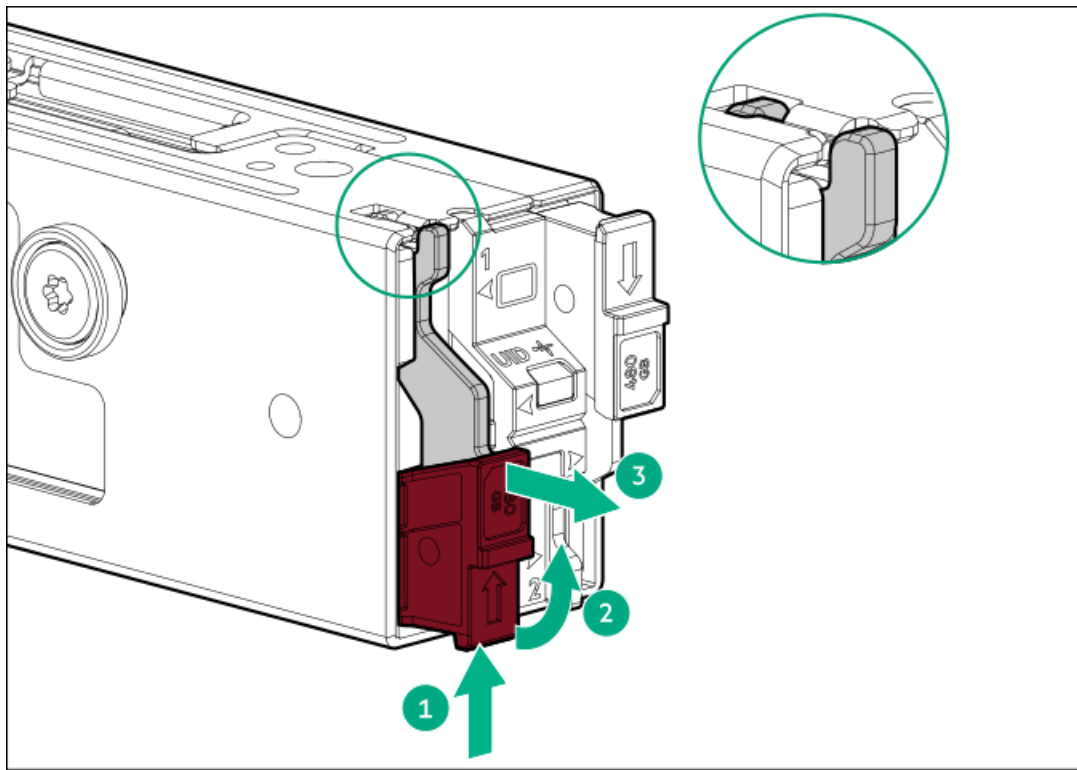

## Results

The removal procedure is complete. To replace the component, reverse this procedure.

## Removing and replacing the boot device bracket

### Prerequisites

Before you perform this procedure, make sure that you have a T-10 Torx screwdriver available.

### About this task



#### CAUTION

A discharge of static electricity from a finger or other conductor might damage system boards or other static-sensitive devices. To prevent damage, observe [antistatic precautions](#).



#### CAUTION

To prevent improper cooling and thermal damage, do not operate the server unless all bays are populated with either a component or a blank.

### Procedure

1. Back up all server data.
2. If installed, remove the front bezel.
3. Power down the server.
4. Remove all power:
  - a. Disconnect each power cord from the power source.
  - b. Disconnect each power cord from the server.

5. Disconnect all peripheral cables from the server.
6. Remove the server from a four-post rack.
7. Place the server on a flat, level work surface.
8. Remove the access panel.
9. Remove the air baffle.
10. Disconnect the boot device signal and power cables from the system board.
11. Remove the boot device:
  - a. Loosen the thumbscrew.
  - b. Push the boot device bracket toward the rear panel to disengage it from the chassis.
  - c. Lift the boot device bracket.

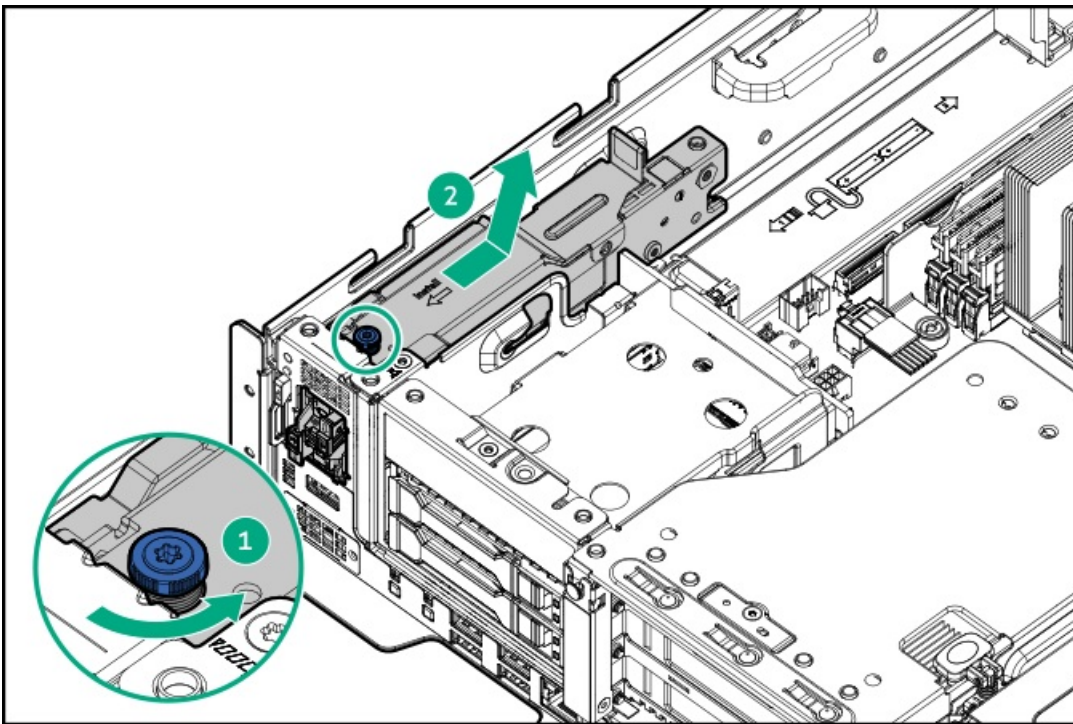

12. Remove the boot device from the bracket:
  - a. Loosen the screws on the bracket.
  - b. Remove the boot device.Retain the screws for future use.

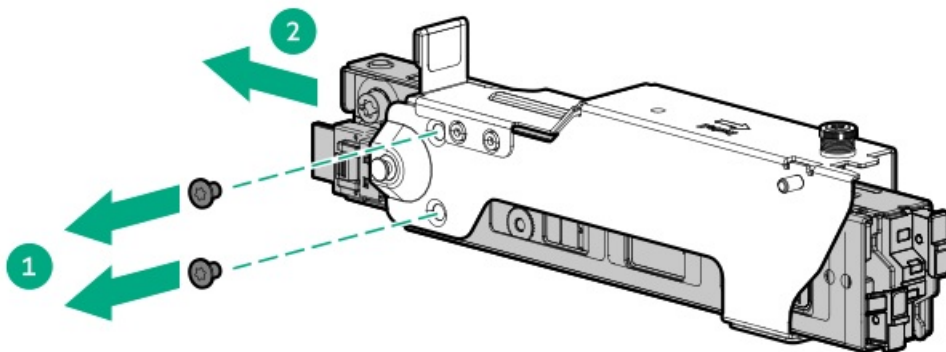

## Results

The removal procedure is complete. To replace the component, reverse this procedure.

## Removing and replacing the iLO service port cable

### Prerequisites

Before you perform this procedure, make sure that you have a T-10 Torx screwdriver available.

### About this task



#### CAUTION

A discharge of static electricity from a finger or other conductor might damage system boards or other static-sensitive devices. To prevent damage, observe [antistatic precautions](#).



#### CAUTION

To prevent improper cooling and thermal damage, do not operate the server unless all bays are populated with either a component or a blank.

### Procedure

1. If installed, [remove the front bezel](#).
2. [Power down the server](#).
3. Remove all power:
  - a. Disconnect each power cord from the power source.
  - b. Disconnect each power cord from the server.
4. Disconnect all peripheral cables from the server.
5. [Remove the server from a four-post rack](#).
6. Place the server on a flat, level work surface.
7. [Remove the access panel](#).
8. [Remove the air baffle](#).
9. [Remove the three-slot riser cage](#).
10. [Remove the drive base cage](#).
11. If installed, [remove the boot device bracket](#).
12. [Disconnect the iLO service port cable from the system board](#).
13. To remove the iLO service port cable, do the following:
  - a. Loosen the screw.
  - b. Remove the iLO service port cable from the front panel.
  - c. Release the cable from the metal tab.

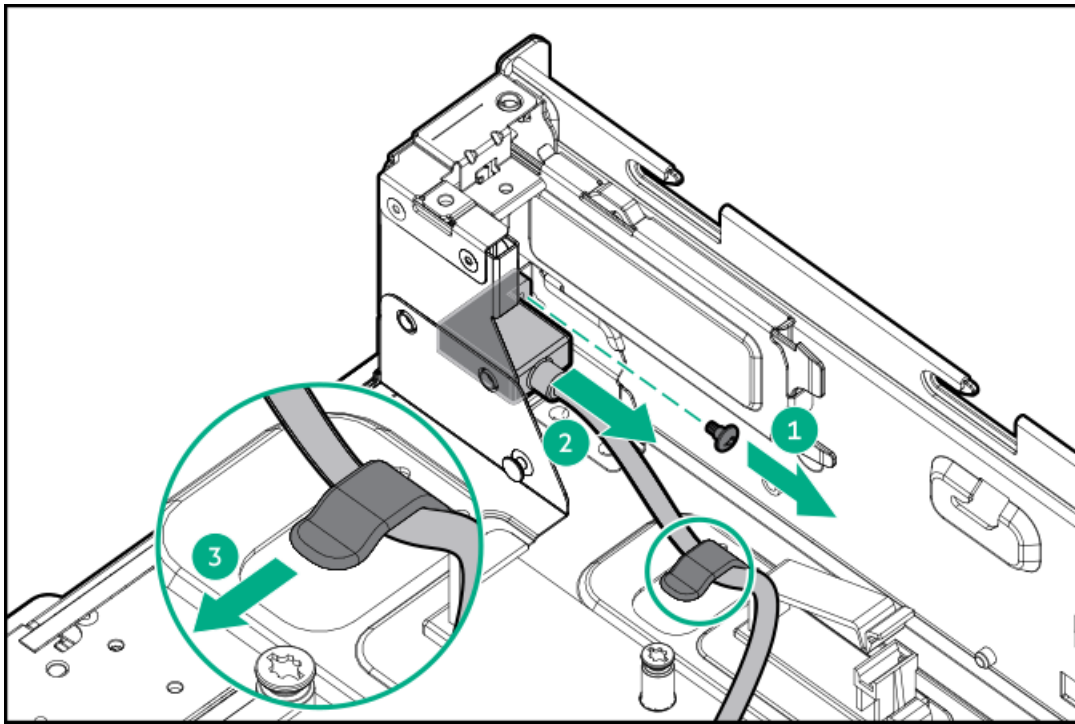

## Results

The removal procedure is complete. To replace the component, reverse this procedure.

## Removing and replacing the RJ45-serial port cable

### Prerequisites

Before you perform this procedure, make sure that you have a T-10 Torx screwdriver available.

### About this task



#### CAUTION

A discharge of static electricity from a finger or other conductor might damage system boards or other static-sensitive devices. To prevent damage, observe [antistatic precautions](#).



#### CAUTION

The port blank provides EMI shielding and helps maintain proper thermal status inside the server. Do not operate the server when a port blank is removed without the corresponding I/O port option installed.

### Procedure

1. If installed, [remove the front bezel](#).
2. [Power down the server](#).
3. Remove all power:
  - a. Disconnect each power cord from the power source.
  - b. Disconnect each power cord from the server.
4. Disconnect all peripheral cables from the server.

5. Remove the server from a four-post rack.
6. Place the server on a flat, level work surface.
7. Remove the access panel.
8. Remove the air baffle.
9. Remove the three-slot riser cage.
10. Remove the drive base cage.
11. If installed, remove the boot device bracket.
12. Disconnect the RJ45-serial port cable from the system board.
13. Remove the screws, and then remove the RJ45-serial port cable from the front panel.

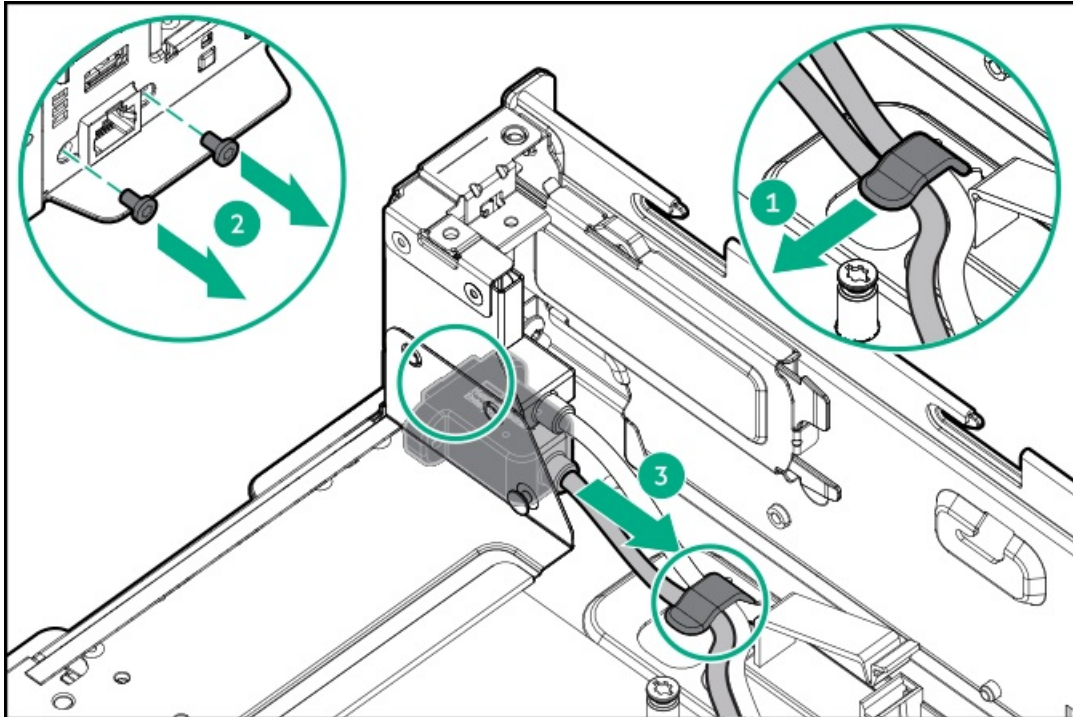

## Results

The removal procedure is complete. To replace the component, reverse this procedure.

## Removing and replacing the energy pack

### About this task

[https://sketchfab.com/models/2b1ad8674b5f4c8dad1b70200ee64ad0/embed?ui\\_infos=0&ui\\_watermark=0&ui\\_help=0&ui\\_vr=0&ui\\_settings=0&ui\\_inspector=0&ui\\_hint=2&ui\\_animations=0&ui\\_color=01a982&ui\\_theme=dark&autostart=1&camera=0](https://sketchfab.com/models/2b1ad8674b5f4c8dad1b70200ee64ad0/embed?ui_infos=0&ui_watermark=0&ui_help=0&ui_vr=0&ui_settings=0&ui_inspector=0&ui_hint=2&ui_animations=0&ui_color=01a982&ui_theme=dark&autostart=1&camera=0)



#### CAUTION

A discharge of static electricity from a finger or other conductor might damage system boards or other static-sensitive devices. To prevent damage, observe [antistatic precautions](#).

## Procedure

1. If installed, remove the front bezel.
2. Power down the server.
3. Remove all power:
  - a. Disconnect each power cord from the power source.
  - b. Disconnect each power cord from the server.
4. Disconnect all peripheral cables from the server.
5. Remove the server from a four-post rack.
6. Place the server on a flat, level work surface.
7. Remove the access panel.
8. Remove the air baffle.
9. To remove the energy pack, do the following:
  - a. Disconnect the energy pack cable.
  - b. Press and hold the retention latch.
  - c. Lift one end of the energy pack and release it from the latch.
  - d. Detach the energy pack from the chassis.

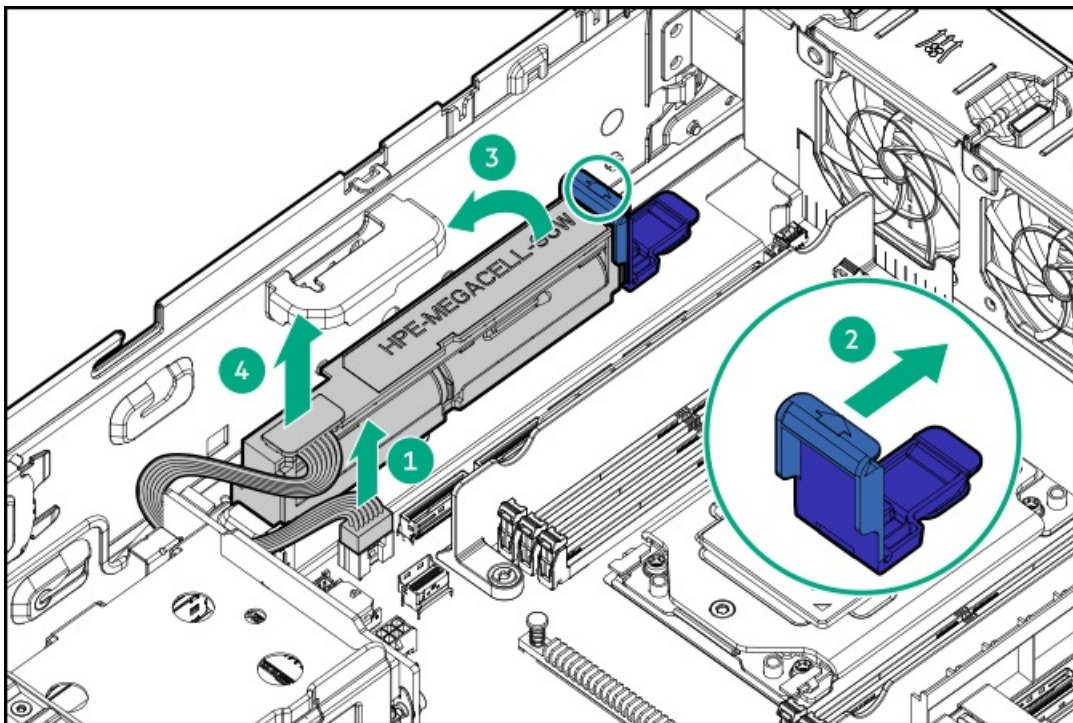

## Results

The removal procedure is complete. To replace the component, reverse this procedure.

## Removing and replacing the chassis intrusion detection switch

### About this task



## CAUTION

A discharge of static electricity from a finger or other conductor might damage system boards or other static-sensitive devices. To prevent damage, observe antistatic precautions.

## Procedure

1. If installed, remove the front bezel.
2. Power down the server.
3. Remove all power:
  - a. Disconnect each power cord from the power source.
  - b. Disconnect each power cord from the server.
4. Disconnect all peripheral cables from the server.
5. Remove the server from a four-post rack.
6. Place the server on a flat, level work surface.
7. Remove the access panel.
8. Remove the air baffle.
9. Remove the chassis intrusion detection switch:
  - a. Disconnect the switch cable from the system board.
  - b. While carefully retracting the snap-in latch, pull out the tab from the chassis slot.

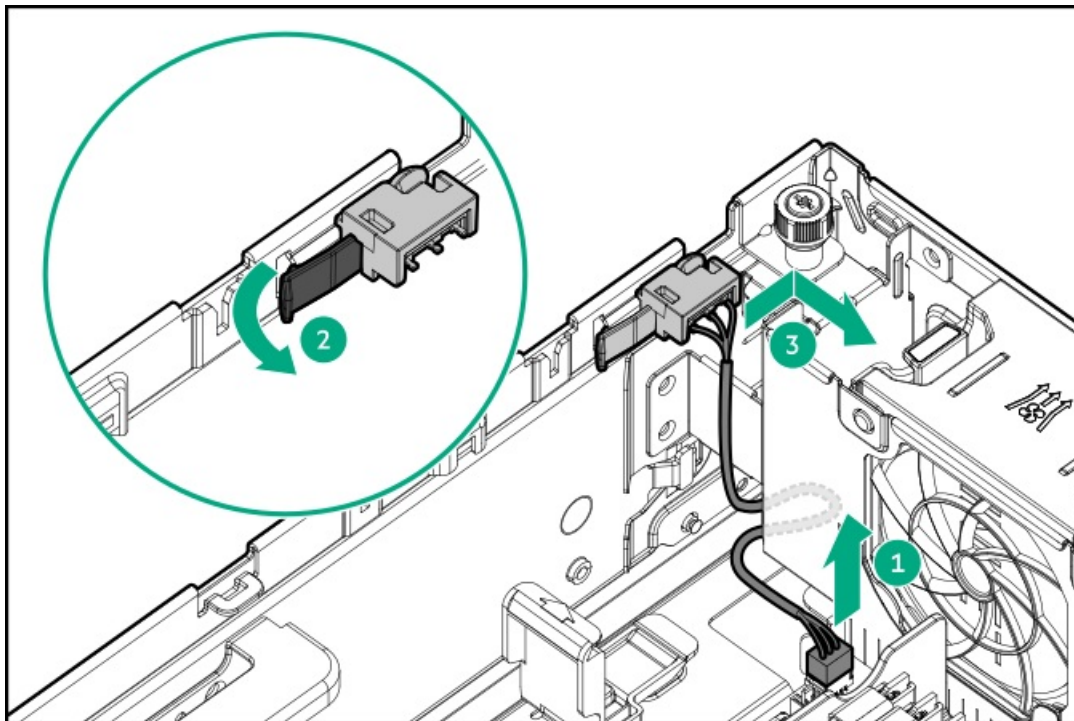

## Results

The removal procedure is complete. To replace the component, reverse this procedure.

## Heatsink replacement

## Subtopics

### [Heatsink label](#)

### [Removing the heatsink](#)

### [Installing the heatsink](#)

## Heatsink label

Before installing or removing the heatsink, review the screw numbering on the heatsink label:

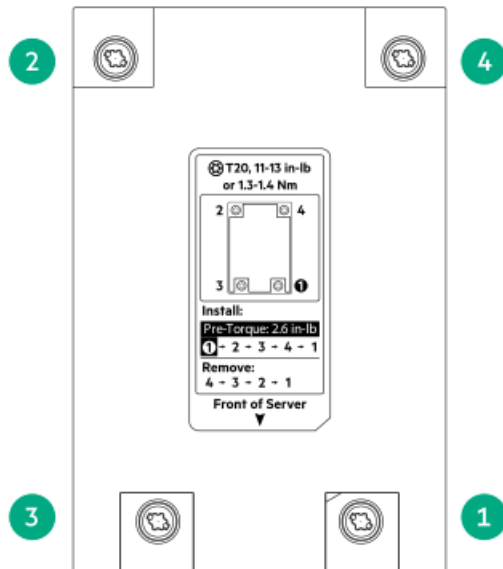

- Identify the correct sequence for:
  - Loosening the heatsink screws:  
4-3-2-1
  - Tightening the heatsink screws:  
1-2-3-4-1
- Verify that the **Front of Server** arrow points to the front panel.

## Removing the heatsink

### Prerequisites

- [Identify the heatsink and processor socket components.](#)
- Before you perform this procedure, make sure that you have the following items available:
  - T-20 Torx screwdriver
  - Alcohol wipe

### About this task

**WARNING**

To reduce the risk of personal injury from hot surfaces, allow the drives and the internal system components to cool before touching them.

**CAUTION**

A discharge of static electricity from a finger or other conductor might damage system boards or other static-sensitive devices. To prevent damage, observe antistatic precautions.

**Procedure**

1. If installed, remove the front bezel.
  2. Power down the server.
  3. Remove all power:
    - a. Disconnect each power cord from the power source.
    - b. Disconnect each power cord from the server.
  4. Disconnect all peripheral cables from the server.
  5. Remove the server from the rack.
  6. Place the server on a flat, level work surface.
  7. Remove the access panel.
  8. Remove the air baffle.
  9. Allow all internal system components to cool before continuing.
  10.  **CAUTION**  
To prevent mechanical damage or depositing oil on your hands or other contaminants to the heatsink contact surface, hold the heatsink only by the edge of its base plate. Do not touch the heatsink fins.
- Remove the heatsink:
- a. Review the heatsink screw numbering on the heatsink label.
  - b. Use a T-20 Torx screwdriver to loosen one pair of diagonally opposite heatsink screws (callouts 4 and 3), and then loosen the other pair of heatsink screws (callouts 2 and 1).

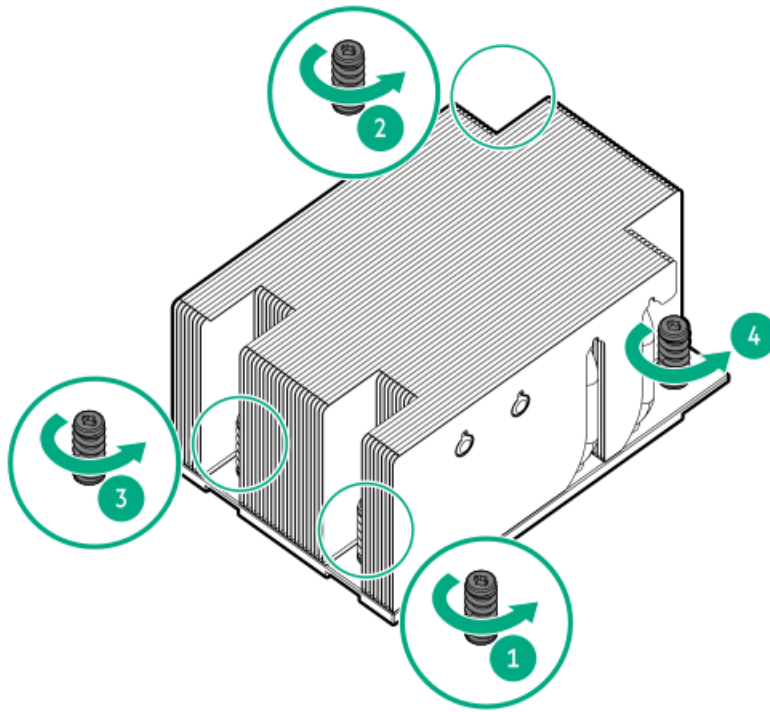

11. Lift the heatsink away from the processor socket.

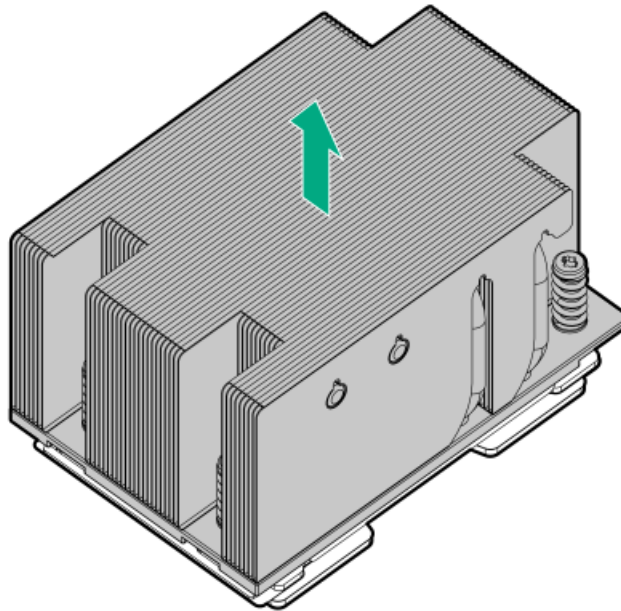

12. Place the heatsink on a flat work surface with its contact side facing up.

13. Use an alcohol wipe to remove the existing thermal grease from the processor.

Allow the alcohol to evaporate before continuing.

## Installing the heatsink

### Prerequisites

Before you perform this procedure, make sure that you have a torque screwdriver with T-20 Torx bit available.

## About this task



### CAUTION

A discharge of static electricity from a finger or other conductor might damage system boards or other static-sensitive devices. To prevent damage, observe [antistatic precautions](#).

## Procedure

1. Remove the thermal interface protective cover from the new heatsink.

2.



### CAUTION

To prevent mechanical damage or depositing oil on your hands or other contaminants to the heatsink contact surface, hold the heatsink only by the edge of its base plate. Do not touch the heatsink fins.



### CAUTION

To prevent thermal failure or component damage, do not move the heatsink once the bottom of its base plate touches the top of the processor. Excessive heatsink movement can cause the thermal grease to smear and become uneven. Voids in the compound can adversely impact the transfer of heat away from the processor.

Install the heatsink:

- a. Review the heatsink screw numbering on the [heatsink label](#).
- b. Note the **Front of server** text on the heatsink label to correctly orient the heatsink over the processor socket.
- c. Position the heatsink on top of the processor, ensuring that it is properly seated before securing the screws.

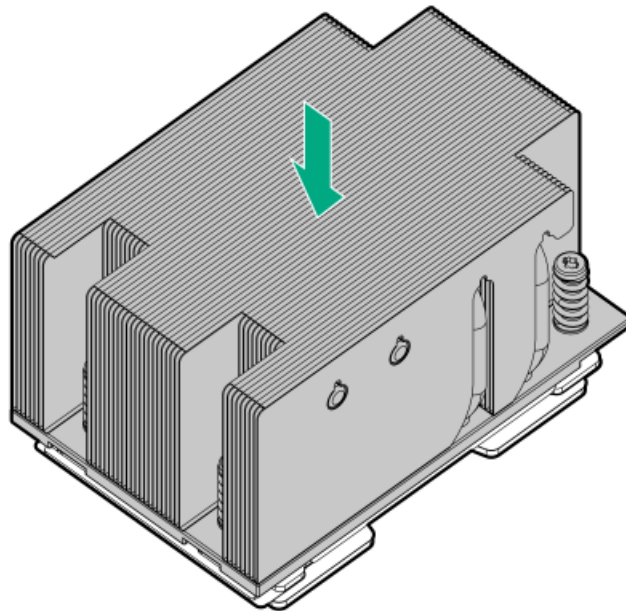

- d. Apply a pre-torque of 0.29 N-m (2.60 lbf-in) to the heatsink screw number 1 (callout 1) using a torque screwdriver.

Tighten the heatsink screws in the sequence specified on the [heatsink label](#).

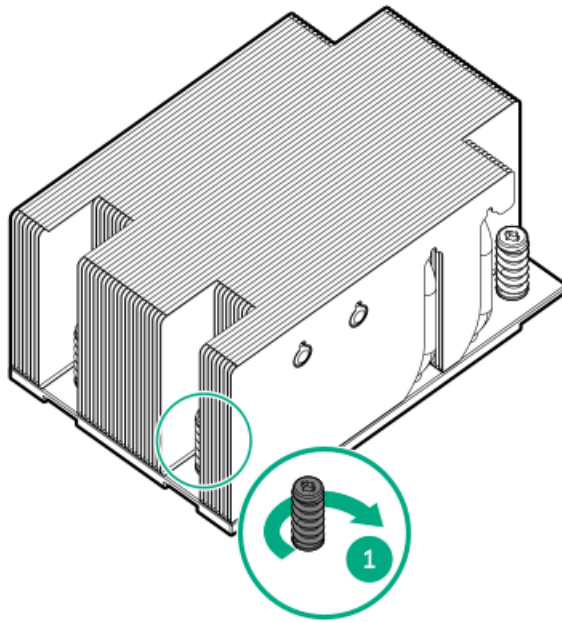

e. When using a torque screwdriver to tighten the heatsink screws, set a torque between 1.24 N-m (11 lbf-in) to 1.47 N-m (13 lbf-in).

f. Use a torque screwdriver to tighten the heatsink screw numbers 2, 3, 4 and 1 (callouts 2, 3, 4, and 1).

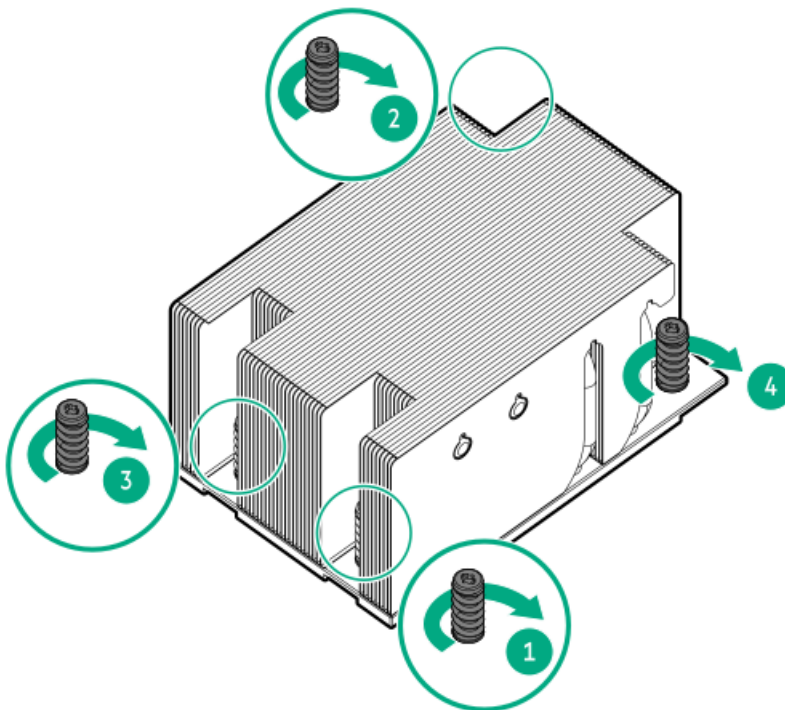

3. Install the air baffle.
4. Install the access panel.
5. Install the server into the rack.
6. Connect all peripheral cables to the server.
7. Connect each power cord to the server.
8. Connect each power cord to the power source.

9. [Power up the server.](#)
10. If removed, install the front bezel.

## Results

The replacement procedure is complete.

## Processor replacement

### Subtopics

[Processor cautions](#)

[Removing the processor](#)

[Installing the processor](#)

[Reconfiguring the system date and time settings](#)

## Processor cautions



### CAUTION

To avoid damage to the processor or system board, only authorized personnel should attempt to replace or install the processor in this server.



### CAUTION

To prevent possible server malfunction and damage to the equipment, multiprocessor configurations must contain processors with the same part number.



### CAUTION

**The pins on the processor socket and on the processor are very fragile and easily damaged . To avoid component damage, do not touch these pins.** Any damage to them might require replacing the system board and/or processor.



### IMPORTANT

If installing a processor with a faster speed, update the system ROM before installing the processor. To download firmware, see [Updating firmware or system ROM](#).



### IMPORTANT

After removing a processor from the system board, the server resets the date and time. For information on reconfiguring these settings, see [Reconfiguring the system date and time settings](#).

## Removing the processor

### Prerequisites

- [Identify the processor and socket components.](#)
- [Review the processor cautions.](#)

- Before you perform this procedure, make sure that you have the following items available:
  - T-20 Torx screwdriver
  - Alcohol wipe

## About this task



### WARNING

To reduce the risk of personal injury from hot surfaces, allow the drives and the internal system components to cool before touching them.



### CAUTION

A discharge of static electricity from a finger or other conductor might damage system boards or other static-sensitive devices. To prevent damage, observe [antistatic precautions](#).

## Procedure

1. If installed, [remove the front bezel](#).
2. [Power down the server](#).
3. Remove all power:
  - a. Disconnect each power cord from the power source.
  - b. Disconnect each power cord from the server.
4. Disconnect all peripheral cables from the server.
5. [Remove the server from the rack](#).
6. Place the server on a flat, level work surface.
7. [Remove the access panel](#).
8. [Remove the air baffle](#).
9. Allow all internal system components to cool before continuing.

10.  **CAUTION**  
To prevent mechanical damage or depositing oil on your hands or other contaminants to the heatsink contact surface, hold the heatsink only by the edge of its base plate. Do not touch the heatsink fins.

Remove the heatsink:

- a. Review the heatsink screw numbering on the [heatsink label](#).
- b. Use a T-20 Torx screwdriver to loosen one pair of diagonally opposite heatsink screws (callouts 4 and 3), and then loosen the other pair of heatsink screws (callouts 2 and 1).

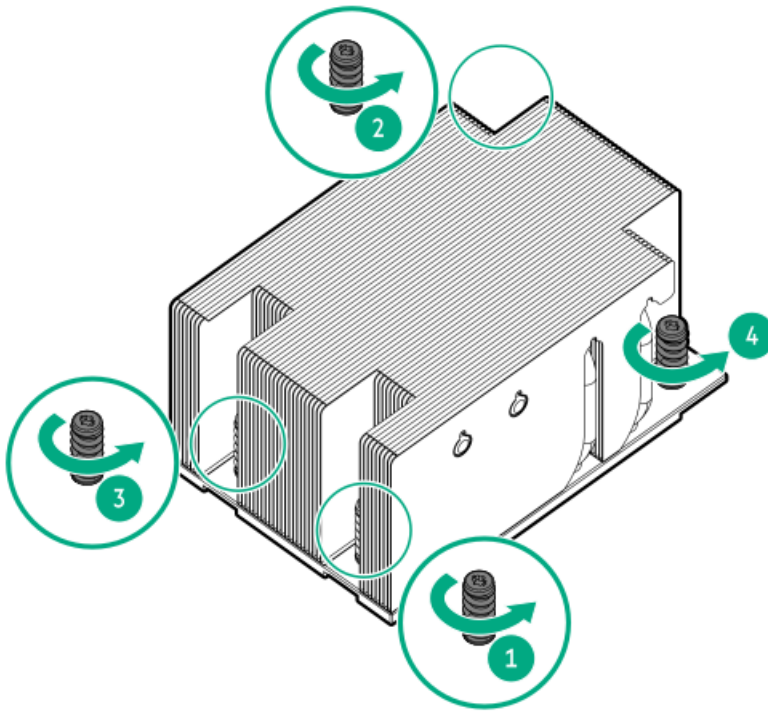

11. Lift the heatsink away from the processor socket.

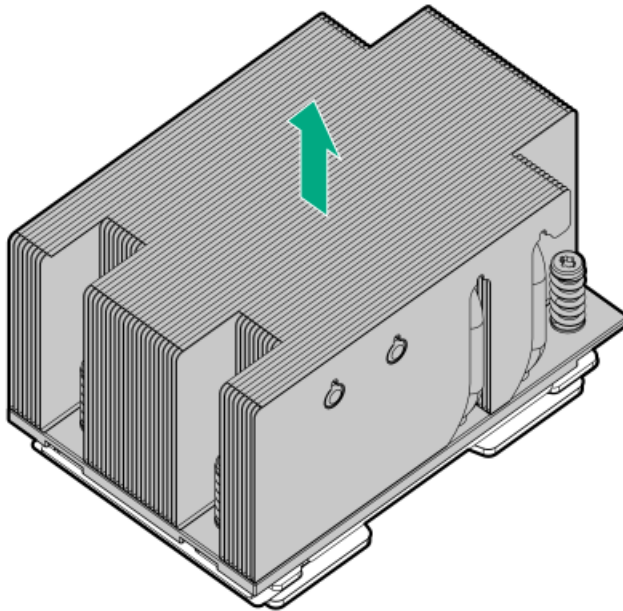

12. Place the heatsink on a flat work surface with its contact side facing up.

13. Use an alcohol wipe to remove the existing thermal grease from the heatsink and processor.

Allow the alcohol to evaporate before continuing.

14. Remove the processor:

- a. While holding the sides of the retention frame, loosen the frame screws (callouts 1, 2, and 3) in the sequence specified on the frame.

This retention frame is spring-loaded. After the screws are loosened enough, hold the retention frame as it automatically pivots to a vertical position (callout 4).



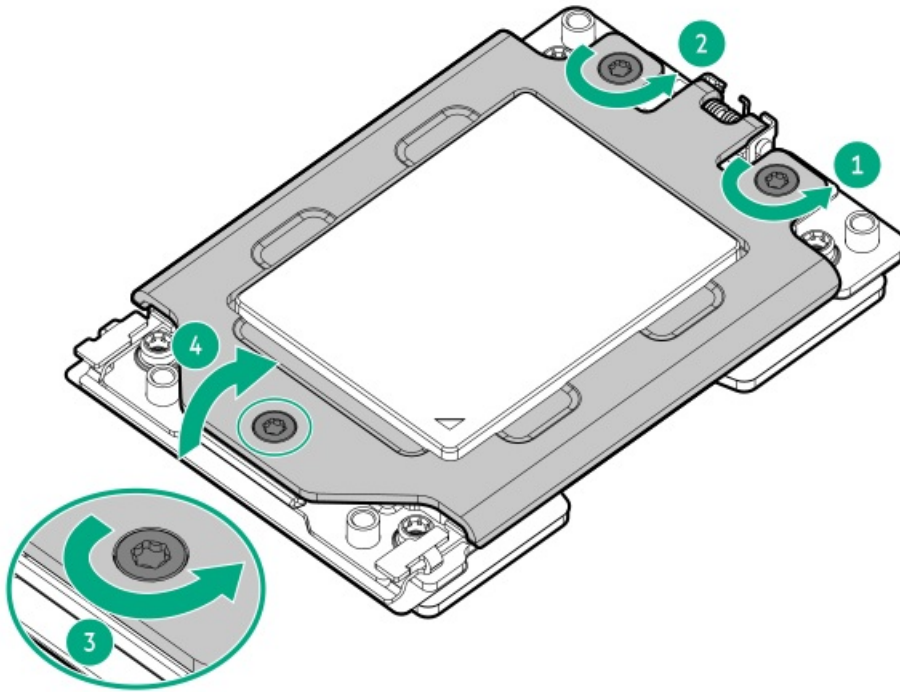

- b. Hold the lift tabs and pivot the rail frame to the vertical position (callout 1).
- c. Slide the processor out of the rail frame (callout 2).



**CAUTION**

The pins on the processor socket and on the processor are very fragile and easily damaged . To avoid component damage, do not touch these pins. Any damage to them might require replacing the system board and/or processor.

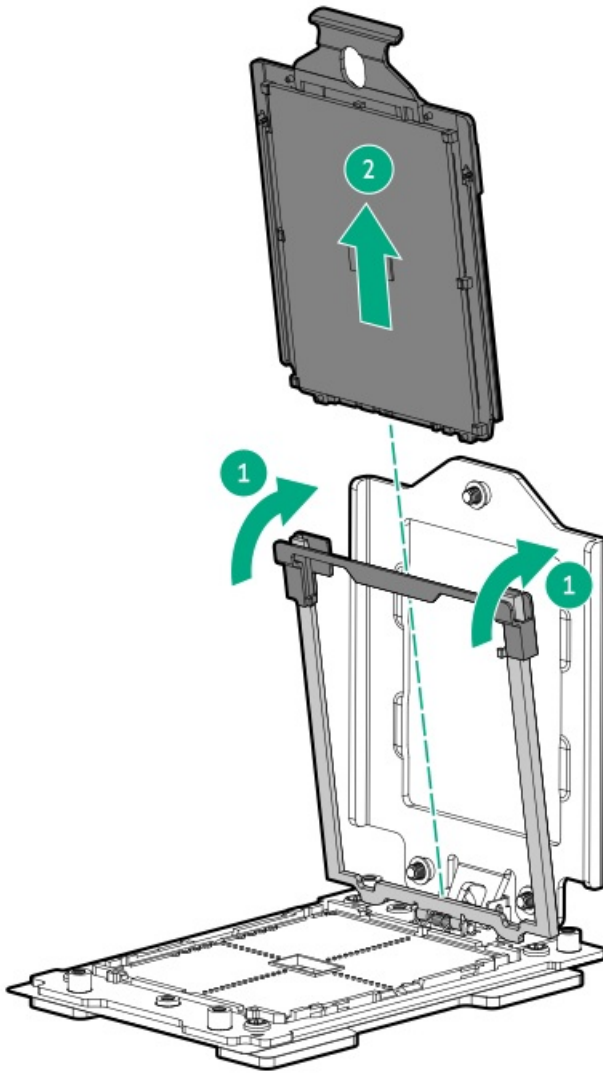

15. Do not touch the pin field on the socket and the processor contacts.

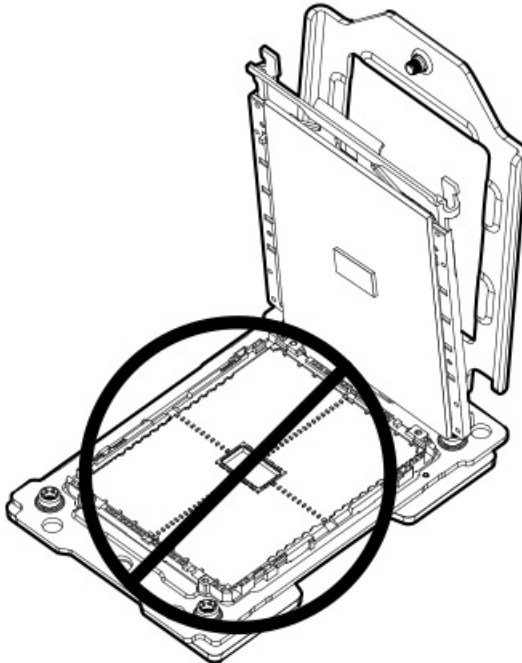

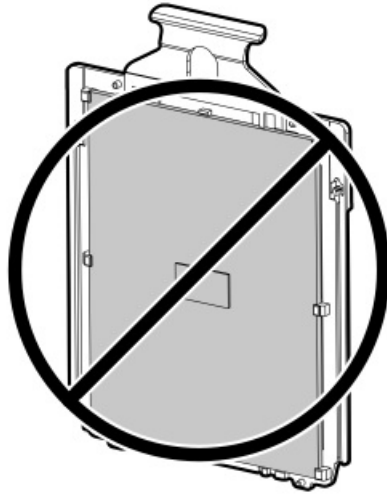

## Installing the processor

### Prerequisites

- [Identify the processor and socket components.](#)
- [Review the processor cautions.](#)
- Before you perform this procedure, make sure that you have the following items available:
  - Torque screwdriver with T-20 Torx bit
  - Thermal grease (spare part number: 777298-001)

### About this task



#### CAUTION

A discharge of static electricity from a finger or other conductor might damage system boards or other static-sensitive devices. To prevent damage, observe [antistatic precautions](#).

### Procedure

1. Install the processor:
  - a. Hold the processor by its carrier handle.
  - b. Slide the processor into the rail frame until it engages with a click sound.

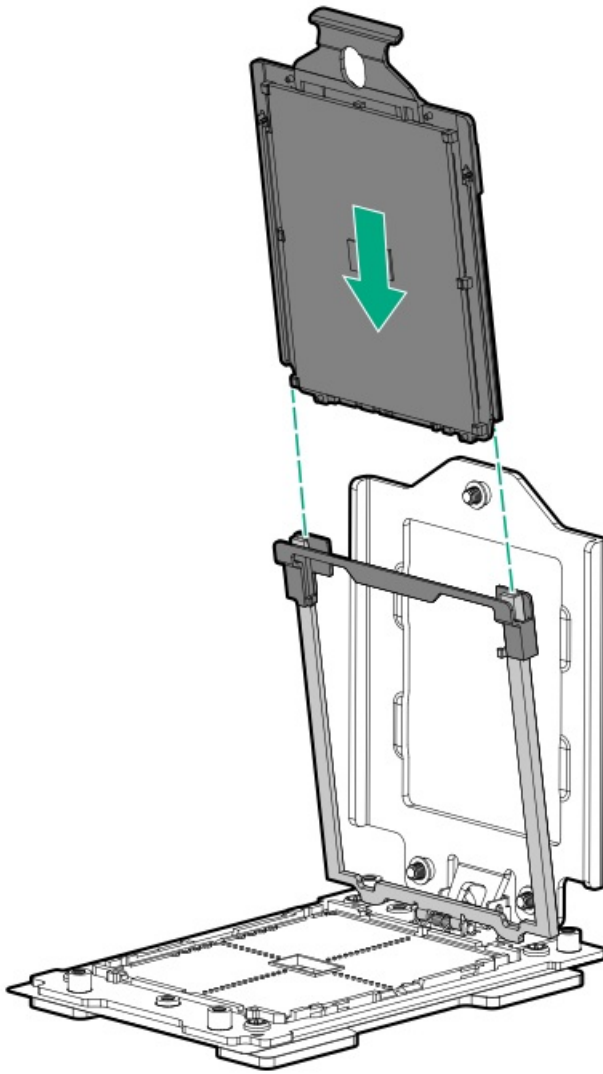

2. Hold the lift tabs and pivot the rail frame to the closed position.

A click sound indicates that the rail frame is properly engaged.

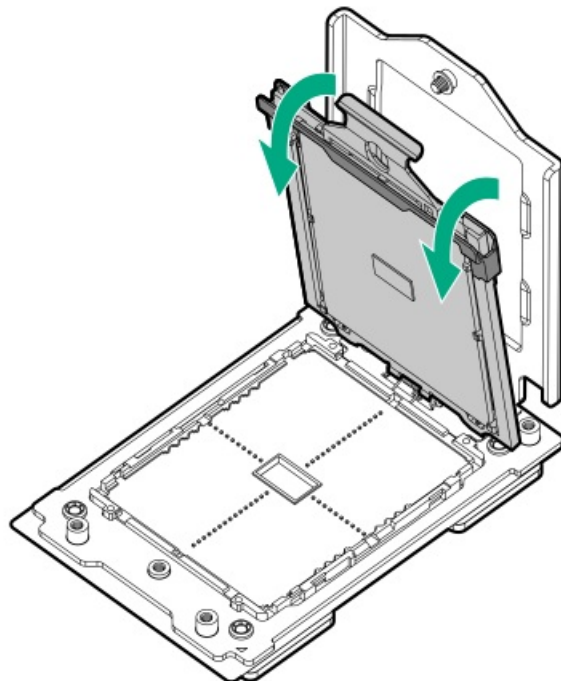

3. Close the retention frame:

- a. When using a torque screwdriver to tighten the retention frame screws, set a torque between 1.23 N-m (10.89 lbf-in) to 1.48 N-m (13.10 lbf-in).
- b. Pivot the spring-loaded retention frame downward and hold it down (callout 1).
- c. Tighten the retention frame screws (callouts 2, 3, and 4) in the sequence specified on the frame.

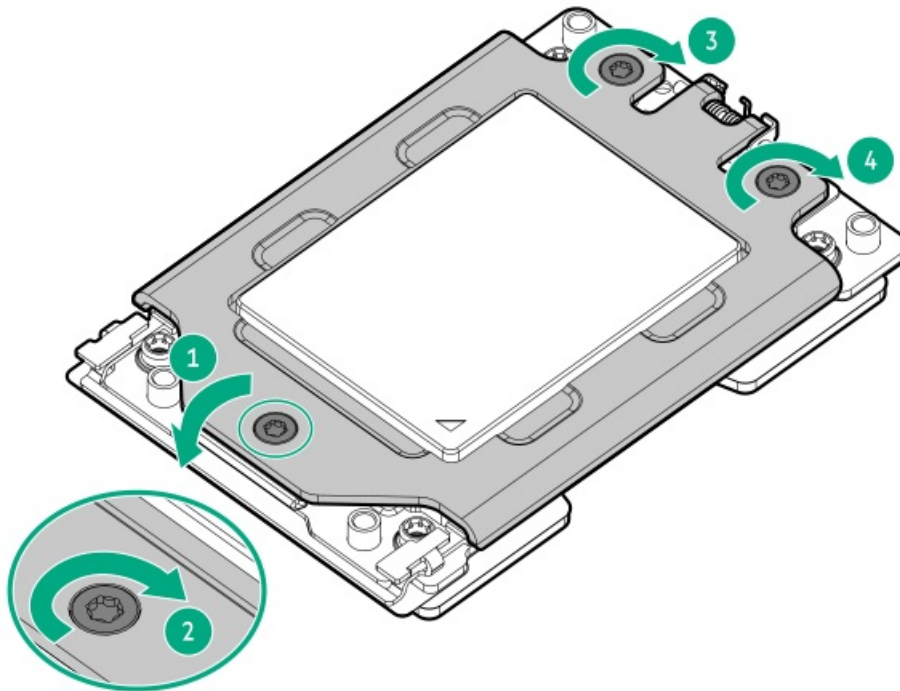

4. If you are using the same heatsink, apply the full content of the thermal grease syringes on top of the processor. Follow the pattern shown in the following image.

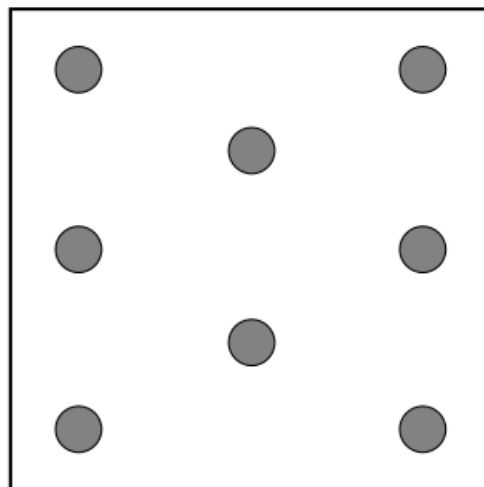

5.  **CAUTION**

To prevent mechanical damage or depositing oil on your hands or other contaminants to the heatsink contact surface, hold the heatsink only by the edge of its base plate. Do not touch the heatsink fins.



### CAUTION

To prevent thermal failure or component damage, do not move the heatsink once the bottom of its base plate touches the top of the processor. Excessive heatsink movement can cause the thermal grease to smear and become uneven. Voids in the compound can adversely impact the transfer of heat away from the processor.

Install the heatsink:

- a. Review the heatsink screw numbering on the [heatsink label](#).
- b. Note the **Front of server** text on the heatsink label to correctly orient the heatsink over the processor socket.
- c. Position the heatsink on top of the processor, ensuring that it is properly seated before securing the screws.

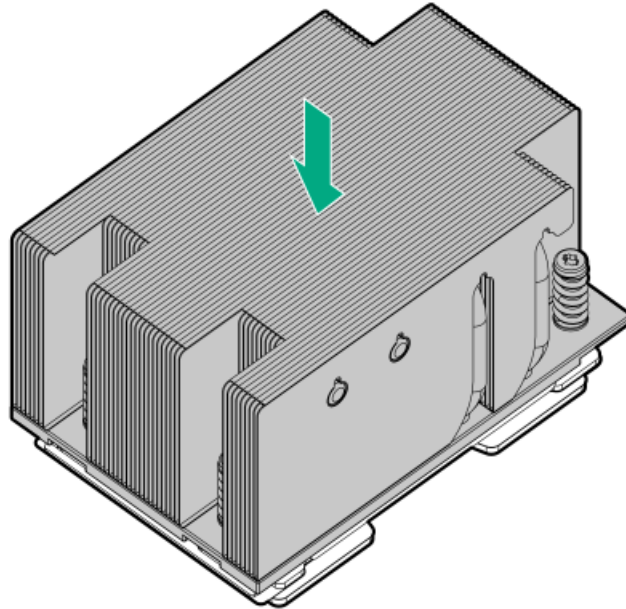

- d. Apply a pre-torque of 0.29 N-m (2.60 lbf-in) to the heatsink screw number 1 (callout 1) using a torque screwdriver.

Tighten the heatsink screws in the sequence specified on the [heatsink label](#).

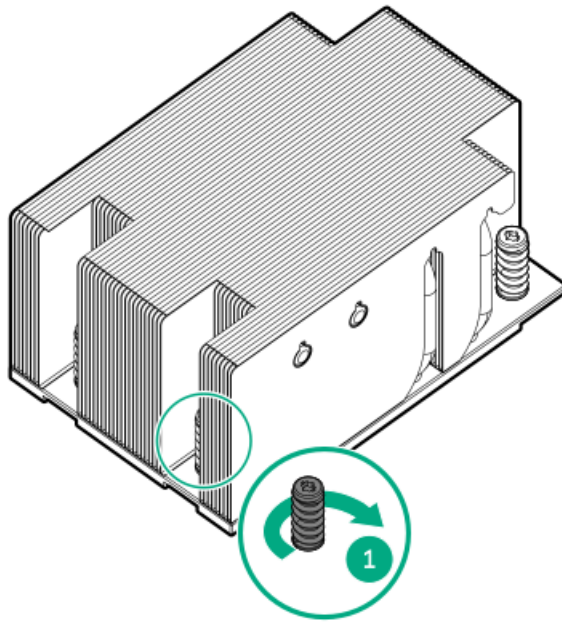

e. When using a torque screwdriver to tighten the heatsink screws, set a torque between 1.24 N-m (11 lbf-in) to 1.47 N-m (13 lbf-in).

f. Use a torque screwdriver to tighten the heatsink screw numbers 2, 3, 4 and 1 (callouts 2, 3, 4, and 1).

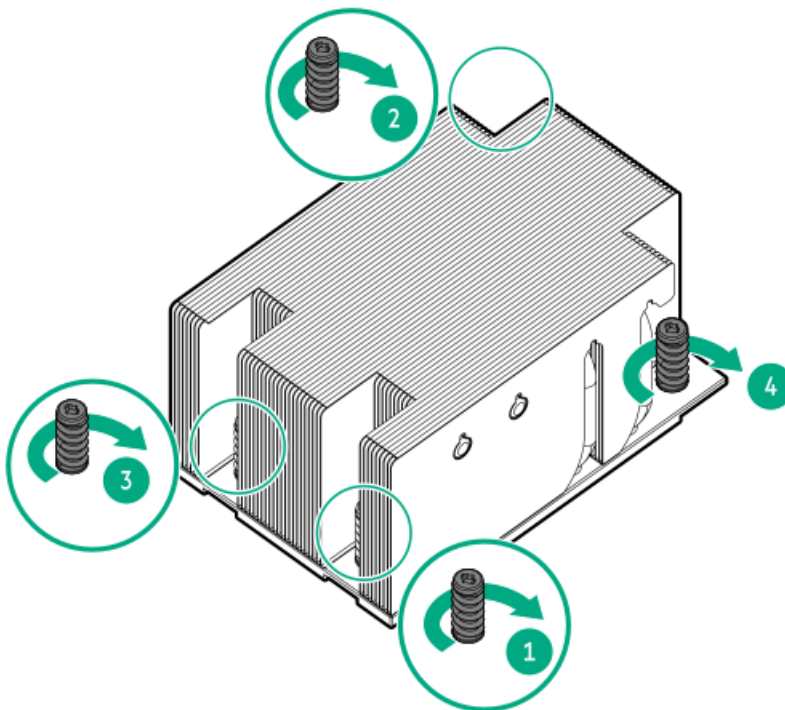

6. Install the air baffle.

7. Install the access panel.

8. Install the server into the rack.

9. Connect all peripheral cables to the server.

10. Connect each power cord to the server.

11. Connect each power cord to the power source.

12. [Power up the server.](#)
13. If removed, install the front bezel.
14. [Reconfigure the system date and time settings.](#)

## Results

The replacement procedure is complete.

## Reconfiguring the system date and time settings

### Procedure

1. Access the UEFI System Utilities. During POST, press **F9**.
2. From the System Utilities screen, select System Configuration > BIOS/Platform Configuration (RBSU) > Date and Time.
3. Select a setting, and then complete your entry.
  - Date (mm-dd-yyyy)—Enter the date in a month-day-year (mm-dd-yyyy) format.
  - Time (hh:mm:ss)—Enter the time in a 24-hour format (hh:mm:ss) format.
  - Hour Format—Select either a 12- or 24-hours format.
  - Time Format
    - Coordinated Universal Time (UTC)—Calculates the time stored in the hardware real-time clock (RTC) from the associated Time Zone setting.
    - Local Time—Removes the use of the Time Zone setting. This option is useful for addressing interaction issues in Windows operating systems set in legacy BIOS boot mode.
  - Time Zone—Select the time zone for the system.
  - Daylight Savings Time
    - Enabled—Adjusts the local time displayed by one hour for Daylight Savings Time.
    - Disabled—Does not adjust the local time displayed for Daylight Savings Time.
4. To confirm and save the settings, press **F12**.

The server automatically reboots.

## Removing and replacing the power distribution board (PDB)

### Prerequisites

Before you perform this procedure, make sure that you have a T-15 Torx screwdriver available.

### About this task



### CAUTION

Before replacing a DIMM, backplane, expansion card, riser board, or other similar PCA components due to a perceived hardware error, make sure first that the component is firmly seated in the slot.

When installing the replacement component:

- Observe antistatic precautions.
- Handle the PCA only along the edges.
- Do not touch the components and connectors on the PCA.
- Do not bend or flex the PCA.

## Procedure

1. If installed, remove the front bezel.
2. Power down the server.
3. Remove all power:
  - a. Disconnect each power cord from the power source.
  - b. Disconnect each power cord from the server.
4. Disconnect all peripheral cables from the server.
5. Remove the server from a four-post rack.
6. Place the server on a flat, level work surface.
7. If the server is using Flexible Slot power supplies, remove all Flexible Slot power supplies.
8. Remove the access panel.
9. Remove the air baffle.
10. Disconnect all cables from the PDB.
11. Remove the PDB tray from the power supply cage:
  - a. Use the blue touchpoint to pivot the latch open.
  - b. Lift the tray away from the power supply cage.

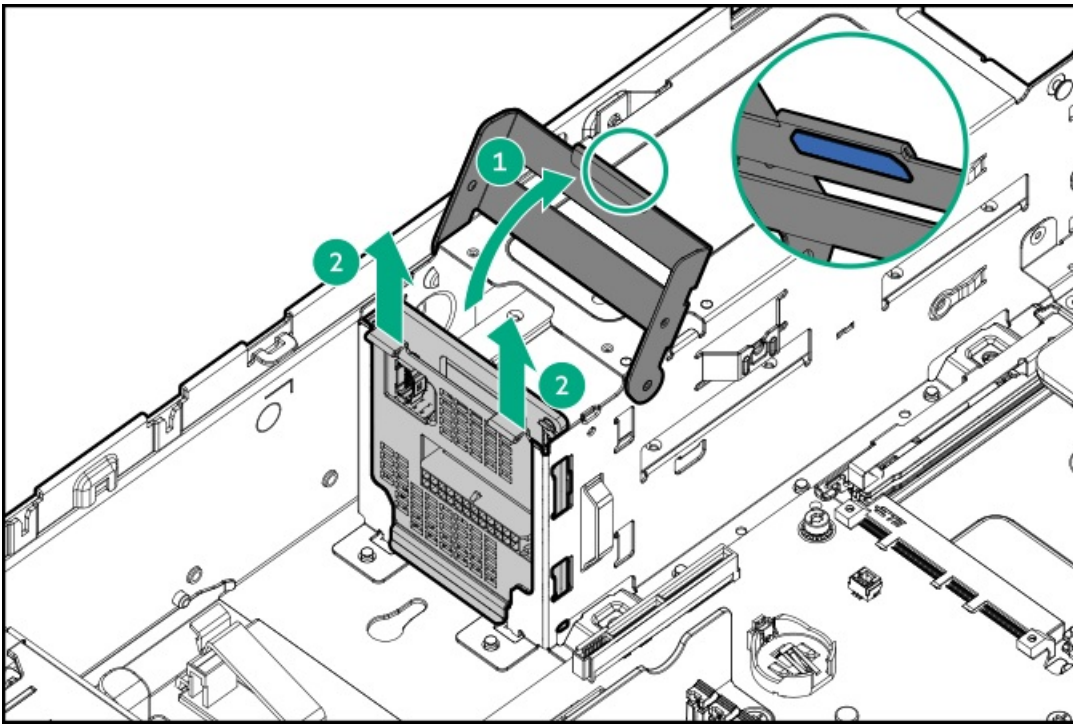

12. Remove the PDB:

- a. Remove the screws.

Retain the screws for future use.

- b. Lift the PDB up to release the tray hooks from the PDB, and then remove the PDB.

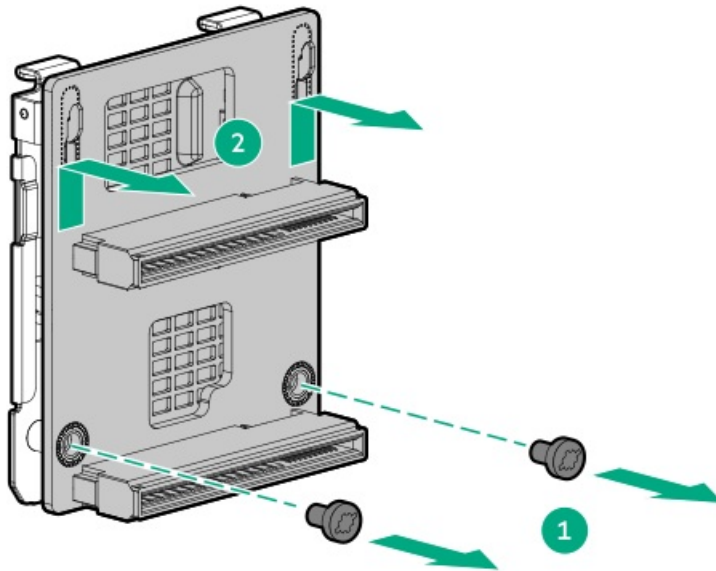

**Results**

The removal procedure is complete. To replace the component, reverse this procedure.

**System board replacement**

Subtopics

[Removing the system board](#)

[Installing the system board](#)

[Re-entering the server serial number and product ID](#)

## Removing the system board

### Prerequisites



#### CAUTION

Be sure to have the BitLocker recovery key/password prior to replacing the system board. If you do not have the key/password, you will need to reinstall the OS.

- [Perform a backup of critical server data.](#)
- Before you perform this procedure, make sure that you have the following items available:
  - T-20 Torx screwdriver
  - T-15 Torx screwdriver
  - Alcohol wipe

### About this task



#### WARNING

To reduce the risk of personal injury from hot surfaces, allow the drives and the internal system components to cool before touching them.



#### CAUTION

A discharge of static electricity from a finger or other conductor might damage system boards or other static-sensitive devices. To prevent damage, observe [antistatic precautions](#).

### Procedure

1. If installed, [remove the front bezel](#).
2. [Power down the server](#).
3. Remove all power:
  - a. Disconnect each power cord from the power source.
  - b. Disconnect each power cord from the server.
4. Disconnect all peripheral cables from the server.
5. [Remove the server from the rack](#).
6. Place the server on a flat, level work surface.
7. [Remove the access panel](#).
8. [Remove the air baffle](#).
9. Disconnect all cables from the iLO service port, ambient temperature sensor, expansion cards, riser boards, drive backplane, and power distribution board.
10. [Remove all DIMMs](#).
11. Remove the DIMM guards.

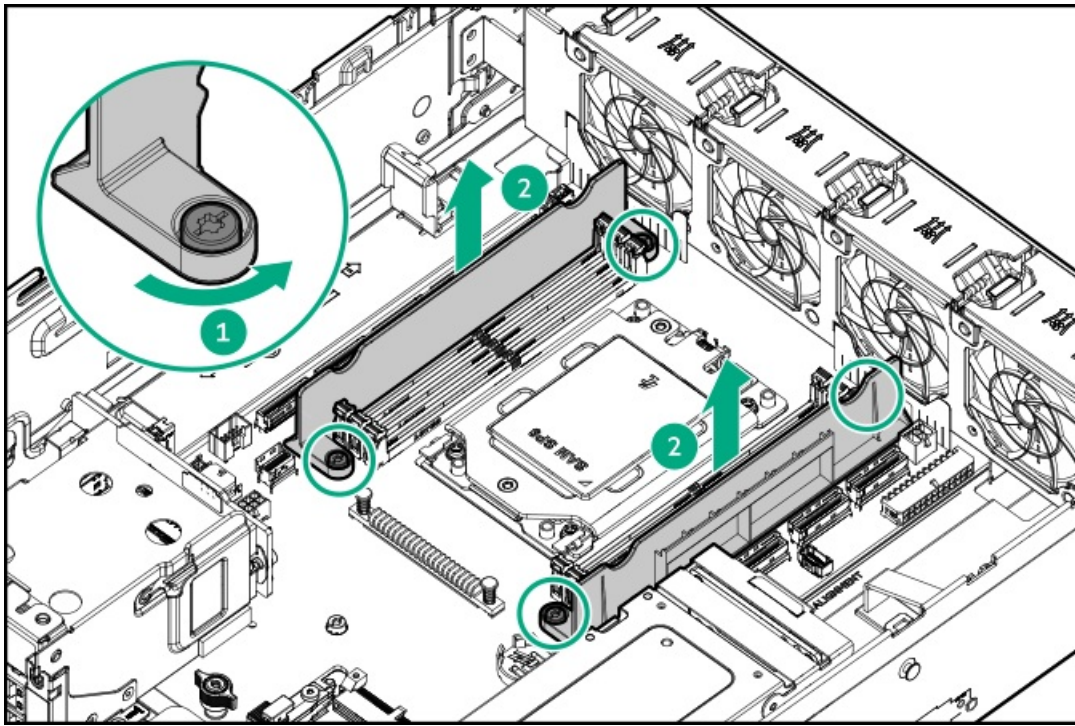

12. Remove the three-slot riser cage.
13. Remove the drive base cage.
14. Remove all fans.
15. If installed, remove the following components:

- Type-o storage controller
- OCP 3.0 NIC
- HPE NS204i-u Boot Device
- RJ45-serial port cable
- Energy pack
- Chassis intrusion detection switch

16. Allow all internal system components to cool before continuing.

17.  **CAUTION**

To prevent mechanical damage or depositing oil on your hands or other contaminants to the heatsink contact surface, hold the heatsink only by the edge of its base plate. Do not touch the heatsink fins.

Remove the heatsink:

- a. Review the heatsink screw numbering on the heatsink label.
- b. Use a T-20 Torx screwdriver to loosen one pair of diagonally opposite heatsink screws (callouts 4 and 3), and then loosen the other pair of heatsink screws (callouts 2 and 1).

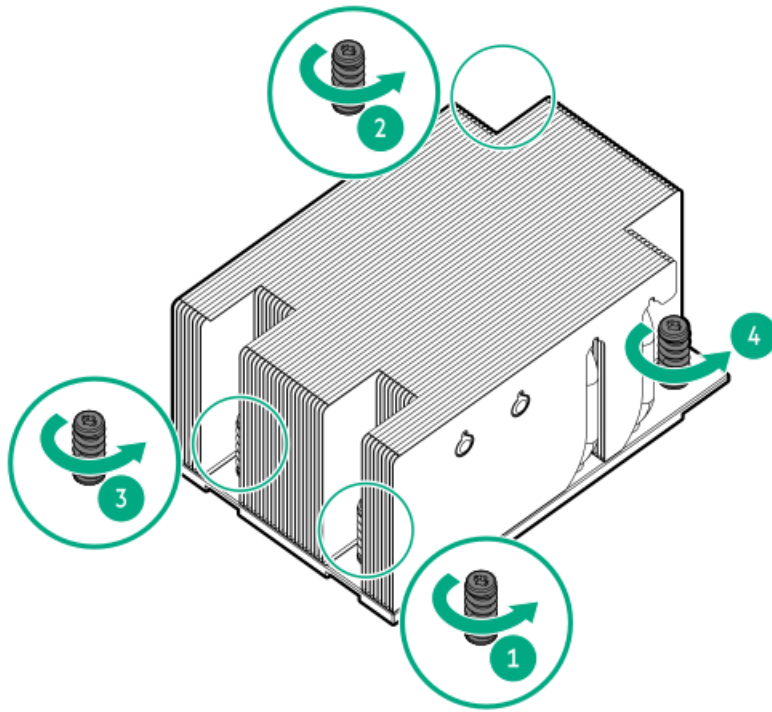

18. Lift the heatsink away from the processor socket.

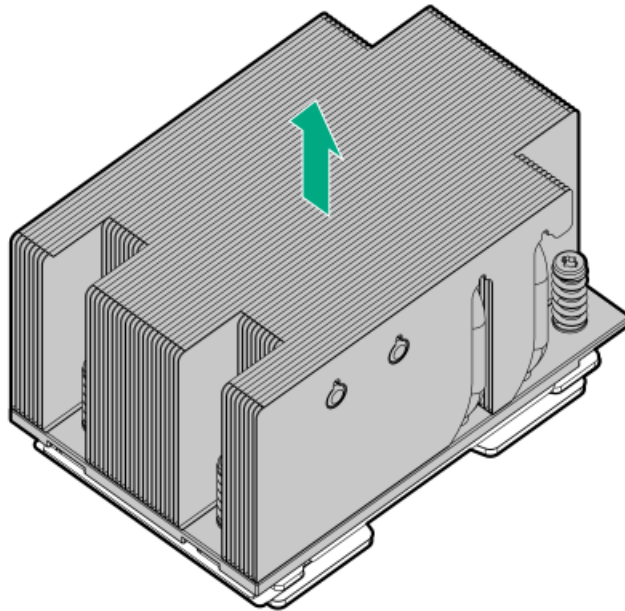

19. Place the heatsink on a flat work surface with its contact side facing up.

20. Use an alcohol wipe to remove the existing thermal grease from the heatsink and processor.

Allow the alcohol to evaporate before continuing.

21. Remove the processor:

- a. While holding the sides of the retention frame, loosen the frame screws (callouts 1, 2, and 3) in the sequence specified on the frame.

This retention frame is spring-loaded. After the screws are loosened enough, hold the retention frame as it automatically pivots to a vertical position (callout 4).



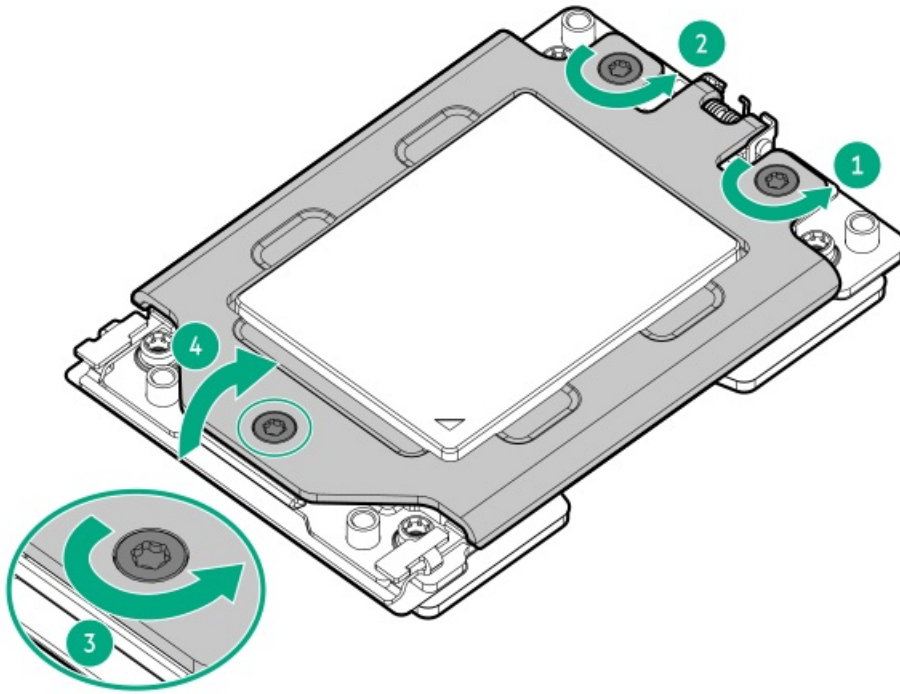

b. Hold the lift tabs and pivot the rail frame to the vertical position (callout 1).

c. Slide the processor out of the rail frame (callout 2).



**CAUTION**

The pins on the processor socket and on the processor are very fragile and easily damaged . To avoid component damage, do not touch these pins. Any damage to them might require replacing the system board and/or processor.

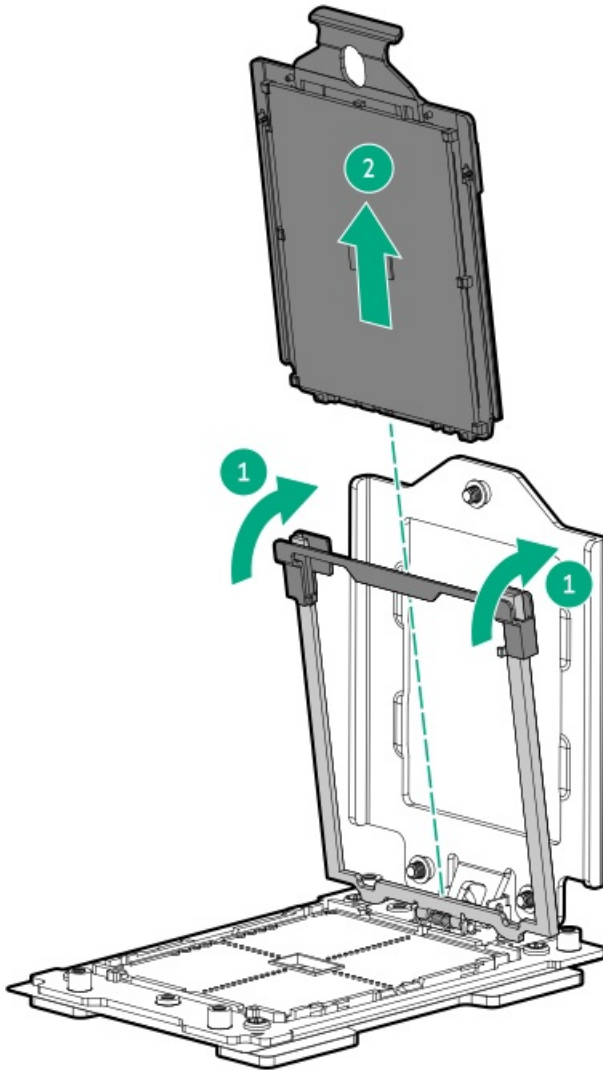

22. Do not touch the pin field on the socket and the processor contacts.

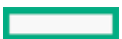
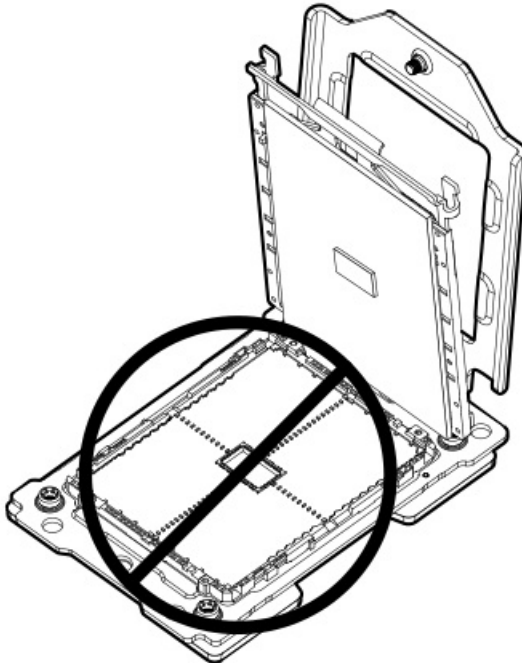



23. Remove the system board tray from the chassis:

- a. Loosen the system board thumbscrews. Use a T-15 Torx screwdriver if necessary.
- b. Pull the system board tray out of the chassis.

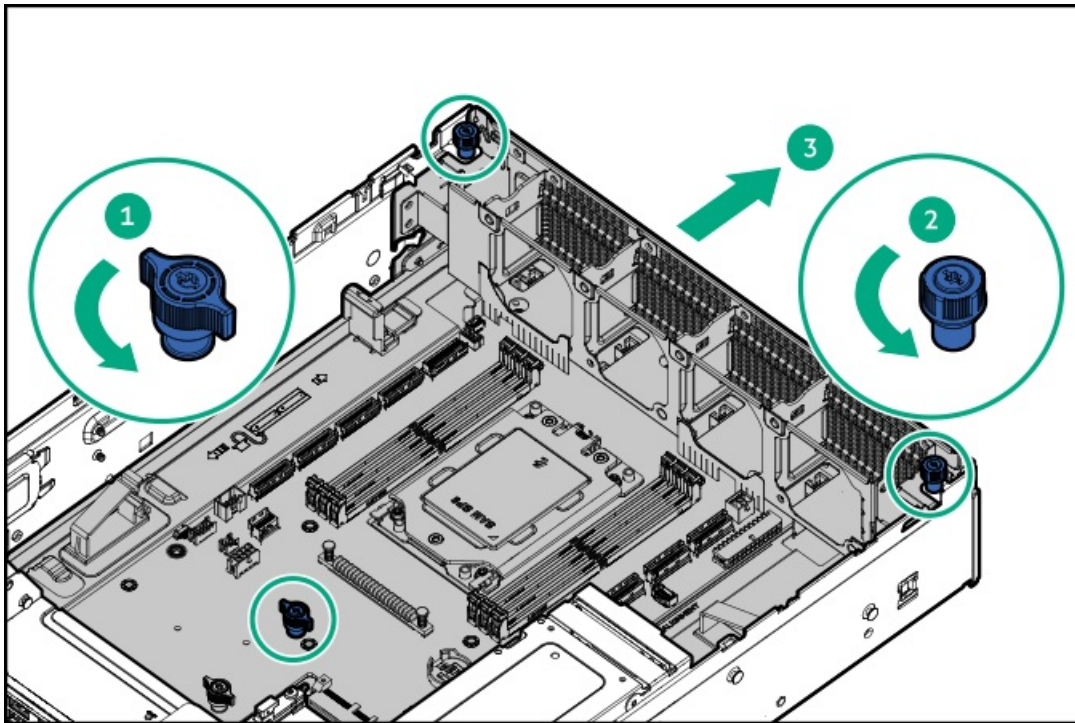

24. Remove the system board:

- a. Remove the system board screws.

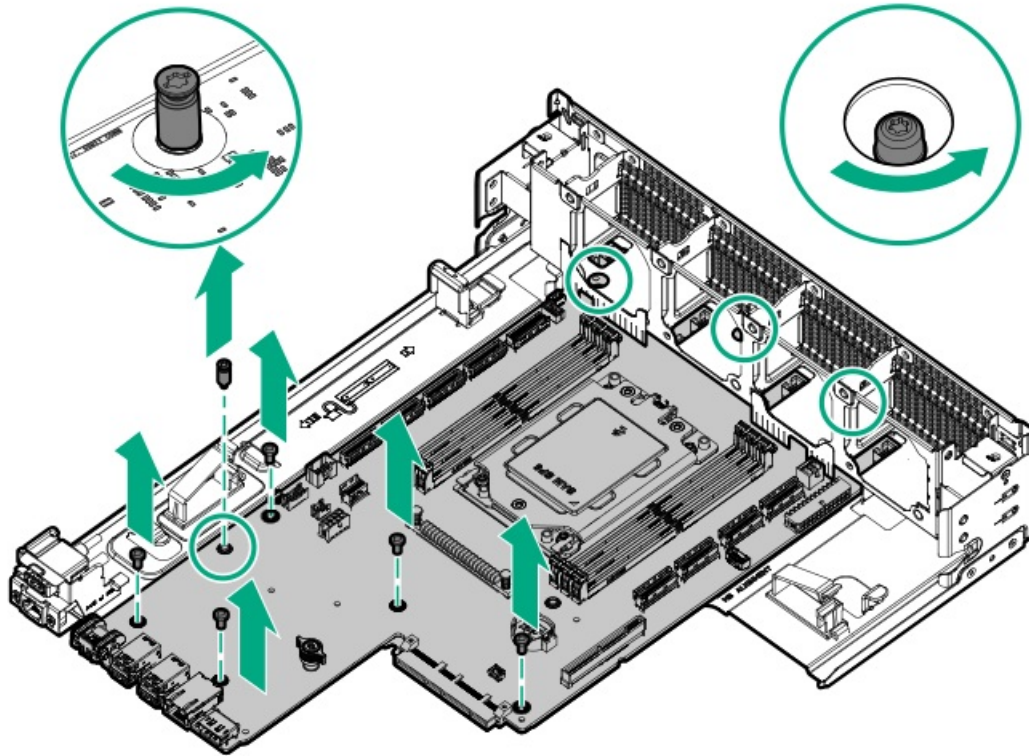

- b. Use the system board thumbscrew to slide the system board forward and then lift the system board.

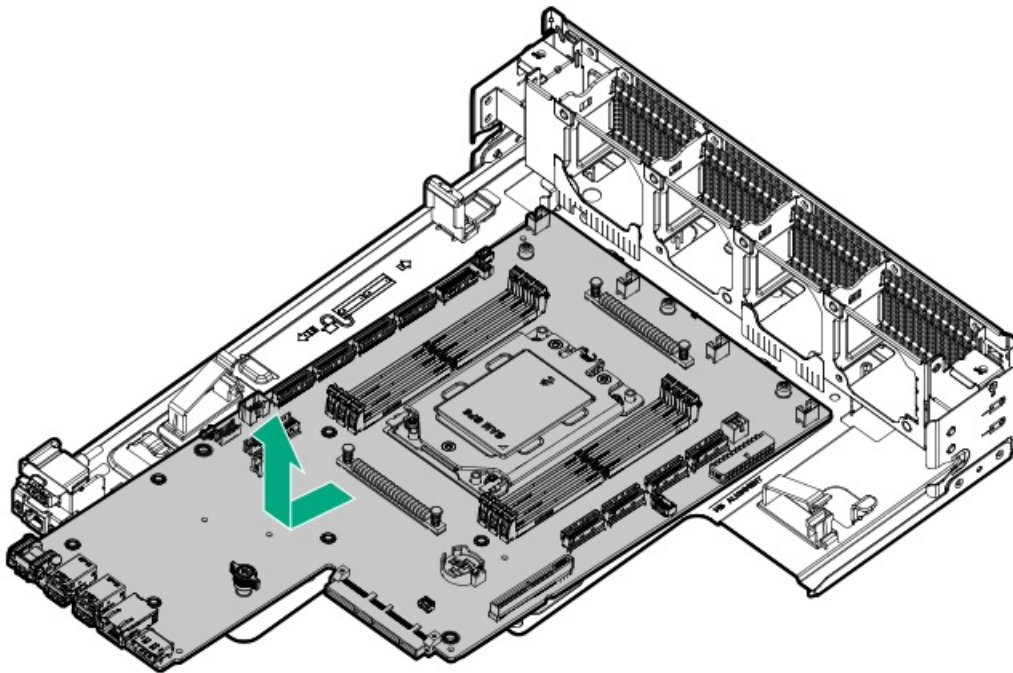

## Installing the system board

### Prerequisites





#### CAUTION

Be sure to have the BitLocker recovery key/password prior to replacing the system board. If you do not have the key/password, you will need to reinstall the OS.



#### CAUTION

Do not use One-button secure erase (OBSE). OBSE should only be used to decommission or repurpose a system. **This option erases all data. Be sure to disconnect any drives, SANs, NAS, or other shared/external storage devices that you do not want erased.**

Before you perform this procedure, make sure that you have the following items available:

- T-20 Torx screwdriver
- T-15 Torx screwdriver
- Thermal grease (spare part number: 777298-001)

### About this task



#### CAUTION

A discharge of static electricity from a finger or other conductor might damage system boards or other static-sensitive devices. To prevent damage, observe [antistatic precautions](#).

### Procedure

1. Install the new system board:
  - a. Slide the system board towards the fan cage to position it on the system board tray.

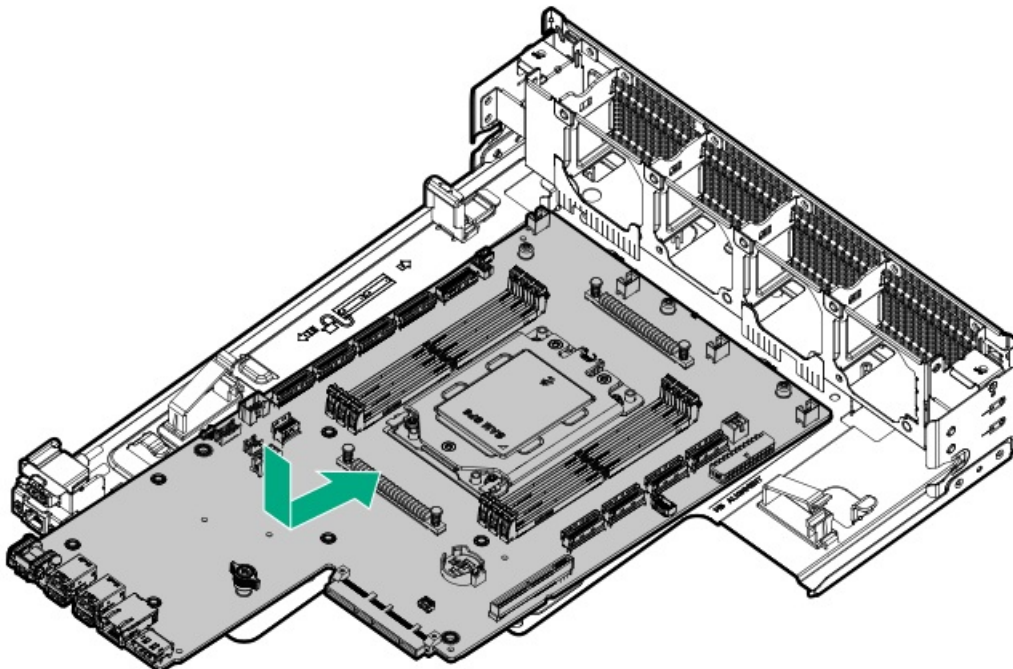

- b. Install the system board screws.

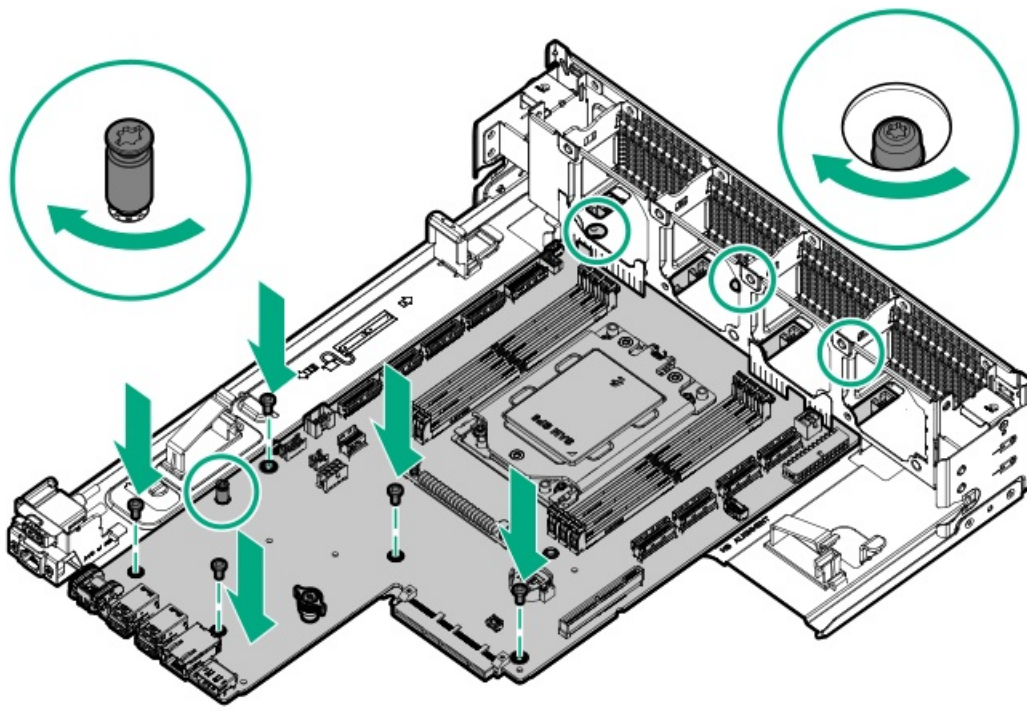

2. Install the system board tray into the chassis:
  - a. Slide the system board tray into the chassis.
  - b. Tighten the system board thumbscrews.

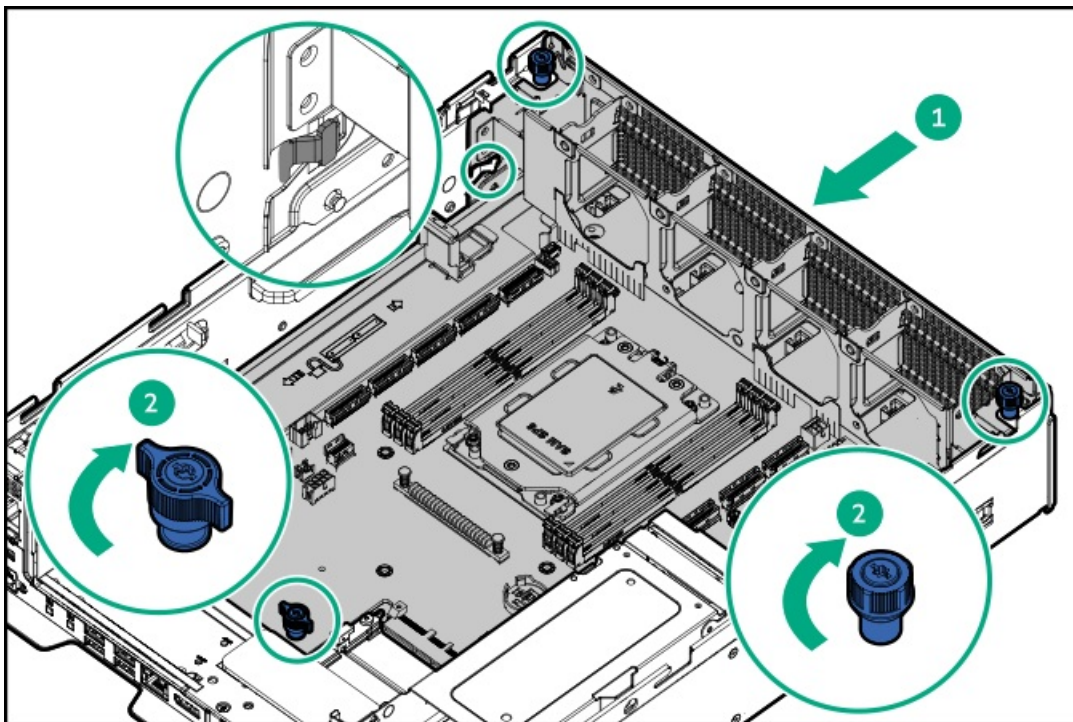

3. Remove the external cap:
  - a. While holding the sides of the retention frame, loosen the frame screws (callouts 2, 3, and 4) in the sequence specified on the frame.  
 This retention frame is spring-loaded. After the screws are loosened enough, hold the retention frame as it automatically pivots to a vertical position (callout 4).



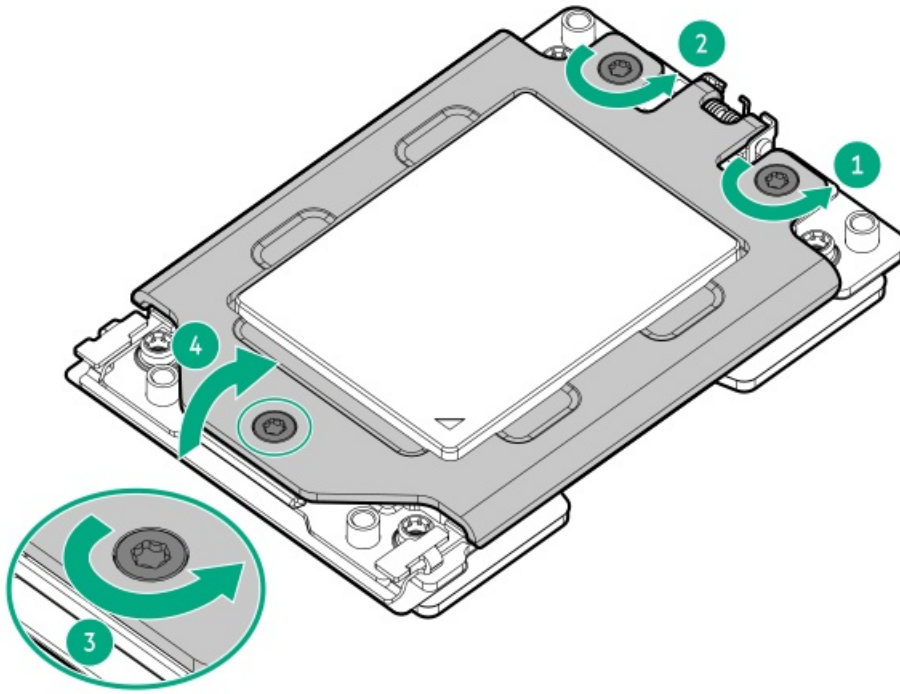

b. Hold the lift tabs and pivot the rail frame to the vertical position (callout 1).

c. Slide the external cap out of the rail frame (callout 2).

Retain the external cap for future use.

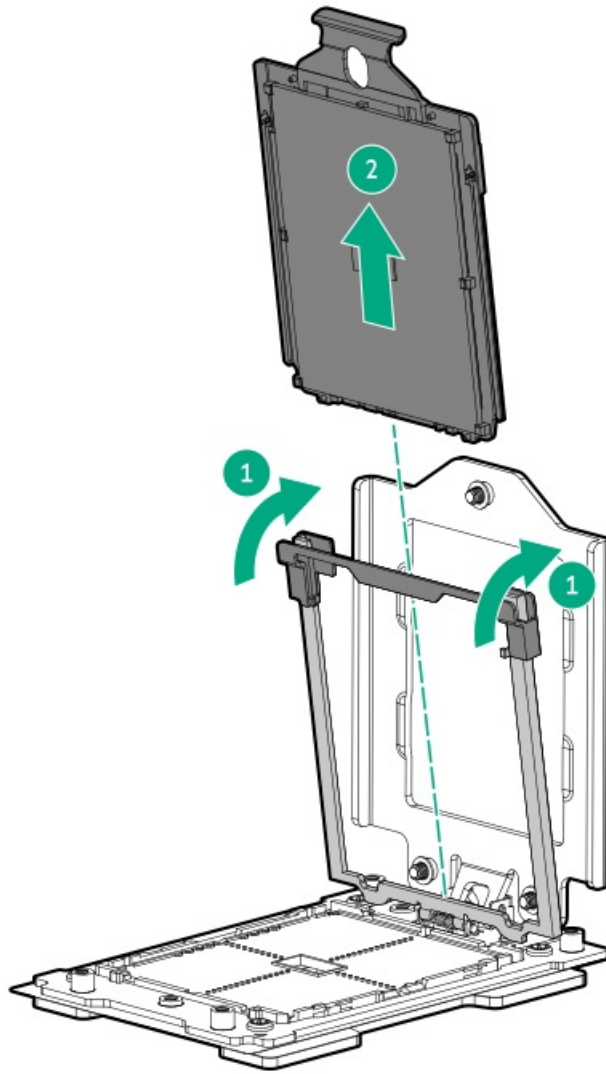

4. Install the processor:

- a. Hold the processor by its carrier handle and slide the processor into the rail frame until it engages with a click sound.



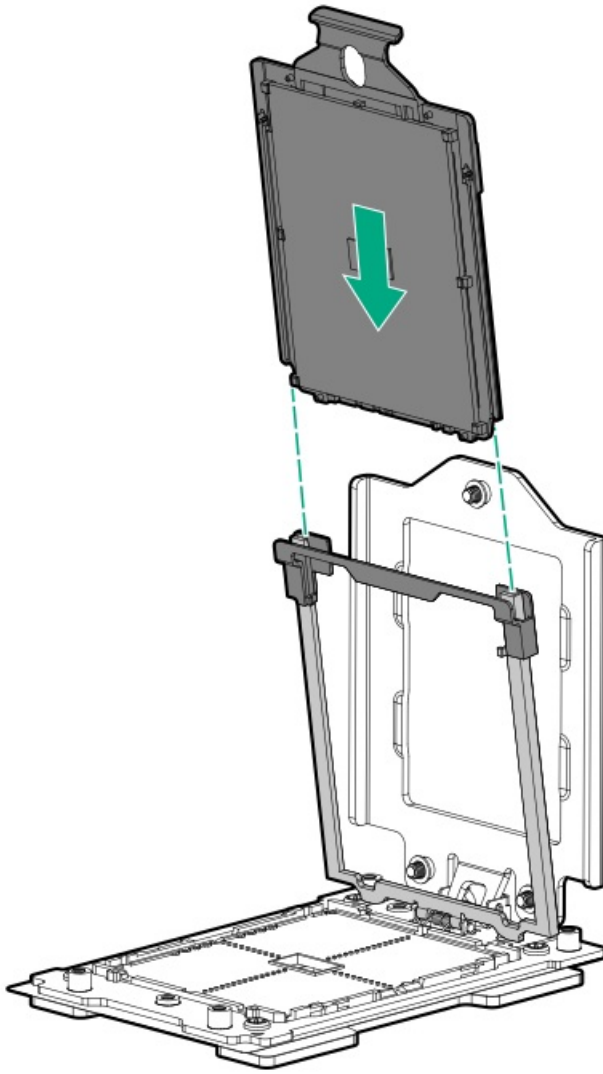

5. Do not touch the pin field on the socket and the processor contacts.

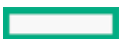
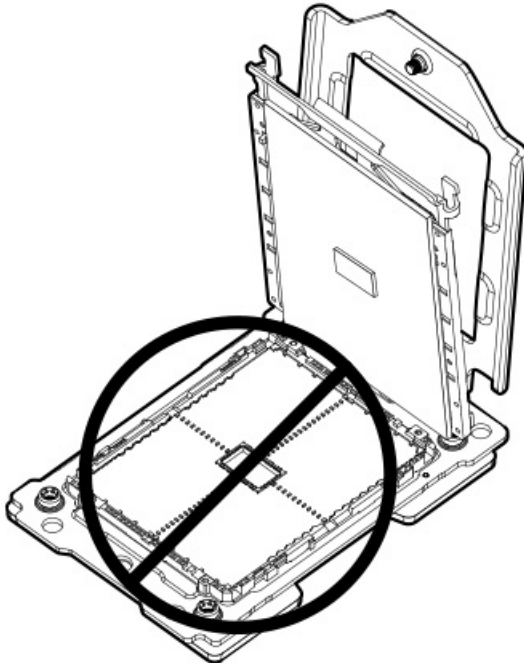

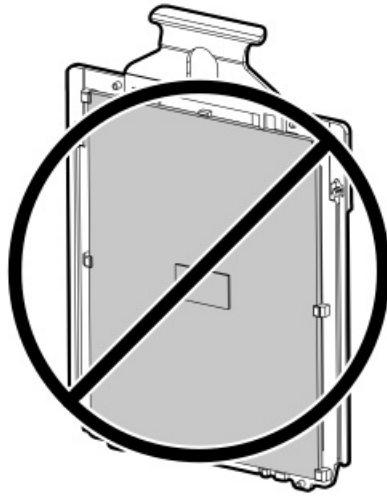

6. Hold the lift tabs and pivot the rail frame to the closed position.

A click sound indicates that the rail frame is properly engaged.

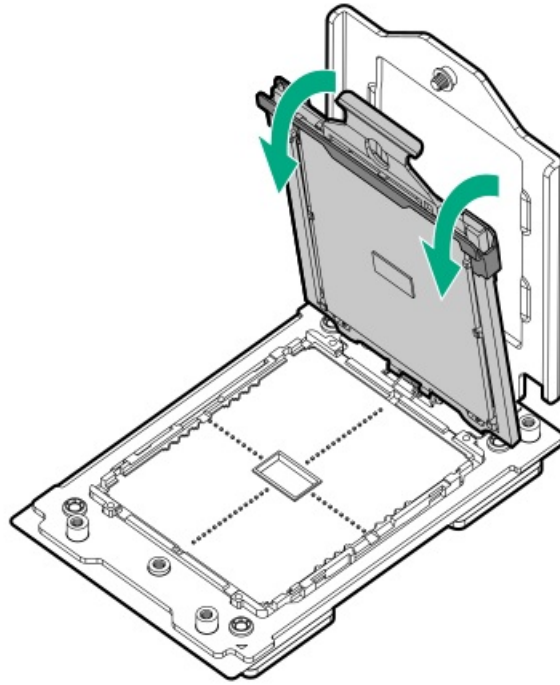

7. Close the retention frame:

- a. When using a torque screwdriver to tighten the retention frame screws, set a torque between 1.23 N-m (10.89 lbf-in) to 1.48 N-m (13.10 lbf-in).
- b. Pivot the spring-loaded retention frame downward and hold it down (callout 1).
- c. Tighten the retention frame screws (callouts 2, 3, and 4) in the sequence specified on the frame.

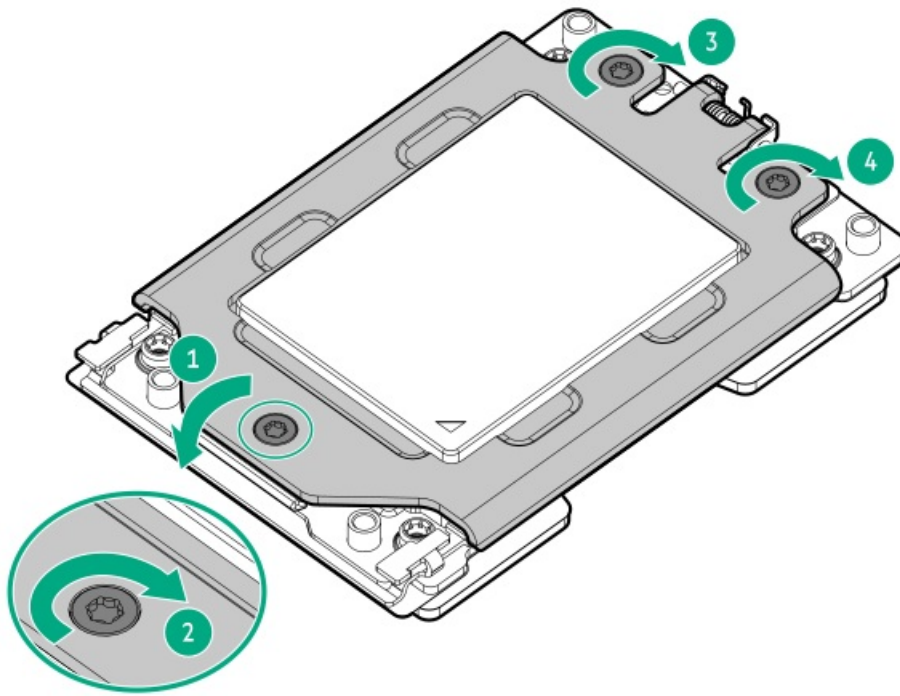

8. If you are using the same heatsink, apply the full content of the thermal grease syringes on top of the processor. Follow the pattern shown in the following image.

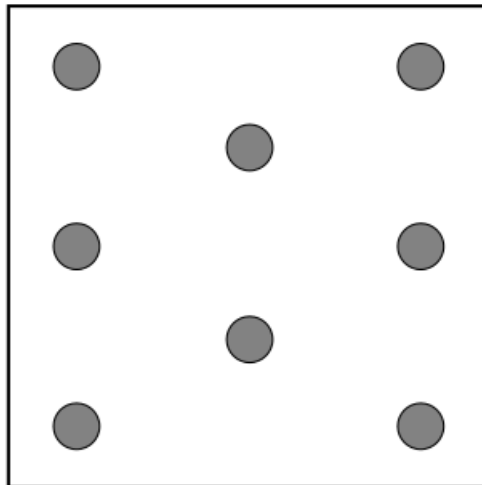

9. **CAUTION**

To prevent mechanical damage or depositing oil on your hands or other contaminants to the heatsink contact surface, hold the heatsink only by the edge of its base plate. Do not touch the heatsink fins.

**CAUTION**

To prevent thermal failure or component damage, do not move the heatsink once the bottom of its base plate touches the top of the processor. Excessive heatsink movement can cause the thermal grease to smear and become uneven. Voids in the compound can adversely impact the transfer of heat away from the processor.

Install the heatsink:

- a. Review the heatsink screw numbering on the [heatsink label](#).
- b. Note the **Front of server** text on the heatsink label to correctly orient the heatsink over the processor socket.
- c. Position the heatsink on top of the processor, ensuring that it is properly seated before securing the screws.

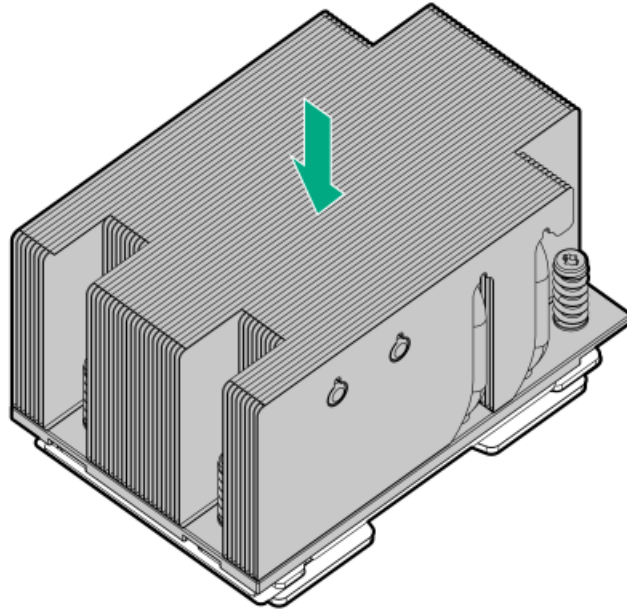

- d. Apply a pre-torque of 0.29 N-m (2.60 lbf-in) to the heatsink screw number 1 (callout 1) using a torque screwdriver.  
Tighten the heatsink screws in the sequence specified on the [heatsink label](#).

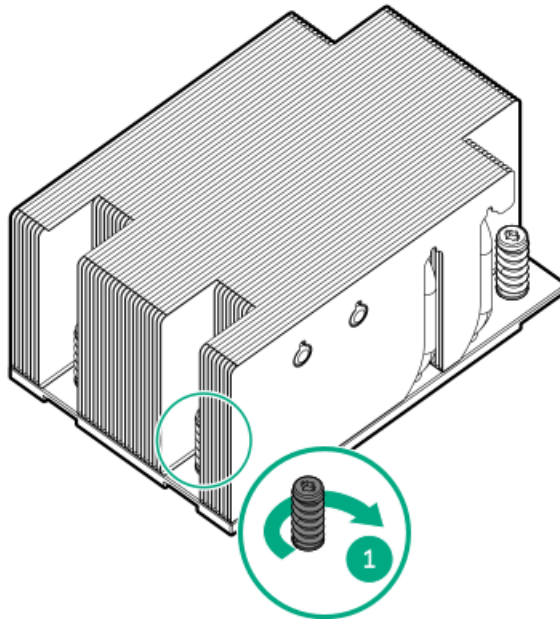

- e. When using a torque screwdriver to tighten the heatsink screws, set a torque between 1.24 N-m (11 lbf-in) to 1.47 N-m (13 lbf-in).
- f. Use a torque screwdriver to tighten the heatsink screw numbers 2, 3, 4 and 1 (callouts 2, 3, 4, and 1).

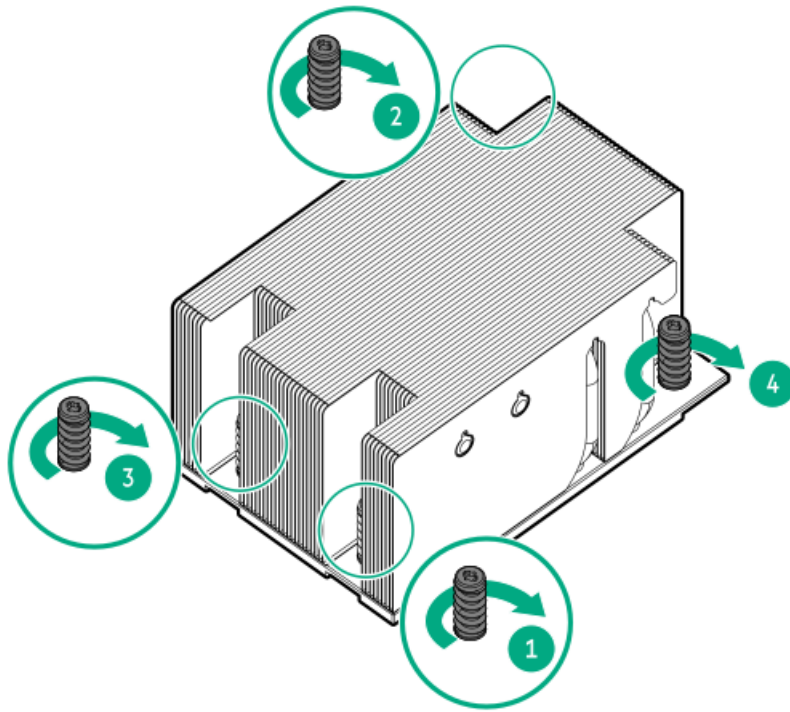

10. Install all removed components on the new system board.
11. Install the air baffle.
12. Install the access panel.
13. Install the server into the rack.
14. Connect all peripheral cables to the server.
15. Connect each power cord to the server.
16. Connect each power cord to the power source.
17. Power up the server.
18. If removed, install the front bezel.
19. Make sure all firmware, including option cards and embedded devices, is updated to the same versions to ensure that the latest drivers are being used.
20. Re-enter any Secure Boot keys that were previously added in the Secure Boot configuration.
21. Re-enter the server serial number and product ID.
22. Reconfigure the system date and time settings.
23. See the applicable OS documentation for procedures and recommendations on restoring the OS and accessing drive data.



#### CAUTION

(For Microsoft Windows only) After replacing the system board, we recommend using BitLocker Recovery to restore the OS and access drive data. The recovery key/password previously generated during the initial server installation and BitLocker setup is required to enter Recovery Mode.

For more information about BitLocker Recovery, see the [Microsoft website](#).

24. If the front bezel filter is installed, restore the iLO filter change timer setting using the iLO backup and restore function.

For more information, see the iLO user guide (<https://www.hpe.com/support/hpeilodocs-quicklinks>).

## Results

The replacement procedure is complete.

## Re-entering the server serial number and product ID

### About this task

After replacing the system board, re-enter the system serial number and product ID, and then configure the date and time settings.

### Procedure

1. Access the UEFI System Utilities. During POST, press **F9**.
2. From the System Utilities screen, select **System Configuration > BIOS/Platform Configuration (RBSU) > Advanced Options > Advanced Service Options**.
3. Select **Serial Number**, and then press **Enter**.

The following warning appears:

```
The serial number is modified by qualified service personnel and must
match the serial number located on the chassis.
```

4. Click **OK**.
5. Type the serial number, and then press **Enter**.
6. Select **Product ID**, and then press **Enter**.

The following warning appears:

```
Product ID is modified only by qualified service personnel. This value
must match the product ID located on the chassis.
```

7. Type the product ID, and then press **Enter**.
8. From the System Utilities screen, select **System Configuration > BIOS/Platform Configuration (RBSU) > Date and Time**.
9. Reconfigure the system date and time settings.
10. To confirm and save the settings, press **F12**.

The server automatically reboots.

## Results

The installation procedure is complete.

## System battery replacement

If the server no longer automatically displays the correct date and time, then replace the battery that provides power to the real-time clock. Under normal use, battery life is 5–10 years.

### Subtopics

[System battery information](#)

[Removing and replacing the system battery](#)

## System battery information

The server contains an internal lithium manganese dioxide, a vanadium pentoxide, or an alkaline battery that provides power to the real-time clock.



### WARNING

If this battery is not properly handled, a risk of fire or burning exists. To reduce the risk of personal injury:

- Do not attempt to recharge the battery.
- Do not expose the battery to temperatures higher than 60°C (140°F).
- Do not expose the battery to low air pressure as it might lead to explosion or leakage of flammable liquid or gas.
- Do not disassemble, crush, puncture, short external contacts, or dispose of the battery in fire or water.

## Removing and replacing the system battery

### Prerequisites

Before you perform this procedure, make sure that you have a small flat-bladed, nonconductive tool available.

### About this task

[https://sketchfab.com/models/6f2a2a1a5c8540cb9a3adc740b055e0e/embed?ui\\_infos=0&ui\\_watermark=0&ui\\_help=0&ui\\_vr=0&ui\\_settings=0&ui\\_inspector=0&ui\\_hint=2&ui\\_animations=0&ui\\_color=01a982&ui\\_theme=dark&autostart=1&camera=0](https://sketchfab.com/models/6f2a2a1a5c8540cb9a3adc740b055e0e/embed?ui_infos=0&ui_watermark=0&ui_help=0&ui_vr=0&ui_settings=0&ui_inspector=0&ui_hint=2&ui_animations=0&ui_color=01a982&ui_theme=dark&autostart=1&camera=0)



### CAUTION

A discharge of static electricity from a finger or other conductor might damage system boards or other static-sensitive devices. To prevent damage, observe [antistatic precautions](#).



### IMPORTANT

After replacing the system battery and applying power, wait for 10 minutes before powering on the server. This lead time is required for the server to reset and reinitialize the iLO configuration settings stored in SRAM.

### Procedure

1. If installed, [remove the front bezel](#).
2. [Power down the server](#).
3. Remove all power:
  - a. Disconnect each power cord from the power source.
  - b. Disconnect each power cord from the server.
4. Disconnect all peripheral cables from the server.

5. Remove the server from a four-post rack.
6. Place the server on a flat, level work surface.
7. Remove the access panel.
8. Remove the air baffle.
9. Remove the three-slot riser cage.
10. Locate the battery on the system board.
11. Remove the system battery:
  - a. Use a small flat-bladed, nonconductive tool to press the battery latch.
  - b. Remove the system battery from the socket.

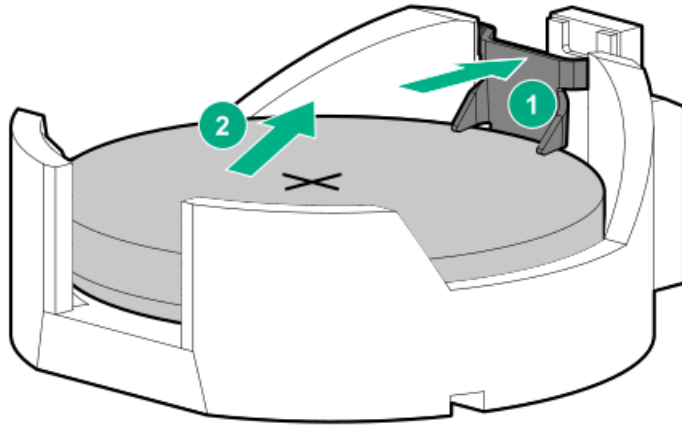

12. Install the system battery:
  - a. With the side of the battery showing the "+" sign facing up, insert the battery into the socket.
  - b. Press the system battery down until it clicks into place.

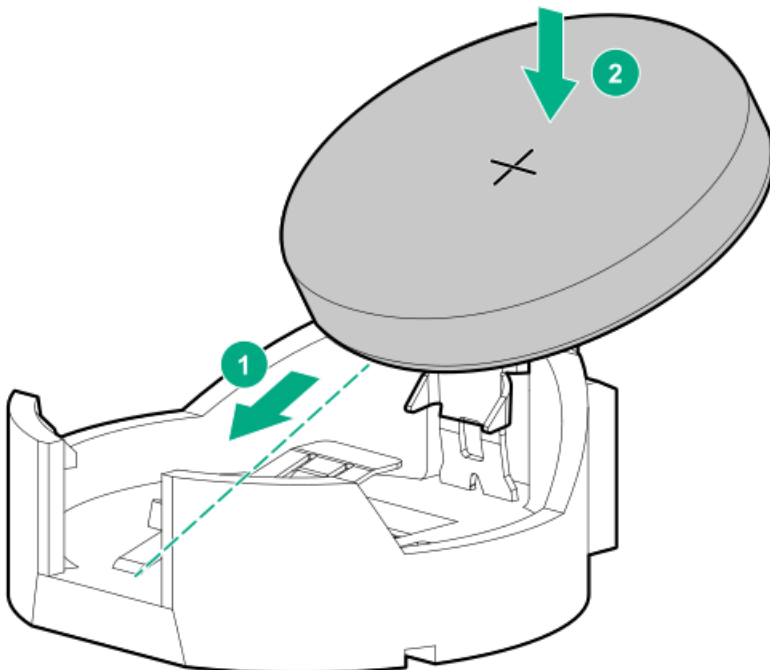

13. Install the three-slot riser cage.
14. Install the air baffle.
15. Install the access panel.
16. Install the server into the rack.
17. Connect all peripheral cables to the server.
18. Connect each power cord to the server.
19. Connect each power cord to the power source.
20. Wait for 10 minutes for the server to reset and reinitialize the iLO configuration settings stored in SRAM.



#### IMPORTANT

If iLO security is disabled, the configuration will not be restored. To restore the configuration manually, see <https://www.hpe.com/support/hpeilodocs-quicklinks>.

21. Power up the server.
22. If removed, install the front bezel.
23. Properly dispose of the old battery.

For more information about proper battery disposal, contact an authorized reseller or an authorized service provider.

## Results

The installation procedure is complete.

## Troubleshooting

### Subtopics

[NMI functionality](#)

[Troubleshooting resources](#)

## NMI functionality

An NMI crash dump enables administrators to create crash dump files when a system is not responding to traditional debugging methods.

An analysis of the crash dump log is an essential part of diagnosing reliability problems, such as hanging operating systems, device drivers, and applications. Many crashes freeze a system, and the only available action for administrators is to cycle the system power. Resetting the system erases any information that could support problem analysis, but the NMI feature preserves that information by performing a memory dump before a hard reset.

To force the OS to initiate the NMI handler and generate a crash dump log, the administrator can use the iLO Generate NMI feature.

## Troubleshooting resources

Troubleshooting resources are available for HPE Gen11 server products in the following documents:

- Troubleshooting Guide for HPE ProLiant Gen11 servers provides procedures for resolving common problems and comprehensive

courses of action for fault isolation and identification, issue resolution, and software maintenance.

<https://www.hpe.com/info/gen11-troubleshooting>

- Integrated Management Log Messages for HPE ProLiant Gen10, Gen10 Plus, and Gen11 servers and HPE Synergy provides IML messages and associated troubleshooting information to resolve critical and cautionary IML events.

<https://www.hpe.com/info/Troubleshooting-IML-en>

## Configuration resources

Use the following resources to find documentation for configuring and managing your server.

- Some utilities might not apply to your server. For information about server compatibility with the products listed in this chapter, see the product QuickSpecs (<https://www.hpe.com/info/quickspecs>).
- Products ordered from HPE Factory Express might have already been configured with some or all the configurations in this chapter. To determine if any additional setup is required, see your HPE Factory Express order.
- For one-stop access to version-specific software and firmware documentation, including the latest product release notes, see this quick links page:

<https://www.hpe.com/support/hpeproductdocs-quicklinks>

### Subtopics

[Updating firmware or system ROM](#)

[Configuring the server](#)

[Configuring storage controllers](#)

[Deploying an OS](#)

[Configuring security](#)

[Server management](#)

[Managing Linux-based high performance compute clusters](#)

## Updating firmware or system ROM

To	Use
Download service packs	<ul style="list-style-type: none"> <li>• Service Pack for ProLiant (SPP) <a href="https://www.hpe.com/servers/spp/download">https://www.hpe.com/servers/spp/download</a></li> <li>• Get an overview of SPP and its ecosystem <a href="https://www.hpe.com/support/SPP-overview-videos-en">https://www.hpe.com/support/SPP-overview-videos-en</a></li> </ul>
Deploy service packs to a single server	Smart Update Manager (SUM) <a href="https://www.hpe.com/support/hpesmartupdatemanager-quicklinks">https://www.hpe.com/support/hpesmartupdatemanager-quicklinks</a>
Deploy service packs to multiple servers	HPE OneView <a href="https://www.hpe.com/support/hpeoneview-quicklinks">https://www.hpe.com/support/hpeoneview-quicklinks</a>
Updating iLO or system firmware in a single server or multiple servers	HPE iLO <a href="https://www.hpe.com/support/hpeilodocs-quicklinks">https://www.hpe.com/support/hpeilodocs-quicklinks</a>
<ul style="list-style-type: none"> <li>• Enable policy-based management of server or server group firmware for distributed server infrastructure</li> <li>• Monitor server compliance with a configured firmware baseline</li> <li>• Receive automatic iLO firmware updates</li> <li>• Receive baseline update alerts</li> </ul>	HPE Compute Ops Management <a href="https://www.hpe.com/support/hpe-gl-com-quicklinks">https://www.hpe.com/support/hpe-gl-com-quicklinks</a>

## Configuring the server

## To configure

## Use

### Single server (GUI)

- Intelligent Provisioning  
<https://www.hpe.com/support/hpeintelligentprovisioning-quicklinks>
- iLO remote console or web interface  
<https://www.hpe.com/support/hpeilodocs-quicklinks>
- UEFI System Utilities  
<https://www.hpe.com/support/hpeuefisystemutilities-quicklinks>
- HPE Compute Ops Management  
<https://www.hpe.com/support/hpe-gl-com-quicklinks>

### Single server (scripting)

- RESTful Interface Tool  
<https://www.hpe.com/support/restfulinterface/docs>
- Python iLO Redfish Library (python-ilorest-library)  
<https://github.com/HewlettPackard/python-ilorest-library>
- Scripting Tools for Windows Powershell  
<https://www.hpe.com/info/powershell/docs>
- iLO RESTful API  
<https://servermanagementportal.ext.hpe.com/>
- HPE Compute Ops Management API  
<https://developer.greenlake.hpe.com/>

### Multiple servers (either UI or scripting)

- HPE OneView <sup>1</sup>  
<https://www.hpe.com/support/hpeoneview-quicklinks>
- HPE Compute Ops Management  
<https://www.hpe.com/support/hpe-gl-com-quicklinks>
  - **Server settings:** Define server-specific parameters such as firmware baselines, and then apply them to server groups.
  - **Server groups:** Organize servers into custom-defined sets with associated server settings, and then apply group-specific policies to create a consistent configuration across the servers in the group.

<sup>1</sup> For servers running HPE OneView, do not use another tool, such as iLO, to delete or change certain settings. For more information about using HPE OneView and iLO to manage the same server, see the iLO user guide at <https://www.hpe.com/support/hpeilodocs-quicklinks>.

## Configuring storage controllers

Controller type	Documentation
HPE MR Gen11 controllers	<ul style="list-style-type: none"> <li>HPE MR Gen11 Controller User Guide <a href="https://hpe.com/support/MR-Gen11-UG">https://hpe.com/support/MR-Gen11-UG</a></li> <li>MR Gen11 controller configuration: <a href="https://www.hpe.com/support/MR-Gen11-configuration">https://www.hpe.com/support/MR-Gen11-configuration</a></li> <li>MR Gen11 controller RAID creation: <a href="https://www.hpe.com/support/MR-Gen11-RAID-creation">https://www.hpe.com/support/MR-Gen11-RAID-creation</a></li> </ul> <p>Configuration guides:</p> <ul style="list-style-type: none"> <li>HPE MR Storage Administrator User Guide <a href="https://www.hpe.com/support/MRSA">https://www.hpe.com/support/MRSA</a></li> <li>HPE StorCLI User Guide <a href="https://www.hpe.com/support/StorCLI">https://www.hpe.com/support/StorCLI</a></li> </ul>
Storage controller documents library	<a href="https://www.hpe.com/support/hpestoragecontrollerdocs-quicklinks">https://www.hpe.com/support/hpestoragecontrollerdocs-quicklinks</a>

## Deploying an OS

For a list of supported operating systems, see the HPE Servers Support & Certification Matrices:

<https://www.hpe.com/support/Servers-Certification-Matrices>

To	See
Deploy an OS using HPE Compute Ops Management	HPE Compute Ops Management User Guide <a href="https://www.hpe.com/support/hpe-gl-com-quicklinks">https://www.hpe.com/support/hpe-gl-com-quicklinks</a>
Deploy an OS using Intelligent Provisioning	Intelligent Provisioning user guide <a href="https://www.hpe.com/support/hpeintelligentprovisioning-quicklinks">https://www.hpe.com/support/hpeintelligentprovisioning-quicklinks</a>
Deploy an OS using iLO virtual media	iLO user guide <a href="https://www.hpe.com/support/hpeilodocs-quicklinks">https://www.hpe.com/support/hpeilodocs-quicklinks</a>
Configure the server to boot from a PXE server	UEFI System Utilities User Guide for HPE ProLiant Gen11 Servers and HPE Synergy <a href="https://www.hpe.com/support/UEFIgen11-UG-en">https://www.hpe.com/support/UEFIgen11-UG-en</a>
Configure the server to boot from a SAN	HPE Boot from SAN Configuration Guide <a href="https://www.hpe.com/info/boot-from-san-config-guide">https://www.hpe.com/info/boot-from-san-config-guide</a>

## Configuring security

To	See
Implement server security best practices.	<ul style="list-style-type: none"> <li>• HPE Compute Security Reference Guide <a href="https://www.hpe.com/info/server-security-reference-en">https://www.hpe.com/info/server-security-reference-en</a></li> <li>• HPE iLO 6 Security Technology Brief <a href="https://www.hpe.com/support/ilo6-security-en">https://www.hpe.com/support/ilo6-security-en</a></li> </ul>
Configure and use the Server Configuration Lock feature on HPE Trusted Supply Chain servers and other servers that have the Server Configuration Lock feature enabled.	Server Configuration Lock User Guide for HPE ProLiant servers and HPE Synergy <a href="https://www.hpe.com/info/server-config-lock-UG-en">https://www.hpe.com/info/server-config-lock-UG-en</a>

## Server management

To monitor	See
Single server	HPE iLO <a href="https://www.hpe.com/support/hpeilodocs-quicklinks">https://www.hpe.com/support/hpeilodocs-quicklinks</a>
Multiple servers	HPE OneView <a href="https://www.hpe.com/support/hpeoneview-quicklinks">https://www.hpe.com/support/hpeoneview-quicklinks</a>
Single or multiple servers	HPE Compute Ops Management <a href="https://www.hpe.com/support/hpe-gl-com-quicklinks">https://www.hpe.com/support/hpe-gl-com-quicklinks</a>

## Managing Linux-based high performance compute clusters

To	Use
Provision, manage, and monitor clusters.	HPE Performance Cluster Manager <a href="https://www.hpe.com/support/hpcm_manuals">https://www.hpe.com/support/hpcm_manuals</a>
Optimize your applications.	HPE Performance Analysis Tools <a href="https://www.hpe.com/info/perftools">https://www.hpe.com/info/perftools</a>
Optimize software library for low latency and high bandwidth, both on-node and off-node, for point-to-point and collective communications.	HPE Cray Programming Environment User Guide <a href="https://www.hpe.com/info/cray-pe-user-guides">https://www.hpe.com/info/cray-pe-user-guides</a>

## Component identification

This chapter describes the external and internal server features and components.

### Subtopics

Front panel components

Front panel LEDs and buttons

Component touchpoints

System board components

Riser board components

Riser slot numbering

HPE Basic Drive LED definitions

EDSFF SSD LED definitions

Drive bay numbering

Drive backplane naming

GPU numbering

Power distribution board (PDB) components

Fan numbering

Trusted Platform Module 2.0

HPE NS204i-u Boot Device components

HPE NS204i-u Boot Device LED definitions

## Front panel components

### 2 SFF drive configuration

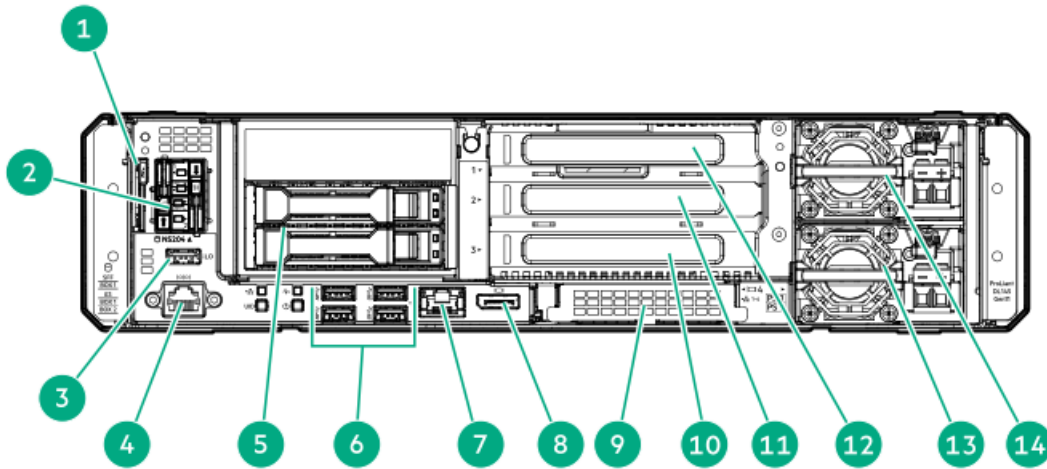

Item	Description
1	Serial number/iLO information pull tab <sup>1</sup>
2	HPE NS204i-u Boot Device (optional)
3	iLO service port
4	RJ45-serial port (optional)
5	2 SFF drives (optional) <sup>2</sup>
6	USB 3.2 Gen 1 ports
7	iLO management port
8	DisplayPort 1.1a
9	Slot 21 OCP PCIe x16
10	Slot 3 PCIe x16 (base riser)
11	Slot 2 PCIe x16 (optional stacking riser)
12	Slot 1 PCIe x16 (optional stacking riser)
13	Flexible Slot power supply 2 (optional)
14	Flexible Slot power supply 1

<sup>1</sup> The serial number/iLO information pull tab is double-sided. One side shows the server serial number and the customer asset tag label. The other side shows the default iLO account information.

<sup>2</sup> The 2 SFF drive cage option supports SAS, SATA, or U.3 NVMe drives .

#### 4 / 4 + 2 E3.S drive configuration

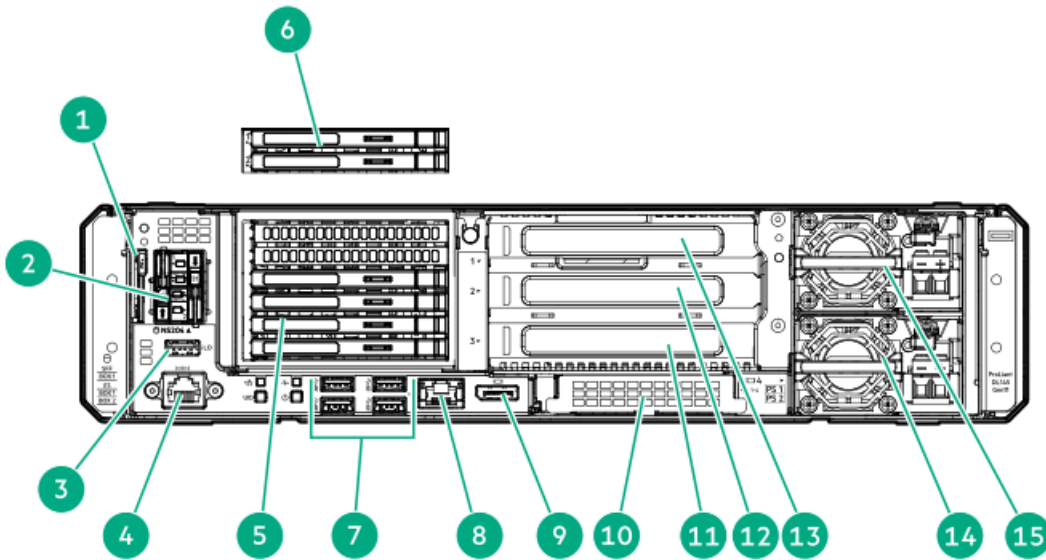

Item	Description
1	Serial number/iLO information pull tab <sup>1</sup>
2	HPE NS204i-u Boot Device (optional)
3	<u>iLO service port</u>
4	RJ45-serial port (optional)
5	4 E3.S drives (optional) <sup>2</sup>
6	2 E3.S drives (optional) <sup>2</sup>
7	USB 3.2 Gen 1 ports
8	iLO management port
9	<u>DisplayPort 1.1a</u>
10	Slot 21 OCP PCIe5 x16
11	Slot 3 PCIe5 x16 (base riser)
12	Slot 2 PCIe5 x16 (optional stacking riser)
13	Slot 1 PCIe5 x16 (optional stacking riser)
14	Flexible Slot power supply 2 (optional)
15	Flexible Slot power supply 1

- <sup>1</sup> The serial number/iLO information pull tab is double-sided. One side shows the server serial number and the customer asset tag label. The other side shows the default iLO account information.
- <sup>2</sup> The 6 E3.S stacked drive cage option supports NVMe drives.

## Subtopics

### iLO Service Port

#### Display device setup

## iLO Service Port

The Service Port is a USB port with the label **iLO** on supported servers and compute modules.

To find out if your server or compute module supports this feature, see the server specifications document at the following website: <https://www.hpe.com/info/quickspecs>.

The Service Port is a USB port with the label **iLO** on the front of the server.

To find out if your server supports this feature, see the server specifications document at the following website: <https://www.hpe.com/info/quickspecs>.

When you have physical access to a server, you can use the Service Port to do the following:

- Download the Active Health System Log to a supported USB flash drive.
  - When you use this feature, the connected USB flash drive is not accessible by the host operating system.
- Connect a client (such as a laptop) with a supported USB to Ethernet adapter to access the following:
  - iLO web interface
  - Remote console
  - iLO RESTful API
  - CLI

When you use the iLO Service Port:

- Actions are logged in the iLO event log.

- The server UID flashes to indicate the Service Port status.

You can also retrieve the Service Port status by using a REST client and the iLO RESTful API.

- You cannot use the Service Port to boot any device within the server, or the server itself.
- You cannot access the server by connecting to the Service Port.
- You cannot access the connected device from the server.

## Display device setup

This server supports DisplayPort 1.1a. Before connecting a display device to this server, review the following information:

- DisplayPort connection:

When connecting an HDMI or DVI display to the DisplayPort, use an active type adapter. Passive type adapter—marked with the DP++ symbol—is not supported.

- Display output modes:

The embedded video controller in the iLO 6 chipset does not support dual display or screen extension mode. To enable dual display mode, install a compatible PCIe5 graphics card that supports this feature in the expansion slot.

## Front panel LEDs and buttons

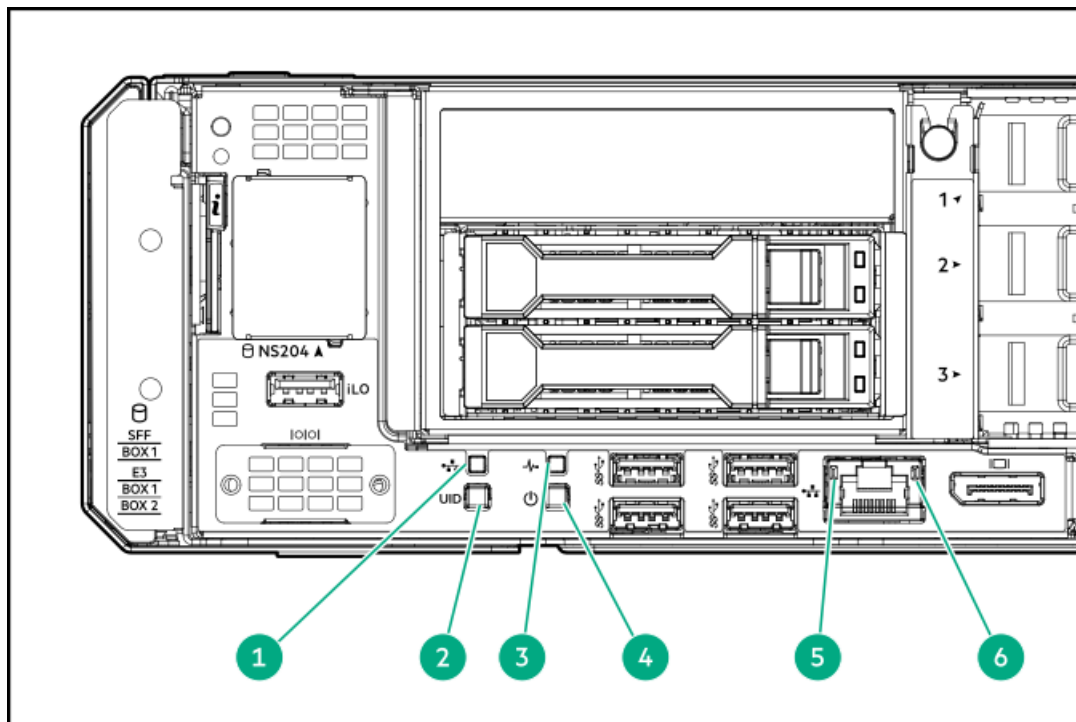

Item	Description	Status	Definition
1	NIC status LED <sup>2</sup>	Solid green	Linked to network
		Flashing green	Network active
		Off	No network activity
2	UID button/LED <sup>2</sup>	Solid blue	Activated
		Flashing blue	<ul style="list-style-type: none"> <li>1 flash per second—Remote management or firmware upgrade in progress</li> <li>4 flashes per second—iLO manual reboot sequence initiated</li> <li>8 flashes per second—iLO manual reboot sequence in progress</li> </ul>
		Off	Deactivated
		Off	Deactivated
3	Health LED <sup>2</sup>	Solid green	Normal
		Flashing green	iLO is rebooting
		Flashing amber	System degraded <sup>1</sup>
		Flashing red	System critical <sup>1</sup>
4	Power On/Standby button and system power LED <sup>2</sup>	Solid green	System on
		Flashing green	Performing power-on sequence
		Solid amber	System in standby
		Off	No power present <sup>3</sup>
5	NIC/iLO link	Solid green	Network link speed is 1000 Mb/s.
		Solid amber	Network link speed is 10/100 Mb/s.
		Off	No network link
6	NIC/iLO activity	Flashing green	Network active
		Off	No network activity

<sup>1</sup> If the health LED indicates a degraded or critical state, [review the system Integrated Management Log \(IML\)](#) or use [HPE iLO to review the system health status](#).

<sup>2</sup> When all LEDs flash simultaneously, a power fault has occurred. For more information, see [Front panel LED power fault codes](#).

<sup>3</sup> Facility power is not present, power cord is not attached, no power supplies are installed, power supply failure has occurred, or the front I/O cable is disconnected.

## Subtopics

[Server UID LED](#)

[Viewing the Server Health Summary](#)

[Front panel LED power fault codes](#)

## Server UID LED

The UID LED can be used to help an on-site technician quickly identify or locate a particular server when it is deployed in a dense rack with other equipment. It can also be used to identify if a remote management, firmware upgrade, or reboot sequence is in progress.

## Viewing the Server Health Summary

## Prerequisites

- An external monitor is connected.
- In the iLO web interface, the Show Server Health on External Monitor feature is enabled on the Access Settings page.

## About this task

If the server does not power on, use the UID button to display the iLO Server Health Summary screen on an external monitor. This function works when the server is powered on or off.

For more information, see the iLO troubleshooting guide on the [Hewlett Packard Enterprise website](#).

## Procedure

1. Press and release the UID button.



### CAUTION

Be sure to press and release the UID button. Pressing the UID button at any time for more than five seconds will initiate a graceful iLO reboot or a hardware iLO reboot. Data loss or NVRAM corruption might occur during a hardware iLO reboot.

The Server Health Summary screen displays on the external monitor.

2. Press the UID button again to close the Server Health Summary screen.

## Front panel LED power fault codes

The following table provides a list of power fault codes, and the subsystems that are affected. Not all power faults are used by all servers.

Subsystem	LED behavior
System board	1 flash
Processor	2 flashes
Memory	3 flashes
Riser board PCIe slots	4 flashes
FlexibleLOM	5 flashes
Storage controller	6 flashes
System board PCIe slots	7 flashes
Power backplane	8 flashes
Storage backplane	9 flashes
Power supply	10 flashes
PCIe expansion cards installed in riser board	11 flashes
Chassis	12 flashes
GPU card	13 flashes

## Component touchpoints

Certain components are color-coded. These colors represent the recommended touch areas for a removal process and indicate whether components require a system shutdown before removal.

The following diagrams are examples only.

## HPE hot-plug red

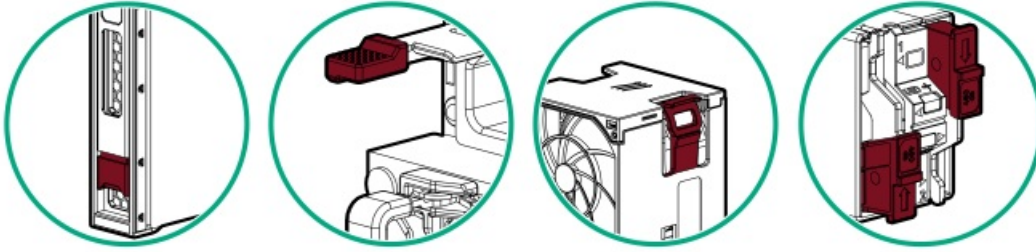

Hot-plug red indicates hot-pluggable components. These components can be removed and installed while the system is running, and doing so will not result in a system shutdown.

Component examples:

- Power supplies in a redundant power configuration
- Hot-plug fans
- Hot-plug drives
- M.2 SSDs in a hot-plug boot device

## HPE touchpoint blue

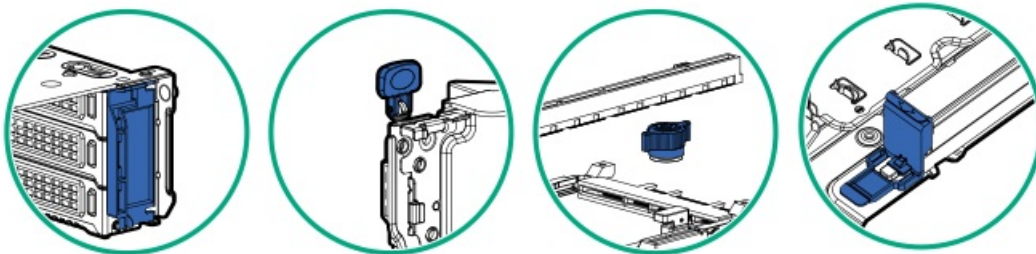

Touchpoint blue indicates cold-pluggable components. These components require a system shutdown. Failure to do so might result in system failure or data loss. Cold-pluggable components might also indicate touchpoints on non-electrical components.

Component examples:

- Storage devices
- Fan cages
- System boards
- Energy packs

## System board components

The grayed out components in the system board image are not for use in this server.

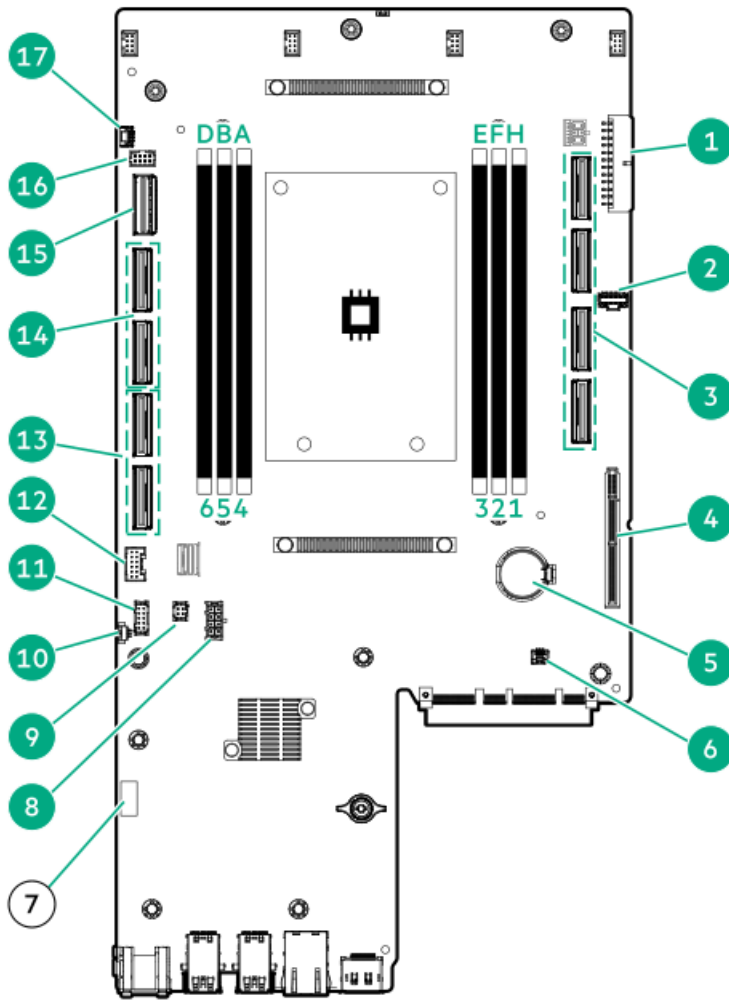

Item	Description
1	System board power connector
2	Sideband connector for the power supply
3	NVMe ports 3A–6A (from top to bottom)
4	Riser connector
5	System battery
6	Storage backup power connector
7	<u>System maintenance switch</u>
8	Drive backplane power connector
9	iLO service port connector
10	Remote temperature sensor connector
11	RJ45-serial port connector
12	Energy pack connector
13	MCIO ports 8A–7A (from top to bottom)
14	NVMe ports 2A–1A (from top to bottom) <sup>1</sup>
15	NS204i-u signal connector
16	M.2 SSD power connector <sup>2</sup>
17	Chassis intrusion detection switch connector

<sup>1</sup> NVMe port 1A supports NVMe and SATA.  
<sup>2</sup> This power connector is for the HPE NS204i-u Boot Device option.

## Subtopics

[System maintenance switch descriptions](#)

[DIMM label identification](#)

[DIMM slot numbering](#)

[Processor and socket components](#)

## System maintenance switch descriptions

Position	Default	Function
S1 <sup>1</sup>	Off	<ul style="list-style-type: none"><li>Off—iLO 6 security is enabled.</li><li>On—iLO 6 security is disabled.</li></ul>
S2	Off	Reserved
S3	Off	Reserved
S4	Off	Reserved
S5 <sup>1</sup>	Off	<ul style="list-style-type: none"><li>Off—Power-on password is enabled.</li><li>On—Power-on password is disabled.</li></ul>
S6 <sup>1, 2, 3</sup>	Off	<ul style="list-style-type: none"><li>Off—No function</li><li>On—Restore default manufacturing settings</li></ul>
S7	Off	Reserved
S8	Off	Reserved
S9	Off	Reserved
S10	Off	Reserved
S11	Off	Reserved
S12	Off	Reserved

<sup>1</sup> To access the redundant ROM, set S1, S5, and S6 to On.

<sup>2</sup> When the system maintenance switch position 6 is set to the On position, the system is prepared to restore all configuration settings to their manufacturing defaults.

<sup>3</sup> When the system maintenance switch position 6 is set to the On position and Secure Boot is enabled, some configurations cannot be restored. For more information, see [Configuring the server](#).

## DIMM label identification

To determine DIMM characteristics, see the label attached to the DIMM. The information in this section helps you to use the label to locate specific information about the DIMM.

For more information about product features, specifications, options, configurations, and compatibility, see the [HPE DDR5 SmartMemory QuickSpecs](#):

<https://www.hpe.com/docs/server-memory>

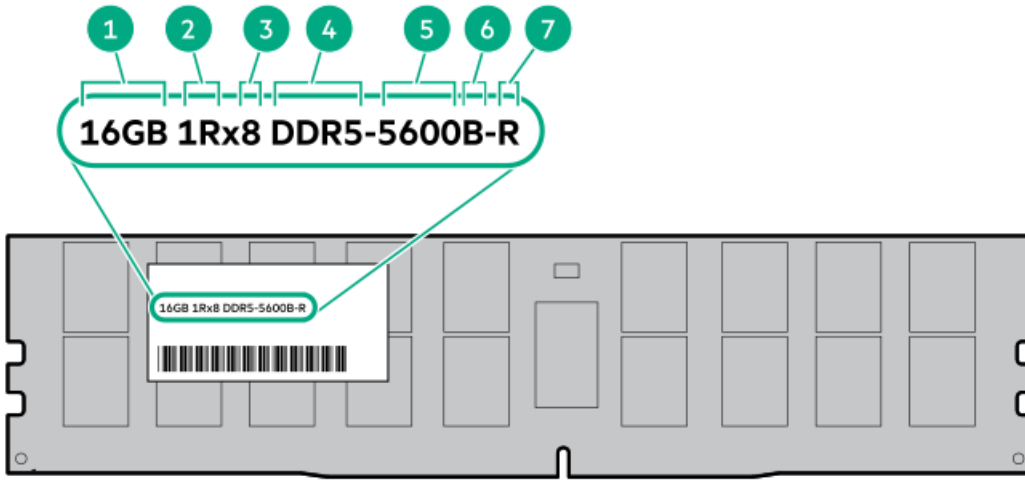

Item	Description	Example
1	Capacity *	16 GB 32 GB 64 GB 128 GB
2	Rank	1R—Single rank 2R—Dual rank
3	Data width on DRAM	x4—4-bit x8—8-bit
4	Memory generation	PC5—DDR5
5	Maximum memory speed *	4800 MT/s
6	CAS latency	B—42-42-42 B—50-42-42 (for 128 GB capacity)
7	DIMM type	R—RDIMM (registered)

\* The maximum memory speed and capacity is a function of the memory type, memory configuration, and processor model.

## DIMM slot numbering

The arrow points to the front of the server.

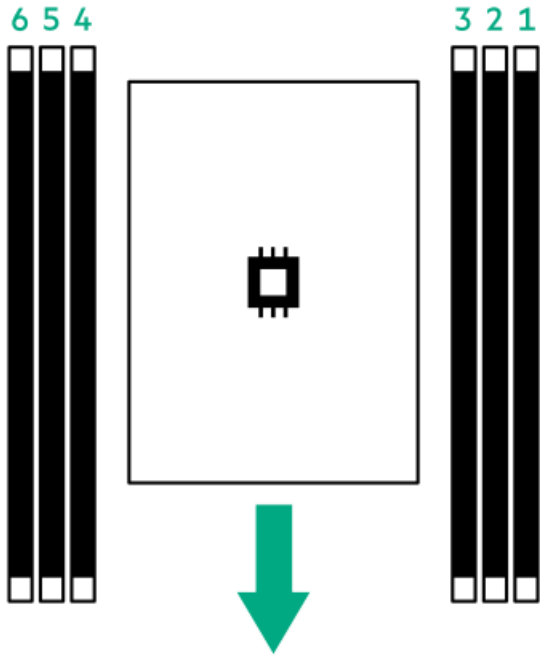

**Processor and socket components**

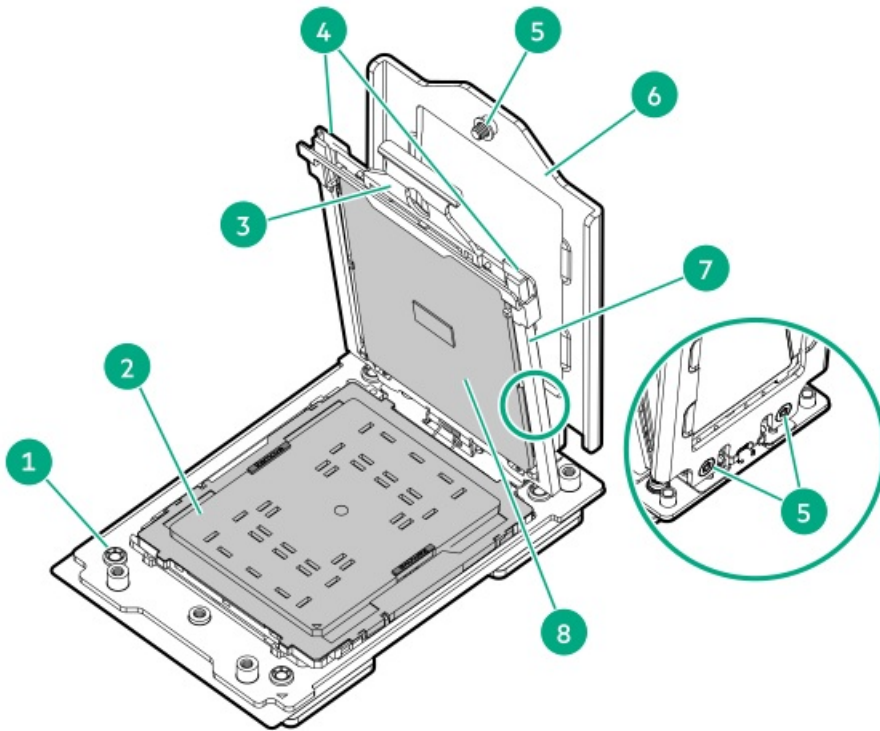

Item	Description
1	Processor socket
2	Pin field cover cap
3	Processor carrier
4	Rail frame lift tabs
5	Retention frame screws (T-20)
6	Retention frame
7	Rail frame
8	Processor

## Riser board components

This server supports two general types of PCIe risers:

- Standard riser—This riser is a board-only riser that is installed in a three-slot riser cage by default. This riser type is used:
  - As a standalone riser in a three-slot riser cage.
  - As the base riser in a three-slot riser cage.
- Cabled riser—This riser type has its signal cable soldered on the board itself. This riser type is combined with a standard, base riser and another cabled riser in a three-slot riser cage.

For clarity, the riser cage and the cables of the cabled risers are not always shown in the following images.

### Standard riser components

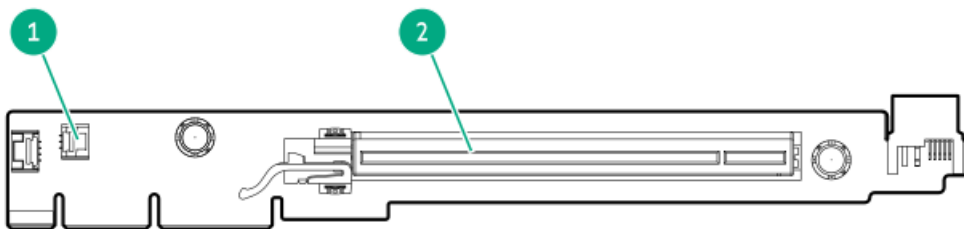

#### Item Description

- |   |   |
|---|---|
| 1 | Storage controller backup power connector |
| 2 | PCIe5 x16 (16, 8, 4, 1) slot              |

### Cabled riser components

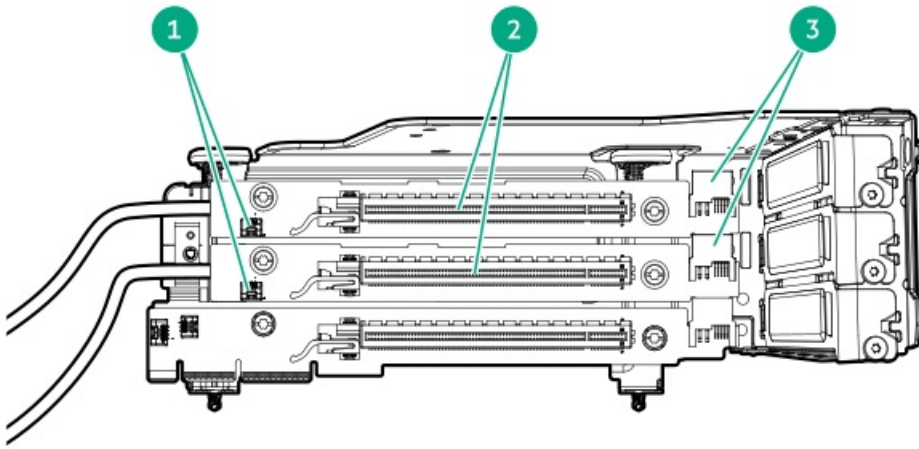

### Item Description

- |   |  |
|---|--|
| 1 | Storage controller backup power connectors |
| 2 | PCIe5 x16 (16, 8, 4, 1) slots              |
| 3 | Riser power connectors                     |

## Riser slot numbering

All riser slots are PCIe5 x16 (16, 8, 4, 1) and are rated for a maximum power draw of 75 W each.

## Three-slot riser configuration with optional cabled stacking risers

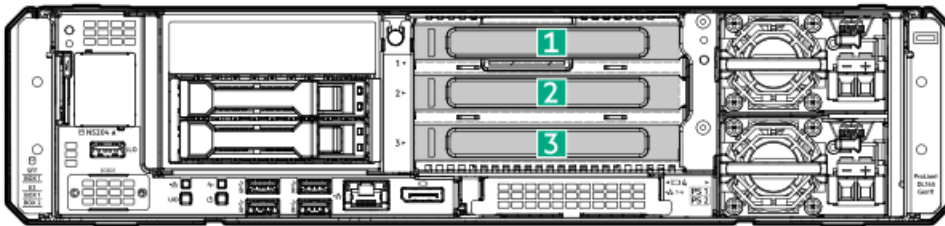

Slot number	Location	Description	Supported form factors
1	Three-slot riser cage	Stacking cabled riser (optional)	<ul style="list-style-type: none"> <li>Full-height, full-length *</li> <li>Full-height, half-length</li> <li>Half-height, half-length (low-profile)</li> </ul>
2		Stacking cabled riser (optional)	<ul style="list-style-type: none"> <li>Full-height, full-length *</li> <li>Full-height, half-length</li> <li>Half-height, half-length (low-profile)</li> </ul>
3		Base riser	<ul style="list-style-type: none"> <li>Full-height, half-length</li> <li>Half-height, half-length (low-profile)</li> </ul>

\* Some options are required to support full-size cards. For more information, see the product QuickSpecs on the Hewlett Packard Enterprise website (<https://www.hpe.com/info/quickspecs>).

### 3 single-width GPU configuration

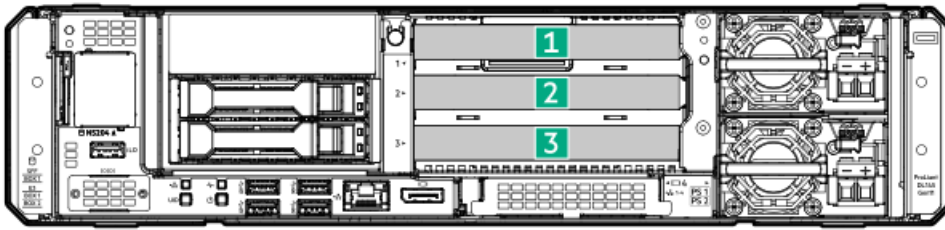

Slot number	Location	Description	Supported form factors
1	Three-slot riser cage	GPU	Single-width, half-height, half-length (low-profile)
2		GPU	
3		GPU	

### 2 single-width GPU configuration

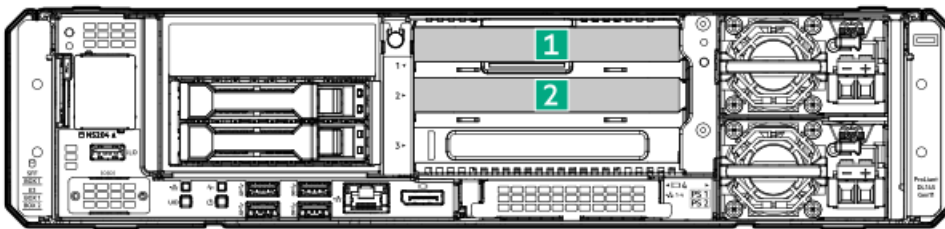

Slot number	Location	Description	Supported form factors
1	Three-slot riser cage	GPU	Single-width, half-height, half-length (low-profile)
2		GPU	
3		Type-p storage controller	

## HPE Basic Drive LED definitions

The HPE Basic drive carrier has the following LEDs:

- Amber/blue LED—Managed by the drive backplane in conjunction with the storage controller and is used to indicate drive status.
- Green LED—Managed by the drive itself and indicates the drive activity.

## SFF basic drive carrier

The SFF basic drive carrier supports hot-plug SAS, SATA, or U.3 NVMe drives .

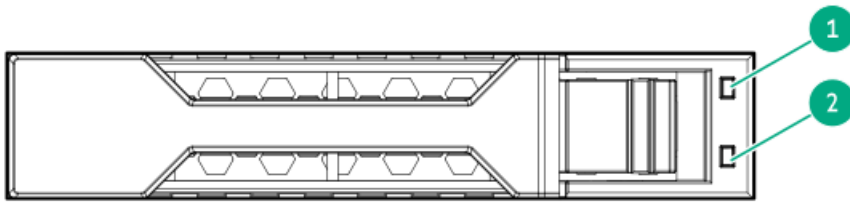

Item	LED	State	Definition
1	Fault/Locate	Solid amber	This drive has failed, is unsupported, or is invalid.
		Solid blue	The drive is operating normally and being identified by a management application.
		Flashing amber/blue (1 flash per second)	The drive has failed, or a predictive failure alert has been received for this drive. The drive has also been identified by a management application.
		Flashing amber (1 flash per second)	A predictive failure alert has been received for this drive. Replace the drive as soon as possible.
		Off	The drive is operating normally and not being identified by a management application.
2	Online/Activity	Solid green	The drive is online and has no activity.
		Flashing green (1 flash per second)	The drive is doing one of the following: <ul style="list-style-type: none"> <li>Rebuilding or performing a RAID</li> <li>Performing a stripe size migration</li> <li>Performing a capacity expansion</li> <li>Performing a logical drive extension</li> <li>Erasing</li> <li>Spare part activation</li> </ul>
		Flashing green (4 flashes per second)	The drive is operating normally and has activity.
		Off	The drive is not configured by a RAID controller or is a spare drive.

## EDSFF SSD LED definitions

The EDSFF drive carrier has two LEDs:

- Amber/blue LED—Managed by the drive backplane in conjunction with the storage controller and is used to indicate drive status.
- Green LED—Managed by the drive itself and indicates the drive activity.

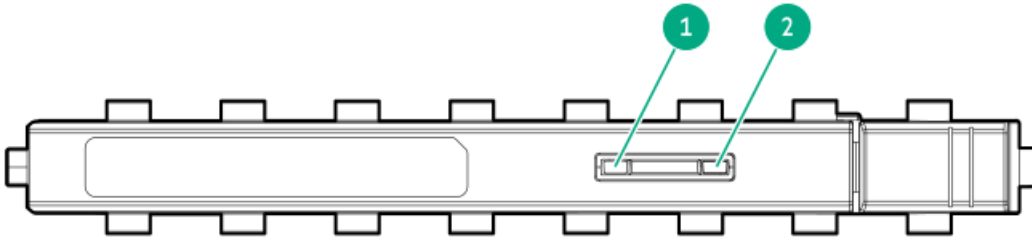

Item	LED	State	Definition
1	Fault/Locate	Solid amber	This drive has failed, is unsupported, or is invalid.
		Solid blue	The drive is operating normally and being identified by a management application.
		Flashing amber/blue (1 flash per second)	The drive has failed, or a predictive failure alert has been received for this drive. The drive has also been identified by a management application.
		Flashing amber (1 flash per second)	A predictive failure alert has been received for this drive. Replace the drive as soon as possible.
		Off	The drive is operating normally and not being identified by a management application.
2	Online/Activity	Solid green	The drive is online and has no activity.
		Flashing green (4 flashes per second)	The drive is operating normally and has activity.
		Off	No power present.

## Drive bay numbering



### CAUTION

When a server is purchased without any drive installed, some drive bays might be empty while other drive bays might be populated with drive blanks. To maintain proper system cooling, do not operate the server without a drive or a drive blank installed.

### Subtopics

[SFF drive bay numbering](#)

[E3.S drive bay numbering](#)

## SFF drive bay numbering

The following drive backplane options are supported in the 2 SFF drive configuration:

- 32G x4 U.3 NVMe / SAS / SATA UBM3 BC
- 24G x4 U.3 NVMe / SAS / SATA UBM6 BC

For more information on the drive backplane description, see [Drive backplane naming](#).

## 2 SFF drive bay numbering

Rack orientation

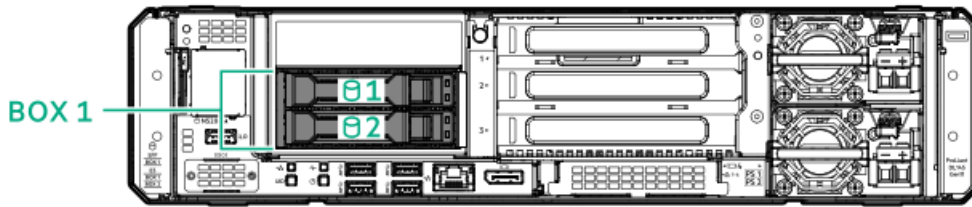

Wall mount orientation

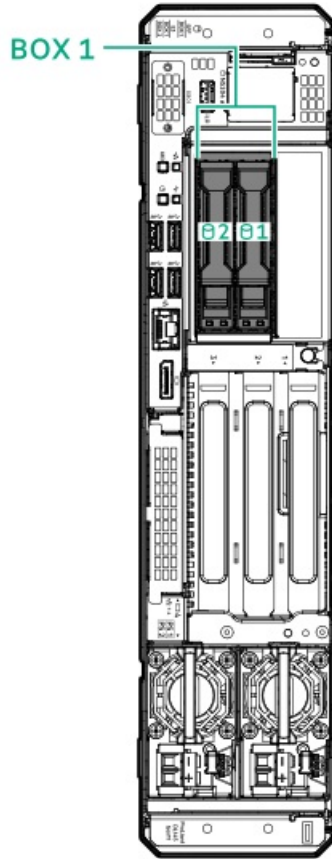

## E3.S drive bay numbering

The E3.S drive box supports 4 E3.S or 4 + 2 E3.S drives.

The following drive backplane and cable options are supported in 4 E3.S drive configuration:

- Direct attach options:
  - Backplane: 4 E3.S 32G x4 NVMe UBM10 EC1
  - 4 E3.S direct attached cable from Box 2 to system board
- Storage controller options:
  - Backplane: 4 E3.S 32G x4 NVMe UBM10 EC1
  - 4 E3.S SlimSAS cable from Box 2 to storage controller

The following drive backplane and cable options are supported in 4 + 2 E3.S drive configuration:

- Direct attach options:

- Backplane: 4 E3.S 32G x4 NVMe UBM10 EC1
- 2 E3.S direct attached cable from Box 1 to system board
- 4 E3.S direct attached cable from Box 2 to system board
- Storage controller options:
  - Backplane: 4 E3.S 32G x4 NVMe UBM10 EC1
  - 2 E3.S SlimSAS cable from Box 1 to storage controller
  - 4 E3.S SlimSAS cable from Box 2 to storage controller

For more information on the drive backplane description, see [Drive backplane naming](#).

## 4 E3.S drive bay numbering

Rack orientation

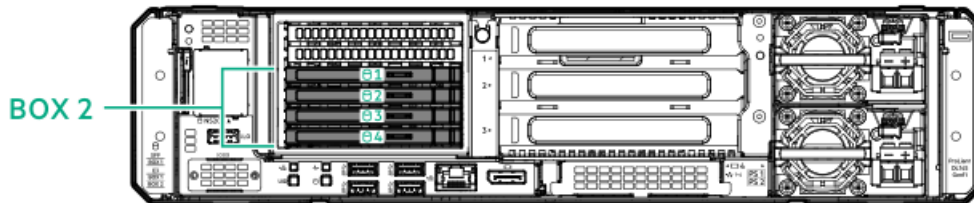

Wall mount orientation

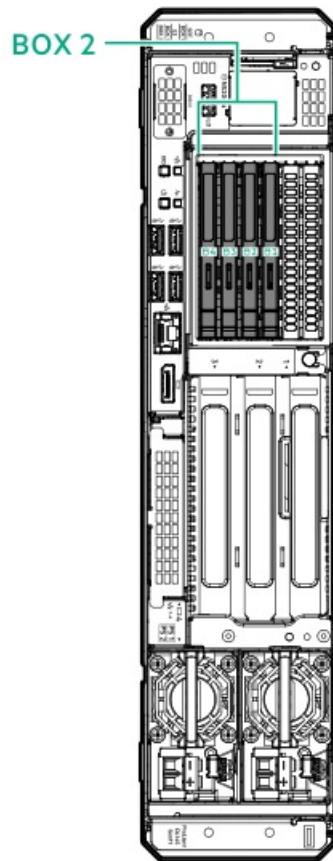

## 4 + 2 E3.S drive bay numbering

Rack orientation

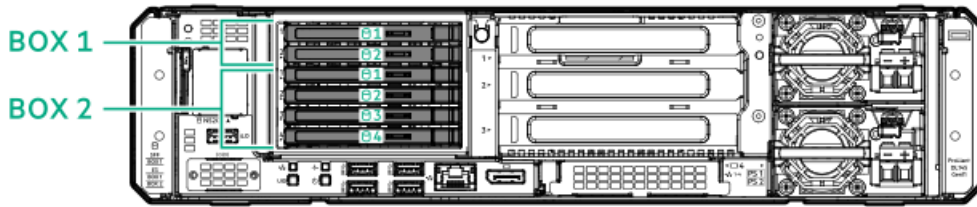

Wall mount orientation

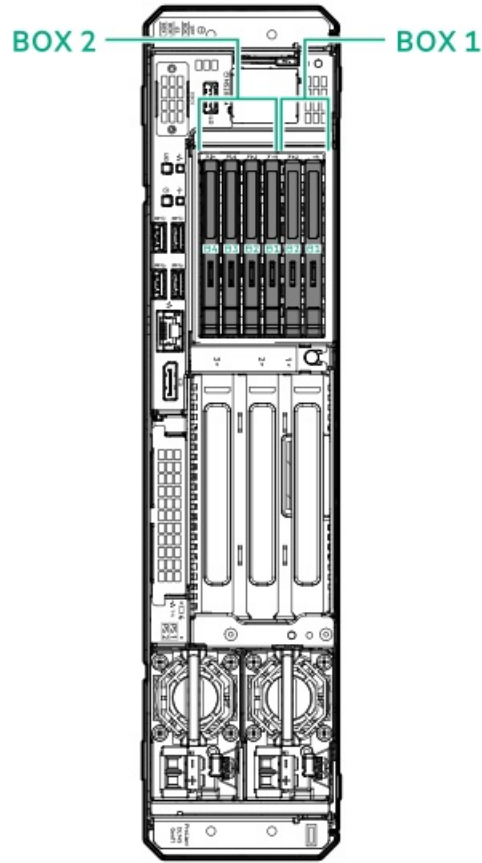

## Drive backplane naming

This topic explains the features represented in the drive backplane naming. This naming convention was adopted starting in the HPE Gen11 server release. Your server might not support all the features listed in this topic. For server-specific support information, see the server guides:

- Drive backplane support, see [Drive bay numbering](#).
- Drive backplane cabling, see [Storage cabling](#).



Item	Description	Values
1	Drive bay count	Number of drive bays supported by the backplane.
2	Drive form factor	LFF—Large Form Factor SFF—Small Form Factor E3S—Enterprise and Datacenter Standard Form Factor (EDSFF E3.S)
3	Maximum link rate per lane (GT/s)	12G 16G 24G 32G
4	Port link width and interface	x1 NVMe/SAS—U.3 NVMe, SAS, or SATA <sup>1</sup> x4 NVMe/SAS—U.3 NVMe, SAS, or SATA <sup>2</sup> x4 NVMe—U.2 NVMe <sup>3</sup> x4 NVMe—E3.S
5	Universal backplane manager (UBM) model	The UBM model defines the UBM firmware used by the backplane. Examples of UBM models: UBM2, UBM3, etc.
6	Drive carrier type	BC—Basic carrier (SFF) LP—Low-profile carrier (LFF) EC—E3.S carrier

<sup>1</sup> Tri-mode controller support for x1 U.3 NVMe, SAS, and SATA drives. System board connection supports SATA drives only (not available on Gen12).

<sup>2</sup> CPU direct attach or tri-mode controller support for x4 U.3 NVMe, x2 (via a splitter cable) U.3 NVMe, or x1 SAS and SATA drives.

<sup>3</sup> CPU direct attach or tri-mode controller support for x4 U.2 NVMe drives.

## GPU numbering

### 3 single-width GPUs

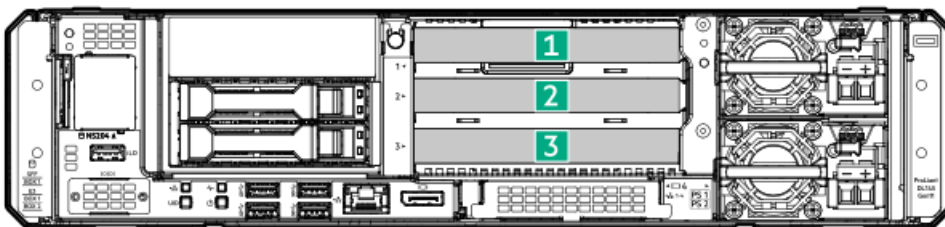

### 2 single-width GPUs

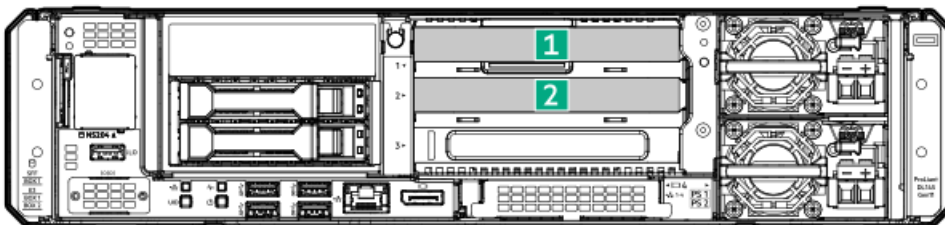

## Power distribution board (PDB) components

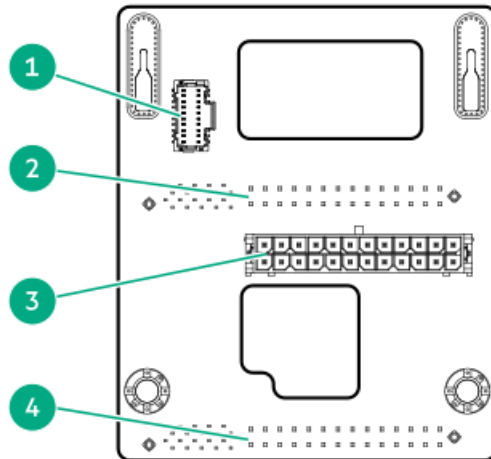

Item	Description	Connect to
1	Power supply sideband connector	System board: power supply sideband connector
2	Power supply connector 1 *	Power supply
3	System board power connector	System board: system board power connector
4	Power supply connector 2 *	Power supply

\* The connector is on the backside of the power distribution board.

## Fan numbering

To provide sufficient airflow to the system, the server is by default populated by four fans. The fans can either be standard, single-rotor fans (P72586-B21) or high performance, single-rotor fans (P72581-B21). Mixed fan configuration is not supported.

The arrow points to the front of the server.

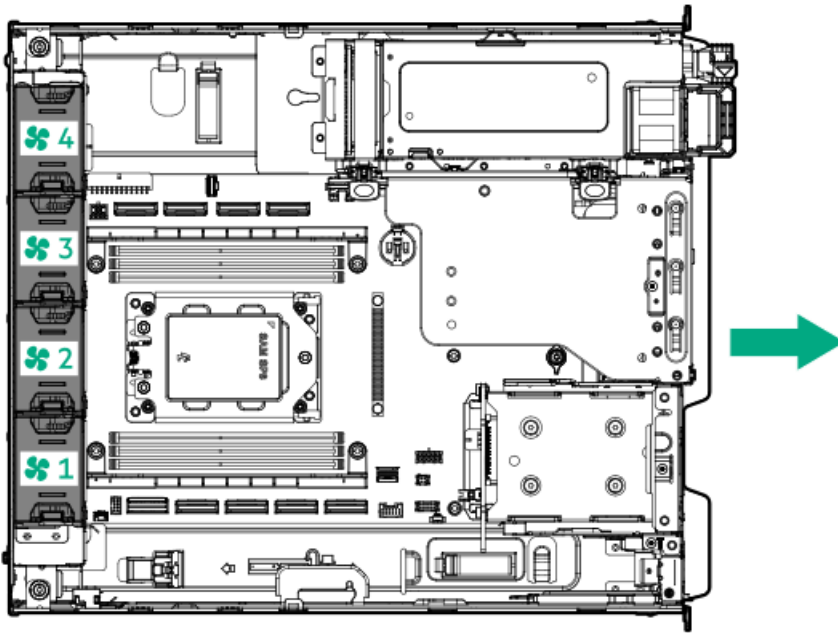

## Subtopics

### Fan and heatsink requirements

## Fan and heatsink requirements



### CAUTION

To maintain proper system cooling, install the correct fan and heatsink types required for specific hardware configurations.

## SFF/E3.S drive configuration

The information in this section is valid for up to the maximum 2 SFF, and 6 E3.S drive configurations. All fan bays need to be populated.

Drive configuration	Fan 1–4
2 SFF	Standard fan <sup>1</sup>
4 E3.S, or 6 E3.S	High performance fan <sup>2</sup>

- <sup>1</sup> Option kit: P72586-B21  
<sup>2</sup> Option kit: P72581-B21

## Trusted Platform Module 2.0

The Trusted Platform Module 2.0 (TPM) is a hardware-based system security feature that securely stores artifacts used to authenticate the platform. These artifacts can include passwords, certificates, and encryption keys.

The TPM 2.0 is embedded on the server system board.

The TPM 2.0 is supported with specific operating system support such as Microsoft Windows Server 2012 R2 and later. For more information about operating system support, see the product QuickSpecs on the Hewlett Packard Enterprise website (<https://www.hpe.com/info/quickspecs>). For more information about Microsoft Windows BitLocker Drive Encryption feature, see the

## Subtopics

[Trusted Platform Module 2.0 guidelines](#)

[BitLocker recovery key/password retention guidelines](#)

## Trusted Platform Module 2.0 guidelines



### CAUTION

- Always observe the TPM guidelines in this section. Failure to follow these guidelines can cause hardware damage or halt data access.
  - If you do not follow procedures for modifying the server and suspending or disabling the TPM in the OS, an OS that is using TPM might lock all data access. This includes updating system or option firmware, replacing hardware such as the system board and drives, and modifying TPM OS settings.
  - Changing the TPM mode after installing an OS might cause problems, including loss of data.
- Use the UEFI System Utilities to configure the TPM. From the System Utilities screen, select System Configuration > BIOS/Platform Configuration (RBSU) > Server Security > Trusted Platform Module options. For more information, see the UEFI user guide:  
<https://www.hpe.com/support/hpeuefisystemutilities-quicklinks>
  - When using the Microsoft Windows BitLocker Drive Encryption feature, always retain the recovery key or password. The recovery key or password is required to enter Recovery Mode after BitLocker detects a possible compromise of system integrity.
  - HPE is not liable for blocked data access caused by improper TPM use. For operating instructions, see the documentation for the encryption technology feature provided by the operating system.

## BitLocker recovery key/password retention guidelines

The recovery key/password is generated during BitLocker setup, and can be saved and printed after BitLocker is enabled. When using BitLocker, always retain the recovery key/password. The recovery key/password is required to enter Recovery Mode after BitLocker detects a possible compromise of system integrity.

To help ensure maximum security, observe the following guidelines when retaining the recovery key/password:

- Always store the recovery key/password in multiple locations.
- Always store copies of the recovery key/password away from the server.
- Do not save the recovery key/password on an encrypted drive.

## HPE NS204i-u Boot Device components

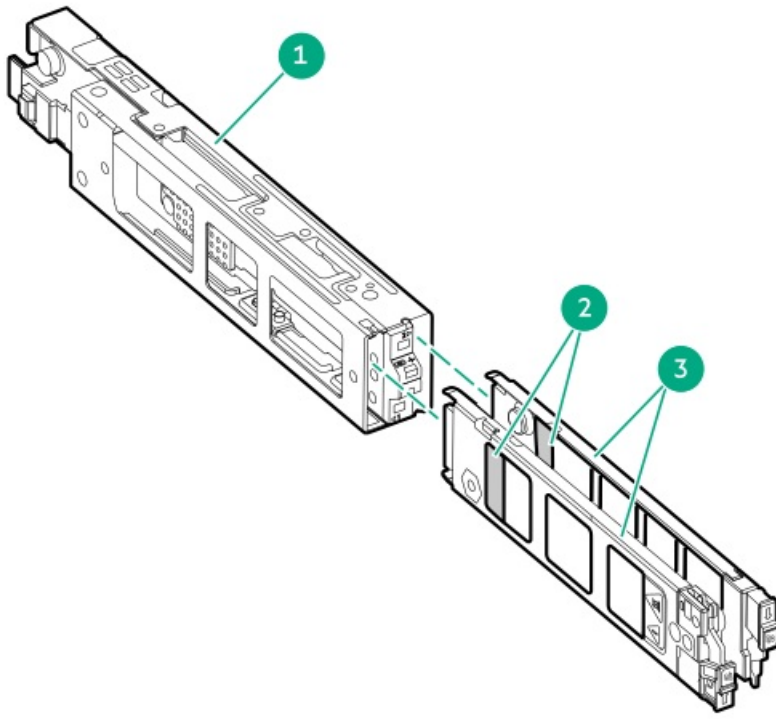

Item	Description
1	Boot device cage
2	M.2 slots
3	Boot device carriers

### HPE NS204i-u Boot Device LED definitions

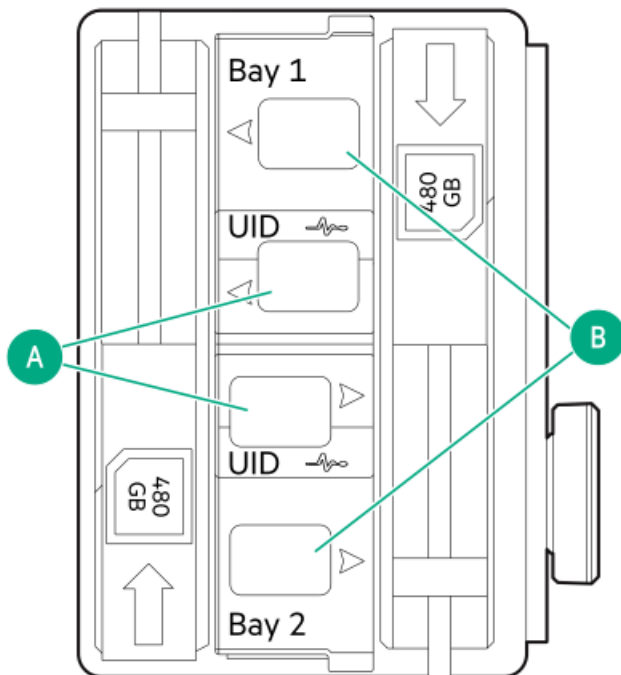

**NOTE**

The bay number can be found on the SSD carrier handle.

Item	LED	Status	Definition
A	Fault or Locate	Solid amber	Drive has failed, unsupported, or invalid.
		Solid blue	Drive is operating normally.
		Flashing amber or blue (one flash per second)	Drive has failed, or a predictive failure alert is received for the drive.
		Flashing amber (one flash per second)	Drive predictive failure alert is received. Replace the drive as soon as possible.
		Off	Drive is operating normally and is not identified by any application.
B	Online/Activity	Solid green	Drive is online and has no activity.
		Flashing green (one flash per second)	Drive is doing one of the following: <ul style="list-style-type: none"> <li>Rebuilding or performing a RAID</li> <li>Erasing</li> </ul>
		Flashing green (4 flashes per second)	Drive is operating normally and has activity.
		Off	Drive is not configured by a RAID controller.

## Cabling

This chapter includes cabling guidelines and diagrams for internal component cabling.

### Subtopics

[Cabling guidelines](#)

[Cabling diagrams](#)

[Internal cabling management](#)

[Stacking riser cabling](#)

[Storage cabling](#)

[HPE NS204i-u Boot Device cabling](#)

[iLO service port cabling](#)

[RJ45-serial port cabling](#)

[Ambient temperature sensor cabling](#)

[System power cabling](#)

[Chassis intrusion detection switch cabling](#)

## Cabling guidelines

Observe the following:

**NOTE**

The colors in the cabling diagrams are for illustration purposes only.

- For cable option kits, see the product QuickSpecs.
- For cable spare part numbers, see the Illustrated parts catalog in the maintenance and service guide.

- Some diagrams show alphabetical callouts such as A, B, C, etc. These callouts correspond to labels near the connectors on the cable.
- Some cables have more than one connector, such as a Y-cable, but not all connectors are used.
- Observe all guidelines when working with server cables.

## Before connecting cables

- Note the port labels on the PCA components. Not all these components are used by all servers:
  - System board ports
  - Drive and power supply backplane ports
  - Expansion board ports (controllers, retimers, adapters, expanders, risers, and similar boards)
- Note the label near each cable connector. This label indicates the destination port for the cable connector.
- Some data cables are prebent. Do not unbend or manipulate the cables.
- To prevent mechanical damage or depositing oil that is present on your hands, and other contamination, do not touch the ends of the connectors.

## When connecting cables

- Before connecting a cable to a port, lay the cable in place to verify the length of the cable.
- Use the internal cable management features to properly route and secure the cables.
- When routing cables, be sure that the cables are not in a position where they can be pinched or crimped.
- Avoid tight bend radii to prevent damaging the internal wires of a power cord or a server cable. Never bend power cords and server cables tight enough to cause a crease in the sheathing.
- Make sure that the excess length of cables is properly secured to avoid excess bends, interference issues, and airflow restriction.
- To prevent component damage and potential signal interference, make sure that all cables are in their appropriate routing position before installing a new component and before closing up the server after hardware installation/maintenance.

## When disconnecting cables

- Grip the body of the cable connector. Do not pull on the cable itself because this action can damage the internal wires of the cable or the pins on the port.
- If a cable does not disconnect easily, check for any release latch that must be pressed to disconnect the cable.

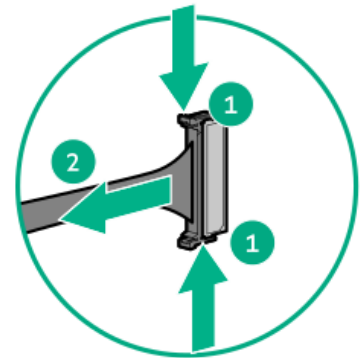
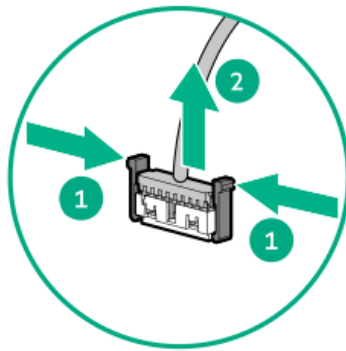
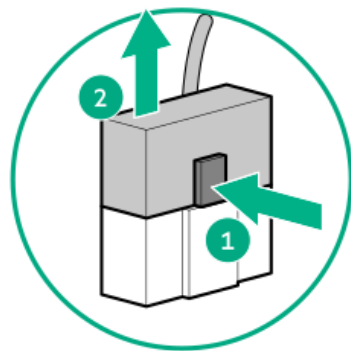
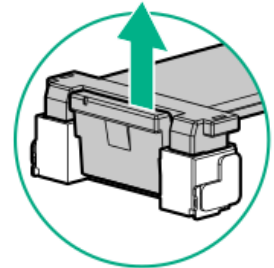
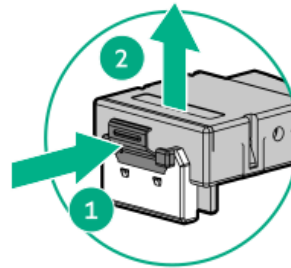
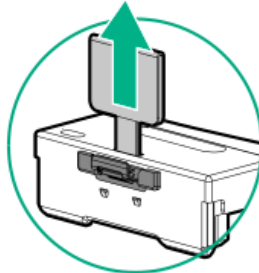
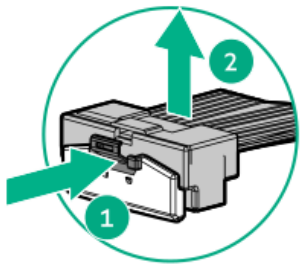
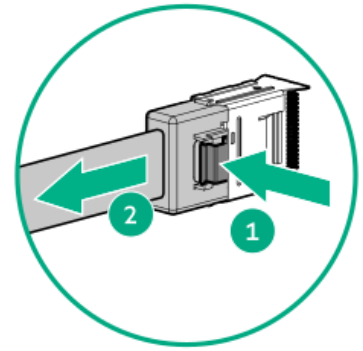
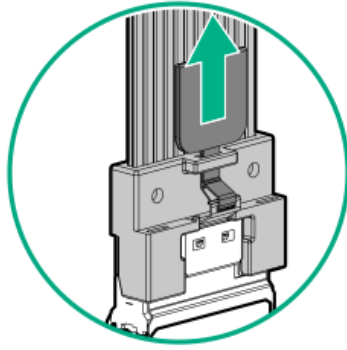
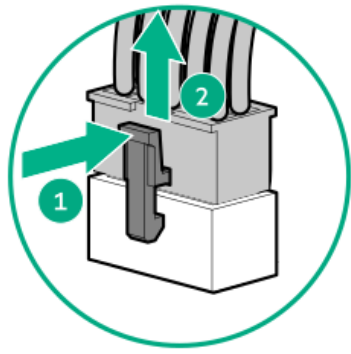

- Remove cables that are no longer being used. Retaining them inside the server can restrict airflow. If you intend to use the removed cables later, label and store them for future use.

## Cabling diagrams

Observe the following:

- Before cabling components, see the [Cabling guidelines](#).
- Use the cable part number or search feature to find your diagram.

Component cabling	Cable part number
<b>Stacking riser cabling</b>	—
PCIe Slot 1 stacking cabled riser	<a href="#">P51472-001</a>
PCIe Slot 2 stacking cabled riser	<a href="#">P50365-001</a>
<b>Storage Cabling</b>	—
2 SFF drive: Onboard SATA cable	<a href="#">P57307-001</a>
2 SFF drive: Onboard NVMe cable	<a href="#">P57311-001</a>
2 SFF drive controller cable: Type-p controller in the three-slot riser cage	<a href="#">P63696-001</a>
4 E3.S NVMe drive direct attach cable	<a href="#">P59100-001</a>
4 E3.S drive controller cable: Type-o controller in slot 21	<a href="#">P72526-001</a>
4 E3.S drive controller cable: Type-p controller in the three-slot riser cage	<a href="#">P51556-001</a>
2 E3.S Box 1 direct attach cable	<a href="#">P70286-001</a>
2 E3.S Box 1 drive controller cable: Type-p controller in the three-slot riser cage	<a href="#">P72524-001</a>
4 + 2 E3.S drive controller cable: Type-p controller in the three-slot riser cage	<a href="#">P72525-001</a>
4 + 2 E3.S drive power cable	<a href="#">P70282-001</a>
2 SFF drive power cable	<a href="#">P70281-001</a>
<b>Energy pack cabling</b>	—
Energy pack	<a href="#">P01366-B21</a>
<b>HPE NS204i-u Boot Device cabling</b>	—
HPE NS204i-u Boot Device power cable	<a href="#">P54088-001</a>
HPE NS204i-u Boot Device signal cable	<a href="#">P54087-001</a>
<b>Miscellaneous component cabling</b>	—
Power supply sideband cable	<a href="#">P54888-001</a>
System board power cable	<a href="#">P70280-001</a>
iLO service port cable	<a href="#">P70284-001</a>
RJ45-serial port cable	<a href="#">P70285-001</a>
Ambient temperature sensor cable	<a href="#">P37227-001</a>
Chassis intrusion detection switch cable	<a href="#">P47751-001</a>

## Internal cabling management

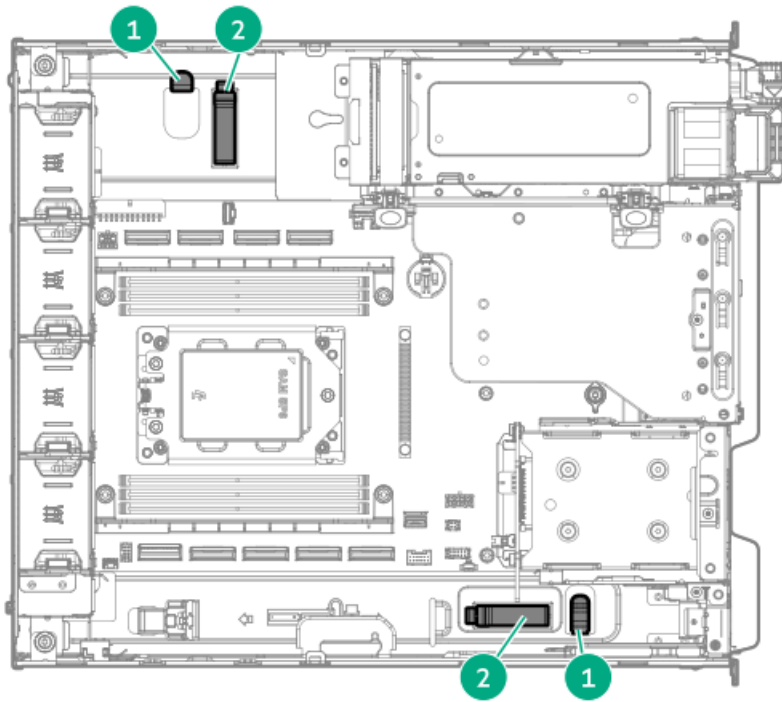

**Item Description**

- 1 Metal tab
- 2 Cable clamp

**Stacking riser cabling**

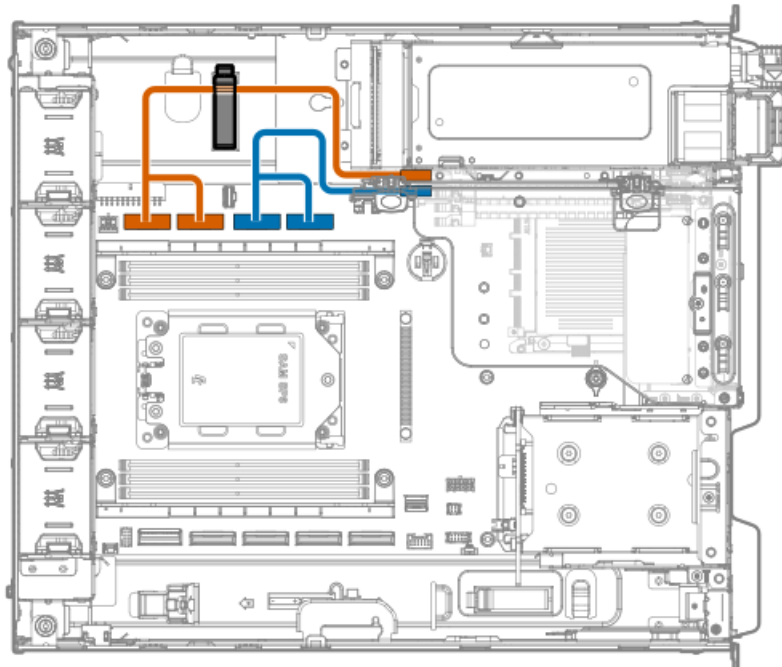

Riser part number	Color	From	To
P51472-001	Orange	PCIe Slot 1 stacking cabled riser	NVMe port 3A (SEC) and 4A (PRIM)
P50365-001	Blue	PCIe Slot 2 stacking cabled riser	NVMe port 5A (SEC) and 6A (PRIM)

## Storage cabling

### Subtopics

[Storage controller cabling](#)

[Drive power cabling](#)

[Energy pack cabling](#)

[Storage controller backup power cabling](#)

## Storage controller cabling

### Subtopics

[2 SFF SATA/NVMe drive controller cabling](#)

[4 E3.S NVMe drive controller cabling](#)

[4 + 2 E3.S NVMe drive controller cabling](#)

## 2 SFF SATA/NVMe drive controller cabling

### 2 SFF drive: Direct attached SATA/NVMe cabling

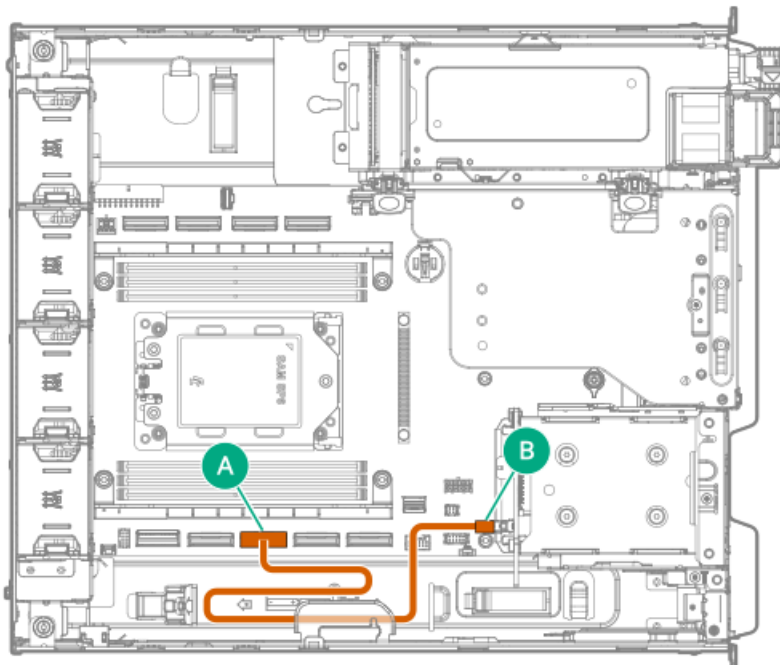

Cable part number	Cable color	From	To
SATA: P57307-001	Orange	Box 1 port 1	NVMe/SATA port 1A
NVMe: P57311-001	Orange	Box 1 port 1	NVMe/SATA port 1A

## 2 SFF drive controller cabling: Type-p storage controller in the three-slot riser cage

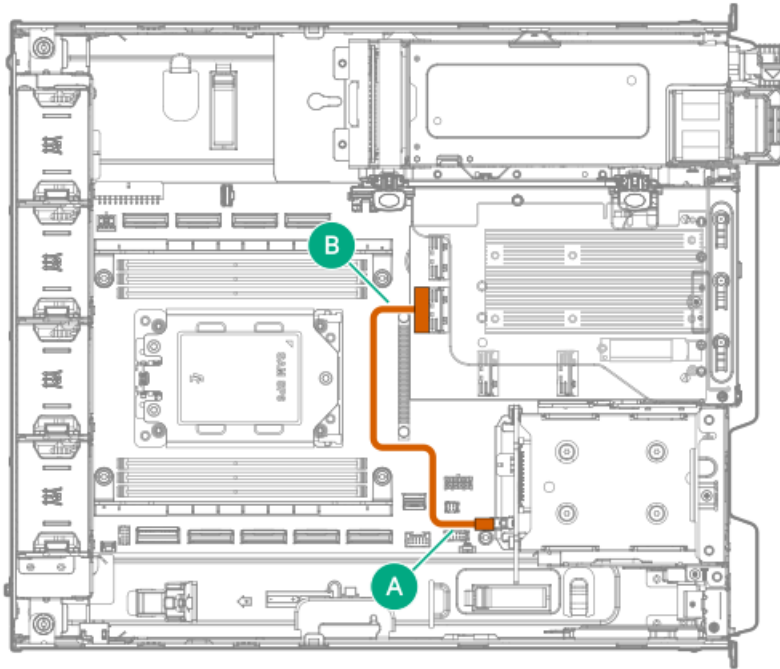

Cable part number	Cable color	From	To
P63696-001	Orange	Box 1 port 1	Type-p storage controller port 1

## 4 E3.S NVMe drive controller cabling

### 4 E3.S drive: Direct attached NVMe cabling

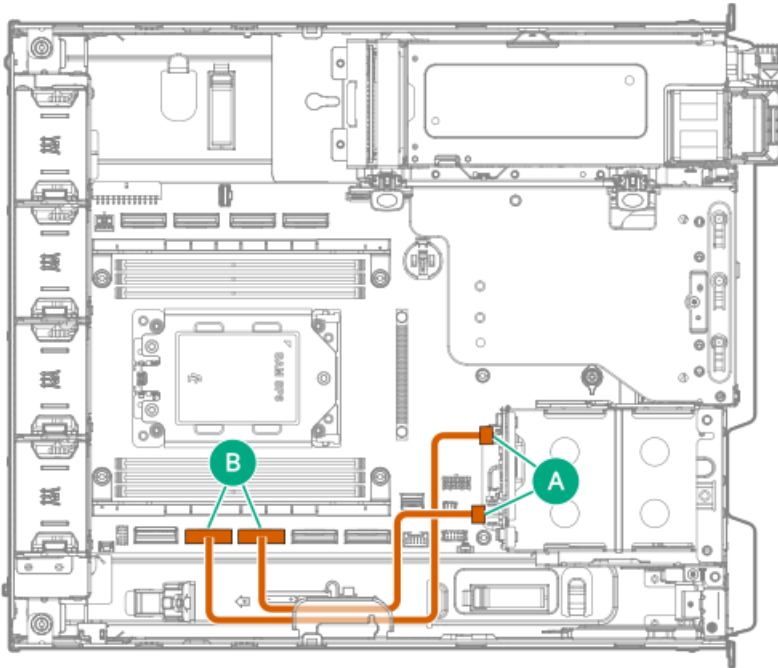

Cable part number	Cable color	From	To
P59100-001 <sup>1</sup>	Orange	Box 2 port 1	NVMe port 1A
		Box 2 port 2	NVMe port 2A

<sup>1</sup> Option kit: P71985-B21

#### 4 E3.S drive controller cabling: Type-o storage controller in slot 21

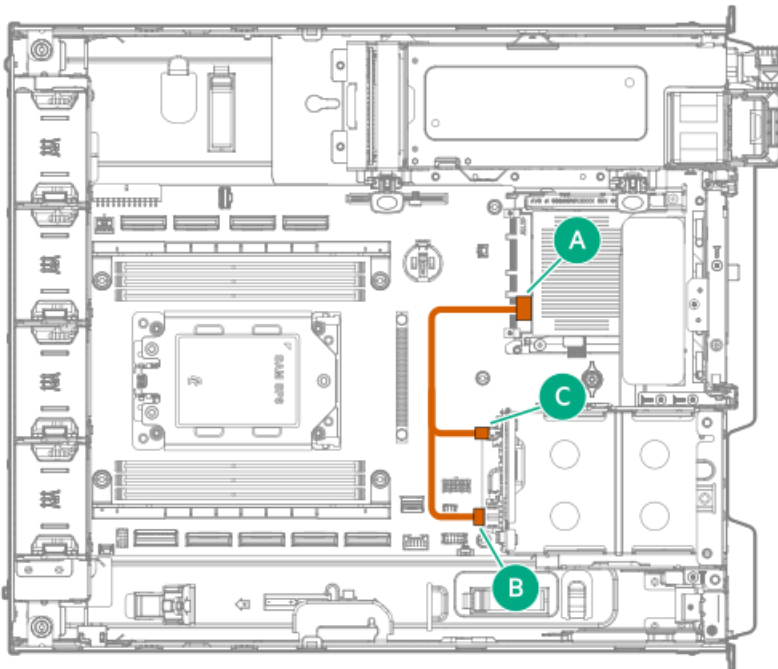

Cable part number	Cable color	From	To
P72526-001 <sup>1</sup>	Orange	Box 2 ports 1-2	Type-o storage controller port 1

1 Option kit: P72002-B21

#### 4 E3.S drive controller cabling: Type-p storage controller in the three-slot riser cage

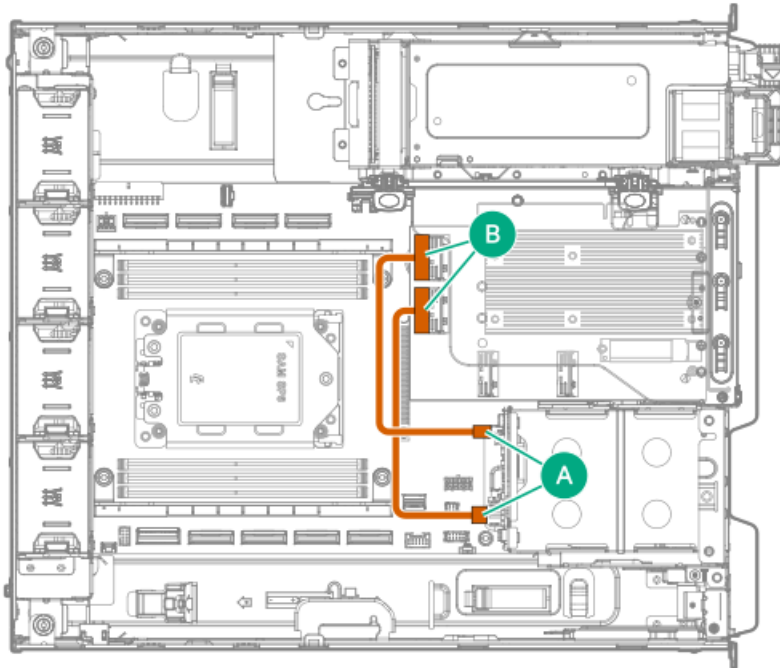

Cable part number	Cable color	From	To
P51556-001 <sup>1</sup>	Orange	Box 2 port 1	Type-p storage controller port 1
		Box 2 port 2	Type-p storage controller port 2

1 Option kit: P73003-B21

#### 4 + 2 E3.S NVMe drive controller cabling

The server supports 2 E3.S drives in Box 1 using the 6 E3.S enablement cable option (only for the 4 E3.S drive configuration).

#### 2 E3.S drive: Direct attached NVMe cabling

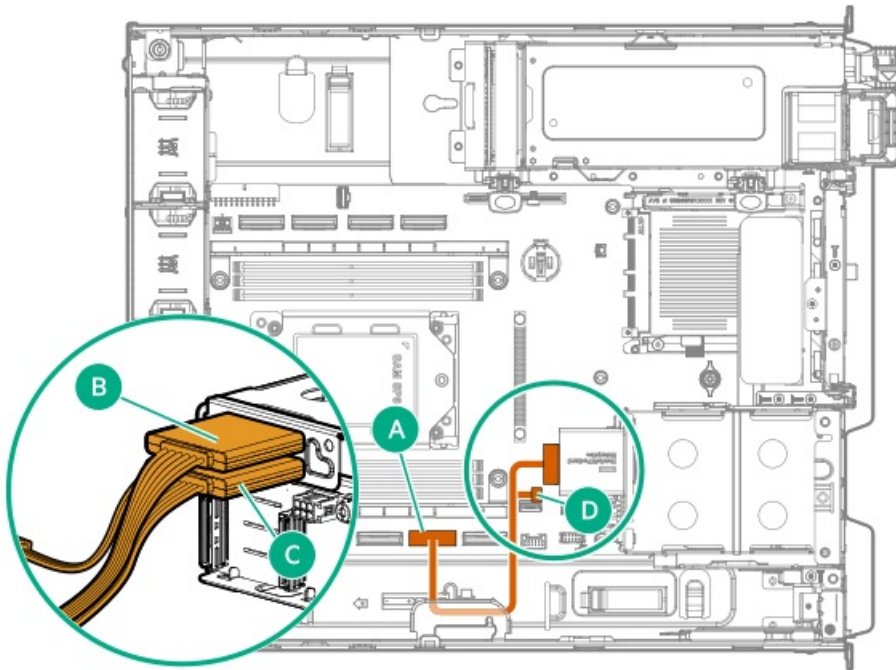

Cable part number	Cable color	From	To
P70286-001 <sup>1</sup>	Orange	Box 1	MCIO port 8A / 6 E3.S drive power Y cable

<sup>1</sup> Option kit: P71981-B21

#### 4 + 2 E3.S drive controller cabling: Type-p storage controller in the three-slot riser cage

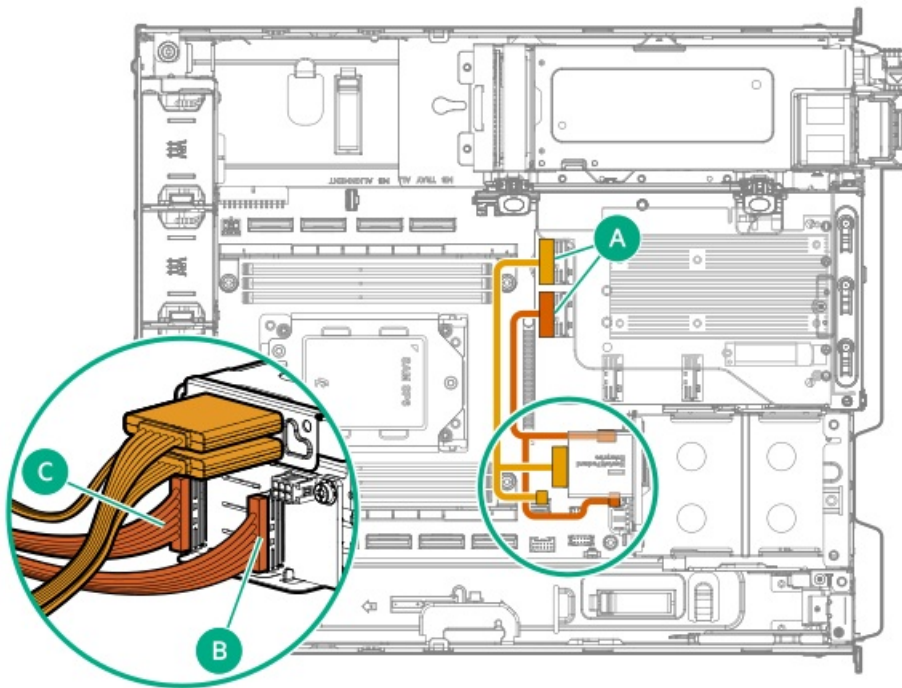

Cable part number	Cable color	From	To
P72525-001 <sup>1</sup>	Orange	Box 2 ports 1-2	Type-p storage controller port 1
P72524-001 <sup>1</sup>	Gold	Box 1	Type-p storage controller port 2 / 6 E3.S drive power Y cable

<sup>1</sup> Option kit: P72004-B21

## Drive power cabling

### 2 SFF drive power cable

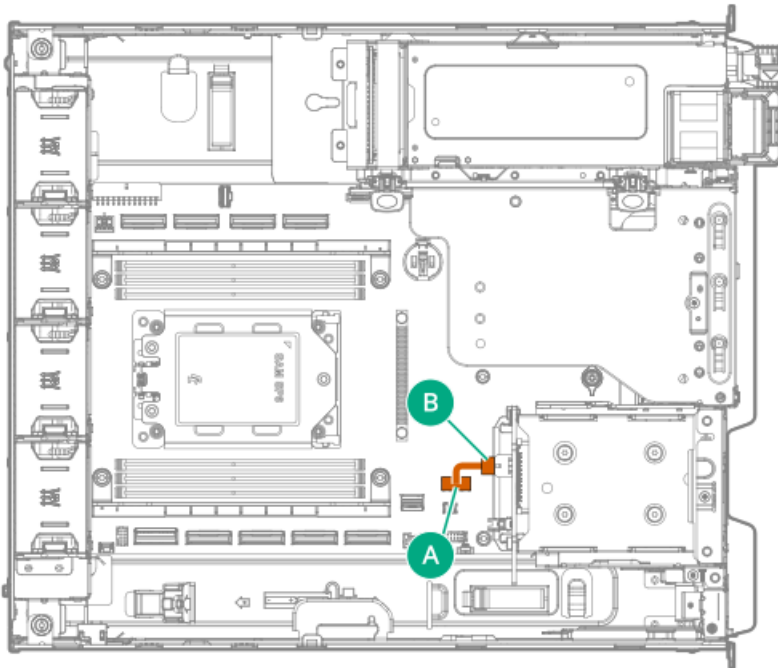

Cable part number	Cable color	From	To
P70281-001 <sup>1</sup>	Orange	Box 1	Backplane power connector (J9019)

<sup>1</sup> Option kit: P71977-B21

### 6 E3.S drive power Y cable

This cable is used in 4 or 4 + 2 E3.S drive configuration.

4 E3.S drive configuration:

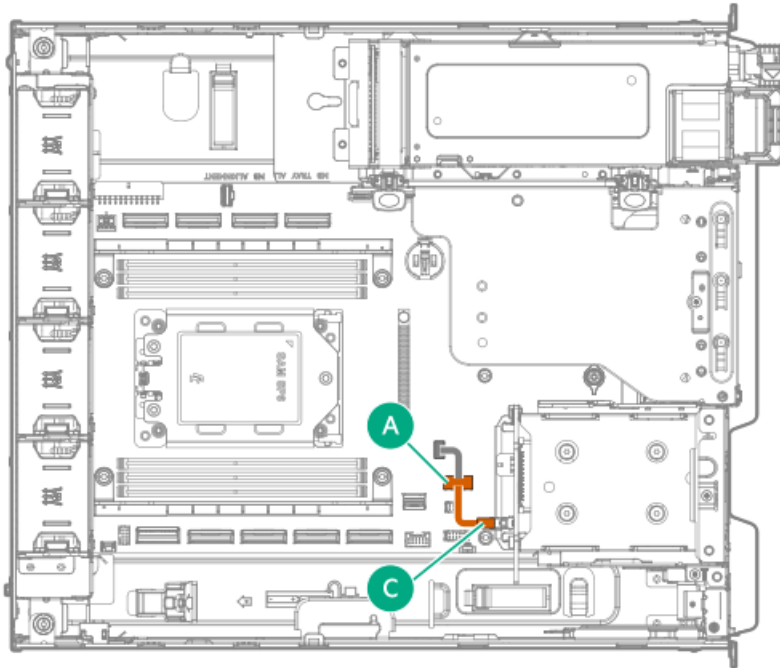

Cable part number	Cable color	From	To
P70282-001	Orange	Box 2	Backplane power connector (J9019) / Box 1

4 + 2 E3.S drive configuration:

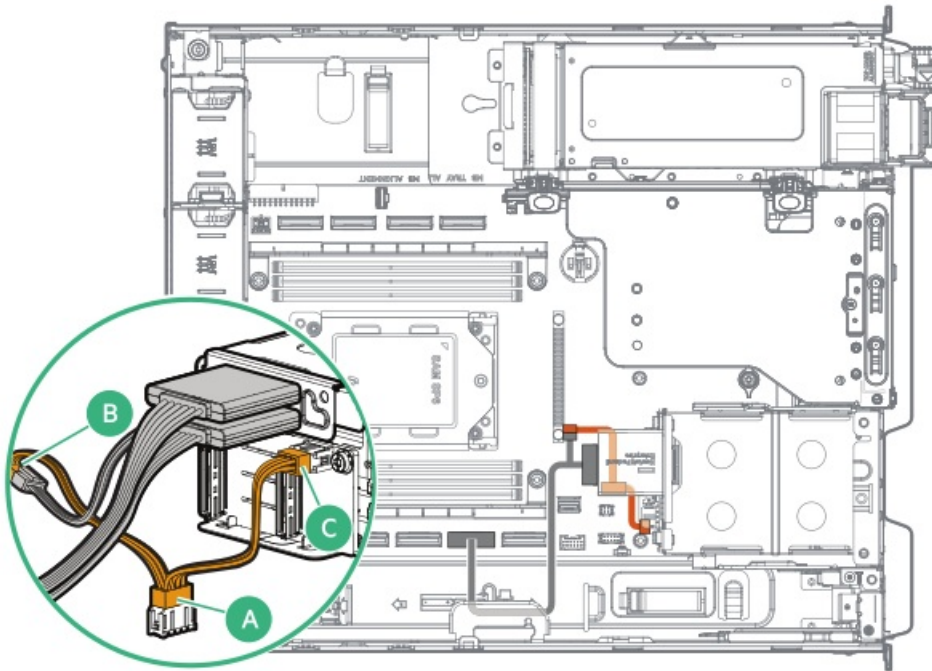

Cable part number	Cable color	From	To
P70282-001 <sup>1</sup>	Orange	Box 1—2	Backplane power connector (J9019)

<sup>1</sup> Option kit: P71985-B21

## Energy pack cabling

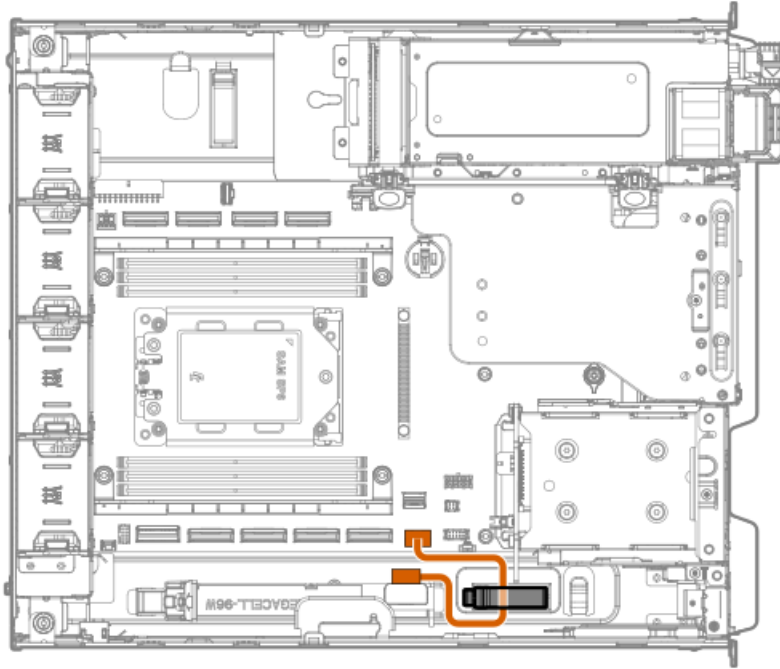

Cable color	From	To
Orange	Energy pack	Energy pack connector

Option kit: P01366-B21

## Storage controller backup power cabling

The exact route of the storage controller backup power cabling will depend on:

- The riser slot where the controller is installed
- The location of the storage controller backup power connector on the controller

Use the following diagrams for reference only.

### Type-p controller

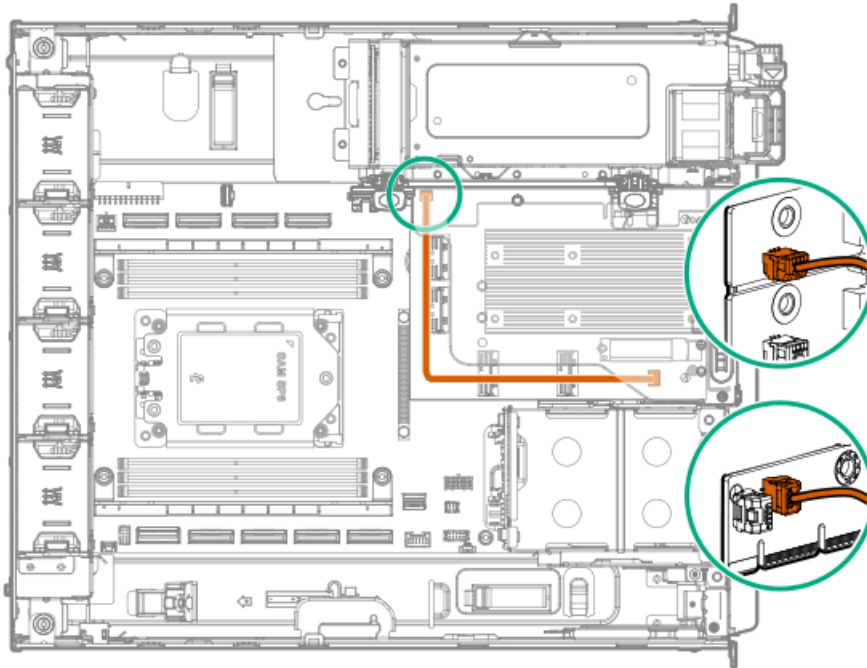

Color	From	To
Orange	Type-p controller	Storage controller backup power connector on the riser board

**Type-o controller**

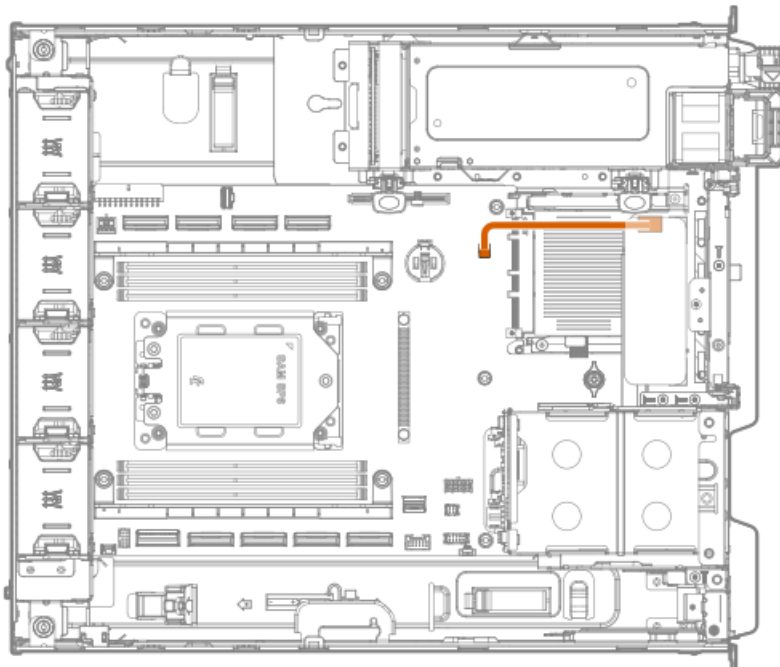

Color	From	To
Orange	Type-o controller in Slot 22	Storage backup power connector on the system board

## HPE NS204i-u Boot Device Cabling

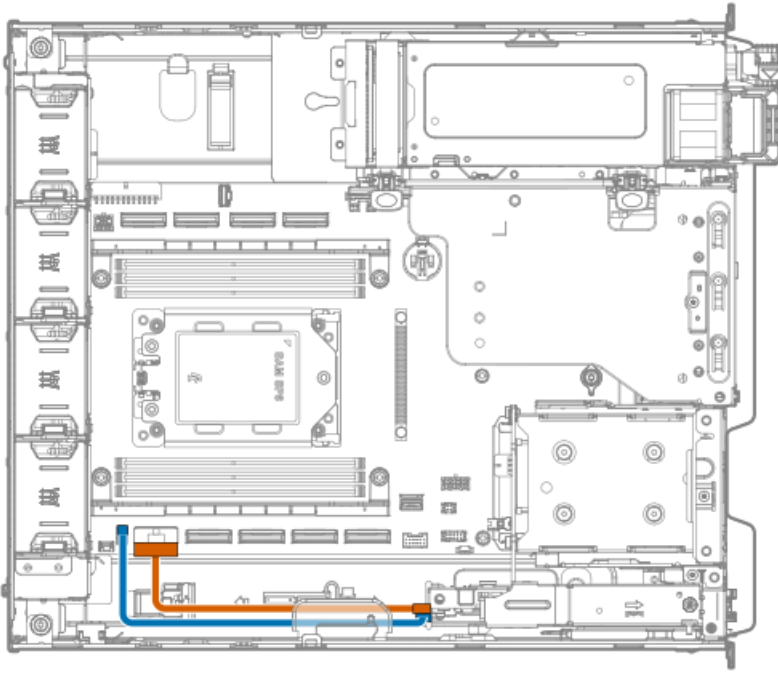

Cable part number	Color	From	To
P54088-001 <sup>1</sup>	Blue	HPE NS204i-u Boot Device	Boot device power connector
P54087-001 <sup>1</sup>	Orange		Boot device signal connector

<sup>1</sup> Option kit: P71992-B21

## iLO service port cabling

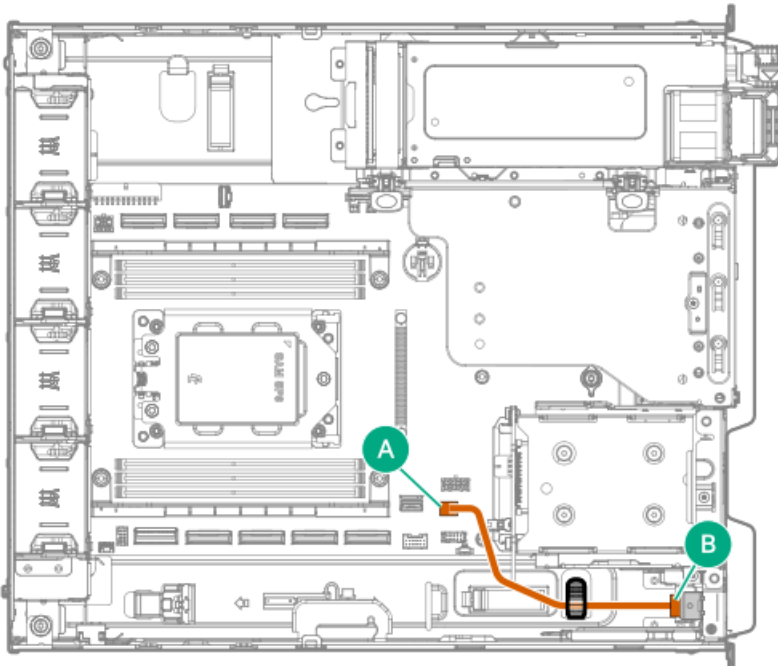

Cable part number	Color	From	To
P70284-001	Orange	iLO service port	iLO service port connector

## RJ45-serial port cabling

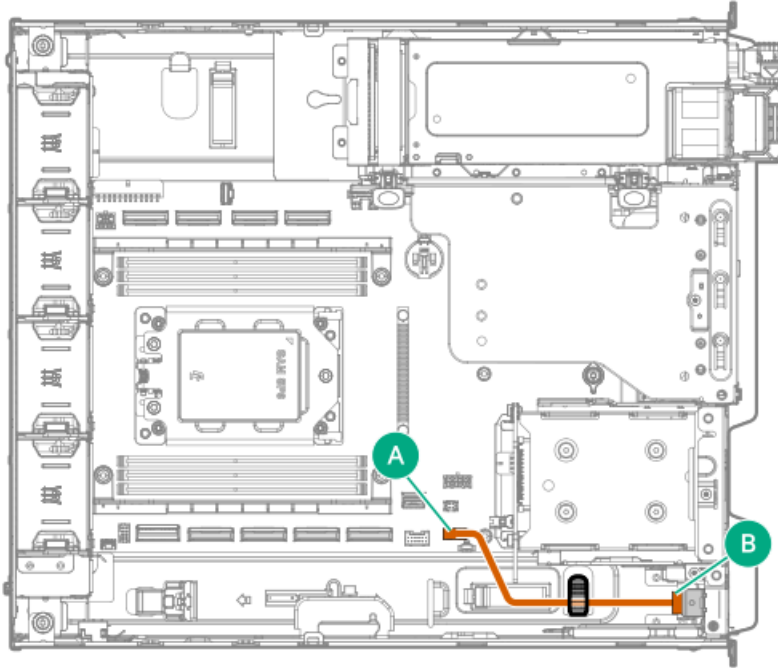

Cable part number	Color	From	To
P70285-001 <sup>1</sup>	Orange	RJ45-serial port	Serial port connector

<sup>1</sup> Option kit: P71998-B21

## Ambient temperature sensor cabling

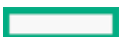

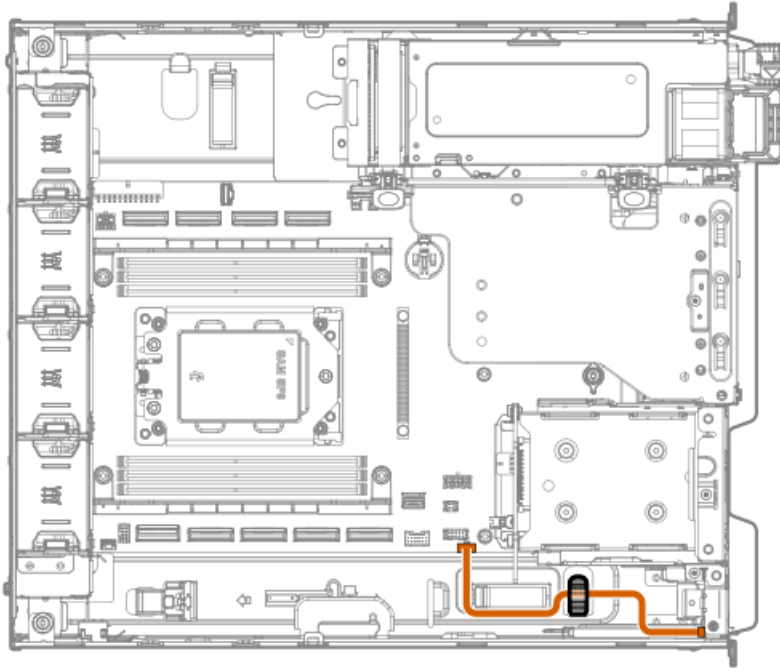

Cable part number	Color	From	To
P37227-001	Orange	Ambient temperature sensor	System board: Remote temperature sensor connector

## System power cabling

The power cables that connect the PDB to the system board are pre-installed in the server.

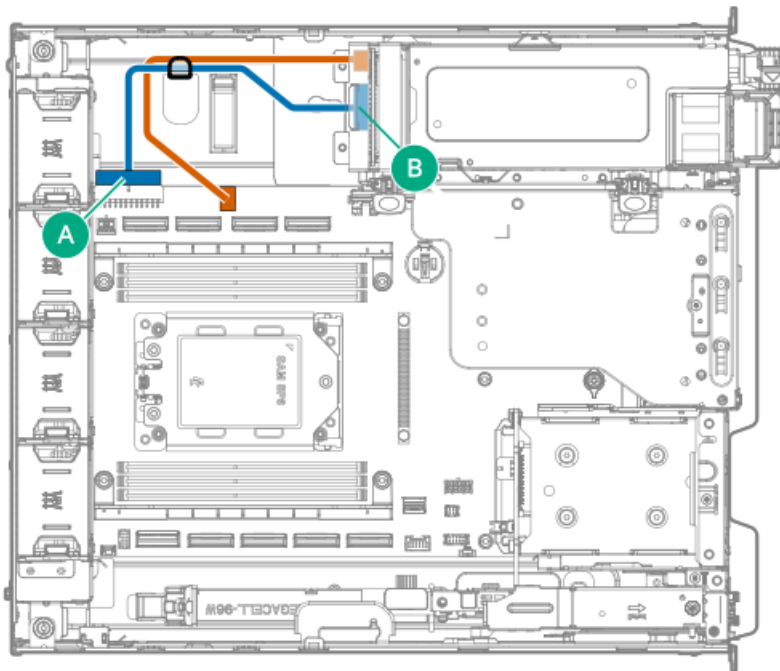

Cable part number	Cable color	From	To
P54888-001	Orange	PDB: Power supply sideband connector	System board: Power supply sideband connector
P70280-001	Blue	PDB: System board power connector	System board: System board power connector

## Chassis intrusion detection switch cabling

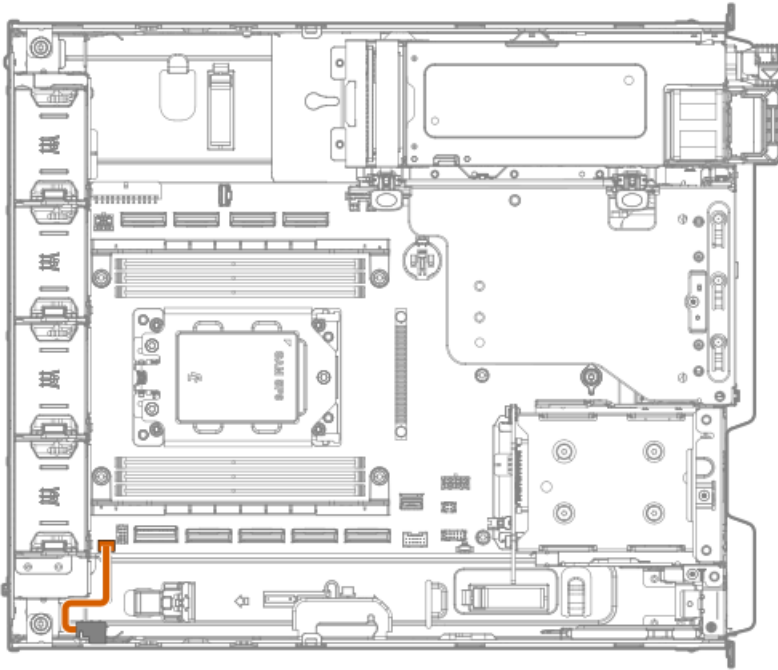

Cable part number	Color	From	To
P47751-001 <sup>1</sup>	Orange	Chassis intrusion detection switch	Chassis intrusion detection switch connector

<sup>1</sup> Option kit: P48922-B21

## Specifications

### Subtopics

[Environmental specifications](#)

[Mechanical specifications](#)

[Power supply specifications](#)

## Environmental specifications

Specifications	Value
<b>Temperature range*</b>	—
Operating	10°C to 35°C (50°F to 95°F)
Nonoperating	-30°C to 60°C (-22°F to 140°F)
<b>Relative humidity (noncondensing)</b>	—
Operating	8% to 90% 28°C (82.4°F) maximum wet bulb temperature, noncondensing
Nonoperating	5% to 95% 38.7°C (101.7°F) maximum wet bulb temperature, noncondensing
<b>Altitude</b>	—
Operating	3050 m (10,000 ft) This value may be limited by the type and number of options installed. Maximum allowable altitude change rate is 457 m/min (1,500 ft/min).
Nonoperating	9144 m (30,000 ft) Maximum allowable altitude change rate is 457 m/min (1,500 ft/min).

## Standard operating support

10°C to 35°C (50°F to 95°F) at sea level with an altitude derating of 1.0°C per every 305 m (1.8°F per every 1,000 ft) above sea level to a maximum of 3,050 m (10,000 ft), no direct sustained sunlight. Maximum rate of change is 20°C/hr (36°F/hr). The upper limit and rate of change may be limited by the type and number of options installed.

System performance during standard operating support might be reduced if operating above 30°C (86°F).

## Extended ambient operating support

For approved hardware configurations, the supported system inlet range is extended to be:

- 5°C to 10°C (41°F to 50°F) and 35°C to 40°C (95°F to 104°F) at sea level with an altitude derating of 1.0°C per every 175 m (1.8°F per every 574 ft) above 900 m (2,953 ft) to a maximum of 3050 m (10,000 ft).
- 40°C to 45°C (104°F to 113°F) at sea level with an altitude derating of 1.0°C per every 125 m (1.8°F per every 410 ft) above 900 m (2953 ft) to a maximum of 3,050 m (10,000 ft).
- 45°C to 55°C (113°F to 131°F) at sea level with an altitude derating of 1.0°C per every 80 m (1.8°F per every 262 ft) above sea level.

The approved hardware configurations for this system are listed in the [Extended Ambient Temperature Guidelines for Gen11 HPE ProLiant servers](#):

<https://www.hpe.com/support/ASHRAEGen11>

## Mechanical specifications

Specification	Value
<b>Dimensions</b>	—
Height	8.75 cm (3.44 in)
Depth	40.64 cm (16.00 in)
Width (without desktop installation hardware)	35.94 cm (14.15 in)
Width (with desktop installation hardware)	38.44 cm (15.13 in)
<b>Weight, approximate values</b>	—
Minimum, SFF (one drive, one DIMM, and one power supply installed)	9.83 kg (21.67 lb)
Maximum, SFF (two drives, six DIMMs, one boot device, and two power supplies installed, PCIe slots and OCP slot populated)	13.21 kg (29.12 lb)
Minimum, EDSFF (one drive, one DIMM, and one power supply installed)	9.76 kg (21.52 lb)
Maximum, EDSFF (six drives, six DIMMs, one boot device, and two power supplies installed, PCIe slots and OCP slot populated)	13.63 kg (30.05 lb)
Server and the desktop installation hardware (SFF, minimum)	11.81 kg (26.04 lb)
Server and the wall mount (SFF, minimum)	12.05 kg (26.57 lb)
Server and the rack mount (SFF, minimum)	11.38 kg (25.09 lb)
Server and the desktop installation hardware (SFF, maximum)	15.19 kg (33.49 lb)
Server and the wall mount (SFF, maximum)	15.43 kg (34.02 lb)
Server and the rack mount (SFF, maximum)	14.76 kg (32.54 lb)
Server and the desktop installation hardware (EDSFF, minimum)	11.74 kg (25.88 lb)
Server and the wall mount (EDSFF, minimum)	11.98 kg (26.41 lb)
Server and the rack mount (EDSFF, minimum)	11.31 kg (24.93 lb)
Server and the desktop installation hardware (EDSFF, maximum)	15.61 kg (34.41 lb)
Server and the wall mount (EDSFF, maximum)	15.85 kg (34.94 lb)
Server and the rack mount (EDSFF, maximum)	15.18 kg (33.47 lb)

## Power supply specifications

Depending on the installed options and the regional location where the server was purchased, the server can be configured with one of the following power supplies. For detailed power supply specifications, see the QuickSpecs on the [Hewlett Packard Enterprise website](#).

### Subtopics

[HPE 700 W Flex Slot Platinum Hot-plug Power Supply](#)

[HPE 700 W Flex Slot -48 VDC Hot-plug Low Halogen Power Supply](#)

[HPE 900 W–1000 W Flex Slot Titanium Hot-plug Power Supply](#)

## HPE 700 W Flex Slot Platinum Hot-plug Power Supply

Specification	Value		
Rated input voltage	100 VAC to 240 VAC 4.1 A to 8.3 A at 50 Hz to 60 Hz		
Input voltage range ( $V_{RMS}$ )	100 VAC to 240 VAC		
Nominal frequency range	50 Hz to 60 Hz		
Nominal input voltage	100 $V_{RMS}$	200 $V_{RMS}$	240 VDC
Maximum rated output	700 W	700 W	700 W
Maximum rated input	830 W	820 W	840 W
Maximum rated volt-ampere	780 VA	753 VA	840 VA



#### WARNING

To reduce the risk of electric shock or energy hazards:

- This equipment must be installed by trained service personnel.
- Connect the equipment to a reliably grounded secondary circuit source. A secondary circuit has no direct connection to a primary circuit and derives its power from a transformer, converter, or equivalent isolation device.

## HPE 700 W Flex Slot -48 VDC Hot-plug Low Halogen Power Supply

Specification	Value
<b>Input requirements</b>	—
Rated input voltage	-40 VDC to -72 VDC -48 VDC nominal input
Rated input current	20 A maximum at -40 VDC
Rated input power	760 W at -40 VDC input 754 W at -48 VDC input, nominal input 744 W at -72 VDC input
Rated input power (BTUs per hour)	2593 at -40 VDC input 2572 at -48 VDC input, nominal input 2537 at -72 VDC input
<b>Power supply output</b>	—
Rated steady-state power	700 W at -40 VDC to -72 VDC
Maximum peak power	700 W at -40 VDC to -72 VDC



### **WARNING**

To reduce the risk of electric shock or energy hazards:

- This equipment must be installed by trained service personnel.
- Connect the equipment to a reliably grounded secondary circuit source. A secondary circuit has no direct connection to a primary circuit and derives its power from a transformer, converter, or equivalent isolation device.



### **CAUTION**

This equipment is designed to permit the connection of the earthed conductor of the DC supply circuit to the earthing conductor at the equipment.

If this connection is made, all of the following must be met:

- This equipment must be connected directly to the DC supply system earthing electrode conductor or to a bonding jumper from an earthing terminal bar or bus to which the DC supply system earthing electrode conductor is connected.
- This equipment must be located in the same immediate area (such as adjacent cabinets) as any other equipment that has a connection between the earthed conductor of the same DC supply circuit and the earthing conductor, and also the point of earthing of the DC system. The DC system must be earthed elsewhere.
- The DC supply source is to be located within the same premises as the equipment.
- Switching or disconnecting devices must not be in the earthed circuit conductor between the DC source and the point of connection of the earthing electrode conductor.

## **HPE 900 W–1000 W Flex Slot Titanium Hot-plug Power Supply**

Specification	Value
<b>Input requirements</b>	—
Rated input voltage	100 VAC to 127 VAC 200 VAC to 240 VAC 240 VDC for China only
Rated input frequency	50 Hz to 60 Hz
Rated input current	10.2 A at 100 VAC 6.1 A at 200 VAC
Maximum rated input power	1010 W at 100 VAC 1090 W at 200 VAC
BTUs per hour	3446 at 100 VAC 3719 at 200 VAC
<b>Power supply output</b>	—
Rated steady-state power	900 W at 100 VAC to 127 VAC 1000 W at 200 VAC to 240 VAC input
Maximum peak power	900 W at 100 VAC to 127 VAC 1000 W at 200 VAC to 240 VAC

## Websites

### General websites

Single Point of Connectivity Knowledge (SPOCK) Storage compatibility matrix

<https://www.hpe.com/storage/spock>

Product white papers and analyst reports

<https://www.hpe.com/us/en/resource-library>

For additional websites, see [Support and other resources](#).

### Product websites

HPE ProLiant DL145 Gen11 Server user documents

<https://www.hpe.com/info/dl145gen11-docs>

## Support and other resources

- [Accessing Hewlett Packard Enterprise Support](#)
- [Accessing updates](#)
- [Remote support](#)
- [Warranty information](#)

- [Regulatory information](#)
- [Documentation feedback](#)

#### Subtopics

[Accessing Hewlett Packard Enterprise Support](#)

[Accessing updates](#)

[Remote support](#)

[Warranty information](#)

[Regulatory information](#)

[Documentation feedback](#)

## Accessing Hewlett Packard Enterprise Support

- For live assistance, go to the Contact Hewlett Packard Enterprise Worldwide website:

<https://www.hpe.com/info/assistance>

- To access documentation and support services, go to the Hewlett Packard Enterprise Support Center website:

<https://www.hpe.com/support/hpesc>

### Information to collect

- Technical support registration number (if applicable)
- Product name, model or version, and serial number
- Operating system name and version
- Firmware version
- Error messages
- Product-specific reports and logs
- Add-on products or components
- Third-party products or components

## Accessing updates

- Some software products provide a mechanism for accessing software updates through the product interface. Review your product documentation to identify the recommended software update method.
- To download product updates:

Hewlett Packard Enterprise Support Center

<https://www.hpe.com/support/hpesc>

My HPE Software Center

<https://www.hpe.com/software/hpesoftwarecenter>

- To subscribe to eNewsletters and alerts:

<https://www.hpe.com/support/e-updates>

- To view and update your entitlements, and to link your contracts and warranties with your profile, go to the [Hewlett Packard Enterprise Support Center More Information on Access to Support Materials](#) page:

<https://www.hpe.com/support/AccessToSupportMaterials>



#### IMPORTANT

Access to some updates might require product entitlement when accessed through the Hewlett Packard Enterprise Support Center. You must have an HPE Account set up with relevant entitlements.

## Remote support

Remote support is available with supported devices as part of your warranty or contractual support agreement. It provides intelligent event diagnosis, and automatic, secure submission of hardware event notifications to Hewlett Packard Enterprise, which initiates a fast and accurate resolution based on the service level of your product. Hewlett Packard Enterprise strongly recommends that you register your device for remote support.

If your product includes additional remote support details, use search to locate that information.

HPE Get Connected

<https://www.hpe.com/services/getconnected>

HPE Tech Care Service

<https://www.hpe.com/services/techcare>

HPE Complete Care Service

<https://www.hpe.com/services/completecure>

## Warranty information

To view the warranty information for your product, see the [warranty check tool](#).

## Regulatory information

To view the regulatory information for your product, view the [Safety and Compliance Information for Server, Storage, Power, Networking, and Rack Products](#), available at the Hewlett Packard Enterprise Support Center:

<https://www.hpe.com/support/Safety-Compliance-EnterpriseProducts>

## Additional regulatory information

Hewlett Packard Enterprise is committed to providing our customers with information about the chemical substances in our products as needed to comply with legal requirements such as REACH (Regulation EC No 1907/2006 of the European Parliament and the Council). A chemical information report for this product can be found at:

<https://www.hpe.com/info/reach>

For Hewlett Packard Enterprise product environmental and safety information and compliance data, including RoHS and REACH, see:

<https://www.hpe.com/info/ecodata>

For Hewlett Packard Enterprise environmental information, including company programs, product recycling, and energy efficiency, see:

## Documentation feedback

Hewlett Packard Enterprise is committed to providing documentation that meets your needs. To help us improve the documentation, use the Feedback button and icons (at the bottom of an opened document) on the Hewlett Packard Enterprise Support Center portal (<https://www.hpe.com/support/hpesc>) to send any errors, suggestions, or comments. This process captures all document information.

