

# ClickShare C-5, C-10

Model C 3010S



Installation manual

**Barco NV**

Beneluxpark 21, 8500 Kortrijk, Belgium  
[www.barco.com/en/support](http://www.barco.com/en/support)  
[www.barco.com](http://www.barco.com)

**Registered office: Barco NV**

President Kennedypark 35, 8500 Kortrijk, Belgium  
[www.barco.com/en/support](http://www.barco.com/en/support)  
[www.barco.com](http://www.barco.com)

## Copyright ©

All rights reserved. No part of this document may be copied, reproduced or translated. It shall not otherwise be recorded, transmitted or stored in a retrieval system without the prior written consent of Barco.

## Changes

Barco provides this manual 'as is' without warranty of any kind, either expressed or implied, including but not limited to the implied warranties or merchantability and fitness for a particular purpose. Barco may make improvements and/or changes to the product(s) and/or the program(s) described in this publication at any time without notice.

This publication could contain technical inaccuracies or typographical errors. Changes are periodically made to the information in this publication; these changes are incorporated in new editions of this publication.

The latest edition of Barco manuals can be downloaded from the Barco web site [www.barco.com](http://www.barco.com) or from the secured Barco web site <https://www.barco.com/en/signin>.

## Product Security Incident Response

As a global technology leader, Barco is committed to deliver secure solutions and services to our customers, while protecting Barco's intellectual property. When product security concerns are received, the product security incident response process will be triggered immediately. To address specific security concerns or to report security issues with Barco products, please inform us via contact details mentioned on <https://www.barco.com/psirt>. To protect our customers, Barco does not publically disclose or confirm security vulnerabilities until Barco has conducted an analysis of the product and issued fixes and/or mitigations.

## Patent protection

This product is covered by patents and/or pending patent applications. For more info: <https://www.barco.com/en/about-barco/legal/patents>.

## Trademarks

Brand and product names mentioned in this manual may be trademarks, registered trademarks or copyrights of their respective holders. All brand and product names mentioned in this manual serve as comments or examples and are not to be understood as advertising for the products or their manufacturers.





# Table of contents

<b>1</b>	<b>C-5, C-10 Introduction</b>	<b>7</b>
1.1	About the C-5, C-10	8
1.2	C-5, C-10 specifications	9
1.3	About the Base Unit	12
1.4	Mobile Device Support	14
<b>2</b>	<b>Getting started</b>	<b>15</b>
2.1	Environmental Condition Check	16
2.2	Security recommendations before starting	16
2.3	Basic Workflow	17
<b>3</b>	<b>C-5, C-10 Installation</b>	<b>19</b>
3.1	Installation methods for the Base Unit	20
3.2	Table mounting	20
3.3	Wall or ceiling mounting	20
3.4	Out-of-the-box use of the Base Unit	22
3.5	Network deployment requirements	23
3.6	Network connected setup	24
3.7	Dual network connected setup	24
3.8	Dedicated network setup	25
3.9	Video signal connections to the Base Unit	27
3.10	Touch screen connections to the Base Unit	27
3.11	LAN connection	27
3.12	Power connection	28
3.13	First startup of the Base Unit	28
3.14	Preferred way to start up	29
3.15	Start up without configuration	34
3.16	Registration to XMS Cloud	35
3.17	Activating calendar integration with XMS Cloud	37
<b>4</b>	<b>Preparing the Buttons</b>	<b>43</b>
4.1	Pairing the Button	44
4.2	ClickShare Extension Pack	44
4.3	ClickShare Extension Pack installer	45
4.4	ClickShare Windows Certified driver	46
4.5	ClickShare Desktop App	46

4.6	MSI installer of the ClickShare Desktop App.....	47
<b>5</b>	<b>C-5, C-10 Configurator .....</b>	<b>49</b>
5.1	Accessing the Configurator .....	51
5.2	ClickShare Configuration Wizard.....	54
5.3	On-Screen ID information .....	56
5.4	Personalisation, Wallpaper.....	58
5.5	Personalisation, Personalized wallpaper .....	59
5.6	Manage configuration files .....	61
5.7	Display & Audio setup .....	62
5.8	Peripherals .....	62
5.9	Wi-Fi settings.....	63
5.10	Wi-Fi settings, Access Point settings.....	64
5.11	Wi-Fi settings, Wireless Client.....	66
5.12	Wi-Fi settings, Wireless Client, EAP-TLS .....	67
5.13	Wi-Fi settings, Wireless Client, EAP-TTLS .....	69
5.14	Wi-Fi settings, Wireless Client, PEAP .....	70
5.15	Wi-Fi settings, Wireless Client, WPA2-PSK.....	71
5.16	LAN settings.....	72
5.17	LAN Settings, Wired Authentication .....	74
5.18	LAN Settings, EAP-TLS security mode .....	75
5.19	LAN Settings, EAP-TTLS security mode .....	77
5.20	Services, Mobile devices .....	78
5.21	Service, PresentSense .....	80
5.22	Service, ClickShare API, remote control via API.....	81
5.23	Services, SNMP.....	81
5.24	Security, security level.....	82
5.25	Security, passwords.....	84
5.26	Security, HTTP Encryption.....	84
5.27	Status information Base Unit.....	86
5.28	Date & Time setup, manually .....	87
5.29	Date & Time setup, time server.....	89
5.30	Energy savers .....	89
5.31	Buttons.....	90
5.32	Buttons, External access point, mode EAP-TLS.....	91
5.33	Buttons, External access point, mode EAP-TTLS.....	93
5.34	Buttons, External access point, mode PEAP .....	94
5.35	Buttons, External access point, mode WPA2-PSK .....	95
5.36	Blackboard.....	96
5.37	XMS Cloud Integration.....	96
5.38	Firmware Update.....	98
5.39	Support & Updates, Troubleshoot, log settings .....	99
5.40	Troubleshooting, Erase all settings.....	100
5.41	Reset to factory defaults .....	100
5.42	Troubleshoot, diagnostics .....	101
<b>6</b>	<b>Firmware updates .....</b>	<b>103</b>
6.1	Updating the C-5, C-10 firmware .....	104
<b>7</b>	<b>Troubleshooting .....</b>	<b>105</b>
7.1	Troubleshooting list.....	106
	<b>Index .....</b>	<b>109</b>

# C-5, C-10 Introduction

# 1

1.1	About the C-5, C-10 .....	8
1.2	C-5, C-10 specifications .....	9
1.3	About the Base Unit .....	12
1.4	Mobile Device Support .....	14

## About this document

This installation manual explains how to install your C-5, C-10 in a meeting room, It explains also how to make everything operational. It provides detailed information on how to configure your C-5, C-10.

## Available System documentation

Next to the installation manual, a user guide and a safety manual are available on Barco's website, [www.barco.com/clickshare](http://www.barco.com/clickshare).

A printed copy of the safety manual is included in the C-5, C-10 box at purchase.



Depending on the C-5, C-10 version, some graphics might be different to the ones used in this manual. This however does not have any effect on the functionality.

# 1.1 About the C-5, C-10

## C-5, C-10 sets

This ClickShare device is a wireless presentation system and your ticket to a collaborative meeting.

This device not only helps the presenter get the presentation on-screen in a second. The result is enhanced meeting efficiency and better decision-making.

The set is compatible with any laptop, desktop tablet or smartphone OS.

At the moment 6 different sets are available on the market. Each set is sold in its specific region and it can only be used in that specific region because of WiFi regulations.

## Components

### For C-10:

A standard C-10 set consists of a Base Unit and one Button. Depending on the location where you buy the product, the software of the Base Unit is different.

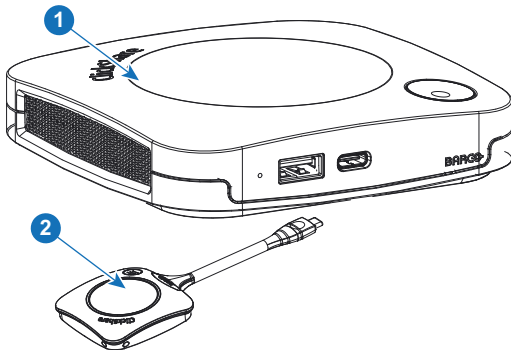

Image 1-1

- 1 Base Unit
- 2 Button

### For C-5:

A standard C-5 set consists of only a Base Unit. Depending on the location where you buy the product, the software of the Base Unit is different.

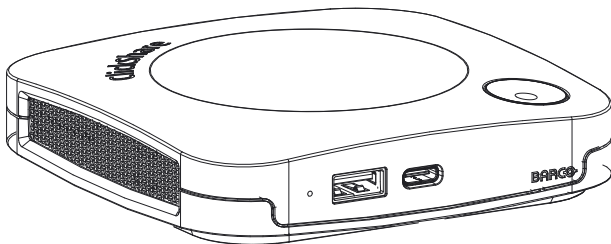

Image 1-2

## Accessories included

Depending on the country where you buy the product, the following regionalized accessories are also included in the box.

Products	Box content
C-10, R9861511xx <sup>1</sup>	<ul style="list-style-type: none"> <li>• R9861511</li> <li>• 1 x R9861600D1C<sup>2</sup></li> <li>• DC adapter with AC clips type A, C, G, I<sup>3</sup></li> <li>• Wall mount system</li> <li>• Printed safety manual</li> </ul>
C-5, R9861505xx <sup>1</sup>	<ul style="list-style-type: none"> <li>• R9861511</li> <li>• DC adapter with AC clips type A, C, G, I<sup>3</sup></li> <li>• Wall mount system</li> <li>• Printed safety manual</li> </ul>
R9861600D01C <sup>2, 4</sup>	1 x R9861600D1C <sup>2, 4</sup>

Contact your local sales representative for the correct regional variant to be used in your country.

## 1.2 C-5, C-10 specifications

### Base Unit C-10

<b>Dimensions (HxWxD)</b>	34 mm x 135 mm x 135 mm
<b>Power supply</b>	Standard 110/220 V AC plug or USB-C (only Gen2)
<b>Power consumption</b>	Operational: 5-10W, 24W Max
<b>Weight</b>	900 gr
<b>Operating system</b>	Windows 10 and higher macOS 11 (BigSur) and higher Android v9 and higher (ClickShare App)* iOS 12 and higher (ClickShare App)*
<b>Video outputs</b>	4K UHD (3840*2160) @ 30Hz. HDMI 1.4b or USB-C DisplayPort 1.2 (only Gen2)
<b>Audio output</b>	HDMI
<b>USB</b>	1 X USB-A, 1 X USB-C
<b>ClickShare Buttons</b>	1
<b>ClickShare App</b>	Desktop & Mobile
<b>Native protocols</b>	Airplay, Google Cast, Miracast*
<b>Maximum number of simultaneous connections (with Buttons and/or App)</b>	32
<b>Noise Level</b>	Max. 25dBA @ 0-30°C Max. 30dBA @ 30-40°C
<b>Authentication protocol</b>	WPA2-PSK in stand alone mode WPA2-PSK or IEEE 802.1X using the ClickShare Button in network integration mode

1. xx=EU, CN, NA, US, ZH, RW,  
2. For US, R9861600D1CUS  
3. Included AC clips can be different according to the region  
4. Not for C-5

<b>Wireless transmission protocol</b>	IEEE 802.11 a/g/n/ac and IEEE 802.15.1
<b>Reach</b>	Adjustable with signal strength modulation; max. 30m (100 ft) between ClickShare Button and ClickShare Base Unit Frequency band 2.4 GHZ and 5 GHZ
<b>Frequency band</b>	2.4 GHZ and 5 GHZ (DFS channels supported in select number of countries)
<b>Connections</b>	1x Ethernet LAN 1Gbit 1x USB-C 2.0 (front); 1x USB-A 2.0 (front) - only Gen2; 1x USB-C 3.0 (front); 1x USB-A 3.0 (front)
<b>Temperature range</b>	Operating: 0°C to +40°C (+32°F to +104°F) Max: 35°C (95°F) at 3000m Storage: -20°C to +60°C (-4°F to +140°F)
<b>Humidity</b>	Storage: 0 to 90% relative humidity, non-condensing Operation: 0 to 85% relative humidity, non-condensing
<b>Anti-theft system</b>	Kensington lock
<b>Certifications</b>	FCC/CE
<b>Touch screen support &amp; Interactivity</b>	Yes
<b>Room Dock (peripheral support)</b>	No
<b>Local view</b>	Yes
<b>Network connection</b>	LAN & WiFi
<b>Management and reporting</b>	Yes
<b>Warranty</b>	1 year standard. 5 years coverage via SmartCare
*	* depends on configuration, available in future firmware updates

### Base Unit C-5

<b>Dimensions (HxWxD)</b>	34 mm x 135 mm x 135 mm
<b>Power supply</b>	Standard 110/220 V AC plug or USB-C (only Gen2)
<b>Power consumption</b>	Operational: 5-10W, 24W Max
<b>Weight</b>	900 gr
<b>Operating system</b>	Windows 10 and higher macOS 11 (BigSur) and higher Android v9 and higher (ClickShare App)* iOS 12 and higher (ClickShare App)*
<b>Video outputs</b>	4K UHD (3840*2160) @ 30Hz. HDMI 1.4b or USB-C DisplayPort 1.2 (only Gen2)
<b>Audio output</b>	HDMI
<b>USB</b>	1 X USB-A, 1 X USB-C
<b>ClickShare Buttons</b>	0

<b>ClickShare App</b>	Desktop & Mobile
<b>Native protocols</b>	Airplay, Google Cast, Miracast
<b>Maximum number of simultaneous connections (with Buttons and/or App)</b>	32
<b>Noise Level</b>	Max. 25dBA @ 0-30°C Max. 30dBA @ 30-40°C
<b>Authentication protocol</b>	WPA2-PSK in stand alone mode WPA2-PSK or IEEE 802.1X using the ClickShare Button in network integration mode
<b>Wireless transmission protocol</b>	IEEE 802.11 a/g/n/ac and IEEE 802.15.1
<b>Reach</b>	Adjustable with signal strength modulation; max. 30m (100 ft) between ClickShare Button and ClickShare Base Unit Frequency band 2.4 GHZ and 5 GHz
<b>Frequency band</b>	2.4 GHZ and 5 GHz (DFS channels supported in select number of countries)
<b>Connections</b>	1x Ethernet LAN 1Gbi 1x USB-C 2.0 (front); 1x USB-A 2.0 (front) - only Gen2: 1x USB-C 3.0 (front); 1x USB-A 3.0 (front)
<b>Temperature range</b>	Operating: 0°C to +40°C (+32°F to +104°F) Max: 35°C (95°F) at 3000m Storage: -20°C to +60°C (-4°F to +140°F)
<b>Humidity</b>	Storage: 0 to 90% relative humidity, non-condensing Operation: 0 to 85% relative humidity, non-condensing
<b>Anti-theft system</b>	Kensington lock
<b>Certifications</b>	FCC/CE
<b>Touch screen support &amp; Interactivity</b>	/
<b>Room Dock (peripheral support)</b>	No
<b>Local view</b>	Local view of the room display only
<b>Network connection</b>	LAN & WiFi
<b>Management and reporting</b>	Yes
<b>Warranty</b>	1 year standard. 5 years coverage via SmartCare
*	* depends on configuration, available in future firmware updates

## Button

<b>Weight</b>	60 gr - 0.132 lb
<b>Frequency band</b>	2.4 GHZ and 5 GHz
<b>Wireless transmission protocol</b>	IEEE 802.11 a/b/g/n/ac

<b>Authentication protocol</b>	WPA2-PSK in stand alone mode WPA2-PSK or IEEE 802.1X in network integration mode
<b>Connectors</b>	USB-C type
<b>Dimensions (HxWxD)</b>	14.6 mm x 59.3 mm x 161.39 mm / 0.57" x 2.354" x 6.354"
<b>Power consumption</b>	Powered over USB 5V DC 350mA Typical 500mA Maximum

## 1.3 About the Base Unit

### Base Unit functionality

The Base Unit receives the wireless input and controls the content of the meeting room display.

The Base Unit can be put on the meeting room table or mounted on a wall or ceiling. Check the installation guide for instructions on how to install the Base Unit.

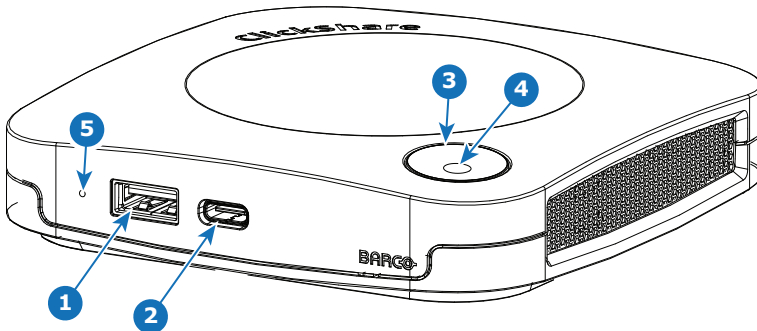

Image 1-3

- |   |                           |
|---|---------------------------|
| 1 | USB Type-A port (USB 2.0) |
| 2 | USB Type-C port (USB 2.0) |
| 3 | Status LED ring           |
| 4 | Standby button            |
| 5 | Hardware reset button     |

### USB ports

The USB Type-C™ is used to pair the available Buttons. The USB Type-C™ and USB Type-A can be used to update the Base Unit firmware when not done via XMS.

When plugging in the Button into the Base Unit, the Button is paired to the Base Unit. The Base Unit checks whether the software and firmware of the Button is up to date. If not, the Base Unit updates the software and/or firmware.

The use of a converter is sometimes necessary to connect to one of these ports.

### Status LED ring

The color of the LED ring around the power button of the Base Unit give information on the status of the system.



LEDs behavior	Explanation
static red	<ul style="list-style-type: none"> <li>receiving content from the Button and streaming towards the display.</li> <li>during the first phase of the Base Unit boot process.</li> </ul>
blinking white	<ul style="list-style-type: none"> <li>system is starting up (during the second phase)</li> <li>Button pairing is in progress</li> <li>software update of the Base Unit</li> </ul>
breathing white	<ul style="list-style-type: none"> <li>ECO standby mode</li> </ul>
static white	<ul style="list-style-type: none"> <li>awake and ready (i.e. showing the welcome message on the display)</li> <li>pairing and software update of the Button is done, you can now unplug the Button from the Base Unit..</li> </ul>
red blinking	<ul style="list-style-type: none"> <li>an error occurred</li> </ul>
dark	<ul style="list-style-type: none"> <li>deep standby/off</li> </ul>

## Back layout of the Base Unit

The connection panel is situated at the back of the Base Unit.

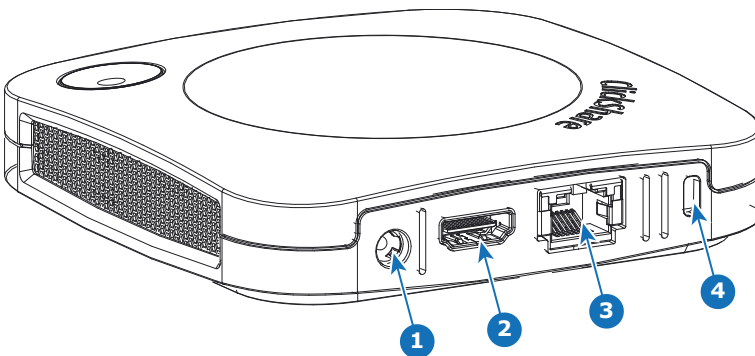

Image 1–4

1	Power connection
2	HDMI out
3	LAN Ethernet connection
4	Kensington lock

## Mechanical fixture points

The mechanical fixture points are located at the bottom of the Base Unit.

## Antenna

The antenna is built-in in the C-5, C-10.

## Bottom layout of the Base Unit

The serial number label containing the Barco part number, the revision number, production date (week-year) and the serial number.

The product label with the applicable certification logos.

The product label contains:

- the Barco logo
- the product name

- the Barco part number
- the power rating
- markings for applicable standards (CE, CCC, UL, ...)
- markings for waste regulation
- “Made in ...”

## 1.4 Mobile Device Support

### Overview

The below list of Apps are supported by ClickShare and can be installed on your mobile device from Google Play or Apple App Store. Or can be installed on your Windows or Mac pc

Before you can use your mobile device with ClickShare, you have to connect the mobile device Wi-Fi with the ClickShare Base Unit Wi-Fi. Follow the instructions as given in your mobile device user guide. Or connect the Base Unit to the network, then you do not need to switch your Wi-Fi.

App	Used on
ClickShare App	iOS Android Windows Mac OS

Apps can be downloaded from [www.clickshare.app](http://www.clickshare.app) .

# Getting started

# 2

2.1	Environmental Condition Check.....	16
2.2	Security recommendations before starting .....	16
2.3	Basic Workflow.....	17

## 2.1 Environmental Condition Check

### Environment condition check

For installations in environments where the device is subject to excessive dust, then it is highly advisable and desirable to have this dust removed prior to it reaching the device clean air supply. Devices or structures to extract or shield excessive dust well away from the device are a prerequisite; if this is not a feasible solution then measures to relocate the device to a clean air environment should be considered.

It is the customer's responsibility to ensure at all times that the device is protected from the harmful effects of hostile airborne particles in the environment of the device. The manufacturer reserves the right to refuse repair if a device has been subject to negligence, abandon or improper use.

### Ambient temperature conditions

Max. ambient temperature : +40°C or 104°F

Min. ambient temperature: +0°C or 32°F

Storage temperature: -10°C to +60°C (14°F to 140°F)

### Humidity Conditions

Storage: 0 to 90% relative humidity, non-condensing

Operation: 0 to 85% relative humidity, non-condensing

### Environment

Do not install the device in a site near heat sources such as radiators or air ducts, or in a place subject to direct sunlight, excessive dust or humidity. Be aware that room heat rises to the ceiling; check that temperature near the installation site is not excessive.

## 2.2 Security recommendations before starting

### Keep your Base Units and Buttons up to date

Barco keeps improving their devices, this means extending existing features and adding new ones, but also providing security patches. Therefore, it is strongly recommended to keep the Base Units up to date with the latest available firmware, and ensure Buttons are updated. Always updating your device to the latest firmware. Therefore, it is strongly recommended to connect your device to internet to get automatic updates.

To insure an update of all Buttons, Barco strongly recommends pairing all Buttons with the corresponding Base Unit immediately after the Base Unit has been upgraded.

### XMS platform

Manage Base Units through XMS (Cloud) management Platform to receive updates.

XMS is Barco's secure cloud-based solution for the configuration, remote management and real-time status monitoring of your devices, distributed over different locations. Enjoy easy & automated (scheduling of) software updates, Base Unit configuration, creation of templates, remote wallpaper installation, user management and insights to drive Digital Workplace.

### Keep Base Units locked away

In case you expect physical tampering of the hardware by malicious people Barco recommends keeping the Base Units locked away.

### Change the default Wi-Fi password

Barco strongly recommends changing the default Wi-Fi password (only applicable when WPA2-PSK mode is used), this makes it again one step more difficult for malicious people, without physical access to your devices, to intercept the traffic between Button and Base Unit.

## Change the default Configurator password

Barco strongly recommends changing the default Configurator password. Anyone with malicious intentions who can access the Base Unit locally or via adjacent networks will definitely verify if the Base Unit's Configurator can be accessed to extract valuable information like e.g. Wi-Fi credentials.

## 2.3 Basic Workflow

### Before using C-5, C-10

1. Unpack your device and accessories from the box.  
For a detailed overview of the content of the C-5, C-10 box, see [“C-5, C-10 specifications”](#), page 9
2. Install the Base Unit in the meeting room using one of the possible installation methods.  
For more information on the installing procedures, see [“Installation methods for the Base Unit”](#), page 20
3. Connect the video signal between the Base Unit and the display, see [“Video signal connections to the Base Unit”](#), page 27.
4. Connect the Base Unit to the mains power.  
For more information, see [“Power connection”](#), page 28,
5. Connect a network cable between the Base Unit and the local network (make sure the Base Unit is connected to the internet to be able to reach the update server )
6. Configure your device (can be used without configuration but is not recommended).
7. Register you device online to obtain your SmartCare package.
8. Pair your Button(s), see [“Pairing the Button”](#), page 44



# C-5, C-10 Installation

# 3

3.1	Installation methods for the Base Unit .....	20
3.2	Table mounting .....	20
3.3	Wall or ceiling mounting .....	20
3.4	Out-of-the-box use of the Base Unit .....	22
3.5	Network deployment requirements .....	23
3.6	Network connected setup .....	24
3.7	Dual network connected setup .....	24
3.8	Dedicated network setup .....	25
3.9	Video signal connections to the Base Unit .....	27
3.10	Touch screen connections to the Base Unit .....	27
3.11	LAN connection .....	27
3.12	Power connection .....	28
3.13	First startup of the Base Unit .....	28
3.14	Preferred way to start up .....	29
3.15	Start up without configuration .....	34
3.16	Registration to XMS Cloud .....	35
3.17	Activating calendar integration with XMS Cloud .....	37

## 3.1 Installation methods for the Base Unit



For optimal performance, install the Base Unit close to the display and avoid obstacles between the Base Unit and the Buttons.



Make sure not to install the Base Unit in a metal enclosure.

### Physical installation

The Base Unit can be installed in different ways in a meeting room.

- Table mount
- Wall mount
- Ceiling mount

### Standalone or network integration

The Base Unit can be used as standalone unit or integrated in a corporate network.

- Out-of-the-box use
- Out-of-the-box use with Ethernet link
- Integration in enterprise network
- Dual network integration
- Integration in dedicated enterprise network

## 3.2 Table mounting

### Overview

Put the Base Unit directly on the meeting room table.

The total weight of the Base Unit is 530 g.

## 3.3 Wall or ceiling mounting

### About wall or ceiling mounting

A mounting base is used to mount the C-5, C-10 to the wall or ceiling. This base has key-shaped screw holes to allow you to fasten the base to a wall or ceiling or you can use the self-adhesive layer to mount the base. Once you determine the location for your device follow the next procedure to mount the device.

### Mounting with screws

1. Take the mounting base out of the package.
2. Place the mounting base on the wall or ceiling and mark the screw holes (1).



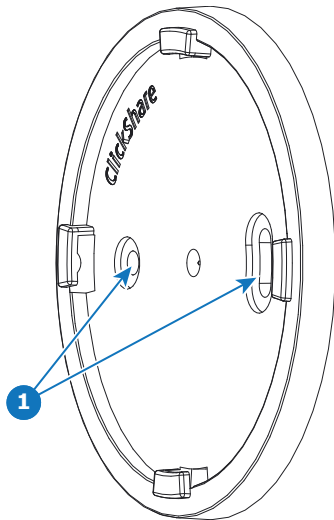

Image 3-1

3. Select a drill bit slightly smaller than the size of the used anchors to ensure a snug fit.
4. Drill the holes where marked.
5. Tap plastic screw anchors into the drill holes with a hammer (if needed, depending on the wall or ceiling type).
6. Place the mounting base on the ceiling or wall, drive in the screws.
7. Place your device on the mounting base and turn it clockwise until it is locked.

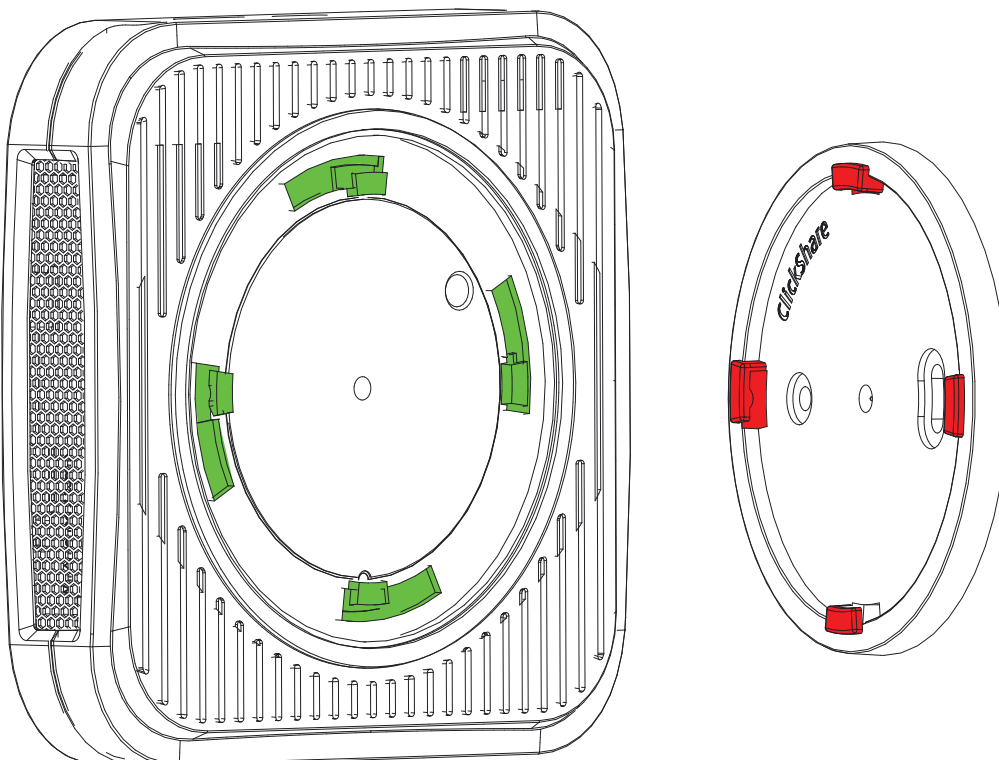

Image 3-2

### Mounting with the self-adhesive layer

1. Peel off the removable protection foil.

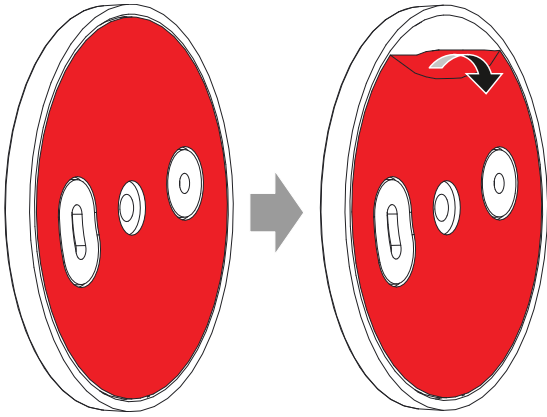

Image 3-3

2. Stick the base on the chosen location.
3. Place your device on the mounting base and turn it clockwise until it is locked ([Image 3-2](#)).

## 3.4 Out-of-the-box use of the Base Unit

### Overview

This setup is the simplest in terms of installation and can be used for temporary setups and in organizations where central management and 3rd party integration are not required.

The ClickShare Base Unit and Button operate directly out of the box, without any integration in the Enterprise network. The Base Unit should be connected to the internet at least once to update and to register. Users can connect directly to the Base Unit via the ClickShare Button, using the ClickShare App or Miracast or with their mobile devices using Airplay or Google Cast.

Using a ClickShare Button allows you to stay connected to the internet. Using the ClickShare App, Airplay or Google Cast will require connecting to the Base Unit directly and will only be able to access the internet if the device supports to use data (3G/4G) at the same time. Note that this requires the Base Unit's access point is not turned off, is visible and can be connected to by anyone.

Sharing via Miracast will only be possible via Wi-Fi direct.

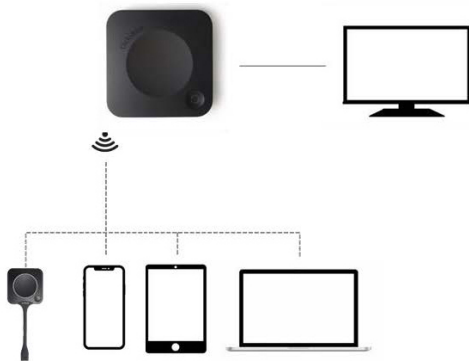

Image 3-4

Using the ClickShare Base Unit and Button directly out of the box is ideal for temporary setups, visitor centers and small to medium installations without network integration needs or possibilities. This setup requires the least installation effort and keeps any shared data completely separated from your Enterprise network. Updating and configuring the Base Units will need to be done manually.

## 3.5 Network deployment requirements

### General

This topic contains recommendations for integrating our device into your enterprise network. A detailed overview is given in terms of minimal requirements and required ports and firewall rules needed to be configured to make the specific function work.

### Base Unit: first-time setup

- **Activation and update:** for this action, similar to the auto-update functionality described below, an outbound TCP connection on port 443 is required towards `update.cmp.barco.com` and `assets.cloud.barco.com`.
- **Connection to XMS Cloud** for activating SmartCare and XMS Cloud functionality: TCP Port 443 outbound to `*.azure-devices.net`, `*.core.windows.net` and `global.azure-devicesprovisioning.net`.

The first-time setup requires a laptop with access to:

- XMS Cloud: outbound TCP Port 443 to `xms.cloud.barco.com`
- MyBarco portal: outbound TCP Port 443 to `*.barco.com` (`login/xms.cloud.barco.com`).
- (Optional) Web Configurator of the device: TCP ports 80 and 443 to the Base Unit or ability to connect directly to the Base Unit's Wi-Fi.

### Overview of the required ports

Open the following ports on your network to ensure that you can share content via ClickShare:

Sender/Receiver		Ports
ClickShare Button (wireless presentation)	TCP	2345, 6544
	UDP	
ClickShare Desktop and Mobile Apps (wireless presentation)	TCP	6541-6545
	UDP	5353, 1900
Additional ports for Wireless Conferencing (Button or Desktop App)	TCP	1235, 9999
	UDP	1234
AirPlay	TCP	4100-4200, 7000, 7100, 47000
	UDP	4100-4200, 5353
Google Cast	TCP	8008, 8009, 9080
	UDP	1900, 5353, 32768, 61000 <sup>5</sup>
Miracast MS-MICE	TCP	7236, 7250
	UDP	7236
ClickShare Configurator	TCP	80, 443
	UDP	n/a
XMS Cloud	TCP	443
XMS Edge	TCP	4003
Auto-update	TCP	80, 443
	UDP	n/a

5. Google Cast will pick a random UDP port above 32768 to facilitate video streaming.

Sender/Receiver		Ports
SNMP	UDP	161 and 162
REST API	TCP	4003

## 3.6 Network connected setup

### Overview

This is the simplest installation which offers a seamless experience for employees and is the recommended setup for temporary setups, visitors' centers, small to medium installations without network integration needs, for internal meeting rooms, for companies with a flat network topology or when the ClickShare Button will be the main way for people to the system.

In this default mode, the ClickShare Button and Base Unit operate directly out of the box (Button must be paired to the Base Unit before it can be used) and users can share to the Base Unit with the ClickShare Desktop App, the ClickShare Mobile App, AirPlay, Google Cast via the network to which the Base Unit is connected without losing the internet connectivity. Sharing via Miracast depends on the configuration of the device.

Using a ClickShare Button allows guests to stay connected to the Guest LAN and thus retain internet connectivity. Guest mobile devices will usually need to connect to the Base Unit directly and will only be able to access the internet if the device supports to use data (3G/4G) at the same time.

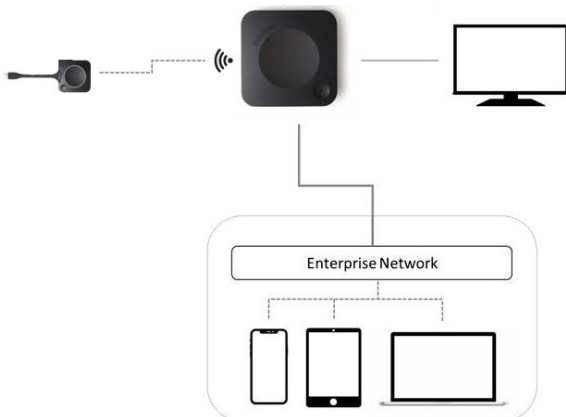

Image 3-5

## 3.7 Dual network connected setup

### Overview

This installation offers a seamless experience for employees and guests and is the recommended setup for any organization with an advanced network configuration, for meeting rooms which will be frequently used by guests, visitors and externals or when the ClickShare Apps and native BYOD protocols, such as AirPlay, Google Cast and Miracast, will be frequently used in the organization.

For the C-5, C-10, the dual network connection topology will disable the access point of the Base Unit and Buttons must connect to the Base Unit via Corporate access points.

Note that Wireless Conferencing capabilities of the ClickShare Button might be limited when the Button is integrated into the corporate network, and its performance will depend on the internal network.

Users can share to the Base Unit with the ClickShare Desktop App, the ClickShare Mobile App, AirPlay, Miracast and Google Cast via either network to which the Base Unit is connected.

Miracast MS-MICE will only be available through the LAN connection, all other devices will connect to the Base Unit directly over Wi-Fi direct.

ClickShare Base Units can be integrated into a dedicated network or VLAN, however, dedicated firewall rules need to be applied to allow the streams to go through the different network sections.

Connecting the Base Unit to the Enterprise network opens the possibility for using the eXperience Management Suite (XMS) for central management and/or using the auto-update functionality to keep your installed Base Unit up to date.

A Base Unit which is connected to the network, can be monitored through SNMP, can be controlled and monitored by other 3rd party systems such as Crestron or can be interfaced through the ClickShare Conference REST API.

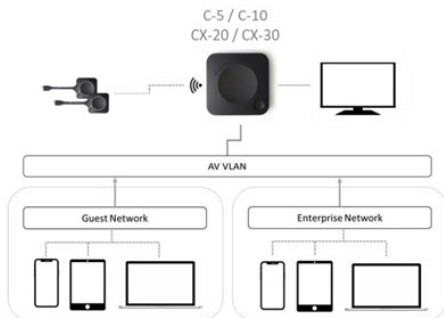

Image 3-6

## How to setup via the Configurator

1. Connect the Base Unit and browse to the *ClickShare Configurator* and log in.
2. Select *Button* in the *System* menu and click **Edit settings**.  
Select *External Access Point* from the drop down menu and select the preferred authentication mode and fill out the details.  
Click **Save Changes**. For more information, see [“Buttons”, page 90](#)
3. Pair the Buttons again with the Base Unit.
4. Optionally the Base Unit’s WiFi can be set to Access Point or can be set to Off. For more info, see [“Wi-Fi settings, Wireless Client”, page 66](#)

## Setup via XMS

1. Log in to XMS and go to the *Base Units* tab.
2. In the device list select the Unit(s) for deploying network integration mode.
3. Open the *Configure* dropdown list and choose *Network integration*.
4. Select one of the authentication modes for network integration mode and fill out the details.
5. Re-pair the ClickShare Buttons with the updated Base Unit(s) to apply the new configuration  
For more detailed information on how to use XMS, consult the XMS user guide.

# 3.8 Dedicated network setup

## Overview

This installation offers an isolated network setup where all connections from and to the Base Units can be controlled. This dedicated AV (or ClickShare) network or VLAN can be used for more fine-grained access control, to ensure no connection can happen between any of the connected physical or virtual LANs or to separate all ClickShare traffic from all other IP traffic to ensure business requirements in terms of bandwidth, security and latency.

In this setup, the configurations can widely differ depending on network topology and security requirements in the organization. Here, we will describe a simple setup where the Base Unit is placed in a dedicated AV VLAN, a commonly used practice within organizations.

In this setup, ClickShare Buttons and Base Unit operate directly out of the box (Buttons must be paired to the Base Unit before they can be used)). Since the Base Unit has been installed in a dedicated network, firewall configuration will be required to enable the use of the ClickShare Desktop App, the ClickShare Mobile App, AirPlay and Google Cast over the network

If the firewall is not configured to allow connections from either the guest Wi-Fi or the employee Wi-Fi, users can connect to the wireless access point of the Base Unit to share with the ClickShare Desktop App, ClickShare Mobile App, AirPlay and Chromecast and will only be able to access the internet if the device supports to use data (3G/4G/5G) at the same time. Note that this requires that the Base Unit's access point is not turned off, is visible and can be connected to by anyone. Mobile users are limited to the experience described in the standalone setup. For Miracast, the Base Unit will have to be configured for Miracast to offer a Wi-Fi direct connection.

Connecting the Base Unit to the Enterprise network opens the possibility for using the eXperience Management Suite (XMS) for central management and/or using the auto-update functionality to keep your installed base up to date.

A Base Unit which is connected to the network, can be monitored through SNMP, can be controlled and monitored by other 3rd party systems such as Overture or Crestron or can be interfaced through the ClickShare REST API.

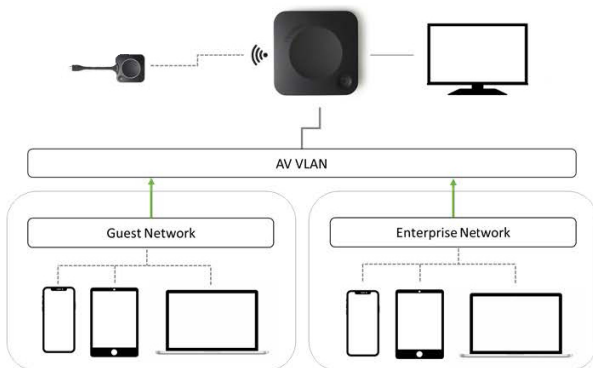

Image 3-7

## How to setup via the Configurator

1. Connect the Base Unit and browse to the *ClickShare Configurator* and log in.
2. Select *Button* in the *System* menu and click **Edit settings**.

Select *External Access Point* from the drop down menu and select the preferred authentication mode and fill out the details.

Click **Save Changes**. For more information, see [“Buttons”, page 90](#)

3. Pair the Button again with the Base Unit.
4. Optionally the Base Unit's WiFi can be set to Access Point or can be set to Off. For more info, see [“Wi-Fi settings, Wireless Client”, page 66](#)

## Setup via XMS

1. Log in to XMS and go to the *Base Units* tab.
2. In the device list select the Unit(s) for deploying network integration mode.
3. Open the *Configure* dropdown list and choose *Network integration*.
4. Select one of the authentication modes for network integration mode and fill out the details.
5. Re-pair the ClickShare Button with the updated Base Unit(s) to apply the new configuration

For more detailed information on how to use XMS, consult the XMS user guide.

## 3.9 Video signal connections to the Base Unit

### About Video signal connection

A single screen can be connected to the Base Unit.

To connect a display, an HDMI connection should be made between the Base Unit and the display.

### To connect

1. Connect the Base Unit to the display using a display cable.

 **Note:** No display cables are included in the ClickShare box at purchase.

When setting up a display configuration, connect the HDMI cable to the display. When necessary, use an adapter piece to connect to a display port or a DVI port on the display side.

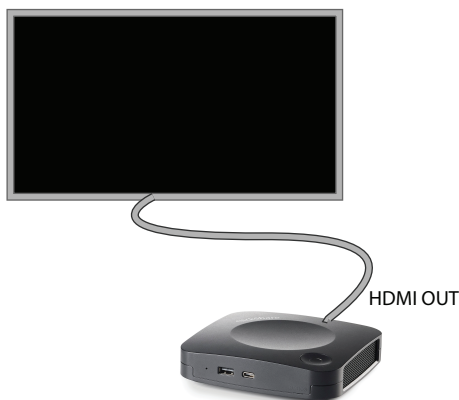



Image 3–8 Display connection

## 3.10 Touch screen connections to the Base Unit

 Only available on C-10.

### About the connection

A single screen can be connected to the Base Unit.

To connect video, an HDMI connection should be made between the Base Unit and the display. To connect the touch functionality, a USB cable should be connected between the touch screen and the Base Unit. A list of supported touch screens can be found on Barco's website. See <https://www.barco.com/en/support/docs/TDE9538>.

### To connect

1. Connect a HDMI cable between the Base Unit and touch screen display. When necessary, use an adapter piece to connect to a display port or a DVI port on the display side.
2. Connect the USB output of the touch screen with a USB connector on the Base Unit.

## 3.11 LAN connection

### About LAN connection

The Base Unit can be connected to a local network or directly to a laptop.

Maximum allowed LAN speed: 1000 Mbit

We do strongly advise the LAN connection and the use of XMS cloud for configuration, monitoring and additional functionality. The LAN connection also greatly improves the user experience when using the ClickShare Apps and native sharing protocols such as Airplay and others.

## How to connect

1. Insert a network cable with RJ-45 connector into the LAN port.
2. Connect the other side to a LAN.

## 3.12 Power connection

### About power

An external power adapter is delivered with the product. The output rate is 12 VDC 2A.



**CAUTION:** Once the Base Unit is powered, it starts up. Then the power button can be used to switch on or off.

### How to connect the external power adapter

1. Plug the barrel connector of the power adapter into the power input of the Base Unit.
2. Slide a power input adaptor piece (US, AU, IN, CH, EU or UK) on the power adapter of the ClickShare until it clicks. Use the one which is applicable in your country.



Image 3-9 Power adapter

3. Connect the power cable to the wall outlet.

## 3.13 First startup of the Base Unit

### Workflow

1. First time boot of the Base Unit.  
The following screen is seen on the connected monitor.



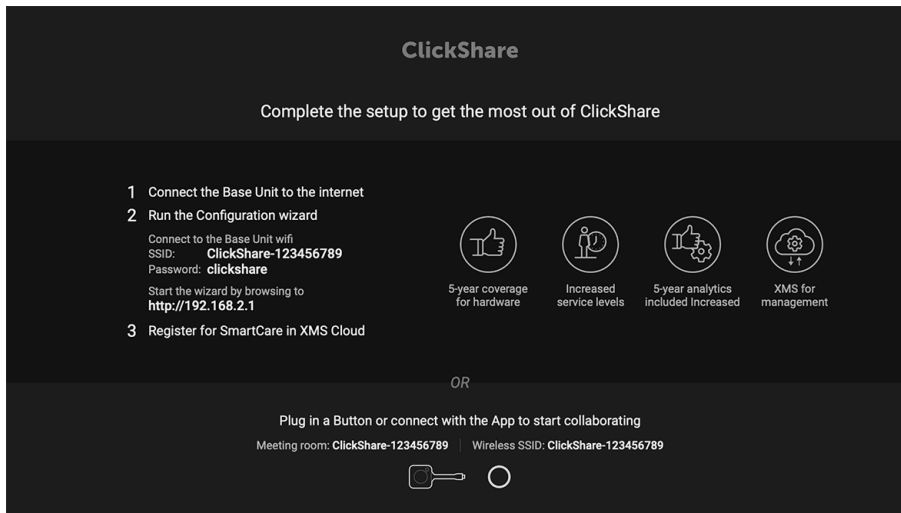

Image 3–10 Onboarding screen

There are now 2 ways to continue:

1. Check for updates (optional), configure your Base Unit and register to XMS Cloud. See “Preferred way to start up”, page 29
2. Plug in a button and start sharing your screen. See “Start up without configuration”, page 34

## 3.14 Preferred way to start up

### What will be done?

After an optional firmware update check, the configuration wizard should be started to configure the Base Unit. To finalize the complete startup, the Base Unit can be registered to XMS Cloud to get your SmartCare package. That package contains a 5-year coverage for hardware, increased service levels, 5-year analytics and XMS for management.

### How to handle

1. Connect the device's WiFi with the given instructions.  
The default SSID is ClickShare-<serial number>.  
Password : clickshare
2. Once your WiFi connection is made, continue with the network setting of your device.  
Browse to <http://192.168.2.1>  
The ClickShare Configurator wizard starts up.

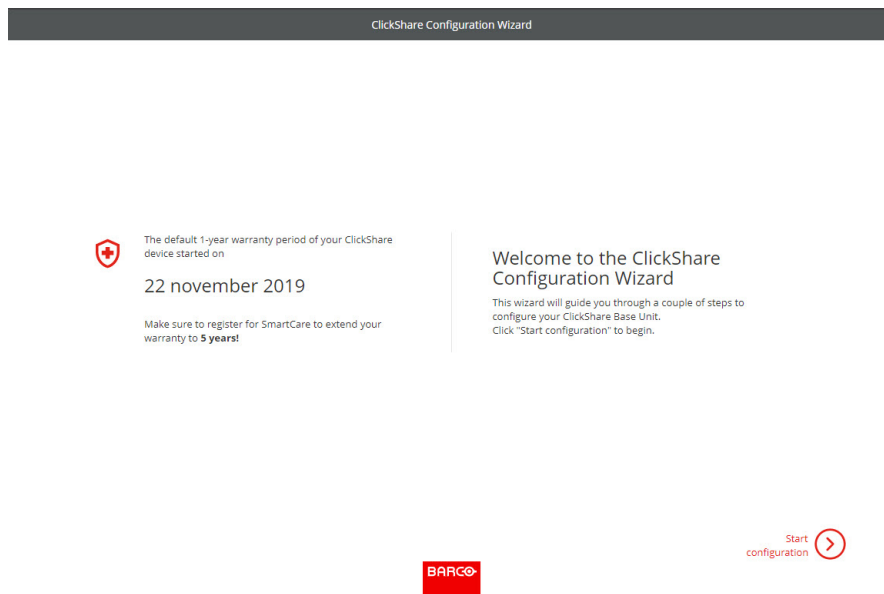

Image 3–11

### 3. Click **Start configuration**.

The *Firmware* update window opens.

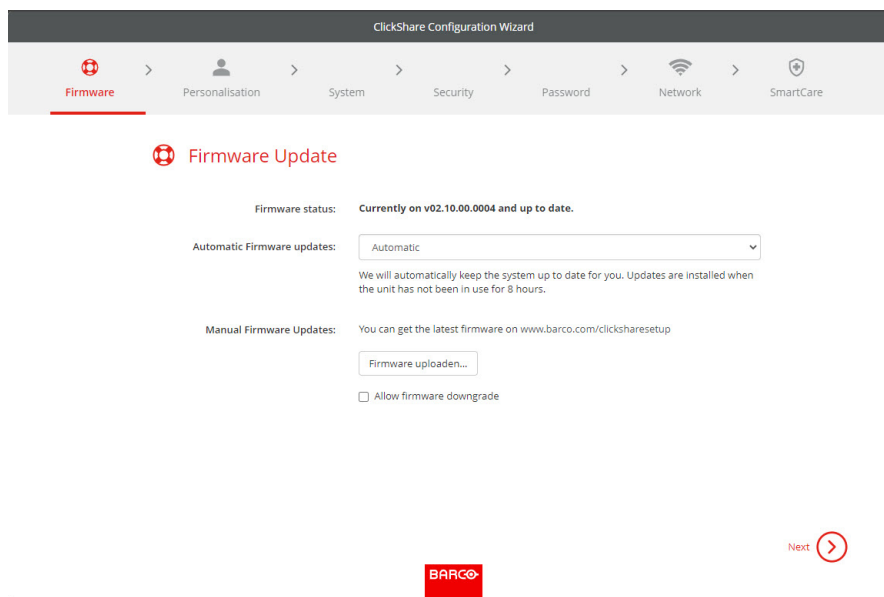

Image 3–12

When connected to the internet you can select *Automatic* for firmware update (recommended). If you set it on *No*, you still have the choice to manually update by downloading the software on an USB stick.

When connected to the internet and the setting is set to *Automatic*, the software check will be done and the latest version will be downloaded but the update of the firmware will be executed only when finishing the configuration wizard.

For more info about automatic firmware update, see [“Firmware Update”, page 98](#).

Click **Next** to continue to the next page and **Back** to return to the previous page.

### 4. Personalisation step.

ClickShare Configuration Wizard

Firmware > **Personalisation** > System > Security > Password > Network > SmartCare

**Personalisation**

Language for on-screen text: English

Meeting room name: ClickShare-1863550386

Location name: Enter the name of the location

Welcome message: Welcome to

Back Next

BARCO

Image 3–13

Enter the on screen language you want to use. For more info, see [“On-Screen ID information”](#), page 56.

Enter the meeting room name, location name and welcome message. For more info, see [“On-Screen ID information”](#), page 56.

## 5. System settings

ClickShare Configuration Wizard

Firmware > Personalisation > **System** > Security > Password > Network > SmartCare

**System**

Current time: di. 14 sep. 2021 12:58 (+02:00)

Time zone: UTC-02:00 GMT+2

Mode for setting date and time:  Set date and time manually  Use NTP

Date: 2021-09-14

Time: 12:58:15

Back Next

BARCO

Image 3–14

Enter a time zone and make a selection between manual time setup and the use of NTP.

For more info about manual time setup, see [“Date & Time setup, manually”](#), page 87.

For more info about the use of an NTP server, see [“Date & Time setup, time server”](#), page 89.

## 6. Security settings

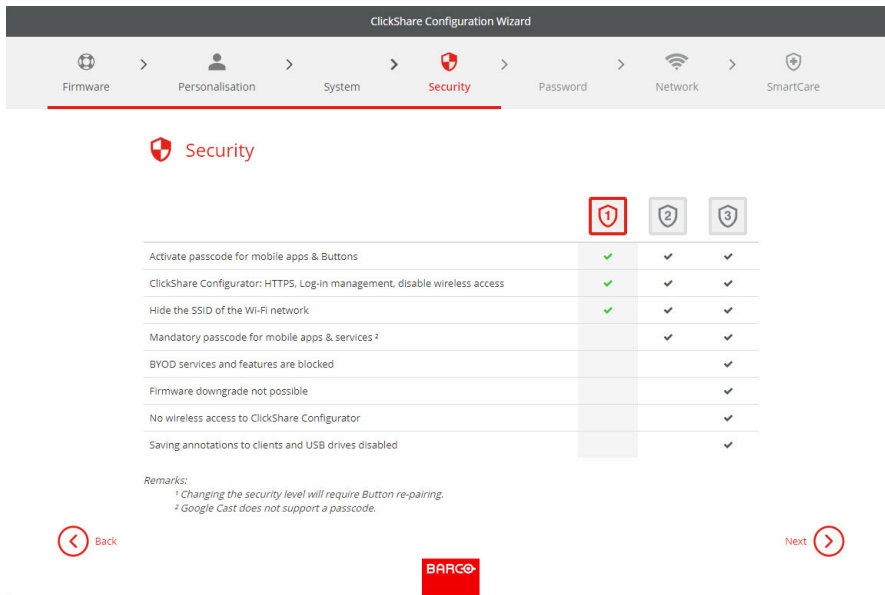

Image 3–15

Set the desired security level. For more info, see [“Security, security level”](#), page 82.

**7. Password change**

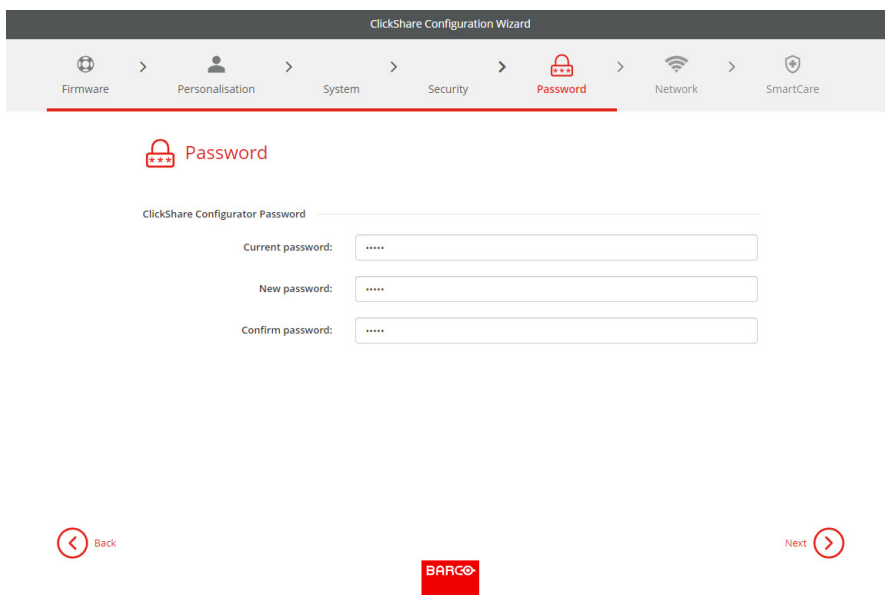

Image 3–16

We advise to change the default password to enter the Configurator. For more info, see [“Security, passwords”](#), page 84.

**8. Network settings**

The screenshot shows the 'ClickShare Configuration Wizard' interface. The navigation bar at the top includes: Firmware, Personalisation, System, Security, Password, **Network**, and SmartCare. The 'Network' section is active and displays the following settings:

- Frequency band: 5 GHz
- Channel: 36
- SSID: ClickShare-1863550386
- Broadcast SSID
- New Wi-Fi passphrase: Enter a new passphrase
- Confirm Wi-Fi passphrase: Confirm the passphrase

At the bottom of the screen, there are 'Back' and 'Next' navigation buttons, and the BARCO logo is centered.

Image 3–17

Select the frequency band, channel and enter a Wi-Fi passphrase when desired. For more info, see [“Wi-Fi settings, Access Point settings”](#), page 64.

## 9. SmartCare registration

The screenshot shows the 'ClickShare Configuration Wizard' interface. The navigation bar at the top includes: Firmware, Personalisation, System, Security, Password, Network, and **SmartCare**. The 'SmartCare for ClickShare' section is active and displays the following information:

- SmartCare for ClickShare**
- SmartCare is a service package included in the purchase of each ClickShare Conference and ClickShare Present unit. SmartCare can be claimed when the unit is registered to Barco or added via the central management solution.
- Benefits:
  - 5-year coverage for hardware
  - Increased service levels
  - XMS for management
  - 5-year analytics management
- More info: <https://www.barco.com/en/clickshare/apps-accessories/smartcare>
- To add your device to SmartCare, visit XMS cloud: <https://xms.cloud.barco.com/add>
- Device Token: 2GA5G6XH

At the bottom of the screen, there are 'Back' and 'Next' navigation buttons, and the BARCO logo is centered.

Image 3–18

To benefit from the SmartCare program, your device should be registered to XMS Cloud. Copy your device token by clicking on the copy icon next to the token.

Click on the link to start the registration procedure.

Follow the procedure in [“Registration to XMS Cloud”](#), page 35.

## 10. Overview page

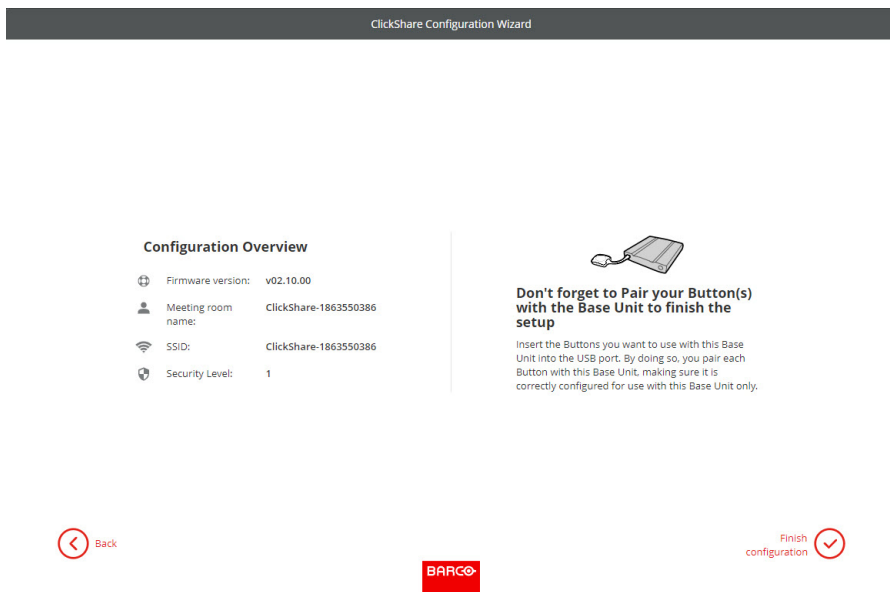

Image 3–19

Gives an overview of the current configuration.

Click **Finish configuration**. When your device is connected to the internet and firmware update was set to automatic, a software check and an update will be executed. The Configurator starts automatically with a message that your device is configured.

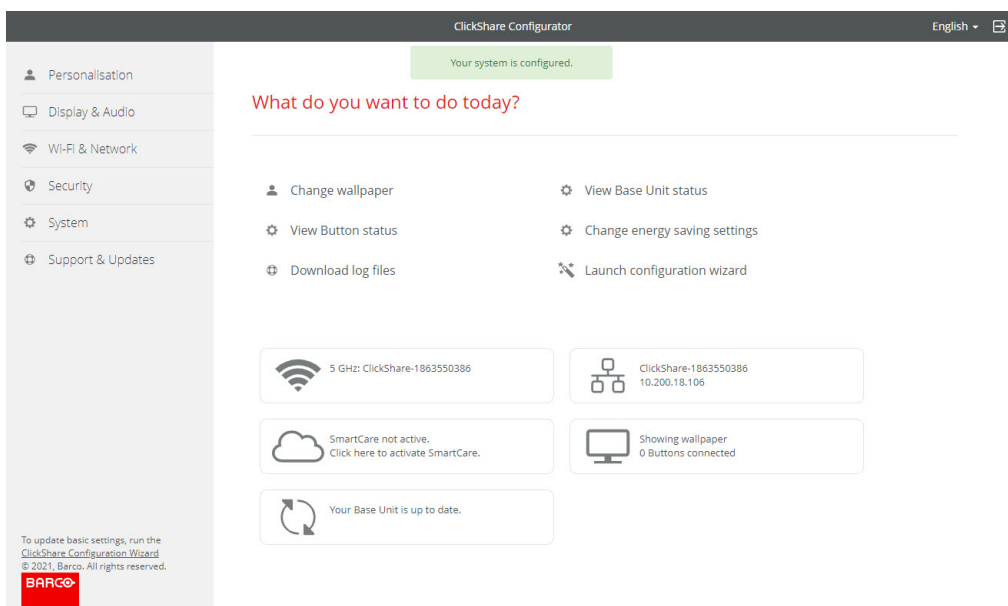

Image 3–20

## 3.15 Start up without configuration

### How to start

1. Plug in a Button and start sharing your screen.

As soon as a user connects to the Base Unit, the default wallpaper will be shown on the meeting room display and the unit can be used with its default configuration. However, as long as the Configuration Wizard has not been completed, the initial startup screen will again be shown at each reboot of the device.

Registration of the device is only possible in the Configuration Wizard or from the ClickShare Configurator and when the Base Unit is connected to the internet.

## 3.16 Registration to XMS Cloud

### About registration

When your device is connected to the internet and updated you can start to register your device. You have to register your device in order to claim your 5 years SmartCare package.

This SmartCare package includes:

- 5-year coverage for hardware
- Increased service levels
- XMS for management
- 5-year analytics management

More info can be found on <https://www.barco.com/en/clickshare/apps-accessories/smartcare>.

Registration can be done to

- XMS cloud by the end customer (preferred flow) or by the reseller in the name of the customer.

### Online to XMS cloud

1. Surf to <https://xms.cloud.barco.com/add>.  
The XMS login page is displayed.
2. Enter your Email address and click **Continue**.

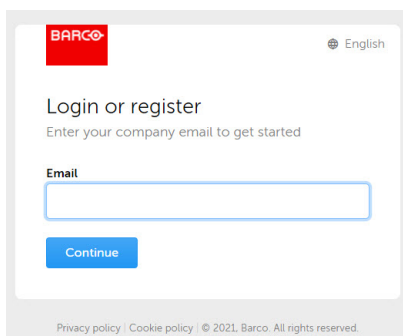

Image 3–21

When your E-mail address is known by XMS Cloud you arrive on the tenant selection page. To continue, go to step 5.

When your E-mail address is not known by XMS Cloud, a verification code will be sent to the entered E-mail address. Enter the verification code and click **Continue**.

The XMS cloud welcome page is displayed.

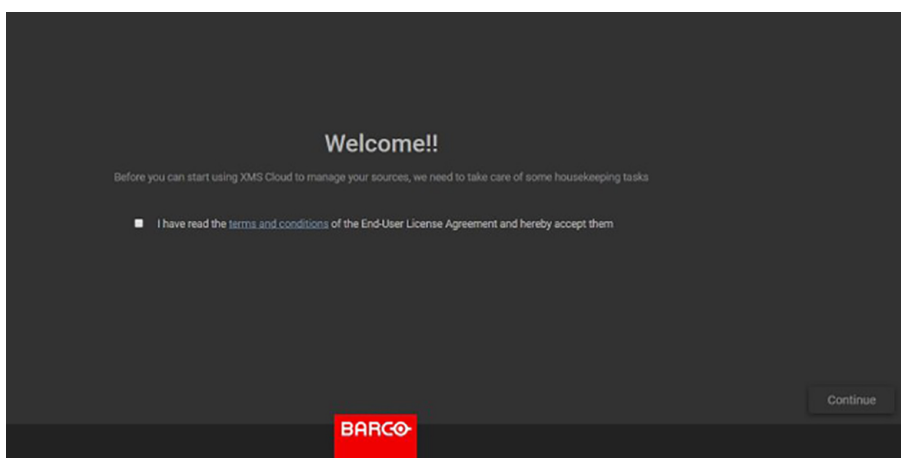
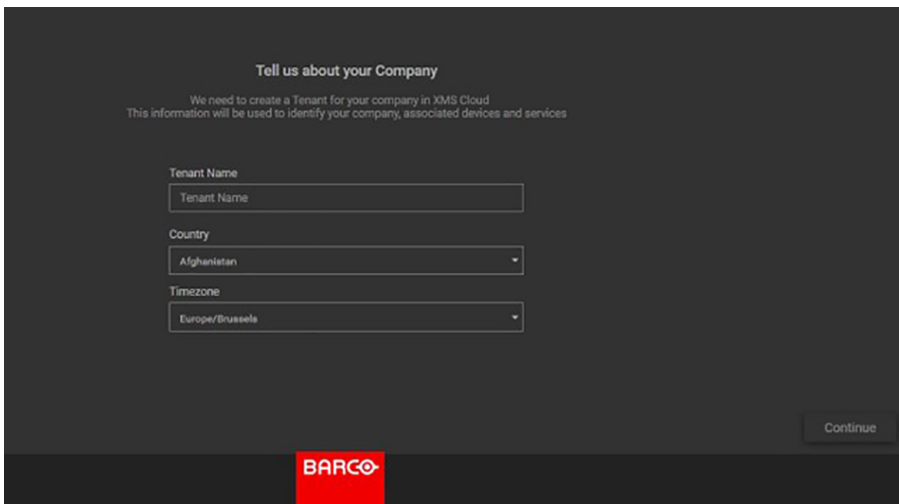

Image 3–22 Welcome page to XMS-cloud

3. Accept the End User License agreement and click **Continue**.

4. Fill out your company information and click **Continue**.



The screenshot shows a dark-themed web form titled "Tell us about your Company". Below the title, there is a sub-header "We need to create a Tenant for your company in XMS Cloud" and a note "This information will be used to identify your company, associated devices and services". The form contains three input fields: "Tenant Name" (a text box with "Tenant Name" inside), "Country" (a dropdown menu with "Afghanistan" selected), and "Timezone" (a dropdown menu with "Europe/Brussels" selected). A "Continue" button is located in the bottom right corner. The BARCO logo is visible at the bottom center of the form area.

Image 3–23 Company information

5. Enter the device token to setup your device and to receive your 5 years of service coverage. The device token is indicated on the wizard screen (see [Image 3–19](#))

Click **Continue**.

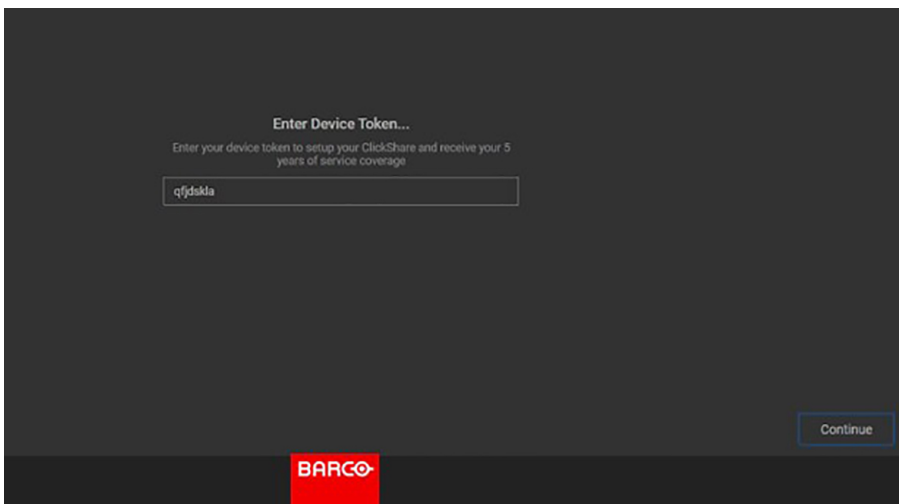

The screenshot shows a dark-themed web form titled "Enter Device Token...". Below the title, there is a sub-header "Enter your device token to setup your ClickShare and receive your 5 years of service coverage". The form contains one input field with the text "qfjdskla" inside. A "Continue" button is located in the bottom right corner. The BARCO logo is visible at the bottom center of the form area.

Image 3–24 Enter device token

6. Assign a meeting room and click **Continue**.



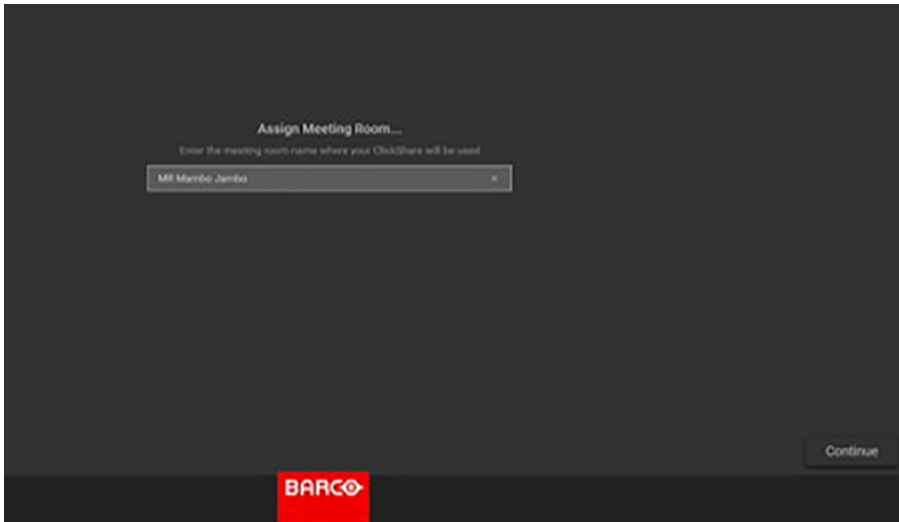

Image 3–25 Assign meeting room

Your device is successfully registered.

## 3.17 Activating calendar integration with XMS Cloud

### About Calendar

The calendar capability allows to display your room calendar on the monitor connected with ClickShare device.

### Before starting

To enable the device to get the calendar, XMS Cloud needs to be “connected” to your Microsoft Azure Account. This ‘connection’ makes it possible to discover your rooms and share their credentials with the devices.

Approval from your organization's O365 admins are required.

### Secure Azure AD integration

XMS Cloud can be used to display the availability of the meeting room on the screen using ClickShare (optional feature). This is done securely using Azure Enterprise Applications that integrate with Azure AD. To mitigate security risks that might arise while integrating Azure Enterprise Applications in Azure AD, this feature makes use of 2 separate Azure Enterprise Applications, the ‘ClickShare Meeting Room Discovery’ and the ‘ClickShare Calendar Sync’. The ‘ClickShare Meeting Room Discovery’ is a multi-tenant application while the ‘ClickShare Calendar Sync’ is a single tenant application, only hosted in the customer’s Azure AD. The ClickShare Base Units access the calendars only through the single tenant ‘ClickShare Calendar Sync’ using a per customer unique and random client secret. The client secret is created by Microsoft with the following properties: randomly generated and expires automatically after 24 months.

For more in-depth information, see Barco’s Security whitepaper “XMS Cloud and (Virtual) Edge Security Whitepaper” which can be downloaded from Barco’s website.



Verify the publisher (Barco) of the Enterprise Application before adding it to your tenant.



Limit the access of the Enterprise Application ‘ClickShare Calendar Sync’ to only the needed meeting rooms (and no other calendars) using an ApplicationAccessPolicy on Microsoft Exchange Online.

## Before starting with the integration

1. Before starting the integration, contact your IT Admin who has **Global Administrator** role in **Azur Active Directory**. Only that account can enable the integration.
2. Add the required IT Admin to the XMS tenant.
3. Ask the IT admin to sign in to XMS Cloud and browse to the Calendar page and ask him to execute the next *How to setup*.
4. After the How to setup, the customer or the integrator can continue with the procedure *Assign a meeting room to a calendar*.

## How to setup (to be executed by the IT admin)

1. Go to XMS Cloud (<https://xms.cloud.barco.com>) and login with your credentials.
2. Click on the tab *Calendar*.

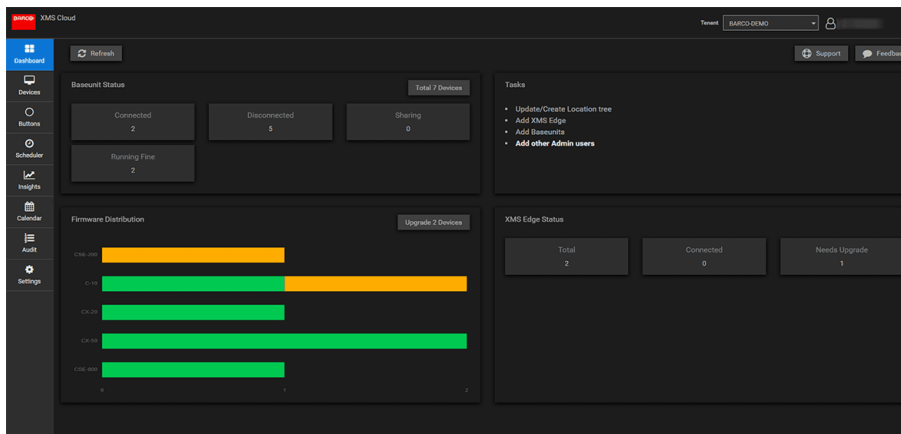

Image 3–26

The calendar connection page opens.

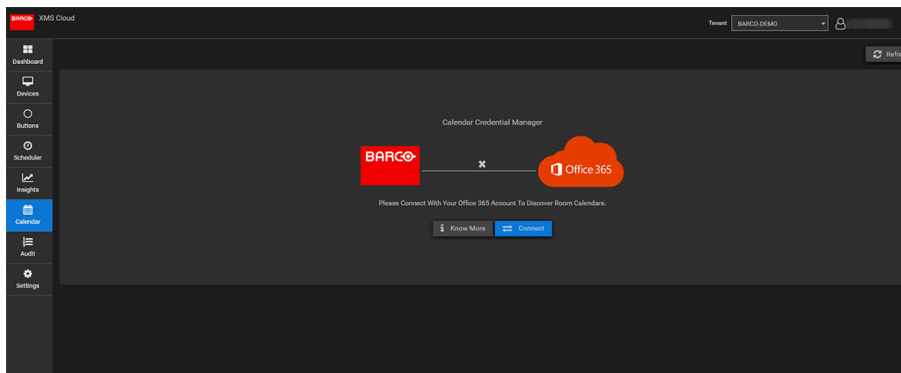

Image 3–27

3. Click **Connect**.  
You will be redirected to your Microsoft Azure account to begin the integration and discover rooms.  
A sign in screen appears.

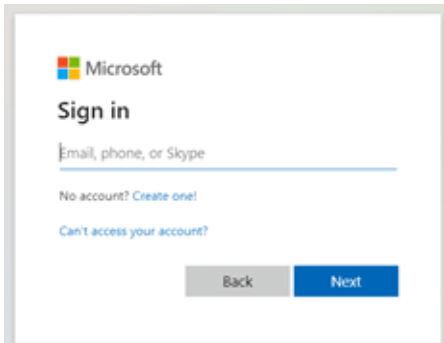

Image 3-28

The IT Admin who has **Global Administrator** role in **Azur Active Directory** should sign in.

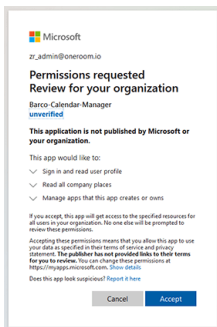

Image 3-29

4. Read the message on the screen and click **Accept**.

When accepted, you are redirected back to XMS Cloud. This process should finish in 10 to 30 minutes but it can take in occasional cases a longer time. The next page is displayed.

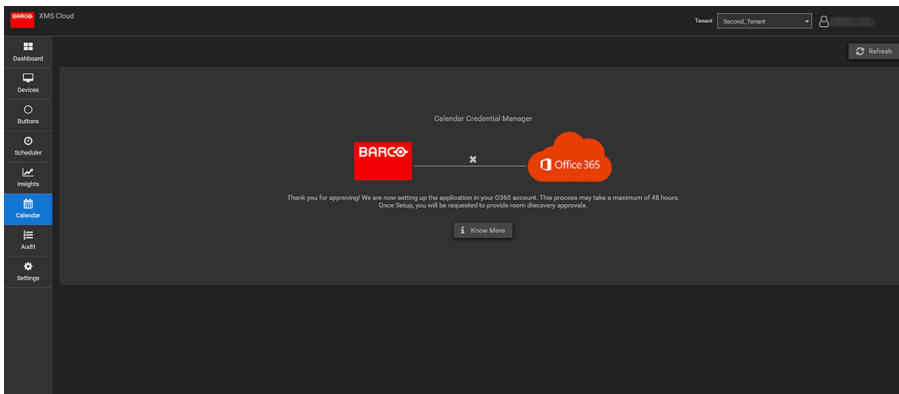

Image 3-30

5. Once the process has finished, the screen is refreshed and shows the **Continue integration** button.

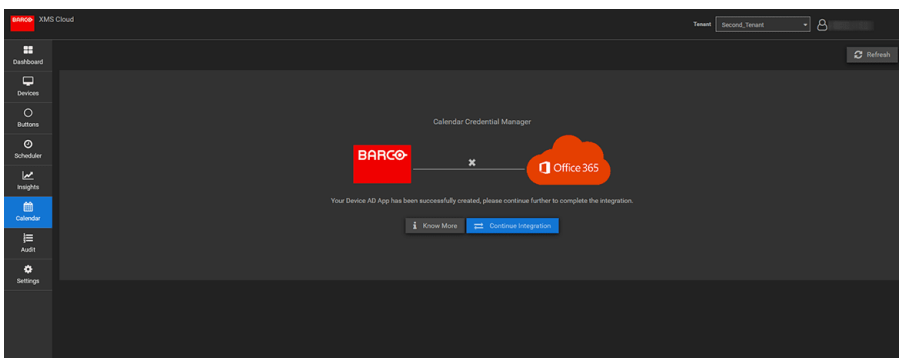

Image 3-31

6. Click **Continue integration** to request the O365 admin's final permission to read calendar information for each room-account and generate credential for devices to achieve that.

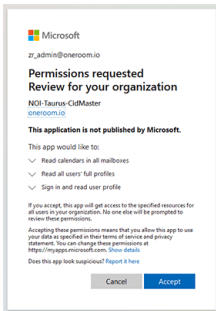

Image 3–32

7. Click **Accept**.

You are redirected to XMS Cloud with the your rooms discovered.

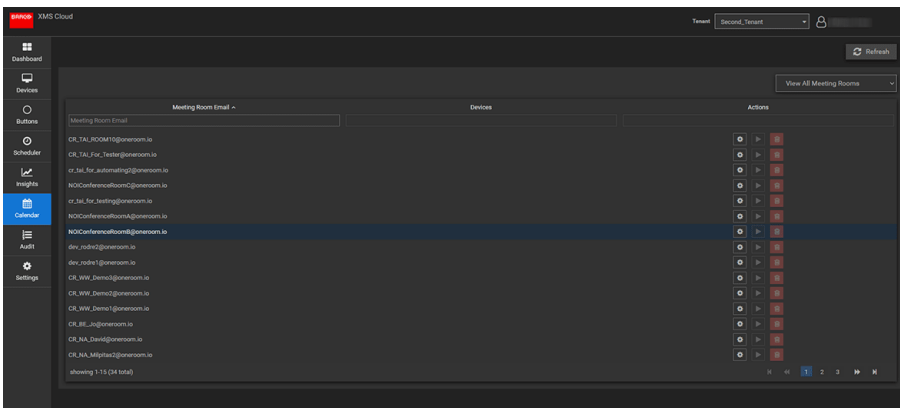

Image 3–33

### Assign a meeting room to a calendar (no devices are mapped yet)

1. Click the *Settings* icon next to the E-mail address of the meeting room.

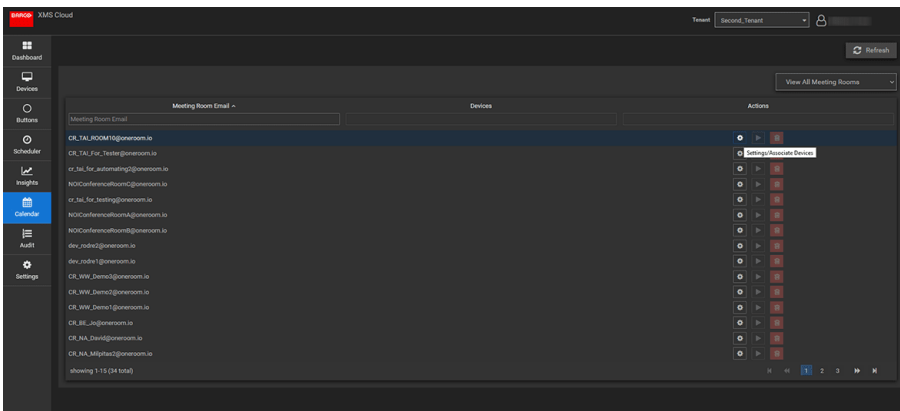

Image 3–34

A popup opens.

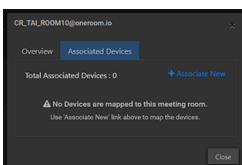

Image 3–35

2. Click on **Associated devices** if not yet selected.

3. Click on **Associate new**.
4. Select your device in the device column and then click outside the box to save the setting.

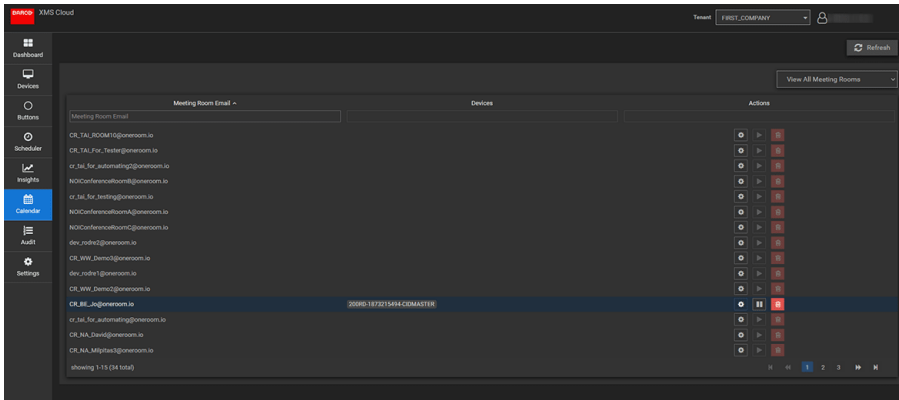

Image 3-36



# Preparing the Buttons

# 4

4.1	Pairing the Button .....	44
4.2	ClickShare Extension Pack .....	44
4.3	ClickShare Extension Pack installer .....	45
4.4	ClickShare Windows Certified driver .....	46
4.5	ClickShare Desktop App .....	46
4.6	MSI installer of the ClickShare Desktop App .....	47

## 4.1 Pairing the Button

### Pairing of the Button with the Base Unit

To be able to use a Button it should be assigned to the Base Unit you are using. This process is called pairing. Each Button will need to be updated and paired before use.

In case you buy additional Buttons or when a Button should be assigned to another Base Unit, the Button needs to be paired (again). The Button software update runs in the background and will not impact users while using the system. When downgrading or updating to an older version of the Base Unit software the Buttons need to be paired manually to update their software.



A Button can only be paired to one Base Unit at a time.  
The Button will always make connection to the Base Unit it was last paired to.

### To pair a Button to the Base Unit by plugging in

1. Insert the Button in the USB type-C™ port available on the Base Unit you are using.

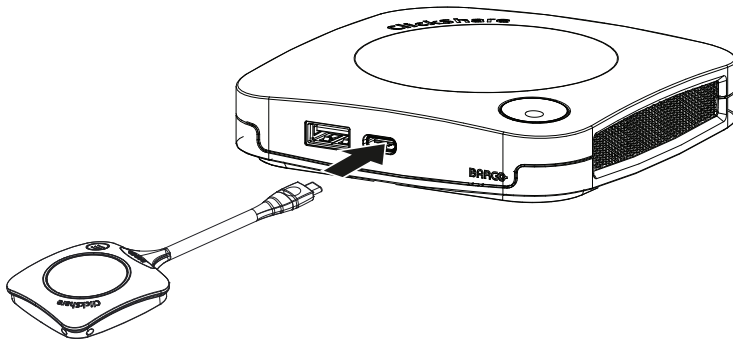

Image 4-1

The Base Unit LED is blinking while the Button LED fills up a circle. This means pairing is in progress.

The Base Unit automatically checks whether the software of the Button is up to date. If not, the Base Unit updates the Button software. This may take more time.

During the pairing and update process, a small status bar is displayed.

The result of the pairing process can be as follows:

- When the LEDs on the Button become green and on static white on the Base Unit, the Button is paired to the Base Unit. You can unplug the Button from the Base Unit.

2. Unplug the Button from the Base Unit.

The Button is now ready for use. Plug in a Button to present.

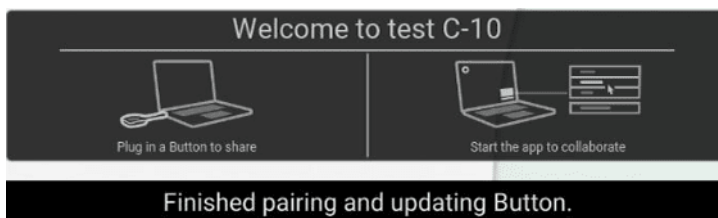

Image 4-2

## 4.2 ClickShare Extension Pack

### About

The ClickShare Extension Pack is a collection of tools to upgrade your ClickShare user experience. This Extension Pack contains the ClickShare Launcher service and a driver to enable the Extended Desktop



functionality (only on Windows). Both tools will be installed by default. To change the default behavior of the installer, the installer will need to be executed with command line parameters.

The ClickShare Extension Pack can be installed by the end user manually, pre-installed on your company's laptop image or deployed company-wide with SCCM or other tools.

The ClickShare Extension Pack can be used in combination with a Button and/or with the ClickShare desktop app.

The latest extension pack can be downloaded via <http://www.barco.com/en/product/clickshare-extension-pack>

## 4.3 ClickShare Extension Pack installer

### Interactive setup

In this setup, the user runs the installer which will install the ClickShare Extension Pack on his computer after the user accepts the EULA.

After the setup finished, the ClickShare launcher will be started automatically. The Extended desktop driver can only be used after the user reboots his computer.

### Starting the setup

1. Download the ClickShare Extension Pack (download via <http://www.barco.com/en/product/clickshare-extension-pack>).
2. Unzip the downloaded file.
3. Click *ClickShare-Extension-Pack.msi* to start the installation.

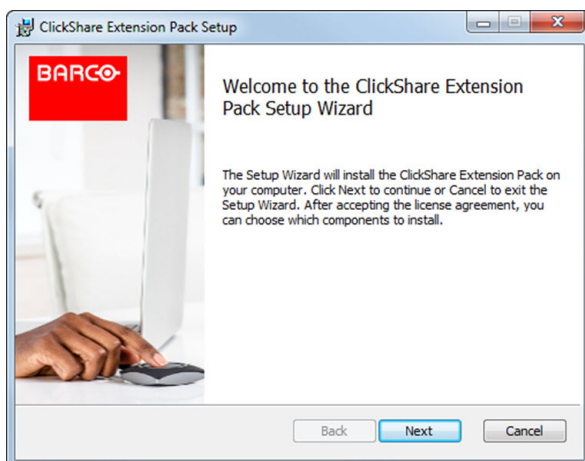

Image 4-3

4. Click **Next**, accept the License Agreement and click **Next** to continue.  
If necessary, follow the on screen instructions.

### Silent setup

In this setup, a user or an IT admin can install the ClickShare Extension pack using the Windows command prompt. Following is an example of a silent installation (version numbers are only given as example, always check Barco's web for the latest version):

Launcher only install:

```
msiexec.exe /i ClickShare-Extension-Pack-01.00.02.0003.msi ACCEPT_EULA=YES INSTALLFOLDER=C:\ LAUNCH_APP=YES /qn
```

Extended desktop only install :

```
msiexec.exe /i ClickShare-Extension-Pack-01.00.02.0003.msi ACCEPT_EULA=YES ADDLOCAL=ExtendedDesktopDriverFeature INSTALLFOLDER=C:\ LAUNCH_APP=YES /qn
```

Full install (launcher + extended desktop):

```
msiexec. exe /i ClickShare-Extension-Pack-01.00.02.0003. msi ACCEPT_EULA=YES  
ADDLOCAL=ALL INSTALLFOLDER=C:\ LAUNCH_APP=YES /qn
```



The computer will reboot. This can be suppressed with /norestart. A reboot will be needed afterwards for the extended desktop feature to be working. In case the end-user should decide if they want to reboot, /promptrestart /QB!+ can be used (basic UI, no cancel option, but prompt to reboot)

### Parameter Description

ACCEPT_EULA	This parameter shows that the installer accepts the EULA text as is. This parameters must be set to YES in order to continue to the installation.
INSTALLFOLDER	This parameter specifies the installation directory for ClickShare launcher. If not specified, the default folder will be the Program Files folder.
LAUNCH_APP	The ClickShare launcher application will be started right after the installation finishes if this parameter is set to YES. Otherwise, the launcher application will not be started.
/qn	This parameter indicates that the installation will be done in silent mode, meaning that there will be no visible windows during the installation.
ADDLOCAL	This parameter indicated the type of the installation. No parameter added, installs only the launcher.

### Windows environment variable

The variable to be used is CLICKSHARE\_LAUNCHER\_CLIENT\_PATH. The value should be the path to the client software.

## 4.4 ClickShare Windows Certified driver

### About

The ClickShare Windows Certified driver is auto-installed when plugging in a Button in a Window PC.

This Windows driver automatically launches the executable on the Button.

Note that at least version **1.20.0** is required in order to support Buttons with firmware version 4.10 or higher. In case an older version is installed on your PC, start windows update *check for updates* with a button inserted into your PC. On Windows 7, 8 and 8.1 computers, the driver will have to be manually downloaded and installed.

## 4.5 ClickShare Desktop App

### About

With the ClickShare Desktop App installed on your computer you can enter a meeting room and get on the screen in a few seconds without the need to plug in a Button. The ClickShare Desktop App can be used in combination with a Button.

The ClickShare Desktop App connects to the meeting room screen in order to share your content. Presence detection technology is used to do so. The ClickShare Desktop App uses presence detection technology to determine which meeting room is closest to the user. Just click on your meeting room name. This means you will never have to enter IP addresses or scroll long lists of meeting rooms before being connected to your meeting room. Even more easy when using the PresentSense functionality. Just walk in a meeting room and click **Connect**.

When using Outlook as your main agenda, you get also an immediate overview of your next meetings. No need to search for the appointment or invite in Outlook. Just click **Join** to join your call.

## Installation

When the ClickShare Desktop App is not pre-deployed in your IT environment, you can download and install the software without administrator rights from [www.clickshare.app](http://www.clickshare.app). Admin rights are necessary to install the ClickShare Desktop App with calendar integration function. More info of the MSI installer can be found in “MSI installer of the ClickShare Desktop App”, page 47.

## 4.6 MSI installer of the ClickShare Desktop App



**CAUTION:** Installation can only be done with administrator rights.



Before running the ClickShare Desktop App installer, you will have to uninstall any previous installations of the ClickShare App on your computer.

### How to install

1. Download the MSI installer from [www.clickshare.app](http://www.clickshare.app).
2. Run the MSI installer by double clicking the downloaded file.

The installation wizard starts. Follow the instruction on the different windows.

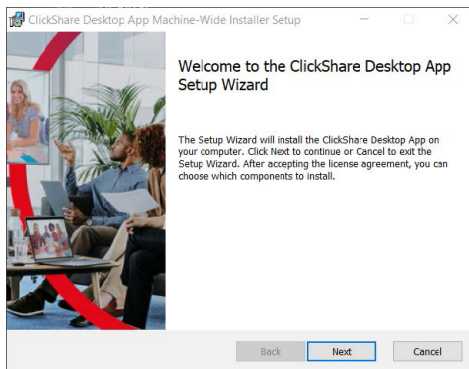

Image 4–4

3. Read the License Agreement and check the 'I accept the terms in the license agreement' checkbox to continue.

Click **Next**.

4. Enable the necessary components and click **Install**.

The ClickShare Desktop App and the selected features are now available for all users of your computer.



# C-5, C-10 Configurator

# 5

5.1	Accessing the Configurator .....	51
5.2	ClickShare Configuration Wizard .....	54
5.3	On-Screen ID information .....	56
5.4	Personalisation, Wallpaper .....	58
5.5	Personalisation, Personalized wallpaper .....	59
5.6	Manage configuration files .....	61
5.7	Display & Audio setup .....	62
5.8	Peripherals .....	62
5.9	Wi-Fi settings .....	63
5.10	Wi-Fi settings, Access Point settings .....	64
5.11	Wi-Fi settings, Wireless Client .....	66
5.12	Wi-Fi settings, Wireless Client, EAP-TLS .....	67
5.13	Wi-Fi settings, Wireless Client, EAP-TTLS .....	69
5.14	Wi-Fi settings, Wireless Client, PEAP .....	70
5.15	Wi-Fi settings, Wireless Client, WPA2-PSK .....	71
5.16	LAN settings .....	72
5.17	LAN Settings, Wired Authentication .....	74
5.18	LAN Settings, EAP-TLS security mode .....	75
5.19	LAN Settings, EAP-TTLS security mode .....	77
5.20	Services, Mobile devices .....	78
5.21	Service, PresentSense .....	80
5.22	Service, ClickShare API, remote control via API .....	81
5.23	Services, SNMP .....	81
5.24	Security, security level .....	82
5.25	Security, passwords .....	84
5.26	Security, HTTP Encryption .....	84
5.27	Status information Base Unit .....	86
5.28	Date & Time setup, manually .....	87
5.29	Date & Time setup, time server .....	89
5.30	Energy savers .....	89
5.31	Buttons .....	90
5.32	Buttons, External access point, mode EAP-TLS .....	91
5.33	Buttons, External access point, mode EAP-TTLS .....	93
5.34	Buttons, External access point, mode PEAP .....	94
5.35	Buttons, External access point, mode WPA2-PSK .....	95
5.36	Blackboard .....	96
5.37	XMS Cloud Integration .....	96
5.38	Firmware Update .....	98
5.39	Support & Updates, Troubleshoot, log settings .....	99
5.40	Troubleshooting, Erase all settings .....	100
5.41	Reset to factory defaults .....	100
5.42	Troubleshoot, diagnostics .....	101

## About configuration

The configuration of your device can be done in

- XMS cloud
- the local configurator

The configurator in XMS cloud will (in time) more elaborated than the local configurator. Therefore it preferred to configure your devices via XMS cloud. For more info see XMS documentation.

The next topics are describing the local configurator.



Within some menus the *Configurator* is indicated as *WebUI*. E.g. WebUI password, that is the password to enter the Configurator.

## 5.1 Accessing the Configurator

### Getting access to the Configurator

There are three ways to access the Configurator:

- Via the LAN
- Direct Ethernet connection between PC and Base Unit.
- Via the Base Unit's wireless network

When accessing the configurator for the first time, the ClickShare Configuration Wizard starts automatically.

This configuration wizard can be started at any moment to change your configuration instead of using the menus.

### To access the Configurator via the LAN

1. Open a browser.

 *Note:* Supported browsers are Microsoft Edge, Firefox, Google Chrome and Safari.

2. Browse to the IP address of your device.

 *Note:* If you do not know the IP address due to *Show network info* is disabled, connect via a direct connection or via a wireless connection to your device to discover the wired IP address.

A login screen appears.

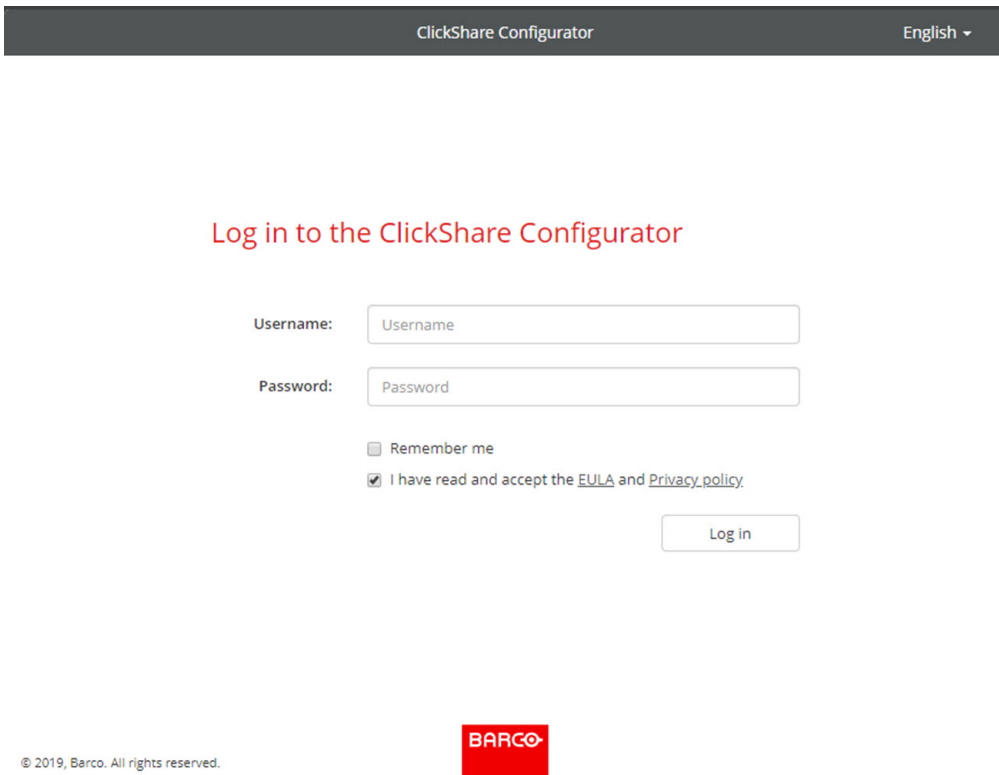

ClickShare Configurator English ▾

### Log in to the ClickShare Configurator

Username:

Password:

Remember me

I have read and accept the [EULA](#) and [Privacy policy](#).

© 2019, Barco. All rights reserved. 

Image 5–1 Login screen

3. To change the language of the Configurator, click on the drop down next to the current selected language and select the desired language.

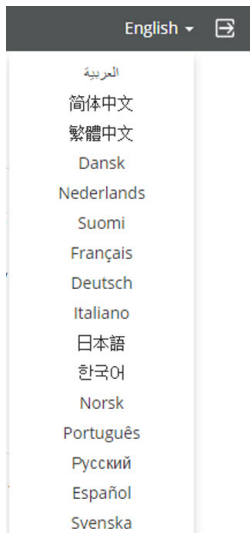

Image 5–2 Configurator languages

The following languages are possible:

- Arabic
- Simplified Chinese
- Traditional Chinese
- Danish
- Dutch
- English
- Finnish
- French
- German
- Italian
- Japanese
- Korean
- Norwegian
- Portuguese
- Russian
- Spanish
- Swedish

The Configurator language changes to the selected language.

4. Enter the user name 'admin' and the password, read and accept the EULA and the Privacy policy and click **OK**.

By default, the password is set to 'admin'.

Warning: It is strongly recommended to change the default password into a strong password on first use, to prevent that anyone else accessing the configurator can change the settings of the ClickShare Base Unit. See section “Security, passwords”.

The Configurator opens.



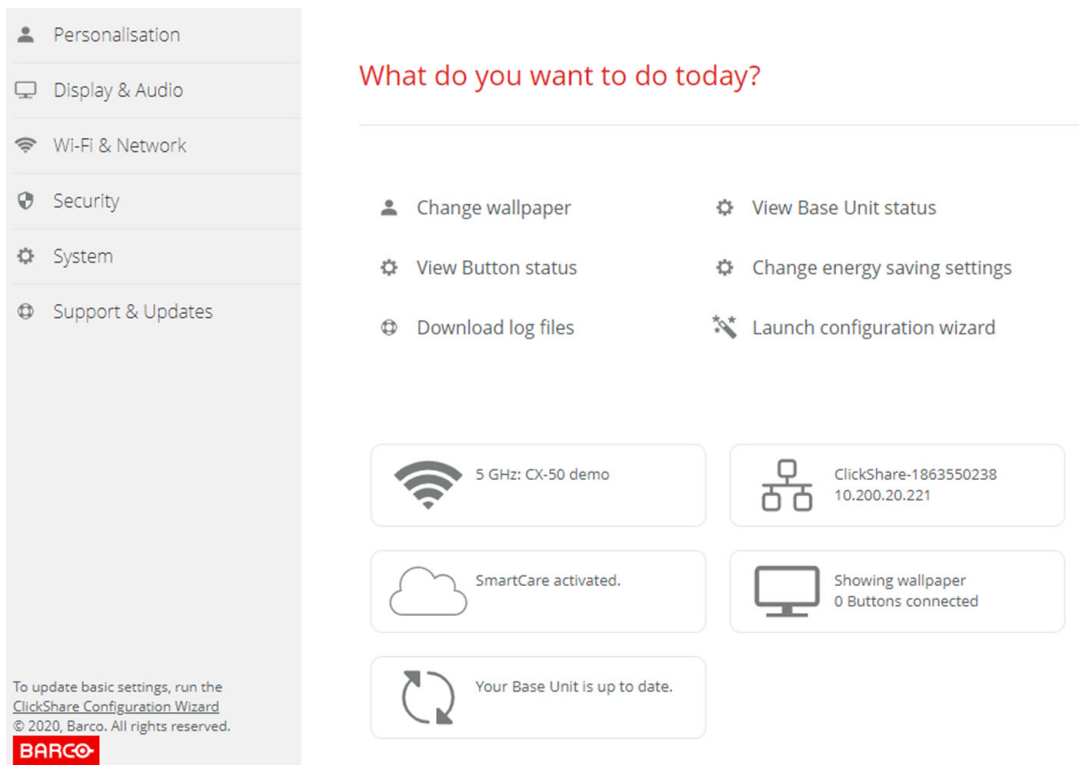

Image 5–3 Start screen

The language of the configurator can be changed on any page in the interface.

The screen is split up in 2 panes. Left pane with the selection buttons and a right pane to configure the selected function.

The startup screen itself shows:

- the wired IP address
- the wireless SSID
- the number of Buttons connected
- the system state
- the SmartCare state

Each of these boxes are also direct links to the described function.



If you cannot find the IP address (e.g. there is no screen available) you should connect to the Base Unit directly with your laptop via an Ethernet crossover cable and access the web interface using the fixed IP address 192.168.1.23. Make sure your own LAN adapter is set in the 192.168.1.x range.

### To access the Configurator via a direct connection.

1. Connect the Base Unit to your laptop using an Ethernet cable.
2. On your laptop, open a browser.



*Note:* Supported browsers are Microsoft Edge, Firefox and Safari.

3. Browse to <http://192.168.1.23>.

A login screen appears.

4. Enter the user name 'admin' and the password, read and accept the EULA and click **OK**.

By default the password is set to 'admin'.

The configurator opens. The wired IP address is given on the startup page.

## To access the Configurator via the Base Unit wireless network

1. On your laptop, connect to the Base Unit wireless network.  
The default SSID and password to connect to the Base Unit are respectively 'ClickShare-<serial base number>' and 'clickshare'.
2. On your laptop, open a browser.  
 **Note:** Supported browsers are Microsoft Edge, Firefox and Safari.
3. Browse to <http://192.168.2.1>.  
A login screen appears.
4. Enter the user name 'admin' and the password, read and accept the EULA and click **OK**.  
By default the password is set to 'admin'.  
The configurator opens. The wired IP address is given on the startup page.



Older laptops might not support the 5 GHz Frequency Band. If your Base Unit is set to that frequency range, those devices will not be able to connect to the Base Unit via the wireless network.

## Overview of functions

Group	Function
Personalization	On-Screen ID
	Wallpaper
	Configuration Files
Display & Audio	Display & Audio
	Peripherals
Wi-Fi & Network	Wi-Fi Settings
	LAN Settings
	Services
Security	Security levels
	Passwords
System	Base Unit Status
	Date & Time
	Energy Savers
	Buttons
	Blackboard
	XMS
Support & Updates	Firmware
	Troubleshoot

## 5.2 ClickShare Configuration Wizard



This procedure is equal with the onboarding procedure.

### About the configuration wizard

During the first start up of the Base Unit, the configuration wizard starts up automatically.

Or, you can start up the configuration wizard by clicking at the bottom left on **Configuration wizard** or on **Launch configuration wizard** on the dashboard page.

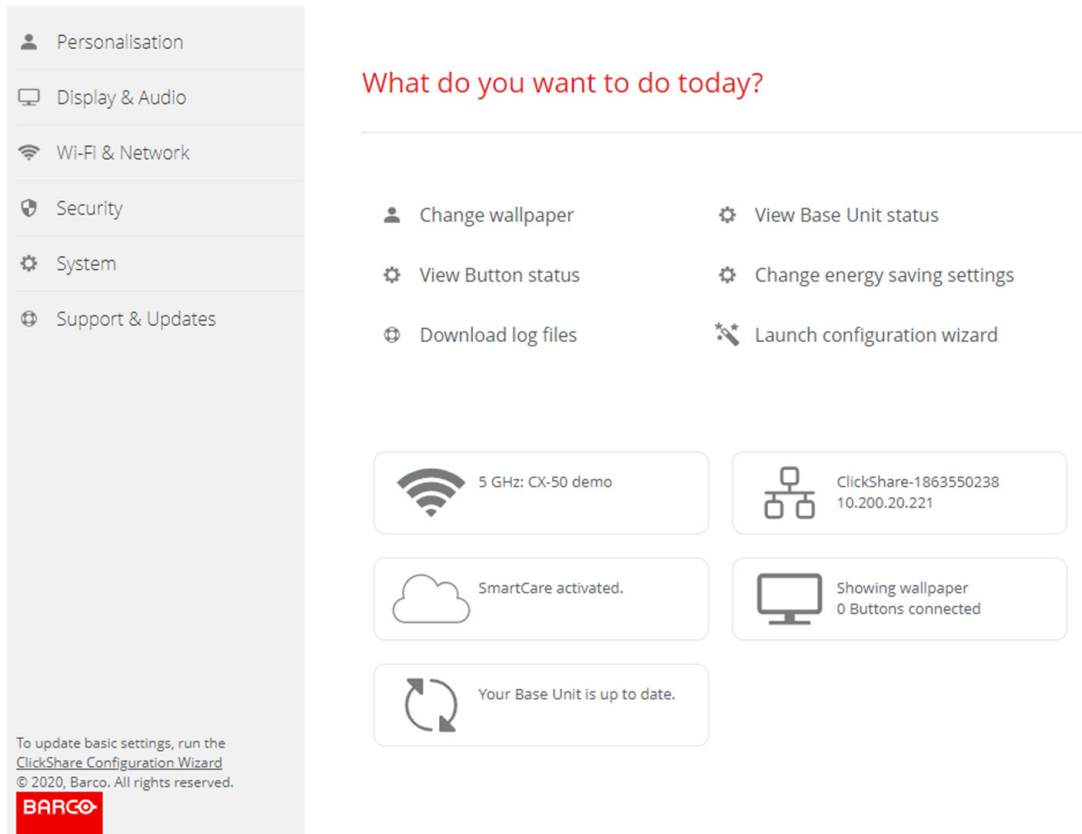

Image 5-4 Configuration Wizard start

All basic settings necessary to configure the Base Unit are covered by this configuration wizard. Once the configuration wizard is finished, the Base Unit is ready for use.

The welcome page indicates also the warranty start date. By default this period is 1 year and can be extended by registering your device.

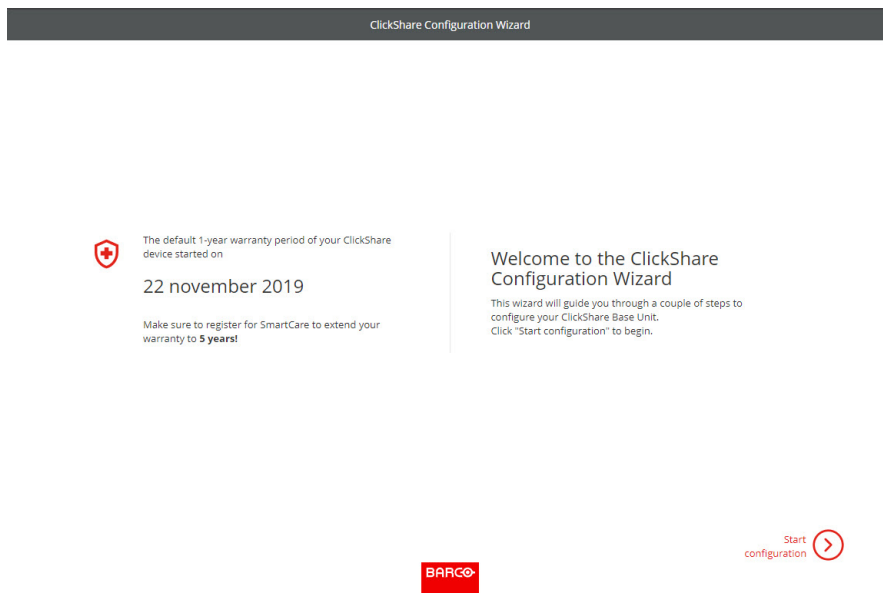

Image 5-5 Configuration welcome page

Click **Start configuration**.

Fill out the necessary items and click **Next** to continue.

To return to the previous step, click on **Back**.

For more information about a specific topic, see one of the following topics.

The ClickShare Configuration Wizard can be started at any time to change the configuration just by clicking on **ClickShare Configuration Wizard** at the left bottom of each screen or on *Launch configuration wizard* on the start page.

Firmware	Firmware update – automatically	See <a href="#">“Firmware Update”, page 98</a>
	Firmware update – manually	
Personalisation	Language on-screen text	See <a href="#">“On-Screen ID information”, page 56</a> .
	Meeting room name, location name and welcome message	See <a href="#">“On-Screen ID information”, page 56</a> .
System	Time zone, manual time setup	See <a href="#">“Date &amp; Time setup, manually”, page 87</a> .
	Use NTP	See <a href="#">“Date &amp; Time setup, time server”, page 89</a> .
Security	Level settings	See <a href="#">“Security, security level”, page 82</a> .
Password	ClickShare Configurator password	See <a href="#">“Security, passwords”, page 84</a> .
Network	Frequency band, channel Wi-Fi passphrase	See <a href="#">“Wi-Fi settings, Access Point settings”, page 64</a> .
SmartCare for ClickShare	Register your device to get the SmartCare package	See <a href="#">“Registration to XMS Cloud”, page 35</a> .

## 5.3 On-Screen ID information

### About device identification

The following items can be set:

- On-Screen language. Independent from the Configurator language.
- Meeting room name
- Location of the meeting room
- Welcome message to be displayed in the meeting room
- Show the network information
  - Checked: LAN information such as wired IP address is displayed. Also the Wi-Fi IP address and SSID are displayed.
  - Not checked: no LAN nor Wi-Fi information is displayed (default setup)
- Enable theater mode
  - Checked: the entire screen is used to share content. No status bar displayed anymore. The status bar pops up to show status changes, notifications, pin code etc. and fades out again. With touch screens a ‘tag’ enables you to bring up the status bar to start annotation and blackboarding.
  - Not-checked: Status bar remains on the screen.

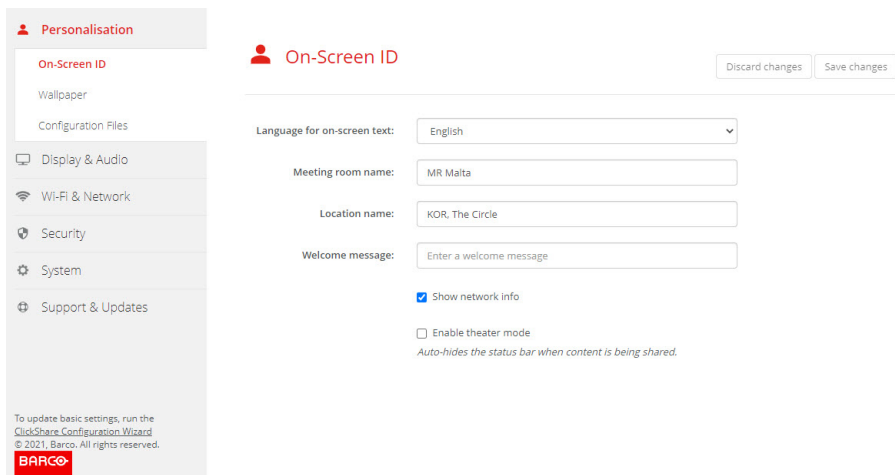

Image 5–6 On-Screen ID

## On Screen language selection

1. Log in to the Configurator.
2. Click *Personalisation* → *On-screen ID*.
3. Select the language of the on-screen text. Click on the drop down box next to *Language for on-screen text* and select the desired language.

The following languages are possible:

- Arabic
- Simplified Chinese
- Traditional Chinese
- Danish
- Dutch
- English
- Finnish
- French
- German
- Italian
- Japanese
- Korean
- Norwegian
- Portuguese
- Russian
- Spanish
- Swedish

## Meeting room name, location and welcome message

1. Log in to the Configurator.
2. Click *Personalisation* → *On-screen ID*.
3. Click in the input field next to *Meeting room name* and enter a name for the meeting room.  
This text is shown on the user's device when the Button is ready to share ("Ready to share on..."), on the central screen connected to the Base Unit and in the list of AirPlay receivers on the user's iOS device.
4. Click in the input field next to *Location name* and enter the location.
5. Click in the input field next to *Welcome message* and enter the desired message.

## 5.4 Personalisation, Wallpaper

### About wallpaper

When C-5, C-10 starts up, a background (wallpaper) is displayed. The display of this background wallpaper can be disabled.

By default two general ClickShare wallpapers are available. The possibility exists to upload personal backgrounds (wallpapers). The default wallpapers cannot be removed from the system.

### Wallpaper selection

1. Log in to the Configurator
2. Click *Personalisation* → *Wallpaper*.

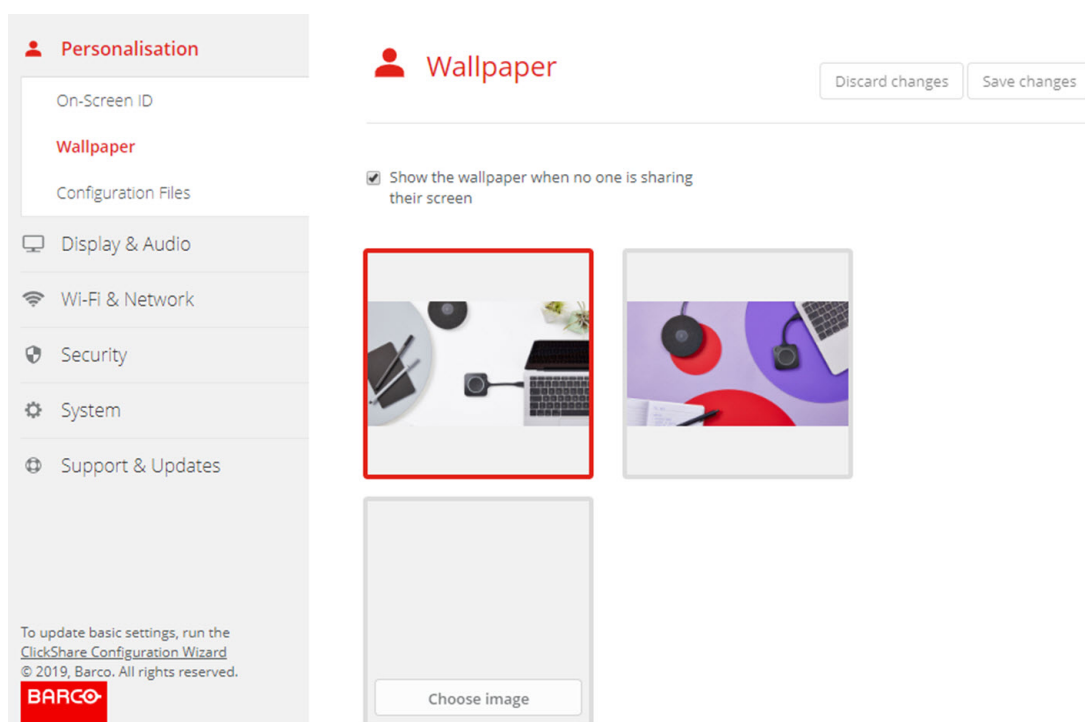

Image 5-7 Wallpaper selection

The *Wallpaper* selection pane is shown. The current selected wallpaper is shown with a red border.

3. Select one of the available wallpapers and click on **Save Changes**.

**Note:** By default two general Barco wallpapers are available. They are automatically resized to fit the aspect ratio of the screen.

The selected wallpaper is indicated with a red border.

The message **Successfully applied changes** appears on top of the wallpaper selection window.



You can also add a personal wallpaper, e.g. your company logo. For more information on adding a new wallpaper to the list, see [“Personalisation, Personalized wallpaper”](#), page 59.

### Download wallpaper

1. Hover with your mouse over the wallpaper to download and click on the download symbol on the upper right corner.



Image 5-8 Download wallpaper

The wallpaper is downloaded to your PC.

## Enable - disable Wallpaper

1. Within the Wallpaper pane, check the check box next to *Show the wallpaper when no one is sharing their screen*.

Checked: wallpaper will be displayed when no one is sharing content.

Not checked: no wallpaper will be displayed when no one is sharing content. The video output of the Base Unit is disabled when no content is shared. This feature is especially useful when the Base Unit is integrated in a room system such as a Cisco video conferencing system, Microsoft Teams room system or a Zoom room system.

## 5.5 Personalisation, Personalized wallpaper

### How to upload

1. Log in to the Configurator
2. Click *Personalisation* → *Wallpaper*.

The *Wallpaper* selection pane is shown. The current selected wallpaper is shown with a red border.

3. Hoover your mouse over the free place and click on **Choose image**.

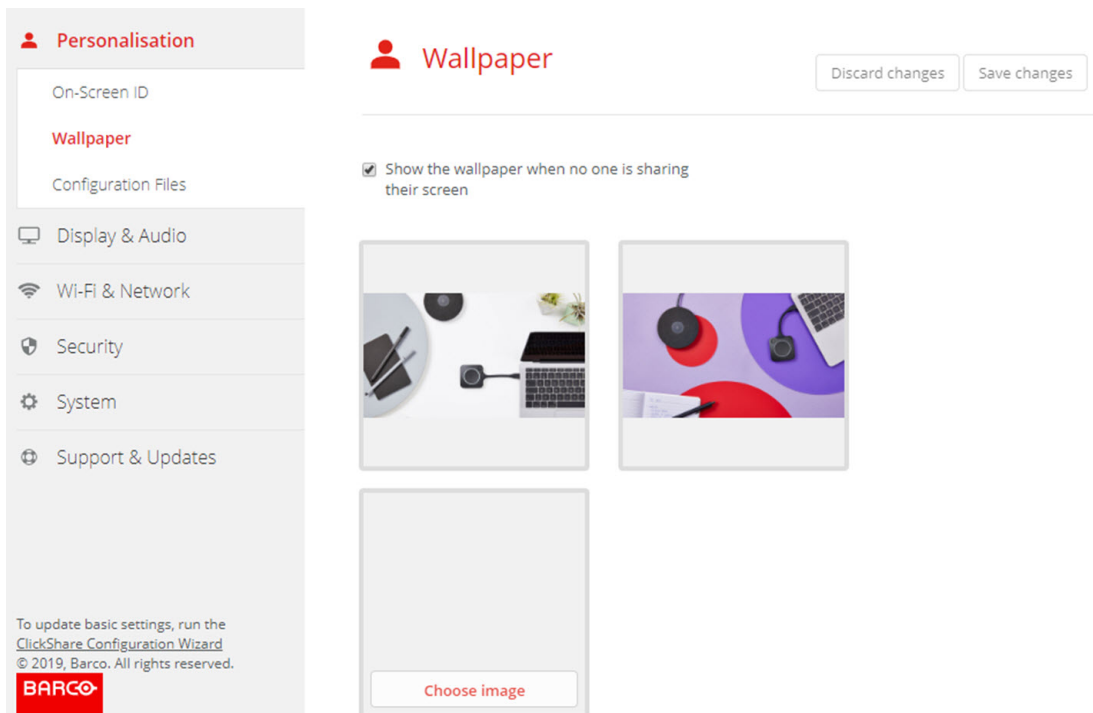

Image 5-9 Personalized wallpaper selection

A browser window opens.

4. Browse for the desired image, click Open to load the image.

The content of the file is checked and when valid (format and size), the file is uploaded. The new wallpaper gets a red border.

5. Click on **Save changes** to apply the personalized wallpaper

The message **Successfully applied changes** is displayed on top of the page.

## Change personalized image

1. Click *Personalisation* → *Wallpaper*.
2. Hoover your mouse over the current personalized image and click **Change image**.

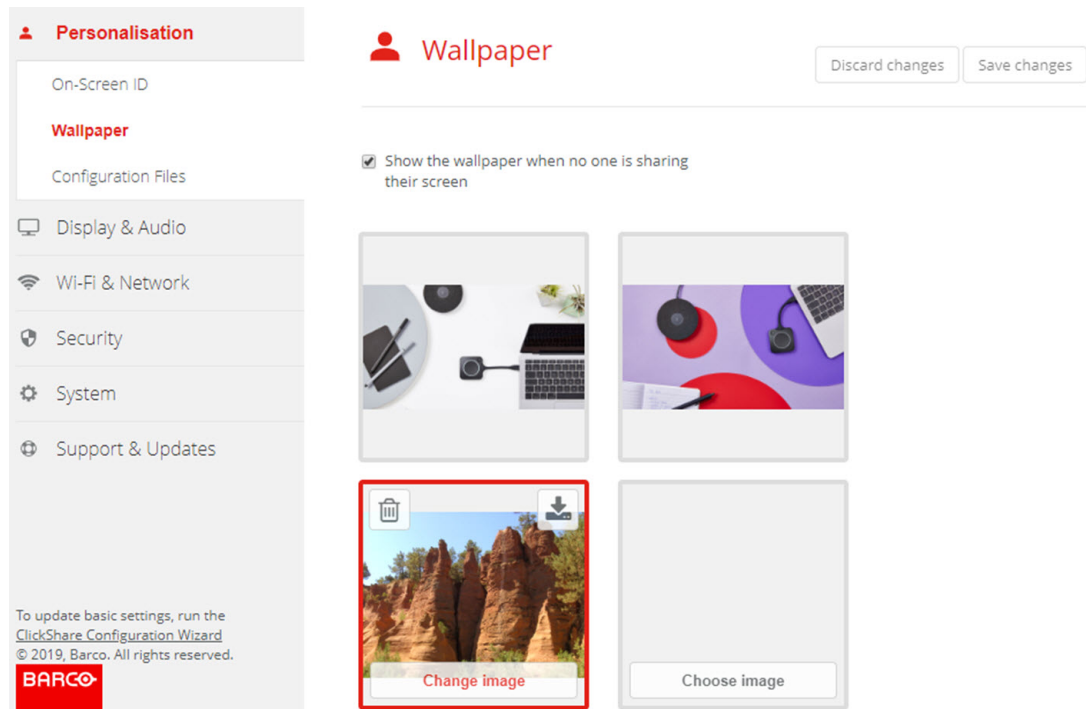

Image 5–10 Change image

3. Browse for the desired image, click Open to load the image.

The content of the file is checked and when valid (format and size), the file is uploaded. The new wallpaper gets a red border.

4. Click on **Save changes** to apply the personalized wallpaper and replace the previous file.

The message **Successfully applied changes** is displayed on top of the page.

## Remove personalized wallpaper

1. Hoover your mouse over the current image and click on the trash bin to remove the image.

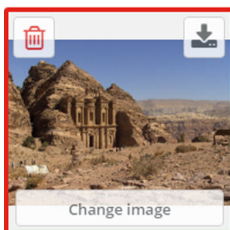

Image 5–11 Remove wallpaper

The personalized wallpaper is removed and the default wall paper is activated.



## 5.6 Manage configuration files

### About Manage configuration files

A full backup can be downloaded but cannot be used to duplicate configuration settings to other Base Units. Therefore, it is possible to download a Portable version. This portable version can be uploaded via the upload configuration button on other Base Units (same type). Via the same button, the full backup can be uploaded on the original Base Unit.

A portable backup contains:

- Wallpapers
- Wallpapers settings
- Logging settings
- All display settings
- OSD language
- Location
- Welcome message
- Wi-Fi channel
- Wi-Fi frequency

### To manage the configuration files

1. Log in to the *Configurator*.
2. Click *Personalisation* → *Configuration Files*.

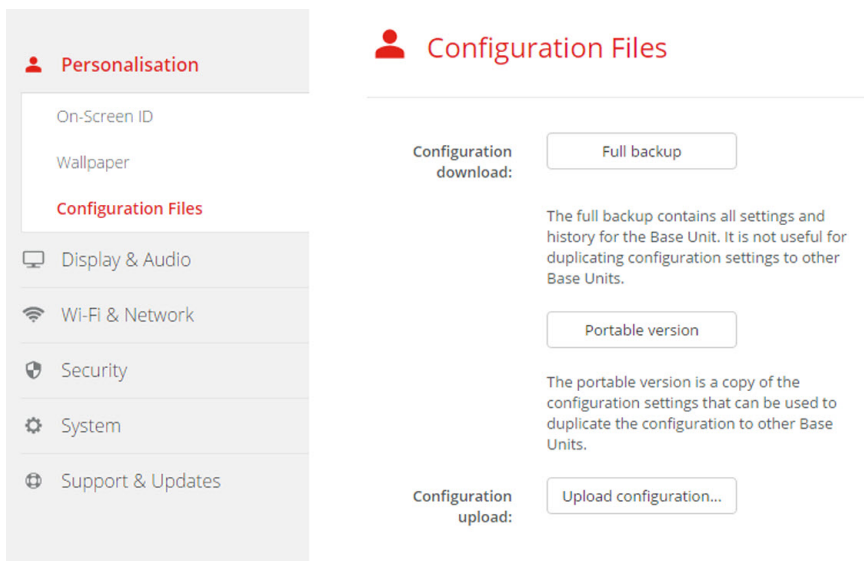

Image 5–12 Configuration files

3. To download a full backup, click on **Full Backup**.

An xml file, containing all information and history will be downloaded. This file can be reused on the same Base Unit only.

4. To download a portable version, click on **Portable Version**.

An xml file, containing portable information to duplicate settings on another Base Unit.

5. To upload a configuration, click on **Upload Configuration**.

A browser window opens. Navigate to the upload file (xml file) and click **Open** to upload.

A full backup can be uploaded on the Base Unit where the backup was created and a portable version can be uploaded on any other Base Unit of the same model.



When uploading a config file, the history of software updates and paired Buttons is lost. Paired Buttons will however remain functional if the Base Unit has not changed from SSID or wireless password.

## 5.7 Display & Audio setup

### Resolution

The output resolution to the display is set on Auto. That means that the C-5, C-10 output resolution is automatically adapted to the resolution of the display. For HDMI displays, a hot plug detection is available.

When a display is connected to the output the Model & Vendor or indicated.

When no display is connected, the indication *Not Connected* is displayed next to *Display Output*.

### CEC

Consumer Electronics Control (CEC) is a feature of HDMI designed to allow users to command and control devices connected through HDMI by using only one remote control.

To enable CEC, check the check box before *Enable CEC*.

### Audio

Enable or disable audio output.

Check the check box in front of Enable audio to enable audio output.

### Screen saver setup

1. Log in to the *Configurator*.

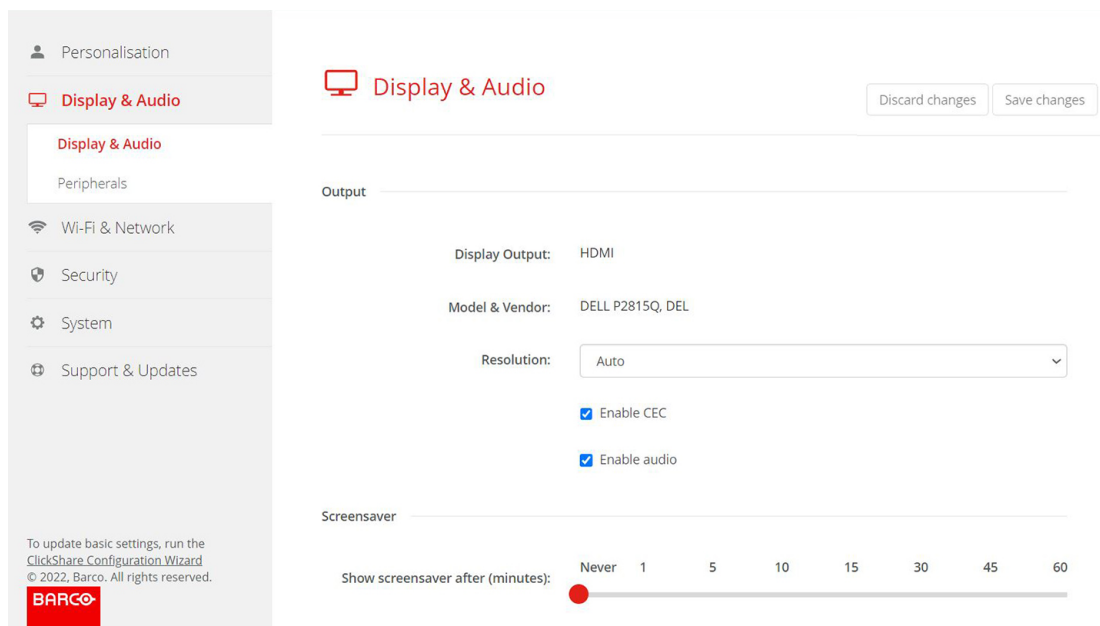

Image 5–13

2. Click *Display & Audio* → *Display & Audio*.
3. To activate the screen saver, drag the slider bar to the left or to the right until the desired delay time is reached.  
When the slider is set completely to the left, the screen saver will never be activated.
4. Click **Save changes**.

## 5.8 Peripherals

### Overview

Information about the speaker is given in the Peripherals pane.

## How to get

1. Log in to the *Configurator*.
2. Click *Display & Audio* → *Peripherals*.

Information about the speaker is given.

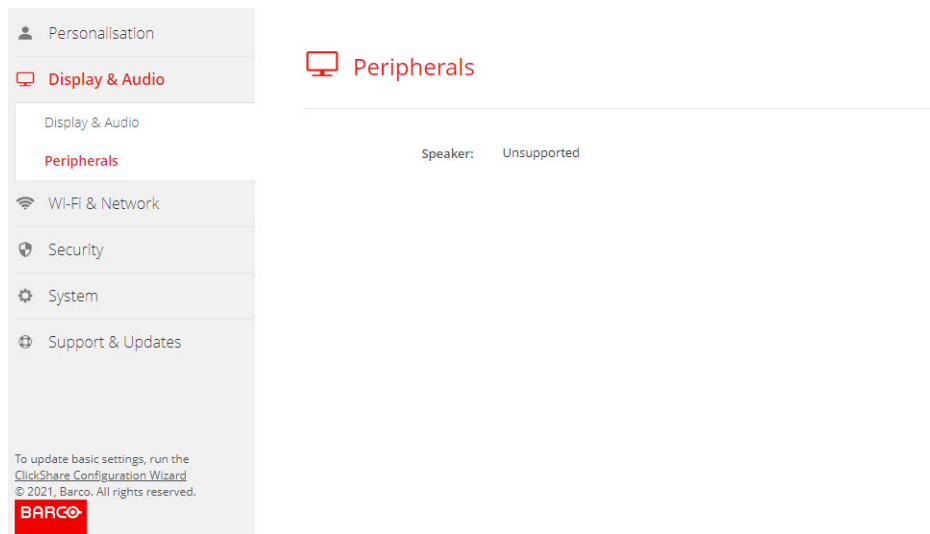

Image 5–14

## 5.9 Wi-Fi settings



**WARNING:** It is not allowed to operate the Base Unit outside its intended geographical region.

### About

The operational mode of the Wi-Fi setting can be set in 3 different modes:

- Access point
- Wireless client
- Off

### Change operational mode

1. Log in to the *Configurator*.
2. Click *Wi-Fi & Network* → *Wi-Fi Settings*.

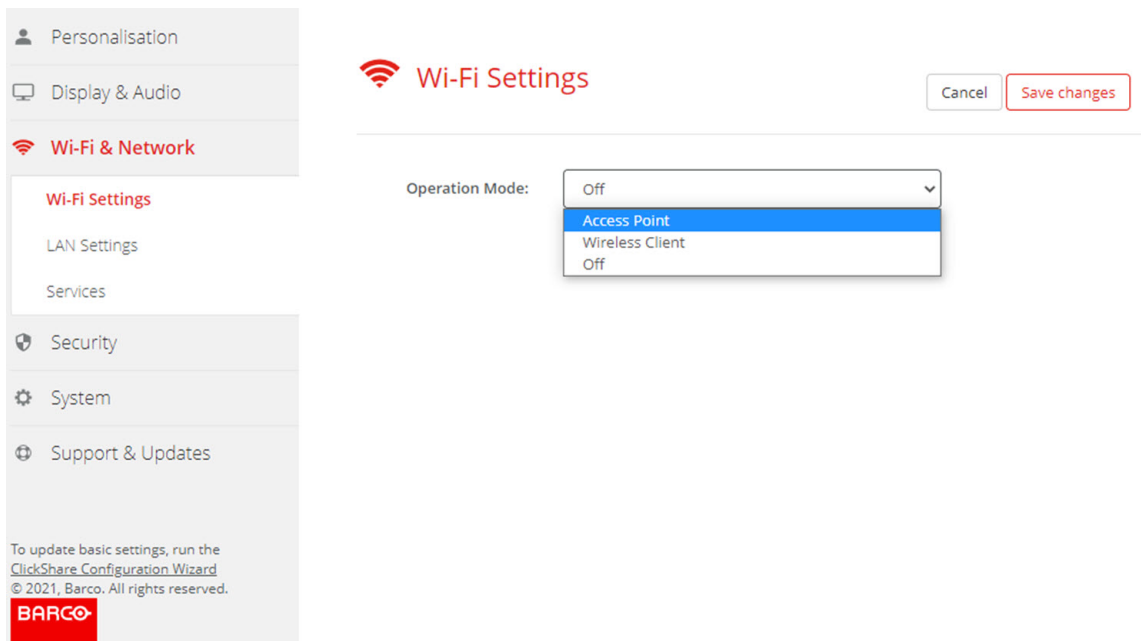

Image 5–15 Wi-Fi settings

3. Select the operational mode by clicking on the drop down and selecting the desired option.

The following options are possible.

- Access point
- Wireless client
- Off

4. To change the Access Point settings, select Access Point.

For more detailed information, see [“Wi-Fi settings, Access Point settings”](#), page 64

5. To change the Wireless Client Settings, select Wireless Client.

For more detailed information, see [“Wi-Fi settings, Wireless Client”](#), page 66.

## 5.10 Wi-Fi settings, Access Point settings

### How to change

1. Check the check box next to *Enable*.

*Checked*: access point settings are enabled. All current settings can be changed.

*Unchecked*: access point settings are disabled.

2. If desired, enter a new Wi-Fi passphrase and confirm this Wi-Fi passphrase.

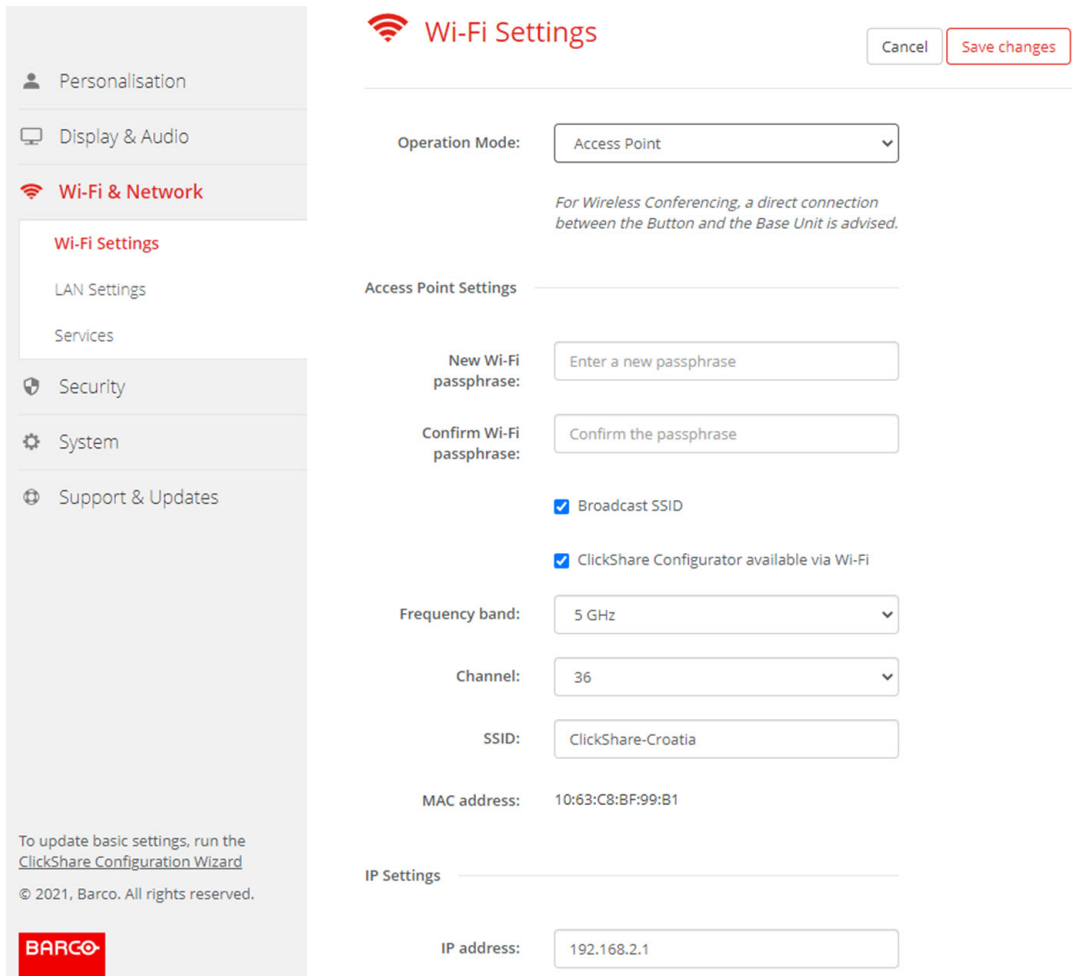

Image 5–16 Wi-Fi settings, access point settings

3. Enter a public name (SSID) for the wireless network.  
The default SSID is *ClickShare- $\langle$ serial number Base Unit $\rangle$* .
4. If you want to broadcast this SSID, check the checkbox before *Enable SSID broadcast*.

### About frequency band & channel selection

In an ideal setup, overlapping channels should not be used for two ClickShare Base Units within range of each other. As the channels in the 2.4 GHz band overlap with each other, best practice is to use channels 1, 6 and 11 on a single floor. On floors above and below, the channel pattern will be shifted to avoid overlap between floors, e.g. by placing channel 6 at the center of the illustrated pattern.

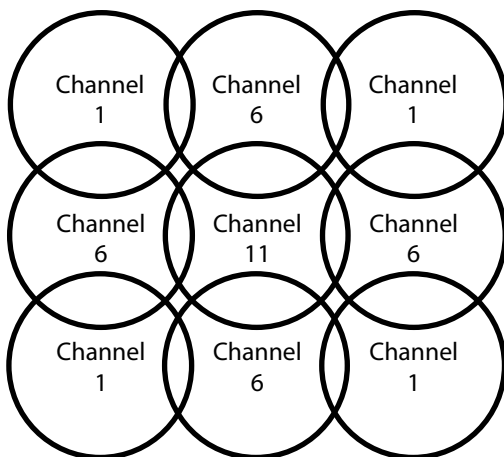

Image 5–17

The 5 GHz channels do not overlap with each other and are less used by non-Wi-Fi devices than the 2.4 GHz channels. Moreover, 5 GHz signals are more rapidly damped than 2.4 GHz signals. Therefore, the use of a 5 GHz channel is recommended. This will limit the impact of a ClickShare system on other installed ClickShare units and on other WLAN users.

## Frequency band & channel selection

1. Select the wireless connection channel by clicking on the drop down box and selecting the desired channel.

The channels available in the list vary according to the regional version of your Base Unit. Re-pairing the Buttons is not required when changing the frequency band or wireless connection channel.

Ideally, the ClickShare channel is selected after conducting a wireless site survey. A site survey maps out the sources of interference and the active RF systems. There are several Wi-Fi survey tools available on the market. Based on the results from a site survey, the least occupied channel can be found and selected for each meeting room.

2. Select the wireless connection frequency band: 2.4 GHz or 5 GHz by clicking on the drop down box and selecting the correct band.

Below the channel selection pane, an indication is given of the available bandwidth of the current channel. To see if sufficient bandwidth is available in a different channel, select the channel in the drop down and save the changes. The page will reload with the new settings and an indication of the channel fit will be given after approximately 1 minute. There is no need to reload the page to see the result.

The channels available in the list vary according to the regional version of your Base Unit. Re-pairing the Buttons is not required when changing the frequency band or wireless connection channel.

When Intense use, change to another Wi-Fi channel is displayed, change to another channel. The page will reload after approximately 1 minute.

## ClickShare Configurator access via Wi-Fi

1. To allow access to the Configurator via Wi-Fi, check the check box in front of *WebUI available via Wi-Fi*.

Checked: Configurator accessible via Wi-Fi.

Not checked: access to the configurator via Wi-Fi is blocked.

## IP address & subnet mask

1. To change the IP address or subnet mask, click in the input field and enter the 4 octets of the new IP address or subnet mask.

 *Note:* This must NOT be 0.0.0.0 for static IP-Address assignment.

## Wireless Client Settings

For more info, see [“Wi-Fi settings, Wireless Client”](#), page 66.

# 5.11 Wi-Fi settings, Wireless Client

## Introduction

Wireless Client mode allows to connect the Base Unit to a network over Wi-Fi instead of via the Ethernet interface. It brings identical functionality as a wired network connection; complete network integration, auto-update functionality and central management in XMS. It offers increased flexibility in the placement of the Base Unit as a network cable drop is no longer required on the installation location.

Note that when Wireless Client mode is enabled, the Base Unit Wi-Fi is occupied and can no longer be used for direct connections, either from the ClickShare Button, the ClickShare apps or from Airplay or Google Cast and Miracast. This means that these connections need to happen over the corporate network. As a consequence, when setting up Wireless Client mode, the Buttons are auto-configured to connect to the same network as the Base Unit. This setting however can be manually changed in the Buttons tab in the System menu.



For Wireless Conferencing, a direct connection between the Button and the Base Unit is advised.

## How to activate Wireless Client

1. Log in to the *Configurator*.
2. Click *Wi-Fi & Network* → *Wi-Fi Settings*.
3. Click **Edit settings**.
4. Click on the drop down box next to *Operational Mode* and select *Wireless Client*.

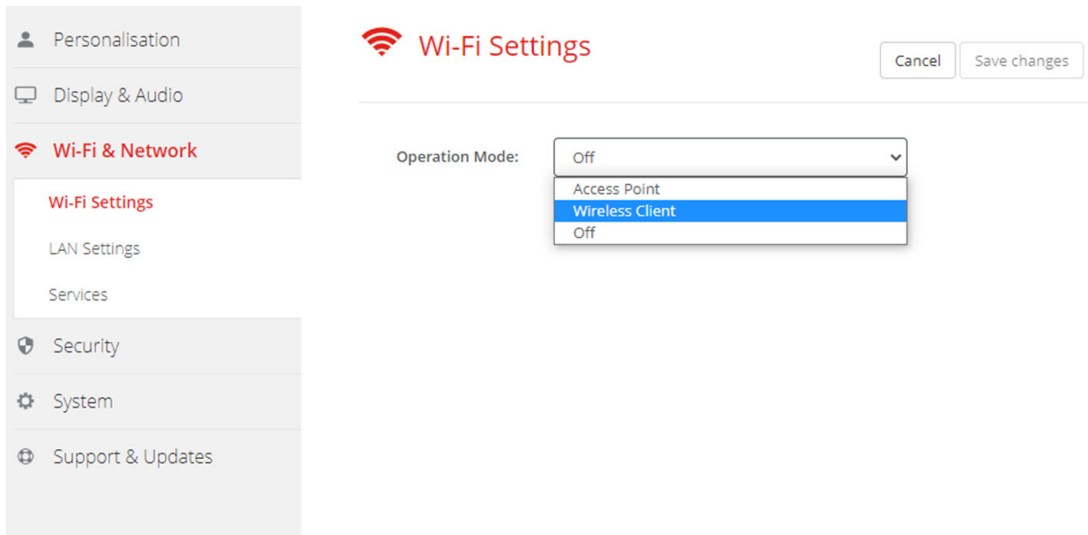

Image 5–18 Wi-Fi settings, Wireless Client

## 5.12 Wi-Fi settings, Wireless Client, EAP-TLS

### About EAP-TLS

EAP-TLS (Transport Layer Security) is an EAP method based on certificates which allows mutual authentication between client and server. It requires a PKI (Public Key Infrastructure) to distribute server and client certificates. For some organizations this might be too big of a hurdle, for those cases EAP-TTLS and PEAP provide good alternatives. Even though a X.509 client certificate is not strictly required by the standard it is mandatory in most implementations including for ClickShare. When implemented using client certificates, EAP-TLS is considered one of the most secure EAP methods. The only minor disadvantage, compared to PEAP and EAP-TTLS, is that the user identity is transmitted in the clear before the actual TLS handshake is performed. EAP-TLS is supported via SCEP, INDES or manual certificate upload.

### How to start up for EAP-TLS

1. Select *EAP-TLS* from the drop down list next to *Authentication Mode*.

Authentication Mode: EAP-TLS

Corporate SSID:

Domain:

Identity:

Provide certificate: Manually provide Client & CA certificates

Upload client certificate: **Bestand kiezen** Geen bestand gekozen  
 Allowed file formats: .pfx (PKCS#12), .p12 (Base64 encoded DER).  
 File should at least include the client certificate and corresponding private key.

Client certificate Password:

Upload CA certificate: **Bestand kiezen** Geen bestand gekozen  
 Allowed file formats: .pem, .cer, .crt, .p7b (Base64 encoded DER).  
 File should at least contain the root CA certificate for your domain.

Method: Automatic (DHCP)

IP address:

Subnet mask:

Default gateway:

DNS servers:

To update basic settings, run the [ClickShare Configuration Wizard](#)

© 2021, Barco. All rights reserved.

**BARCO**

Image 5–19 Wi-Fi Settings, Wireless Client, EAP-TLS

2. Fill out a *Corporate SSID*.  
The SSID of your corporate wireless infrastructure to which the ClickShare Buttons will connect.
3. Fill out the *Domain* and *Identity*.
4. Select the certification method. Click on the drop down box and select the desired method.
  - Manually provide Client & CA certificates
  - Auto enrollment via SCEP

## Manually providing certificates

1. Upload client certificate. Click on Choose file and browse to the desired file.  
 Allowed file formats:
  - .pfx (PKCS#12)
  - .p12 (Base64 encoded DER)
 The should at least include the client certificate and corresponding private key.
2. Enter the Client certificate Password.
3. Upload CA certificate. Click on Choose file and browse to the desired file.  
 The following formats are allowed:
  - .pem
  - .cer
  - .crt
  - .pb7 (Base64 encoded DER)



File should at least contain the root CA certificate for your domain.

#### 4. Save Changes

### Using Auto enrollment

The Simple Certificate Enrolment Protocol (SCEP) is a protocol which enables issuing and revoking of certificates in a scalable way. SCEP support is included to allow a quicker and smoother integration of the ClickShare Base Unit and Buttons into the corporate network.

Up until Base Unit firmware version 02.11.01 the SCEP implementation was specifically targeted at the Network Device enrollment Service (NDES) which is part of Windows Server. From Base Unit firmware version 02.12.00 and later we support both NDES and standard SCEP.

#### NDES requires the following parameters:

**SCEP Server:** This is the IP or hostname of the Windows Server in your network running the NDES service. Only http is allowed. E.g.: http://myserver or http://10.192.5.1

**SCEP username:** This is a user in your Active Directory which has the required permission to access the NDES service and request the challenge password. To be sure of this, the user should be part of the CA Administrators group (in case of a stand-alone CA) or have enrol permissions on the configured certificate templates.

**SCEP Password:** The corresponding password for the SCEP username that you are using to authenticate on service.

**Common Name:** The identity you want to link to the certificate.

Image 5–20 Wi-Fi Settings, Wireless Client, EAP-TLS, NDES

#### SCEP requires the following parameters:

**SCEP Server:** This is the IP or hostname of Server the server running the SCEP service with the port and suffix appended. Only http is allowed. E.g.: http://myserver:8080/scep or http://10.192.5.1/test

**SCEP Challenge:** The corresponding SCEP challenge password.

**Common Name:** The identity you want to link to the certificate.

Image 5–21 Wi-Fi Settings, Wireless Client, EAP-TLS, SCEP

## 5.13 Wi-Fi settings, Wireless Client, EAP-TTLS

### About EAP-TTLS

EAP-TTLS (Tunneled Transport Layer Security) is an EAP implementation by Juniper networks. It is designed to provide authentication that is as strong as EAP-TLS, but it does not require each user to be issued a certificate. Instead, only the authentication servers are issued certificates. User authentication is performed by password, but the password credentials are transported in a securely encrypted tunnel established based upon the server certificates.

User authentication is performed against the same security database that is already in use on the corporate LAN: for example, SQL or LDAP databases, or token systems. Since EAP-TTLS is usually implemented in

corporate environments without a client certificate we have not included support for this. If you prefer using client certificates per user we suggest using EAP-TLS.

## How to start up for EAP-TTLS

1. Select *EAP-TTLS* from the drop down list next to *Authentication Mode*.

The screenshot displays the configuration interface for a wireless client. On the left is a navigation sidebar with categories: Personalisation, Display & Audio, Wi-Fi & Network (selected), LAN Settings, Services, Security, System, and Support & Updates. The main content area shows the following settings:

- Authentication Mode:** A dropdown menu set to "EAP-TTLS".
- Corporate SSID:** An empty text input field.
- Domain:** An empty text input field.
- Identity:** An empty text input field.
- Anonymous Identity:** An empty text input field. Below it is a note: "Leave this field empty in order not to use Anonymous Identity during the authentication process."
- Password:** An empty text input field.
- Upload CA certificate (optional):** A button labeled "Bestand kiezen" (Choose file) with the text "Geen bestand gekozen" (No file selected). Below the button, it states: "Allowed file formats: .pem, .cer, .crt, .p7b (Base64 encoded DER). File should at least contain the root CA certificate for your domain."
- Method:** A dropdown menu set to "Automatic (DHCP)".
- IP address:** A disabled text input field.
- Subnet mask:** A disabled text input field.
- Default gateway:** A disabled text input field.
- DNS servers:** A disabled text input field.

At the bottom of the sidebar, there is a note: "To update basic settings, run the [ClickShare Configuration Wizard](#)" and a copyright notice: "© 2021, Barco. All rights reserved." The Barco logo is also present at the bottom left of the sidebar.

Image 5–22 Wi-Fi Settings, Wireless Client, EAP-TTLS

## 5.14 Wi-Fi settings, Wireless Client, PEAP

### About PEAP

PEAP (Protected Extensible Authentication Protocol) is an EAP implementation co-developed by Cisco Systems, Microsoft and RSA Security. It sets up a secure TLS tunnel using the servers CA certificate after which actual user authentication takes place within the tunnel. This way of working enables it to use the security of TLS while authenticating the user but without the need for a PKI.

The standard does not mandate which method is to be used to authenticate within the tunnel. But in this application note, with regard to PEAP, we are referring to PEAPv0 with EAP-MSCHAPv2 as the inner authentication method. This is one of the two certified PEAP implementations in the WPA and WPA2 standards – and by far the most common and widespread implementation of PEAP.

### How to start up for PEAP

1. Select *PEAP* from the drop down list next to *Authentication Mode*.

Image 5–23 Wi-Fi Settings, Wireless Client, PEAP

2. Fill out a *Corporate SSID*.  
The SSID of your corporate wireless infrastructure to which the ClickShare Buttons will connect.
3. Fill out the *Domain* and *Identity*.
4. Enter a *Password*.
5. Upload CA certificate. Click on Choose file and browse to the desired file.  
The following formats are allowed:
  - .pem
  - .cer
  - .crt
  - .pb7 (Base64 encoded DER)
File should at least contain the root CA certificate for your domain.
6. Click **Save Changes** to save the settings.

## 5.15 Wi-Fi settings, Wireless Client, WPA2-PSK

### About WPA2-PSK

WPA2-PSK does not distinguish between individual users, there is 1 password (PSK – Pre-Shared Key) for all clients connecting to the wireless infrastructure. This makes setup very straightforward. Once connected, all data transmitted between client and AP (access point) is encrypted using a 256 bit key.

### How to start up for WPA2-PSK

1. Select *WPA2–PSK* from the drop down list next to *Authentication Mode*.

Authentication Mode: WPA2-PSK

Corporate SSID:

Passphrase:

Method: Automatic (DHCP)

IP address:

Subnet mask:

Default gateway:

DNS servers:

Image 5–24 Wi-Fi Settings, Wireless Client, WPA-PSK

**2.** Fill out a *Corporate SSID*.

The SSID of your corporate wireless infrastructure to which the ClickShare Buttons will connect.

**3.** Fill out Passphrase.

The key used in WPA2-PSK to authenticate onto the wireless infrastructure. This can be a string of 64 hexadecimal digits or a passphrase of 8 to 63 printable ASCII characters.

**4.** Click **Save changes**.

## 5.16 LAN settings

### About LAN network settings

A network connection can be configured through DHCP or by manually entering a fixed IP address.



#### DHCP

Dynamic host configuration protocol. DHCP is a communications protocol that lets network administrators manage centrally and automate the assignment of IP addresses in an organization's network. Using the Internet Protocol, each machine that can connect to the Internet needs a unique IP address. When an organization sets up its computer users with a connection to the Internet, an IP address must be assigned to each machine. Without DHCP, the IP address must be entered manually at each computer and, if computers move to another location in another part of the network, a new IP address must be entered. DHCP lets a network administrator supervise and distribute IP addresses from a central point and automatically sends a new IP address when a computer is plugged into a different place in the network.

### Hostname & method

- 1.** Log in to the *Configurator*.
- 2.** Click *Wi-Fi & Network* → *LAN Settings*.

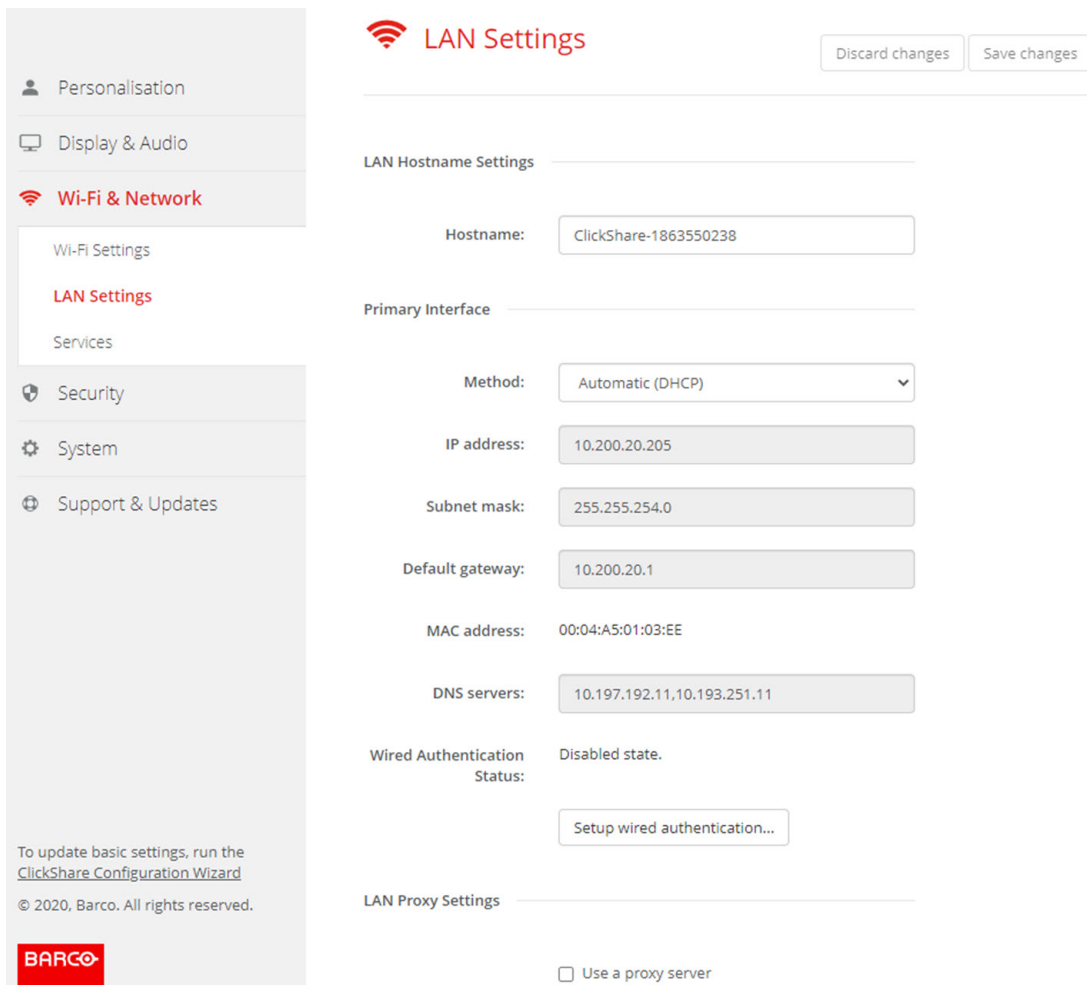



Image 5–25 LAN settings

3. Click in the input field next to *Hostname* and enter a host name for the Base Unit.  
The default host name is *ClickShare-  
<serial number Base Unit>*.
4. To select the method, click on the drop down box next to *Method* and select the *Automatic (DHCP)* or *Manual*.  
When *Automatic (DHCP)* is selected, the IP address, subnet mask and default gateway fields are grayed out but the currently used settings are filled out.
5. Click **Save changes** to apply the settings.

### Manual (fixed) IP address

1. Click on the drop down box next to *Method* and select *Manual*.  
The IP address, subnet and gateway input fields are activated.
2. Click in the input field of the *IP address* and fill out the 4 octets.
  -  **Note:** An address contains 4 octets with a maximum value of 255.  
This must NOT be 0.0.0.0 for static IP-Address assignment
3. Click in the *Subnet mask* input fields and fill out the 4 octets as appropriate for the local subnet.
4. Click in the *Default Gateway* input fields and fill out the 4 octets. Set the Default-Gateway to the IP-Address of the router (MUST be on the local subnet!).
  -  **Note:** This must NOT be 0.0.0.0.  
If there is no router on the local subnet then just set this field to any IP-Address on the subnet.

5. Click in the DNS Servers input field and fill out the preferred DNS servers (maximum 5) in a comma separated list.
6. Click **Save changes** to apply the settings.



Do not use IP address 192.168.2.x for a Subnet mask 255.255.255.0 and IP address 192.168.x.x for a Subnet mask 255.255.0.0

## Use a proxy server

This setting is important for the auto-update feature of the Base Unit, which require internet access.

1. Check the check box next to Use a proxy server.

Use a proxy server

Server address:

Server port (optional):

User name (optional):

Password (optional):

Image 5–26 Proxy settings

The proxy settings become available.

2. Enter the proxy server address. Enter the IP address or hostname.  
Some proxy servers need a port number, user name and password, for others is this optional.
3. Optionally, enter the used server port.
4. Optionally, enter the user name.
5. Optionally, enter the password.
6. Click **Save changes** to apply the settings.

## 5.17 LAN Settings, Wired Authentication

### How to setup

1. Click on **Setup wired authentication...**

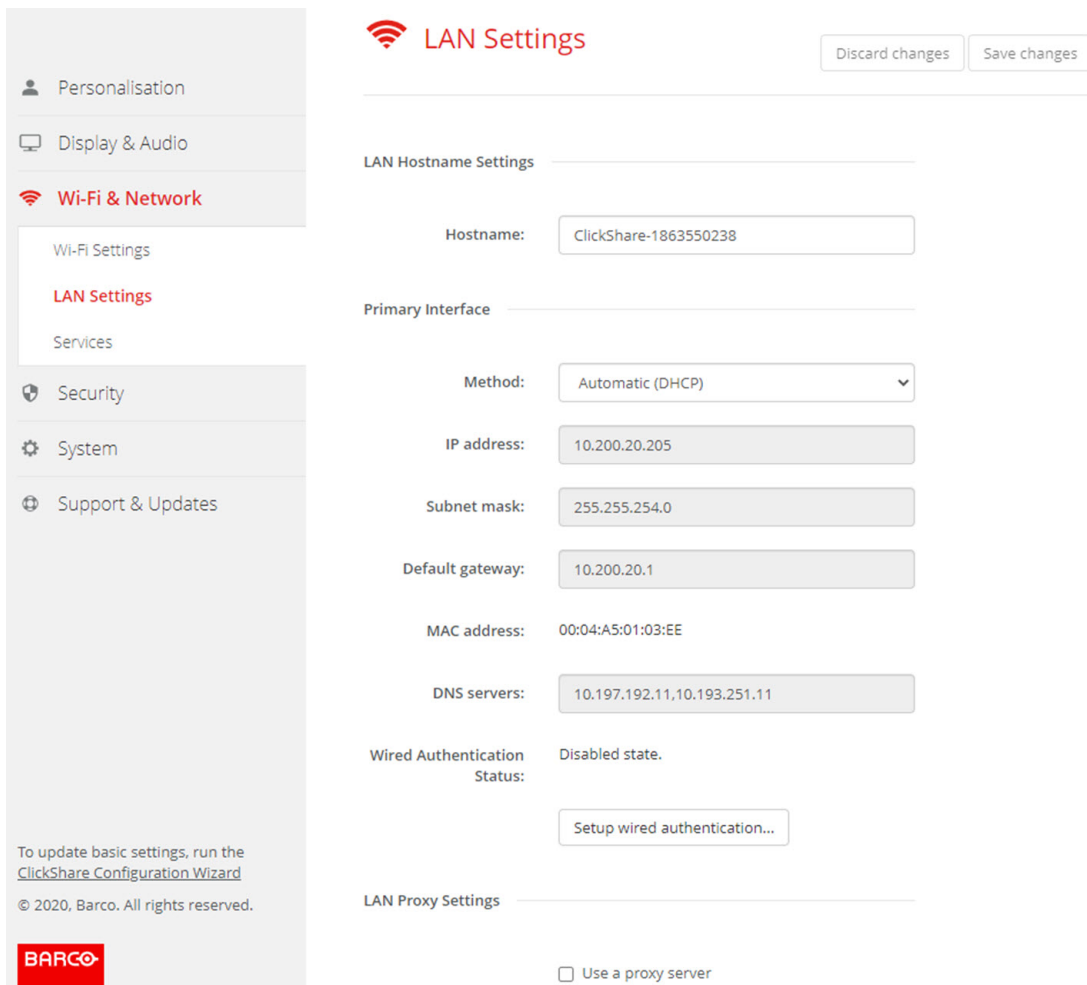

Image 5–27 Wired authentication

The setup wizard starts.

2. Select the authentication method. Click on the drop down and select the desired method.

The following methods are available:

- No authentication: no authentication mechanism will be applied to the wired interface.
- EAP-TLS
- EAP-TTLS
- PEAP

## 5.18 LAN Settings, EAP-TLS security mode

### About EAP-TLS

EAP-TLS (Transport Layer Security) is an EAP method based on certificates which allows mutual authentication between client and server. It requires a PKI (Public Key Infrastructure) to distribute server and client certificates. For some organizations this might be too big of a hurdle, for those cases EAP-TTLS and PEAP provide good alternatives. Even though a X.509 client certificate is not strictly required by the standard it is mandatory in most implementations including for ClickShare. When implemented using client certificates, EAP-TLS is considered one of the most secure EAP methods. The only minor disadvantage, compared to PEAP and EAP-TTLS, is that the user identity is transmitted in the clear before the actual TLS handshake is performed. EAP-TLS is supported via SCEP or manual certificate upload.

### How to setup EAP-TLS

1. Select Authentication Mode *EAP-TLS*.

Image 5–28 EAP-TLS

2. Fill out the *Domain* and *Identity*.
3. Select the certification method. Click on the drop down box and select the desired method.
  - Manually provide Client & CA certificates
  - Auto enrollment via SCEP

## Manually providing certificates

1. Upload client certificate. Click on Choose file and browse to the desired file.

Allowed file formats:

- .pfx (PKCS#12)
- .p12 (Base64 encoded DER)

The should at least include the client certificate and corresponding private key.

2. Enter the Client certificate Password.
3. Upload CA certificate. Click on Choose file and browse to the desired file.

The following formats are allowed:

- .pem
- .cer
- .crt
- .pb7 (Base64 encoded DER)

File should at least contain the root CA certificate for your domain.

4. Save configuration

## Using Auto enrollment

The Simple Certificate Enrolment Protocol (SCEP) is a protocol which enables issuing and revoking of certificates in a scalable way. SCEP support is included to allow a quicker and smoother integration of the ClickShare Base Unit and Buttons into the corporate network.

Up until Base Unit firmware version 02.11.01 the SCEP implementation was specifically targeted at the Network Device enrollment Service (NDES) which is part of Windows Server. From Base Unit firmware version 02.12.00 and later we support both NDES and standard SCEP.

**NDES requires the following parameters:**



**SCEP Server:** This is the IP or hostname of the Windows Server in your network running the NDES service. Only http is allowed. E.g.: http://myserver or http://10.192.5.1

**SCEP username:** This is a user in your Active Directory which has the required permission to access the NDES service and request the challenge password. To be sure of this, the user should be part of the CA Administrators group (in case of a stand-alone CA) or have enrol permissions on the configured certificate templates.

**SCEP Password:** The corresponding password for the SCEP username that you are using to authenticate on service.

**Common Name:** The identity you want to link to the certificate.

The screenshot shows a configuration form for NDES. It includes a dropdown menu for 'Provide certificate' set to 'Auto enrollment via NDES'. Below it are text input fields for 'SCEP server' (containing 'http://' and a suffix '/CertSrv/mscep\_admin/'), 'SCEP username', 'SCEP password', and 'Common Name' (containing 'ClickShare-0004A50110C4').

Image 5–29 LAN Settings, Wireless Client, EAP-TLS, NDES

**SCEP requires the following parameters:**

**SCEP Server:** This is the IP or hostname of Server the server running the SCEP service with the port and suffix appended. Only http is allowed. E.g.: http://myserver:8080/scep or http://10.192.5.1/test

**SCEP Challenge:** The corresponding SCEP challenge password.

**Common Name:** The identity you want to link to the certificate.

The screenshot shows a configuration form for SCEP. It includes a dropdown menu for 'Provide certificate' set to 'Auto enrollment via SCEP'. Below it are text input fields for 'SCEP server' (containing 'http://'), 'SCEP challenge', and 'Common Name' (containing 'ClickShare-0004A50110C4').

Image 5–30 LAN Settings, Wireless Client, EAP-TLS, SCEP

## 5.19 LAN Settings, EAP-TTLS security mode

### About EAP-TTLS

EAP-TTLS (Tunneled Transport Layer Security) is an EAP implementation by Juniper networks. It is designed to provide authentication that is as strong as EAP-TLS, but it does not require each user to be issued a certificate. Instead, only the authentication servers are issued certificates. User authentication is performed by password, but the password credentials are transported in a securely encrypted tunnel established based upon the server certificates.

User authentication is performed against the same security database that is already in use on the corporate LAN: for example, SQL or LDAP databases, or token systems. Since EAP-TTLS is usually implemented in corporate environments without a client certificate we have not included support for this. If you prefer using client certificates per user we suggest using EAP-TLS.

### How to setup EAP-TTLS

1. Select Authentication Mode *EAP-TTLS*.

Image 5–31 EAP-TTLS

## 2. Fill out the *Domain* and *Identity*.

Domain	The company domain for which you are enrolling, should match with the one defined in your Active Directory.
Identity	Identity of the user account in the Active Directory which will be used by the ClickShare Buttons to connect to the corporate network.

## 3. Enter the *Password*.

The corresponding password for the identity that you are using to authenticate on the LAN network. Per Base Unit each Button will use the same identity and password to connect to the corporate network.

## 4. Optionally, upload the CA certificate.

The following formats are allowed:

- .pem
- .cer
- .crt
- .p7b (Base64 encoded DER)

File should at least contain the root CA certificate for your domain.

## 5. Click **Save configuration**.

# 5.20 Services, Mobile devices

## ClickShare app

The ClickShare app is enabled by default and makes it possible to connect with a mobile device to the Base Unit.

## About streaming information via AirPlay

Before you can stream information and display it via ClickShare your device must be connected with the wireless network of the Base Unit. Then AirPlay must be activated on your device. For more information about activating AirPlay, consult the user guide of your device.

The supported versions of AirPlay can be found on Barco's website, [www.barco.com/clickshare](http://www.barco.com/clickshare). The support of non-released version of these protocols cannot be guaranteed by Barco.

## About streaming via Google Cast

Before you can mirror information and display it via ClickShare your device must be connected with the wireless network of the Base Unit. When activating Google Cast on your device an overview of the access points is given. For more information about using Google Cast, consult the user guide of your device.

The supported versions of Google Cast can be found on Barco's website, [www.barco.com/clickshare](http://www.barco.com/clickshare). The support of non-released version of these protocols cannot be guaranteed by Barco.

Google Cast does not support a passcode.



Google Cast can only be used when the clock of the Base Unit is set correctly. If not Google Cast cannot make a connection with the Base Unit.

## About streaming via Miracast™

Miracast™ enables seamless display of multimedia content between Miracast® devices. Miracast allows users to wirelessly share multimedia, including high-resolution pictures and high-definition (HD) video content between Wi-Fi devices, even if a Wi-Fi network is not available.

Miracast sets up its own network to stream information and display it via ClickShare so there is no need for a direct connection with the Base Unit. Miracast must be activated on your device. For more information about activating Miracast, consult the user guide of your device.

The supported versions of Miracast can be found on Barco's website, [www.barco.com/clickshare](http://www.barco.com/clickshare). The support of non-released version of these protocols cannot be guaranteed by Barco.



To be able to use Miracast, you need to disable the access point and integrate the Buttons into the corporate network.

## Passcode type selection

1. Log in to the *Configurator*.
2. Click *Wi-Fi & Network* → *Services*.

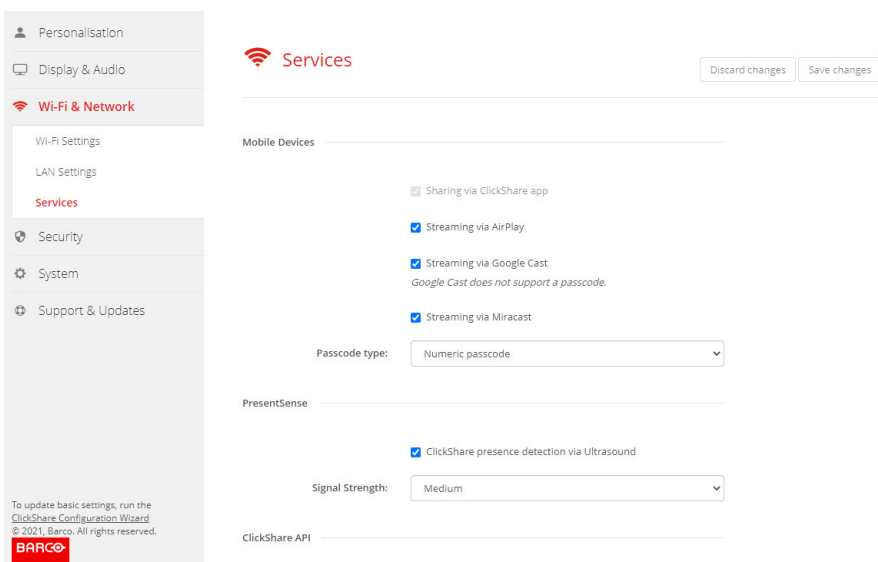

Image 5–32 Services, mobile devices

3. To allow sharing content via ClickShare app, *Sharing via ClickShare app* is activated by default and cannot be changed.

To allow streaming via AirPlay, check the check box in front of *Streaming via AirPlay*.

To allow streaming (mirroring) via Google Cast, check the check box in front of *Streaming via Google Cast*. Google cast does not support a passcode.

To allow streaming via Miracast, check the check box in front of *Streaming via Miracast*.

**Note:** from firmware version 2.12, after a factory reset, AirPlay, Google Cast and Miracast are deactivated.

4. Click on the drop down box and select the desired passcode type.
  - No passcode
  - Numeric passcode

Passcode applies to all BYOD screen sharing except Google Cast.

## 5.21 Service, PresentSense

### About PresentSense

The PresentSense function makes it easy to connect to a Base Unit when walking in meeting room. When this function is enabled and the ClickShare desktop app is installed on the user's PC, when walking in a meeting room the Base Unit detects via ultrasound, which contains the device ID and pin code, your presence and makes the connection with the included pin code after the user click **Connect** on a popup on his PC..

The app will connect and disconnect automatically when you enter or leave the meeting room. No meeting room selection nor entering pin codes is necessary. Only those in the room can see and hear what you do.

### How to activate

1. Log in to the *Configurator*.
2. Click *Wi-Fi & Network* → *Services*.

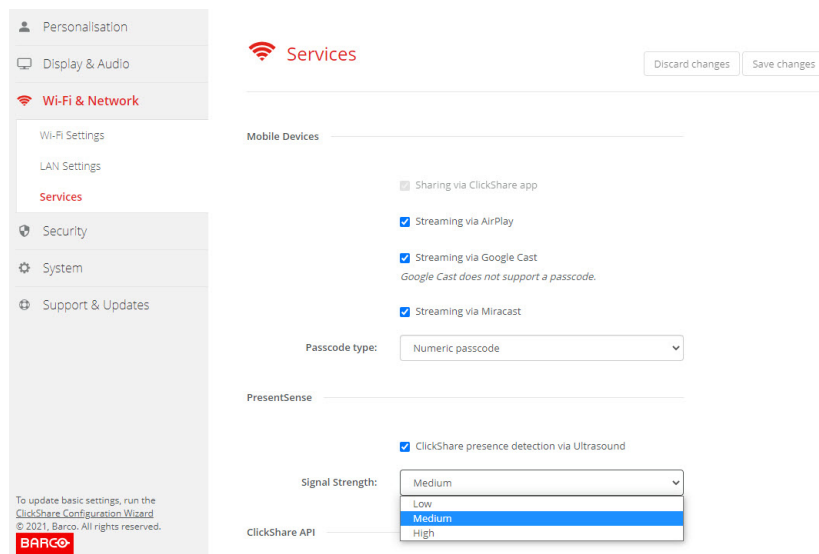

Image 5–33 PresentSense

3. In the *PresentSense* pane, check the check box next to *ClickShare presence detection via Ultrasound*.  
Checked: PresentSense detection activated.  
Not checked: PresentSense detection not activated.
4. Select the signal strength by clicking on the drop down box next to *Signal Strength*.  
The following options are possible:
  - Low
  - Medium
  - High

## 5.22 Service, ClickShare API, remote control via API

### About API settings

The API can be enabled or disabled, that means that the access to the unit from an external device can be allowed or can be blocked.

This functions in enabled by default.

### API documentation

The API documentation is included in the Base Unit. Just click on *View API documentation* to access to the documentation. Enter your user name and password to access the stored documentation on the Base Unit.



The default user name and password are identical to those of the configurator (admin/admin). This can be changed in *Security* → *Passwords*.

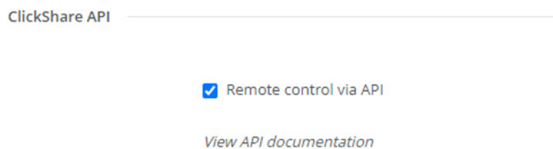

Image 5–34 ClickShare API & documentation

### How to enable remote control via API

1. Log in to the *Configurator*.
2. Click *Wi-Fi & Network* → *Services*.
3. Check the check box in front of *Remote control via API* to enable this function.

This check box is normally checked by default.

Checked: remote control via API is allowed. A password can be used to protect the access.

Not checked: no remote control via API allowed.

### About API documentation

The complete API documentation for integration by 3th parties is stored on the Base Unit and protected by user name and password.

### How to display the API documentation

1. Log in to the *Configurator*.
2. Click on *View API documentation*.
3. Enter your user name and password and click **OK**.

The documentation is displayed as a clickable HTML page.

## 5.23 Services, SNMP

### About SNMP

Simple Network Management Protocol (SNMP) is an internet standard protocol for collecting and organizing information about managed devices on IP networks and for modifying that information to change device behaviour. In general a SNMP management suite (running on a server) communicates with an SNMP agent (running on the device). The SNMP agent collects and exposes device information in the form of variables

according a MIB (Management Information Base). SNMP management suites will be able to approach ClickShare devices via SNMP protocol for requesting device information.

SNMPv3 is supported.

## How to enable

1. Log in to the *Configurator*.
2. Click *Wi-Fi & Network* → *Services*.
3. Scroll to *SNMP*.

SNMP

Enable

Engine ID:

Use default Engine ID

SNMP Manager:

Username:

New password:

Confirm password:

Image 5–35 Service, SNMP

4. Check the check box in front of *Enable*.  
The configuration fields become available.

## How to configure

1. When using the default *Engine ID*, make sure the check box before *Use default Engine ID* is checked.  
The default engine ID is a combination of the Barco Enterprise Number with the MAC-address (eth0).
2. Fill out the *SNMP Manager* address.  
That is the host address which will receive the TRAP events/messages.  
Possible traps can be:
  - Alarm CPU temperature trap which indicates that CPU temperature exceeds the threshold.
  - Alarm Case Fan Speed trap which indicates the case fan is spinning too slow.
  - Alarm Process Not Running trap which indicates one of the monitored processes is not running.
3. Enter the *Username*.
4. Enter a new password and confirm that password.

# 5.24 Security, security level

## About security levels

For the use of the ClickShare system, a security level can be set. By default, level 1 is activated. A security level is a predefined set of settings which are automatically set when a level is selected.

**Level 1** : offers support for normal day-to-day operations in any organization.

Level 1 contains the standard security options and encryption of audio and video data.

The standard security options are:

- PIN code activation for mobile apps and Buttons,
- ClickShare Configurator (WebUI) access via HTTPS with login management,

- no wireless ClickShare Configurator (WebUI) access and Remote control via API,
- SSID of Wi-Fi network is hidden.

**Level 2** : this level offers a higher degree of security, fit for organizations that are more sensitive to security matters.

Level 2 contains the level 1 security and a mandatory PIN code for mobile devices. Alphanumeric PIN codes for mobile apps and Buttons and the Buttons require a certificate for pairing.

**Level 3** : this level is used for organizations that have extremely strict requirements with regards to security.

Level 3 contains the level 2 security extended with blocking of mobile apps, downgrading firmware not possible and no wireless access to the Configurator (WebUI).

When a security level is set, the individual items included in that security level can be changed using the individual item in the Configurator. When changing an individual item the security level indication will be adapted accordingly, but no other settings will be changed automatically.

E.g. when level 3 is set and you change mobile app blocking to allowed, then the security level indication will change to level 2. But all other items initially in level 3 remains in the level 3 state.



To reset your individual changes, select the desired security level and click **Save changes**.



Changing the security level will require a re-pairing of the Buttons.

Changing the security level from 1 to a higher level will change the compatibility setting for Buttons with certificate (R9861006D01). They cannot re-pair as long as the security setting is higher than level 1.

## How to set the security level

1. Log in to the *Configurator*.
2. Click *Security* → *Security Level*.

**Security Level**

	1	2	3
Activate passcode for mobile apps & Buttons	✓	✓	✓
ClickShare Configurator: HTTPS, Log-in management, disable wireless access	✓	✓	✓
Hide the SSID of the Wi-Fi network	✓	✓	✓
Mandatory passcode for mobile apps & services <sup>2</sup>		✓	✓
BYOD services and features are blocked			✓
Firmware downgrade not possible			✓
No wireless access to ClickShare Configurator and Remote control via API <sup>3</sup>			✓
Saving annotations to clients and USB drives disabled			✓

**Remarks:**

<sup>1</sup> Changing the security level will require Button re-pairing.  
<sup>2</sup> Google Cast does not support a passcode. You can disable Google Cast through the Services section (click here).  
<sup>3</sup> Remote management will not be available on wireless interface in security level 3.

Image 5–36 Security levels

3. Select the desired security level icon.
4. Click **Save changes** to apply the setting.

## 5.25 Security, passwords

### About passwords

To access the ClickShare Configurator a user name and password is needed. That password can be changed at any time to protect the *ClickShare Configuration* settings.

### Changing the ClickShare Configurator & API password

1. Log in to the *Configurator*.
2. Click *Security* → *Passwords*.

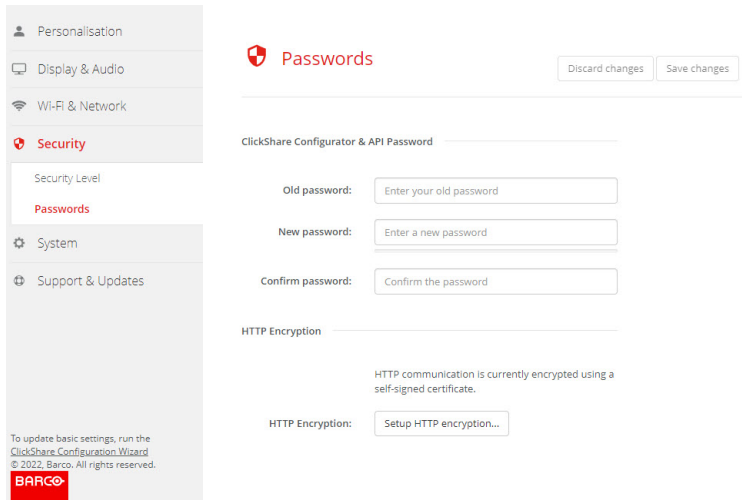

Image 5–37 Passwords

3. Click in the *Password* pane in the input field next to *Old password* and enter the old password.
4. Click in the input field next to *New password* and enter a new password.
5. Click in the input field next to *Confirm password* and enter the new password again.
6. Click **Save changes** to apply.

## 5.26 Security, HTTP Encryption

### About HTTP encryption

HTTP encryption can be set up by using a self signed certificate or a custom certificate. By default, a self signed certificate is used.

### How to setup

1. Log in to the *Configurator*.
2. Click *Security* → *Passwords*.



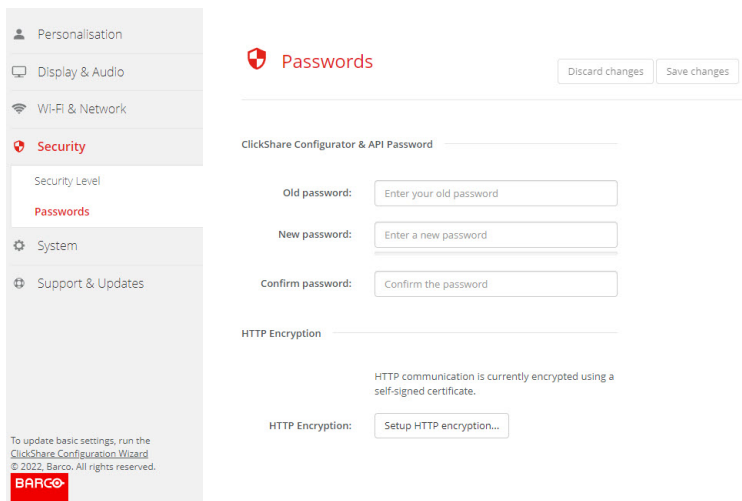

Image 5–38 HTTP Encryption

**3. Click on **HTTP encryption...****

**4. Choose the certificate.**

The following options are possible:

- Use a self signed certificate
- Use a custom certificate.

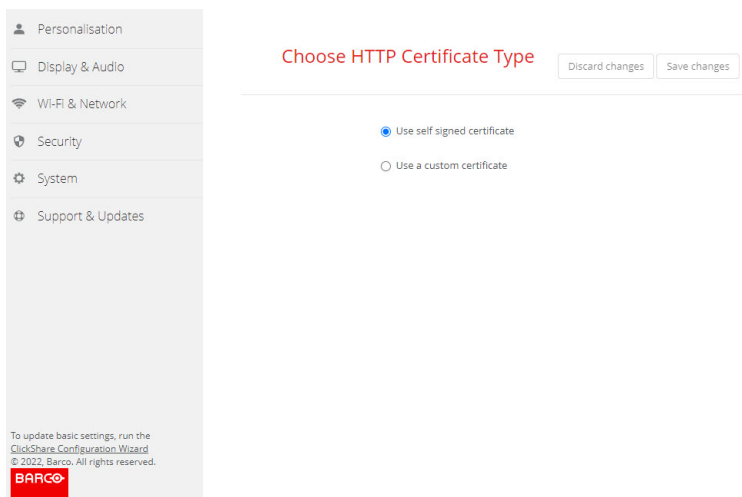

Image 5–39 HTTP encryption

## Custom certificate upload

**1. Enter your passphrase.**

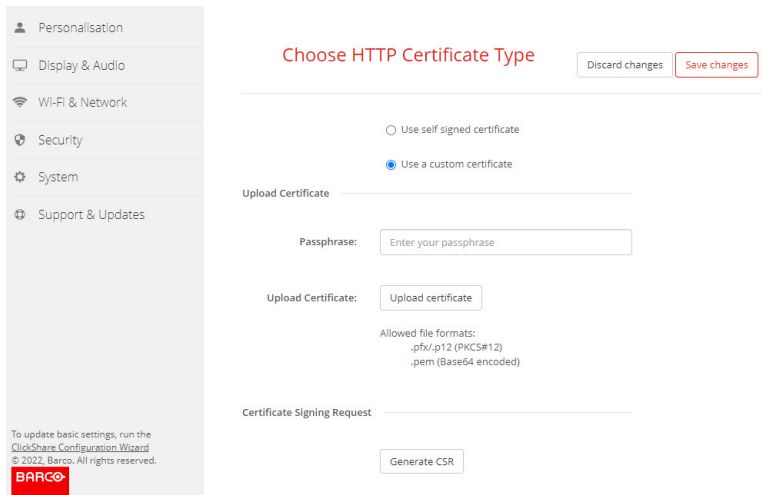

Image 5–40 Upload custom certificate

2. Click on **Upload certificate**.  
A browser window opens.
3. Select the desired custom certificate file and click Open.  
The allowed file formats are:
  - .pfx/.p12 (PKCS#12)
  - .pem (Base64 encoded)
4. Click on **Generate CSR** .  
A *Download Certificate Signing Request* page opens.
5. Fill out the page and click **Download**.  
A CRS file will be created and downloaded to your computer.

## 5.27 Status information Base Unit

### Status information

The following information can be found:

- Model information, name and part number
- Serial number
- Firmware version
- First used
- Last used
- Current uptime: time since last startup
- Lifetime uptime: time used since first startup
- Overall status

### Base Unit restart

1. Log in to the *Configurator*.
2. Click *Support* → *Base Unit Status*.

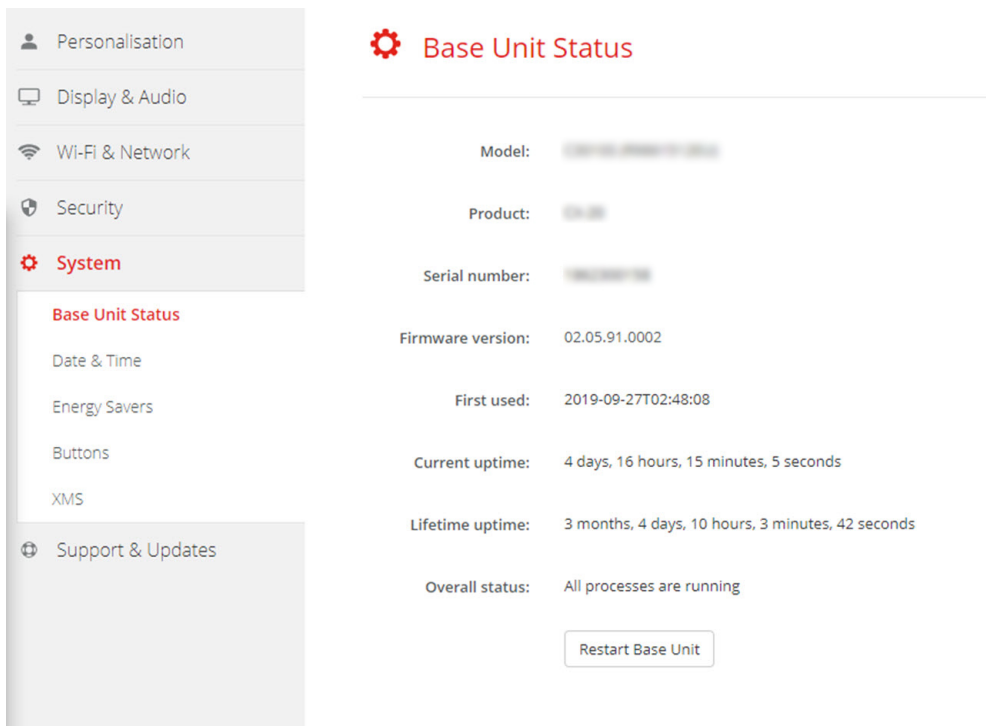

Image 5–41

3. To restart the Base Unit, click on **Restart Base Unit**.

A ClickShare system reboot message with progress bar is displayed while rebooting takes place.

When the reboot is finished, a re-login is necessary.

## 5.28 Date & Time setup, manually

### About Date & Time setup

The date and time can be set manually using the time zone indication or using at least one NTP servers.

### How to setup

1. Log in to the *Configurator*.
2. Click *System* → *Date & Time*.

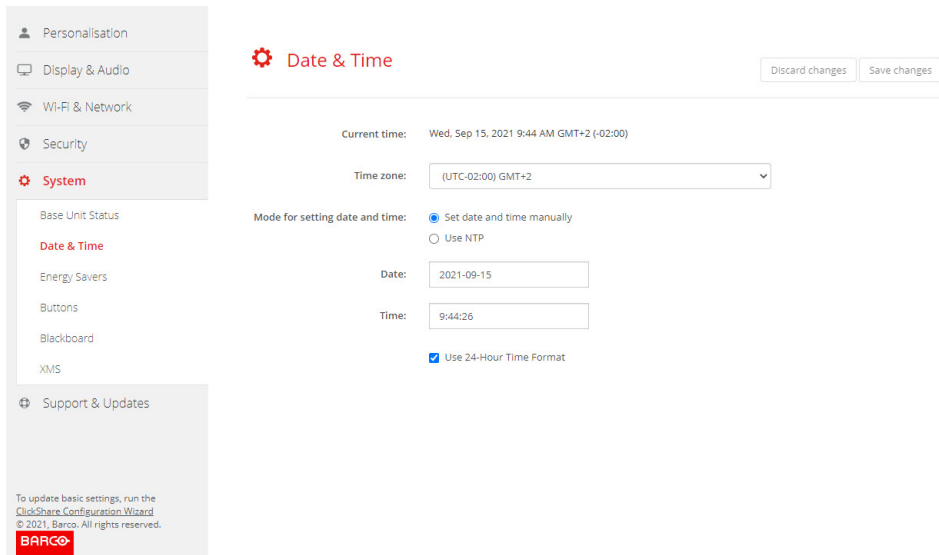

Image 5–42 Manual time & date update

The current time is indicated next to *Current time*.

3. Select your time zone. Click on the drop down box next to *Time zone* and select the corresponding time zone.
4. Check the radio button in front of *Set time and date manually*.
5. To change the date, click in the input field next to *Date*.

A calendar window opens. The current date is indicated with a red background.

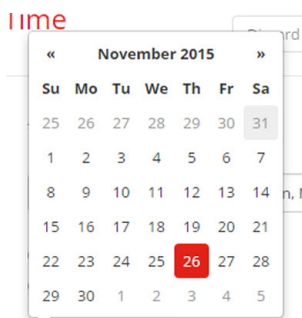

Image 5–43 Date selection

6. To change the month, click on the left or right arrows next the month name until the desired month and year are obtained.

Click on a number in the number field to setup the day.

7. To change the time, click in the time field next to *Time*.

A window with 3 scroll counters open.



Image 5–44 Time setup

8. Click on the up down arrow of each scroll counter until the correct hour, minutes and seconds are obtained.

9. Select the time format.

Checked: use of 24 hour time format

Not checked: use of 12 hour time format

10. Click **Save changes** to apply.

## 5.29 Date & Time setup, time server

### About using NTP server

The clock is continuously synchronized with an external time server and the deviation is in the order of milliseconds. Extra time servers can be added.

As long as there is no synchronization with a time server the status is indicated as disabled.

### How to setup

1. Log in to the *Configurator*.
2. Click *System* → *Date & Time*.

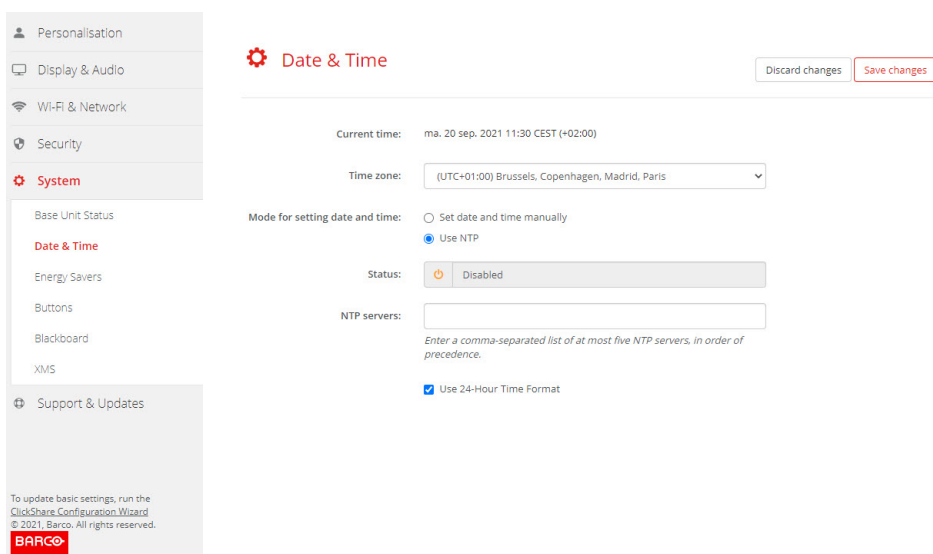



Image 5–45 Time server setup

The current time is indicated next to *Current time*.

3. Check the radio button next *Use NTP*.
4. Enter a NTP server address next to *NTP servers*. Enter the IP address or server name.

 **Note:** Multiple servers (maximum 5) can be added, separated by a comma.

5. Select the time format.

Checked: use of 24 hour time format

Not checked: use of 12 hour time format

6. Click **Save changes** to apply.

A synchronization with the NTP server takes place. The status field indicates the progress.

## 5.30 Energy savers

### About standby

**Standby after (minutes):** If there is no client connection detected during the standby timeout period, the Base Unit will enter the selected standby mode.

Default setting: Time to standby: 10 min, the Base Unit will enter the Eco standby mode.

## Eco mode

When the Base Unit enters ECO standby mode, it will disable the HDMI output signal. The Base Unit's LEDs will be breathing white to indicate the ECO standby mode.

Power consumption in Eco standby: 2.6W

The Base Unit will wake up with one of the following actions:

- Button or app connecting with the Base Unit
- Press the standby button on the Base Unit
- Pairing a Button on the Base Unit's USB port
- Plugging in an HDMI display
- When a CEC event is received

## Standby mode

When the Base Unit goes in Deep standby mode, it will shut down all processes, including the Wi-Fi access point and LAN connection. The Base Unit's LEDs will be dark to indicate this standby mode.

The Base Unit will wake up only when the standby button on the Base Unit is pressed.

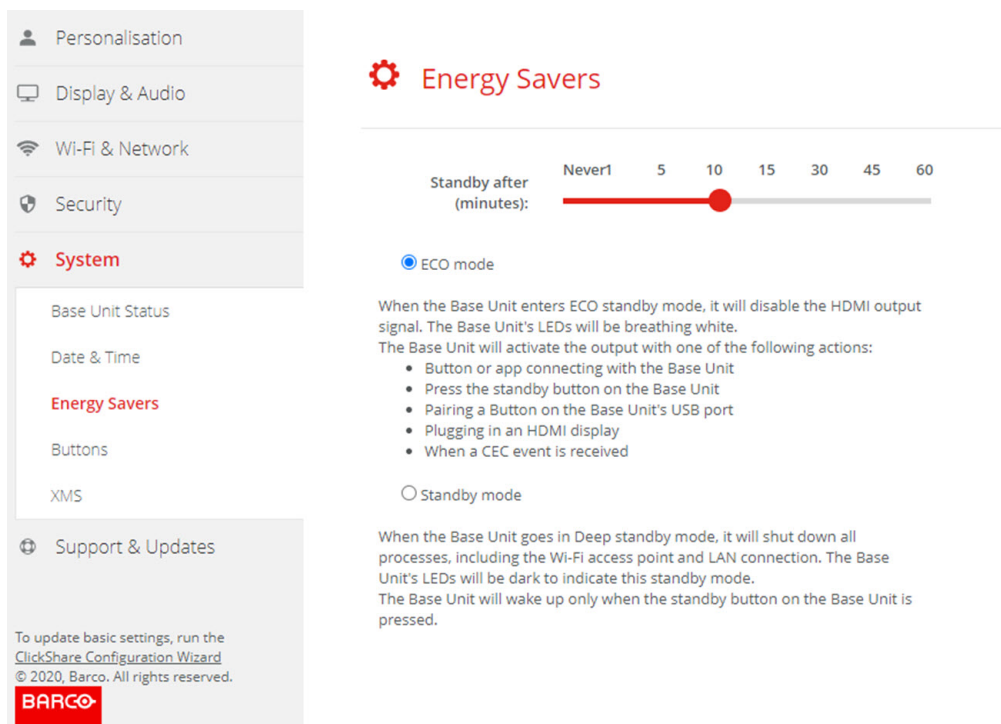

Image 5-46 Energy savers

## How to change the display timeout

1. Log in to the *Configurator*.
2. Click *System* → *Energy Savers*.
3. To set a display time out, move the slider to the left or to the right until the desired standby timeout is reached.

# 5.31 Buttons

## About Buttons

The Button page indicates to which Base Unit or network the Buttons are connected. It indicates also the current state.

When connected to a network, it indicates the domain, the identity and provided certificate.

All Buttons used with the Base Unit are indicated in the Buttons List. The list contains the serial number, MAC address, article code and the firmware version, the number of connections and last connection date and time.

It is possible to update the software of the Buttons over Wi-Fi.

The Buttons can be connected to Base Unit or to an external access point.

## To edit the settings

1. Log in to the *Configurator*.
2. Click *System* → *Buttons*.

The screenshot shows the 'Buttons' configuration page. On the left, a sidebar menu has 'System' selected, and 'Buttons' is highlighted. The main content area has a red gear icon and the title 'Buttons'. Below the title, there is a button 'Edit settings'. Underneath, it says 'Buttons connect to: ClickShare-Malta (5 GHz)'. There are buttons for 'Select all', 'Select none', and 'Remove'. A table lists the buttons with the following data:

Select	Serial number	MAC address	Article code	Firmware	Connections	Last connection
<input type="checkbox"/>	1860000116	3C:E1:A1:0C:C1:C0	R9861600D01C	04.08.00.0003	286	2021-03-18T12:07:38
<input type="checkbox"/>	1860000274	3C:E1:A1:0D:3D:9A	R9861600D01C	04.08.00.0003	168	2021-03-16T15:09:25
<input type="checkbox"/>	1860000113	3C:E1:A1:0C:C1:68	R9861600D01C	04.08.00.0003	9	2021-02-26T12:32:03
<input type="checkbox"/>	1860000313	3C:E1:A1:0D:44:DC	R9861600D01C	04.08.00.0003	1	2021-02-26T12:28:59

Image 5–47 Buttons overview

The current state is indicated and the list of Buttons is given.

3. Click **Edit settings**.
4. Select to which access point the Buttons are connected. Click on the drop down list next to *Buttons connect to* and select the desired point.

Depending on the selection, your ClickShare device or external access point, settings should be filled out.

For your ClickShare device, no settings are needed.

## 5.32 Buttons, External access point, mode EAP-TLS

### How to fill out

1. Fill out a *Corporate SSID*.

The screenshot shows the 'Buttons' configuration window. At the top, there is a gear icon and the title 'Buttons'. To the right are 'Cancel' and 'Save changes' buttons. Below the title bar, the 'Buttons connect to:' dropdown is set to 'External Access Point'. Under the 'External Access Point Settings' section, the 'Authentication Mode:' dropdown is set to 'EAP-TLS'. The 'Corporate SSID:' field contains 'Home Sweet Home'. The 'Domain:' and 'Identity:' fields are empty. The 'Provide certificate:' dropdown is set to 'Manually provide Client & CA certificates'. Below this, there are two file upload sections: 'Upload client certificate:' and 'Upload CA certificate:'. Each has a 'Bestand kiezen' button and a 'Geen bestand gekozen' status. The client certificate section includes a text box for the password and a note: 'Allowed file formats: .pfx (PKCS#12), .p12 (Base64 encoded DER). File should at least include the client certificate and corresponding private key.' The CA certificate section includes a note: 'Allowed file formats: .pem, .cer, .crt, .p7b (Base64 encoded DER). File should at least contain the root CA certificate for your domain.'

Image 5–48 Buttons, External access point, mode EAP-TLS

The SSID of your corporate wireless infrastructure to which the ClickShare Buttons will connect.

2. Fill out the *Domain* and *Identity*.
3. Select the certification method. Click on the drop down box and select the desired method.
  - Manually provide Client & CA certificates
  - Auto enrollment via SCEP

## Manually providing certificates

1. Upload client certificate. Click on Choose file and browse to the desired file.

Allowed file formats:

- .pfx (PKCS#12)
- .p12 (Base64 encoded DER)

The should at least include the client certificate and corresponding private key.

2. Enter the Client certificate Password.
3. Upload CA certificate. Click on Choose file and browse to the desired file.

The following formats are allowed:

- .pem
- .cer
- .crt
- .pb7 (Base64 encoded DER)

File should at least contain the root CA certificate for your domain.

4. Save Changes

## Using Auto enrollment

The Simple Certificate Enrolment Protocol (SCEP) is a protocol which enables issuing and revoking of certificates in a scalable way. SCEP support is included to allow a quicker and smoother integration of the ClickShare Base Unit and Buttons into the corporate network.



Up until Base Unit firmware version 02.11.01 the SCEP implementation was specifically targeted at the Network Device enrollment Service (NDES) which is part of Windows Server. From Base Unit firmware version 02.12.00 and later we support both NDES and standard SCEP.

**NDES requires the following parameters:**

**SCEP Server:** This is the IP or hostname of the Windows Server in your network running the NDES service. Only http is allowed. E.g.: http://myserver or http://10.192.5.1

**SCEP username:** This is a user in your Active Directory which has the required permission to access the NDES service and request the challenge password. To be sure of this, the user should be part of the CA Administrators group (in case of a stand-alone CA) or have enrol permissions on the configured certificate templates.

**SCEP Password:** The corresponding password for the SCEP username that you are using to authenticate on service.

**Common Name:** The identity you want to link to the certificate.

Image 5–49 Button Settings, Wireless Client, EAP-TLS, NDES

**SCEP requires the following parameters:**

**SCEP Server:** This is the IP or hostname of Server the server running the SCEP service with the port and suffix appended. Only http is allowed. E.g.: http://myserver:8080/scep or http://10.192.5.1/test

**SCEP Challenge:** The corresponding SCEP challenge password.

**Common Name:** The identity you want to link to the certificate.

Image 5–50 Button Settings, Wireless Client, EAP-TLS, SCEP

## 5.33 Buttons, External access point, mode EAP-TTLS

### How to fill out the settings

1. Fill out a *Corporate SSID*.

The screenshot shows the 'Buttons' configuration page. At the top left is a gear icon and the word 'Buttons'. To the right are 'Cancel' and 'Save changes' buttons. Below is a dropdown menu for 'Buttons connect to:' set to 'External Access Point'. A section titled 'External Access Point Settings' contains several fields: 'Authentication Mode:' set to 'EAP-TTLS', 'Corporate SSID:' with the value 'Home Sweet Home', and empty fields for 'Domain:', 'Identity:', and 'Password:'. At the bottom, there is an 'Upload CA certificate (optional):' section with a 'Bestand kiezen' button and a message: 'Geen bestand gekozen. Allowed file formats: .pem, .cer, .crt, .p7b (Base64 encoded DER). File should at least contain the root CA certificate for your domain.'

Image 5–51 Buttons, External access point, mode EAP-TTLS

The SSID of your corporate wireless infrastructure to which the ClickShare Buttons will connect.

2. Fill out the *Domain* and *Identity*.
3. Enter a *Password*.
4. Upload CA certificate. Click on Choose file and browse to the desired file.

The following formats are allowed:

- .pem
- .cer
- .crt
- .p7b (Base64 encoded DER)

File should at least contain the root CA certificate for your domain.

5. Click **Save Changes** to save the settings.

## 5.34 Buttons, External access point, mode PEAP

### How to fill out the settings

1. Fill out a *Corporate SSID*.

The screenshot shows the 'Buttons' configuration window. At the top left is a gear icon and the title 'Buttons'. To the right are 'Cancel' and 'Save changes' buttons. Below the title bar, there is a dropdown menu labeled 'Buttons connect to:' with 'External Access Point' selected. Underneath is a section titled 'External Access Point Settings'. It contains several fields: 'Authentication Mode:' with a dropdown menu showing 'PEAP'; 'Corporate SSID:' with a text input field containing 'Home Sweet Home'; 'Domain:' with an empty text input field; 'Identity:' with an empty text input field; and 'Password:' with an empty text input field. At the bottom, there is a section for 'Upload CA certificate (optional):' with a button labeled 'Bestand kiezen' and a message: 'Geen bestand gekozen. Allowed file formats: .pem, .cer, .crt, .p7b (Base64 encoded DER). File should at least contain the root CA certificate for your domain.'

Image 5–52 Buttons, External access point, mode PEAP

The SSID of your corporate wireless infrastructure to which the ClickShare Buttons will connect.

2. Fill out the *Domain* and *Identity*.
3. Enter a *Password*.
4. Upload CA certificate. Click on Choose file and browse to the desired file.

The following formats are allowed:

- .pem
- .cer
- .crt
- .p7b (Base64 encoded DER)

File should at least contain the root CA certificate for your domain.

5. Click **Save Changes** to save the settings.

## 5.35 Buttons, External access point, mode WPA2-PSK

### How to fill out the settings

1. Fill out a *Corporate SSID*.

The screenshot shows the 'Buttons' configuration window. At the top left is a gear icon and the title 'Buttons'. To the right are 'Cancel' and 'Save changes' buttons. Below the title bar, there is a dropdown menu labeled 'Buttons connect to:' with 'External Access Point' selected. Underneath is a section titled 'External Access Point Settings'. It contains several fields: 'Authentication Mode:' with a dropdown menu showing 'WPA2-PSK'; 'Corporate SSID:' with a text input field containing 'Home Sweet Home'; and 'Passphrase:' with an empty text input field.

Image 5–53 Buttons, External access point, mode WPA2-PSK

The SSID of your corporate wireless infrastructure to which the ClickShare Buttons will connect.

2. Fill out Passphrase.

The key used in WPA2-PSK to authenticate onto the wireless infrastructure. This can be a string of 64 hexadecimal digits or a passphrase of 8 to 63 printable ASCII characters.

3. Click **Save changes** to save the settings.

## 5.36 Blackboard



Only available on C-10.

### About Blackboard

Saving information from a blackboard can be enabled or disabled. When enabled, the information is saved on hard disk of all connected Buttons, connected ClickShare apps and on the USB sticks connected with the Base Unit.

### How to change the blackboard setting

1. Log in to the *Configurator*.
2. Click *System* → *Blackboard*.

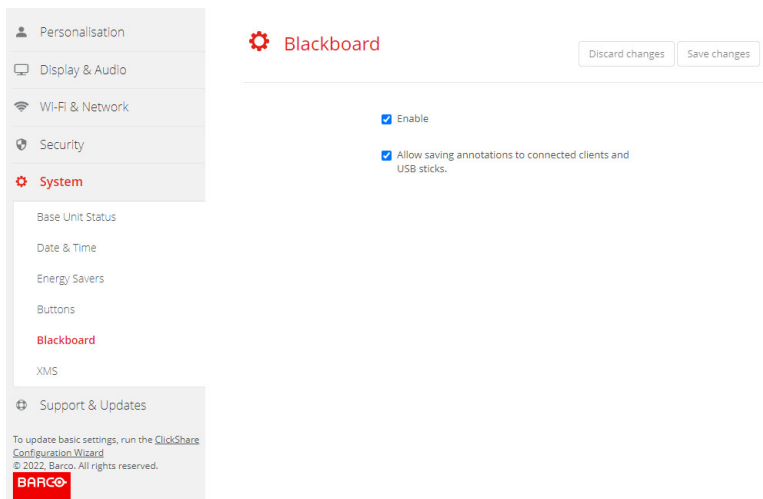

Image 5–54 Save annotations

3. To enable or disable Blackboarding check or uncheck the checkbox in front of enable or disable.  
Checked: blackboarding enabled  
Unchecked: blackboarding disabled.
4. Check or uncheck the check box in front of *Allow saving annotations to connected clients and USB sticks*.  
Checked: annotations on the blackboard can be saved.  
Unchecked: no annotations on the blackboard can be saved.

## 5.37 XMS Cloud Integration

### Overview

When your device is not registered and connected to the cloud service, the following message will be displayed: Device has not been added to XMS cloud. To add your device to XMS cloud click here <https://xms.barco.com/add>.

The device token is given and can be copied.

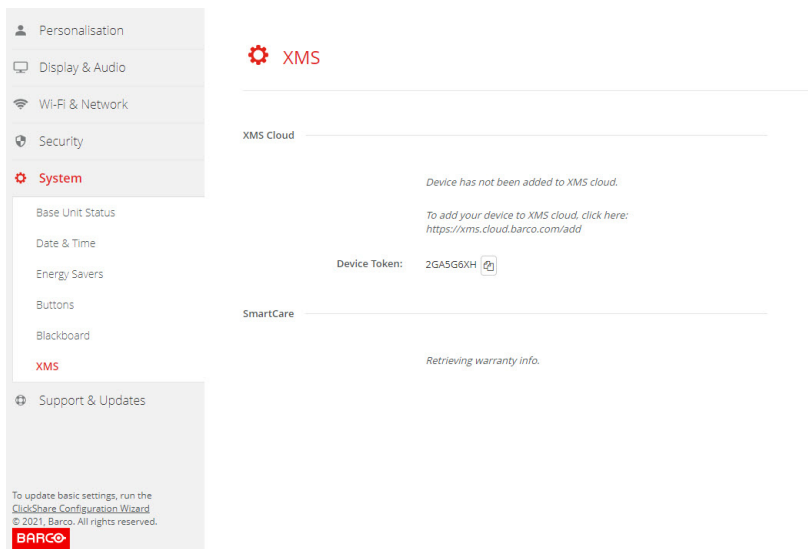

Image 5–55 XMS cloud, no registration

When your device is correctly registered, the following message is displayed: *The ClickShare device has been successfully registered.*

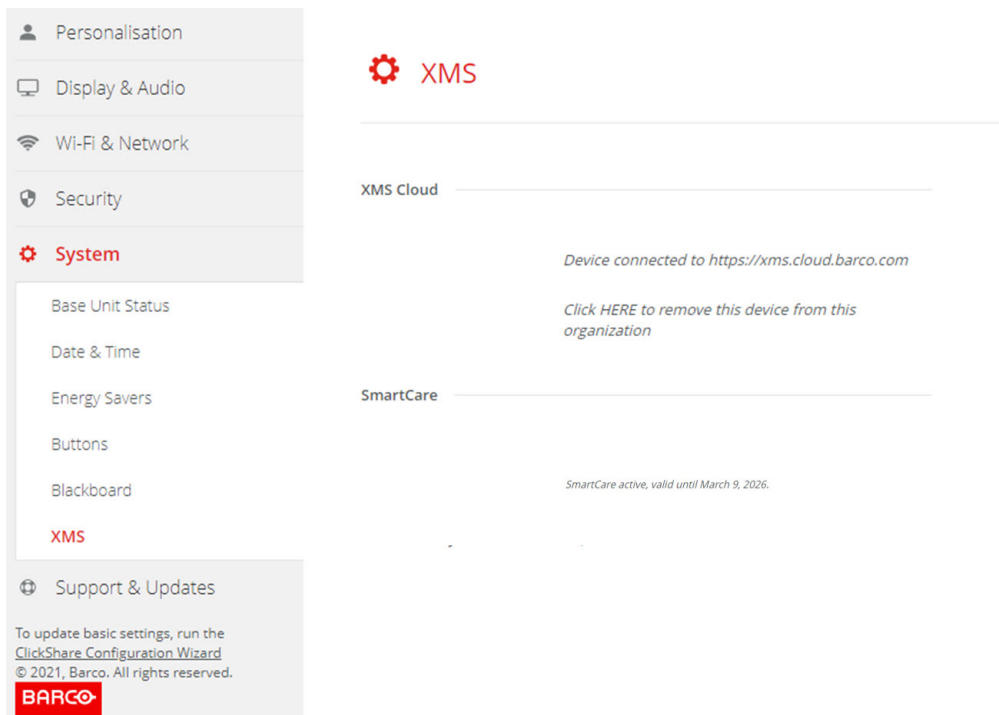

Image 5–56 XMS cloud

## What can be done?

1. Check your network settings or register your device to XMS Cloud.  
Follow procedure as described in [“Registration to XMS Cloud”, page 35.](#)

## SmartCare

The SmartCare package is included in the purchase of each ClickShare unit.

For those rare occasions when you encounter issues with our ClickShare units, we have launched SmartCare, a service package that provides your company with budget predictability, swift hardware replacement and expert support from both Barco and our partners for up to 5 years.

When SmartCare is activated, in the SmartCare pane the message *SmartCare active, valid until...* is displayed.

When not yet activated, you have 6 months after the first setup to activate SmartCare and enjoy 5 years of hardware coverage.

When the activation period is expired, the warranty end date will be displayed.

## 5.38 Firmware Update

### About Firmware update

The firmware of the Base Unit can be updated via the web interface. The latest version of the firmware is available on Barco's website.

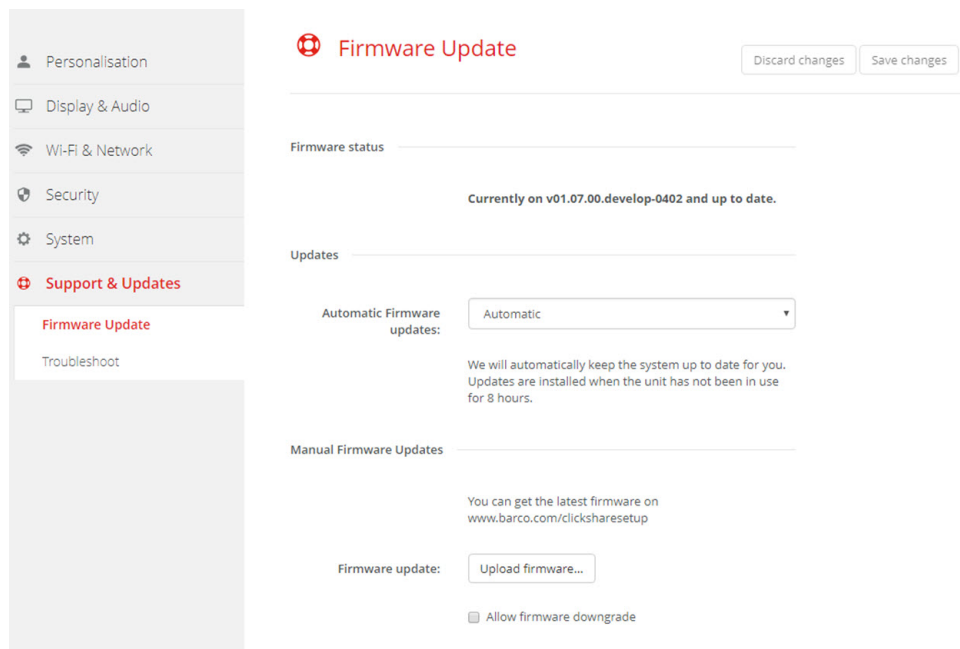

Image 5–57 Firmware update

### About automatic firmware updates

There are 3 ways to configure automatic updates:

- **Automatic:** The system will automatically detect firmware updates and install them for you when it's not in use.
- **Notify:** The system will automatically detect firmware updates and notify you on the web interface dashboard and firmware page. The update can then be initiated via the *Support & Updates > Firmware* page
- **Off:** The system will not detect firmware updates and will not notify you.

### Manual firmware update

1. Download the latest version of the firmware from Barco's website.
2. Log in to the *Configurator*.
3. Click *Support & Updates* → *Firmware*.
4. To upload a firmware version, click on **Upload firmware...**  
A browser window opens.
5. Browse to the file with the new firmware and click **Open** to start the upload.



**Note:** This should be an .enc file. You might have to unzip the file downloaded from Barco's website.

-  **Note:** Updating the software to the Base Unit takes several minutes. Progress can be followed on the meeting room display.

The Base Unit software is updated.



If a firmware downgrade is required on the Base Unit, check the check box in front of *Allow firmware downgrade*.

## Firmware update without using the Configurator

Next to using the configurator to upgrade the firmware, the following ways are also possible:

- When your device is connected to a network and managed via the XMS (Cloud) management platform, the firmware can be upgrade via this Management solution. For more information on upgrading firmware in this way, consult Barco's web pages on XMS (<https://www.barco.com/en/page/xms-cloud-management-platform>).
- Download the firmware on a USB stick and plug in this USB in your device. For more information, see "Updating the C-5, C-10 firmware", page 104

# 5.39 Support & Updates, Troubleshoot, log settings

## About logging

Both Button and Base Unit log data is saved in log files on the Base Unit. These log files can contain debugging information. They can be downloaded on a local computer and cleared on the Base Unit. Debug logging covers only a few hours before it will be overwritten. Therefore, it is important if you discover a problem with your system to download the logging immediately.

## How to use

1. Log in to the *Configurator*.
2. Click *Support & Updates* → *Troubleshoot*.

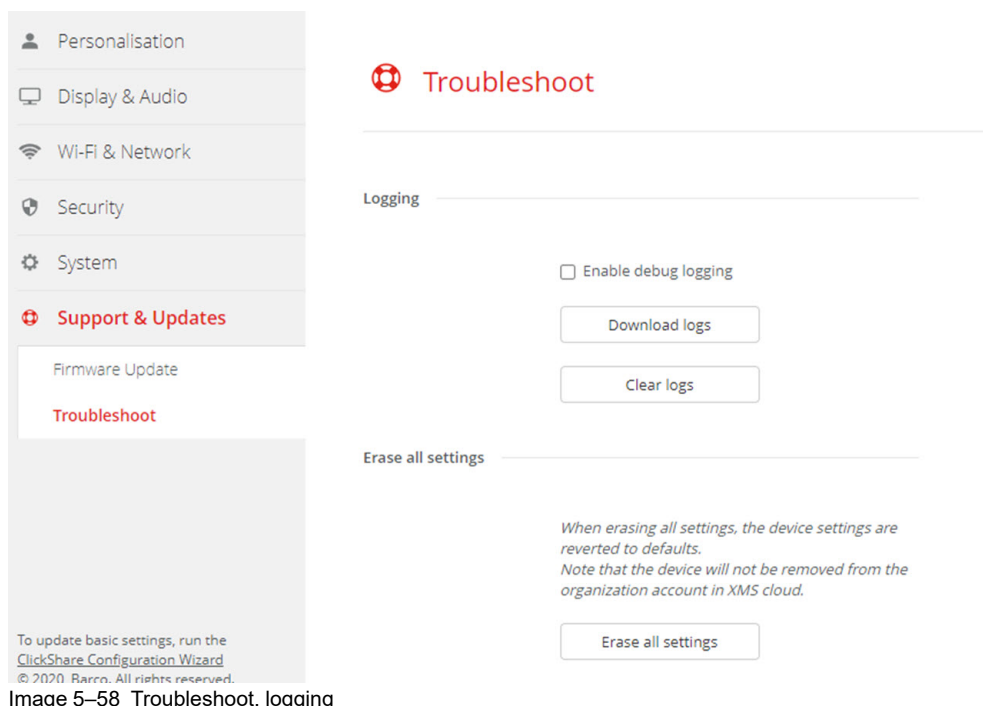

Image 5–58 Troubleshoot, logging

3. To create a debug log, check the check box next to *Enable debug logging*.
4. Reproduce the issue you want to report.

5. To download the current log file, click on **Download logs**.
6. To clear the current log file, click **Clear logs**.

## 5.40 Troubleshooting, Erase all settings

### About erasing all settings

When erasing all settings, the device settings are reverted to defaults. There is no need to go through the onboarding procedure.



The device will not be removed from the organization account in XMS cloud.

### How to erase

1. Log in to the *Configurator*.
2. Click *Support & Updates* → *Troubleshoot*.
3. To erase all settings and revert to default, click **Erase all settings**.

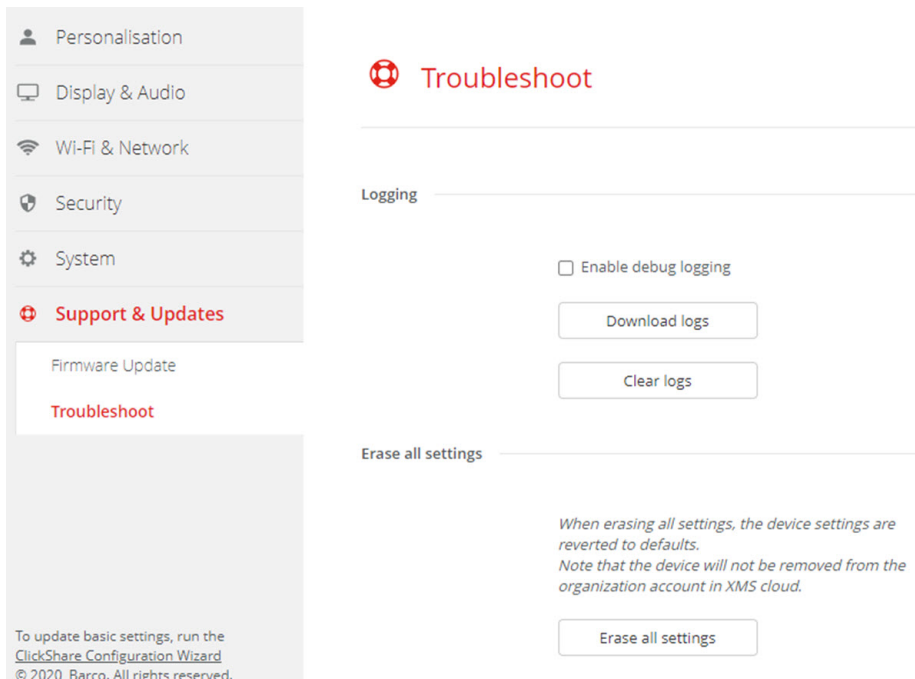

Image 5–59 Troubleshoot, logging

## 5.41 Reset to factory defaults

### About the reset

When applying a reset to factory defaults, the device settings are reverted to the factory defaults. Additionally, the Base Unit will be removed from the organization account in XMS cloud and the first time setup procedure will be initiated, as if the device came out of the box.



The unit needs to be connected to the internet to complete the first time setup.

### How to reset

1. Log in to the *Configurator*.



2. Click **Support & Updates** → **Troubleshoot**.

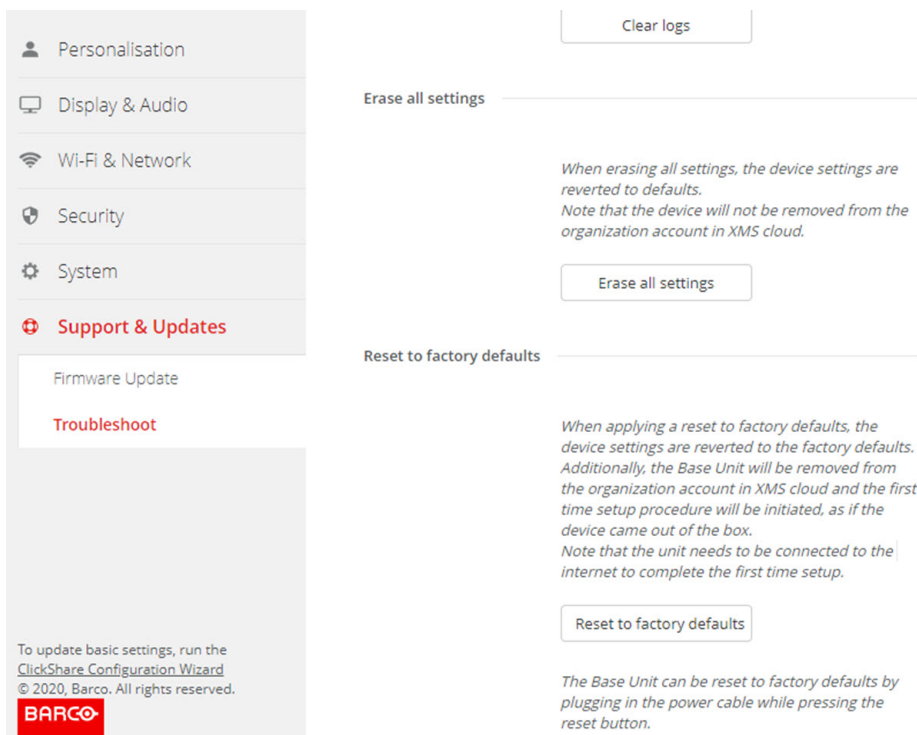

Image 5–60 Factory reset

3. Click **Reset to factory defaults**.

The following message is displayed: “This action will remove all settings of the Base Unit and replace them with the default settings. Are you sure you want to continue?”

4. If you want to continue, click **Yes, remove all settings** otherwise click **No, I changed my mind**.

When yes is clicked, the system starts a reboot.

## 5.42 Troubleshoot, diagnostics

### About diagnostics

A TCP dump test will capture the network data for 2 minutes and the result will be written in a separate file in the log archive. This file can only be opened with a network monitoring tool.

### How to start

1. Log in to the *Configurator*.
2. Click **Support & Updates** → **Troubleshoot**.
3. In the Diagnostics pane, click **Run TCP Dump Test**.

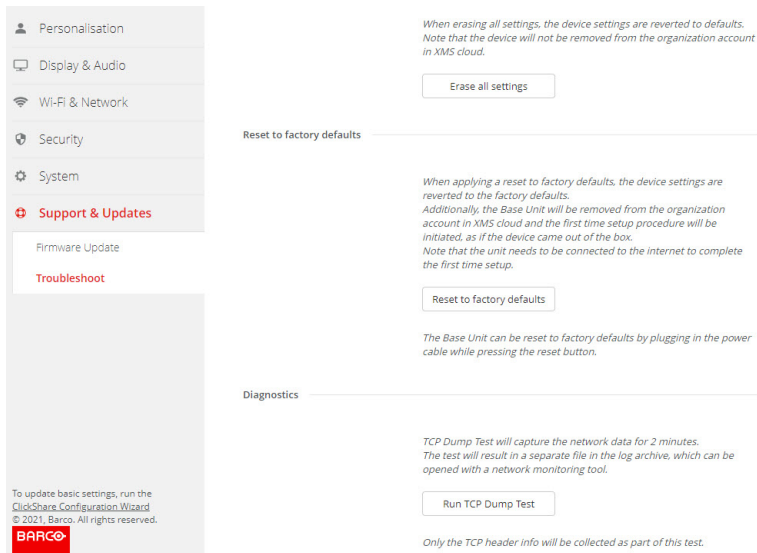

Image 5–61 Troubleshoot, diagnostics

A separate file is written to the log archive.

Only the TCP header info will be collected as part of this test.

# Firmware updates

# 6

6.1	Updating the C-5, C-10 firmware.....	104
-----	--------------------------------------	-----

## 6.1 Updating the C-5, C-10 firmware



When starting up the device for the first time a software update is necessary. This update can only be done via the network.

### About Firmware updates

There are different ways to update the Base Unit software:

- automatic update when connected with the network or your device is configured in XMS cloud.
- via the Configurator, for more information, see “[Firmware Update](#)”, page 98.
- by copying the software on a USB stick

### To update the Base Unit software by copying the software on a USB stick

1. Download the latest version of the firmware from Barco's website, [www.barco.com/clickshare](http://www.barco.com/clickshare). Click on **Support** and select the update firmware button of your device type.

2. Unzip the zip file.

3. Copy the ENC file to a USB stick.

You can have multiple firmwares for multiple device types on the same stick.

4. Insert the USB stick into the USB port at the front of the Base Unit.

5. Follow the instructions on the meeting room screen.

6. When the on-screen message indicates that the process is finished, remove the USB stick.

The Base Unit reboots.

# Troubleshooting

# 7

7.1	Troubleshooting list.....	106
-----	---------------------------	-----

## 7.1 Troubleshooting list

### Barco knowledge base and YouTube videos

Go to the product page on Barco's website and select in the right column **Support**. You will get access to Barco's *Knowledge base* (<https://www.barco.com/en/support/knowledge-base>) and *Latest tutorial videos*. For more YouTube videos, consult <https://www.youtube.com/user/barcoTV> and select ClickShare.

### Problem solving

Problem	Cause	Solution
Quality of the image on the meeting room display is not satisfactory	The quality or length of the cable between the Base Unit and the display or the connection between these two.	<ul style="list-style-type: none"> <li>• Replace the cable.</li> <li>• Use another cable.</li> </ul>
	Bad resolution of the display The system can handle the average laptop resolution of 3 Megapixel. However, up or down scaling on the meeting room display can cause visible artefacts.	Change the resolution on the web interface and match it to the native resolution of the meeting room display.
Users have a bad wireless connection. The connection from the Button to the Base Unit keeps falling away.	Wireless congestion	<ul style="list-style-type: none"> <li>• Use a WiFi scanner to find a free wireless channel and select it via the web interface. You can use commercial as well as free online tools such as inSSIDer or Xirrus for this. Refer to "WiFi settings".</li> </ul>
	Low signal strength	<ul style="list-style-type: none"> <li>• Put the Base Unit closer to the meeting room table.</li> <li>• Remove or limit as much as possible all obstructions between the Buttons and the Base Unit.</li> </ul>
Web interface is not accessible	Browser	<ul style="list-style-type: none"> <li>• Use another browser (version).</li> <li>• Check the browser settings.</li> </ul>
	No connection	<ul style="list-style-type: none"> <li>• There are three methods to access the web interface. Refer to the corresponding chapter of the documentation.</li> <li>• Check the proxy settings</li> </ul>
Users do not get a ClickShare drive when inserting the Button in their laptop.	<ul style="list-style-type: none"> <li>• No automatic refresh of drives</li> <li>• Windows tries to assign the ClickShare drive to an already reserved drive letter</li> </ul>	<ul style="list-style-type: none"> <li>• Refresh your view on the laptop.</li> <li>• Use Microsoft Windows Disk Management to assign it to a free drive letter.</li> </ul>
	Bad connection at USB port on the laptop	<ul style="list-style-type: none"> <li>• Reconnect to the USB port.</li> <li>• Try another USB port.</li> <li>• Reboot the laptop.</li> </ul>
	<ul style="list-style-type: none"> <li>• Some types of USB devices might be blocked as a company policy.</li> <li>• USB port settings on the laptop might limit the usage of high</li> </ul>	If possible, change the USB port policy on the laptop.

Problem	Cause	Solution
	power USB devices when on battery power.	
Low video performance	Laptop performance	<ul style="list-style-type: none"> <li>• Lower the screen resolution of the laptop.</li> <li>• Disable the hardware acceleration for video.</li> <li>• Use only a part of the display to show the video.</li> <li>• Right click ClickShare icon in system tray and click on Capture mode to toggle the current setting..</li> </ul>
	Wireless connectivity	See "Users have bad connectivity"
Video is not shown on screen	Player uses overlays	<ul style="list-style-type: none"> <li>• Disable the usage of overlays in the preferences of the video player.</li> <li>• video is protected by HDCP and cannot be captured by ClickShare.</li> </ul>
Some programs of Windows are not shown on the display	Use of overlays, 3D or hardware acceleration in the GPU	<ul style="list-style-type: none"> <li>• Disable overlays or hardware acceleration in the GPU.</li> <li>• Disable AeroGlass in Windows 7</li> <li>• Upgrade the Base Unit to the latest software version.</li> </ul>
When using Windows 7 the following message about the Windows Aero color scheme appears: "Windows has detected your computer's performance is slow. This could be because there are not enough resources to run the Windows Aero color scheme. To improve...".	ClickShare uses resources from the GPU. In combination with other programs which do so, Windows 7 sometimes shows this message suggesting to disable Aero to improve the performance of your laptop.	It is safe to ignore this message and choose 'Keep the current color scheme'.
Your screen is not shown on the display when pressing the Button	The number of shared video's on the screen is exceeded. When roomdock is used, only one participant can share his screen.	Click and hold the button for 2 seconds to use the Show me full screen function.
	The ClickShare software is not running.	Go to the ClickShare drive and run the software.
Your content is removed from the display and the LEDs on the button are blinking white	Connection to the Base Unit is lost.	ClickShare tries to restore the connection automatically. If it fails, the LEDs on the Button start blinking red. Unplug the Button from your laptop and try a new Button.
Nothing is shown on the displays at all.	The displays are switched off.	Switch on the displays.
	The display cable is not correctly connected	Insert the display cable to the display and the Base Unit.
	The display does not recognize or is not able to display the Base Unit output resolution.	Change the corresponding setting via the web interface.

<b>Problem</b>	<b>Cause</b>	<b>Solution</b>
	The Base Unit is in standby mode	Briefly push the standby button on the Base Unit or insert a Button and run the ClickShare software.
Bad WiFi connectivity	<p>Congestion of the wireless channel</p> <p>Metal cabinets, walls, construction elements, ... can cause reflections deteriorating the wireless signal.</p> <p>Obstructions between Buttons and Base Unit cause lowering of the wireless strength and quality.</p>	<p>Use wireless network scan tools to look for free or the least congested channels.</p> <p>Move the Base Unit to another place in the room.</p> <p>Avoid placing it inside cabinets, false ceiling, below the table, behind a wall, in another room, ....</p> <p>Check out the ClickShare White paper on WiFi See <a href="http://www.barco.com/clickshare">www.barco.com/clickshare</a>.</p>
Web Interface shows error in the processes "WiFi Access Point Daemon" and/or "DHCP Server"	Configuration file is corrupted	Browse to the Configuration tab on the Web Interface and press "Load Default Settings".
ClickShare Base Unit does not start up correctly	Configuration file is corrupted	Browse to the Configuration tab of the Web Interface and press "Load Default Settings".
No LAN connection with the Base Unit	Wrong IP address	<p>IP address is not within your LAN range.</p> <p>DHCP is not enabled.</p>
No WiFi connection with Base Unit	SSID not correct	Enter the correct SSID

Locate the problem you are experiencing in the table below and apply the solution.



# Index

## A

- API documentation 81
- API password 84
- API settings 81
- Audio setup 62

## B

- Base Unit
  - About 12
  - Display
    - Connection 27
  - Ethernet
    - Connection 27
  - First startup 28
    - No configuration 34
    - Preferred way 29
  - Installation
    - Methods 20
  - LAN
    - Connection 27
  - Power
    - Connection 28
  - Restart 86
  - Table mounting 20
  - Touch screen
    - Connection 27
- Basic workflow 17
- Blackboard 96
- Button
  - Pairing 44
  - Prepare 43
- Buttons 90
  - External access point
    - EAP-TLS 91
    - EAP-TTLS 93
    - PEAP 94
    - WPA2-PSK 95

## C

- C-5, C-10
  - About 8
- Calendar
  - Integration
    - XMS Cloud 37
- ClickShare API 81
  - Password 84
- Configuration
  - Wizard 54
- Configuration files 61
- Configurator 49
  - Access 51
- Configurator password 84
- Connecting
  - Base Unit
    - Display 27
    - Ethernet 27
    - LAN 27
    - Power 28
    - Touch screen 27

## D

- Date - time
  - Manually 87
- Date - Time
  - NTP server 89
  - Time server 89
- Desktop app 46
  - MSI installer 47
- Display setup 62

## E

- Energy savers 89
- Environment condition check 16
- Extension pack 44
- Extension Pack
  - Installer 45

**F**

- Factory defaults 100
- Firmware
  - Update 103–104
    - Base Unit 98
    - Button 98
- First startup
  - Base Unit 28
    - No configuration 34
    - Preferred way 29
- Full backup 61

**G**

- Getting started 15

**H**

- HTTP encryption 84

**I**

- Installation 19
  - Base Unit
    - Methods 20
  - Ceiling mounting
    - Base Unit 20
  - Network connected setup 24
    - Dedicated 25
    - Dual network 24
  - Network deployment
    - Requirements 23
  - Out-of-the-box 22
  - Table mounting
    - Base Unit 20
  - Wall mounting
    - Base Unit 20

**L**

- LAN settings 72
- LAN Settings
  - Wired authentication 74
    - EAP-TLS 75
    - EAP-TTLS 77
- Language 56
- Location name 56
- Log settings 99

**M**

- Meeting room name 56
- Mobile Device
  - Support 14
- Mobile devices 78

**O**

- Out-of-the-box 22

**P**

- Pairing
  - Button 44
- Passwords 84
- Peripherals 62
- Persnalisation
  - Personalized wallpaper 59
  - Wallpaper
    - Personalized 59
- Personalisation
  - Wallpaper 58
- Portable version 61
- Ports 23
- Prepare
  - Button 43
- PresentSense 80

**R**

- Registration
  - XMS Cloud 35

**S**

- Safety
  - Environment condition check 16
- Security
  - HTTP encryption 84
  - Recommandations 16
- Security level 82
- Services
  - Mobile devices 78
  - PresentSense 80
- SNMP 81
- Specifications 7
  - C-5, C-10 9
- Status information 86
- System
  - XMS 96

**T**

- Table mounting
  - Base Unit 20
- Troubleshoot
  - Diagnostics 101
  - Log settings 99
- Troubleshooting 105
  - Logging 100
- Troubleshooting list 106

**U**

- Update
  - Firmware
    - Base Unit 98
    - Button 98
- Upload configuration 61

**W**

- Wallpaper 58
  - Personalized 59
- WebUI password 84
- Welcome text 56
- Wi-Fi settings 63–64
  - Wireless client 66
    - EAP-TLS 67
    - EAP-TTLS 69
    - PEAP 70
    - WPA-PSK 71
- Windows
  - Certified driver 46

**X**

- XMS Cloud 96







R5900103 /06 | 2023-08-17

[www.barco.com](http://www.barco.com)