



Cisco UCS 5108 Server Chassis Installation Guide

First Published: June 10, 2009

Last Modified: January 28, 2016

Americas Headquarters

Cisco Systems, Inc.
170 West Tasman Drive
San Jose, CA 95134-1706
USA
<http://www.cisco.com>
Tel: 408 526-4000
800 553-NETS (6387)
Fax: 408 527-0883

THE SPECIFICATIONS AND INFORMATION REGARDING THE PRODUCTS IN THIS MANUAL ARE SUBJECT TO CHANGE WITHOUT NOTICE. ALL STATEMENTS, INFORMATION, AND RECOMMENDATIONS IN THIS MANUAL ARE BELIEVED TO BE ACCURATE BUT ARE PRESENTED WITHOUT WARRANTY OF ANY KIND, EXPRESS OR IMPLIED. USERS MUST TAKE FULL RESPONSIBILITY FOR THEIR APPLICATION OF ANY PRODUCTS.

THE SOFTWARE LICENSE AND LIMITED WARRANTY FOR THE ACCOMPANYING PRODUCT ARE SET FORTH IN THE INFORMATION PACKET THAT SHIPPED WITH THE PRODUCT AND ARE INCORPORATED HEREIN BY THIS REFERENCE. IF YOU ARE UNABLE TO LOCATE THE SOFTWARE LICENSE OR LIMITED WARRANTY, CONTACT YOUR CISCO REPRESENTATIVE FOR A COPY.

The following information is for FCC compliance of Class A devices: This equipment has been tested and found to comply with the limits for a Class A digital device, pursuant to part 15 of the FCC rules. These limits are designed to provide reasonable protection against harmful interference when the equipment is operated in a commercial environment. This equipment generates, uses, and can radiate radio-frequency energy and, if not installed and used in accordance with the instruction manual, may cause harmful interference to radio communications. Operation of this equipment in a residential area is likely to cause harmful interference, in which case users will be required to correct the interference at their own expense.

The following information is for FCC compliance of Class B devices: This equipment has been tested and found to comply with the limits for a Class B digital device, pursuant to part 15 of the FCC rules. These limits are designed to provide reasonable protection against harmful interference in a residential installation. This equipment generates, uses and can radiate radio frequency energy and, if not installed and used in accordance with the instructions, may cause harmful interference to radio communications. However, there is no guarantee that interference will not occur in a particular installation. If the equipment causes interference to radio or television reception, which can be determined by turning the equipment off and on, users are encouraged to try to correct the interference by using one or more of the following measures:

- Reorient or relocate the receiving antenna.
- Increase the separation between the equipment and receiver.
- Connect the equipment into an outlet on a circuit different from that to which the receiver is connected.
- Consult the dealer or an experienced radio/TV technician for help.

Modifications to this product not authorized by Cisco could void the FCC approval and negate your authority to operate the product

The Cisco implementation of TCP header compression is an adaptation of a program developed by the University of California, Berkeley (UCB) as part of UCB's public domain version of the UNIX operating system. All rights reserved. Copyright © 1981, Regents of the University of California.

NOTWITHSTANDING ANY OTHER WARRANTY HEREIN, ALL DOCUMENT FILES AND SOFTWARE OF THESE SUPPLIERS ARE PROVIDED "AS IS" WITH ALL FAULTS. CISCO AND THE ABOVE-NAMED SUPPLIERS DISCLAIM ALL WARRANTIES, EXPRESSED OR IMPLIED, INCLUDING, WITHOUT LIMITATION, THOSE OF MERCHANTABILITY, FITNESS FOR A PARTICULAR PURPOSE AND NONINFRINGEMENT OR ARISING FROM A COURSE OF DEALING, USAGE, OR TRADE PRACTICE.

IN NO EVENT SHALL CISCO OR ITS SUPPLIERS BE LIABLE FOR ANY INDIRECT, SPECIAL, CONSEQUENTIAL, OR INCIDENTAL DAMAGES, INCLUDING, WITHOUT LIMITATION, LOST PROFITS OR LOSS OR DAMAGE TO DATA ARISING OUT OF THE USE OR INABILITY TO USE THIS MANUAL, EVEN IF CISCO OR ITS SUPPLIERS HAVE BEEN ADVISED OF THE POSSIBILITY OF SUCH DAMAGES.

Any Internet Protocol (IP) addresses and phone numbers used in this document are not intended to be actual addresses and phone numbers. Any examples, command display output, network topology diagrams, and other figures included in the document are shown for illustrative purposes only. Any use of actual IP addresses or phone numbers in illustrative content is unintentional and coincidental.

Cisco and the Cisco logo are trademarks or registered trademarks of Cisco and/or its affiliates in the U.S. and other countries. To view a list of Cisco trademarks, go to this URL: <http://www.cisco.com/go/trademarks>. Third-party trademarks mentioned are the property of their respective owners. The use of the word partner does not imply a partnership relationship between Cisco and any other company. (1110R)

© 2009-2016 Cisco Systems, Inc. All rights reserved.



CONTENTS

Preface

Preface ix

Audience ix

Conventions ix

Related Cisco UCS Documentation xi

Obtaining Documentation and Submitting a Service Request xi

CHAPTER 1

Overview 1

System Overview 1

Features and Benefits 3

Components 4

Cisco UCS 5108 Server Chassis 4

LEDs 5

Buttons 5

Connectors 5

Midplane 5

Blade Servers 5

Cisco UCS B200 Blade Servers 6

LEDs 7

Buttons 7

Connectors 7

Cisco UCS B200 M3 Blade Servers 7

LEDs 8

Buttons 8

Connectors 8

Cisco UCS B200 M4 Blade Server 8

LEDs 9

Buttons 9

Connectors	9
Cisco UCS B22 M3 Blade Servers	10
LEDs	10
Buttons	10
Connectors	11
Cisco UCS B230 Blade Servers	11
LEDs	12
Buttons	12
Connectors	12
Cisco UCS B250 Blade Servers	12
LEDs	13
Buttons	13
Connectors	13
Cisco UCS B440 Blade Servers	13
LEDs	14
Buttons	14
Connectors	14
Cisco UCS B420 M3 High Performance Blade Server	15
LEDs	15
Buttons	15
Connectors	16
Cisco UCS B420 M4 Blade Server	16
LEDs	17
Buttons	17
Connectors	17
Cisco UCS B260 M4 Scalable Blade Server	17
LEDs	18
Buttons	18
Connectors	18
Cisco UCS B460 M4 Blade Server	19
LEDs	19
Buttons	19
Connectors	20
Adapter Cards	20
Cisco UCS Virtual Interface Card 1240	20

Cisco UCS Virtual Interface Card 1280	20
Cisco UCS M81KR Virtual Interface Card	20
Cisco UCS 82598KR-CI 10 Gigabit Ethernet Adapter	21
Cisco UCS M71KR-E Emulex Converged Network Adapter	21
Cisco UCS M71KR-Q QLogic Converged Network Adapter	22
Cisco UCS 6324 Fabric Interconnect	23
Cisco UCS 2304 IOM	24
LEDs	26
Buttons	26
Connectors	26
Cisco UCS 2200 Series FEXes	26
LEDs	28
Buttons	28
Connectors	28
Cisco UCS 2104XP FEXes	29
LEDs	30
Buttons	30
Connectors	30
Power Distribution Unit (PDU)	30
LEDs	30
Buttons	30
Connectors	30
Fan Modules	31
LEDs	31
Buttons and Connectors	31
Power Supplies	31
LEDs	31
Buttons	31
Connectors	31
Power Supply Redundancy	32
Non-redundant Mode	32
N+1 Redundancy	32
Grid Redundancy	33
LEDs	34
LED Locations	35

Interpreting LEDs 36

CHAPTER 2**Installation 41**

Installation Notes and Warnings for the Cisco UCS 5108 Server Chassis 41

Rack Requirements 42

Cable Management 42

Airflow Considerations 43

Moving Server Chassis 43

Installation Guidelines 44

Required Equipment 45

Unpacking and Inspecting the Chassis 45

Attaching the Round Hole Adapter Kit to the Rails (Optional) 46

Installing the Chassis 46

Installing the Rails 48

Installing the Round Hole Adapter Kit 51

Inserting the Chassis into the Rack 52

Connecting a DC Power Supply 54

Required Tools 54

DC Power Installation Procedure 54

Cabling Considerations for Fabric Port Channels 57

Proper FEX and Fabric Interconnect Port Connectivity 58

Removing the Chassis from a Rack 60

Repacking the Chassis 60

SFP+ Transceivers 60

SFP+ Twinax Copper Transceivers 60

Optical SFP+ Transceivers 61

SFP and SFP+ Transceivers for the UCS 6324 Fabric Interconnect 62

Twinax Copper Cables for the UCS 6324 Fabric Interconnect 63

QSFP+ Copper Optical Transceivers for the UCS 6324 Fabric Interconnect 63

Replacing a Copper Twinax SFP+ Transceiver with an Optical SFP+ Transceiver 64

CHAPTER 3**Installing and Removing Components 67**

Components 67

Installing and Removing a Blade Server 69

Installing and Removing a Blade Server Hard Drive 69

Installing a Blade Server Hard Drive	70
Removing a Blade Server Hard Drive	71
Installing and Removing Power Supplies	71
Installing a Power Supply	72
Removing a Power Supply	73
Installing and Removing a Power Distribution Unit (PDU)	73
Installing a PDU	74
Removing a PDU	74
Installing and Removing a FEX or Fabric Interconnect	75
UCS 2104 to UCS 2200 Series FEX Upgrade Considerations	75
Removing a FEX or UCS 6324 Fabric Interconnect	76
Installing a FEX or Fabric Interconnect	76
Migrating to UCS 6300 Series Fabric Interconnects and the UCS 2304 IOM	77
Migrating Fabric Interconnect Modules	77
Migrating IO Modules	79
Migrating FEX Modules	79
Installing and Removing a Fan Module	80
Installing a Fan Module	80
Removing a Fan Module	81

APPENDIX A

Technical Specifications	83
KVM Cable	83
Chassis Specifications	84
Environmental Specifications	85
Environmental Conditions and Power Requirement Specifications for Twinax SFP+ Transceivers	85
Specifications for the Cisco UCS 5108 Blade Server Chassis Power Supply Units	86
Supported AC Power Cords and Plugs	89
Australia and New Zealand	90
Continental Europe	90
International	90
Israel	91
Japan and North America	91
Peoples Republic of China	92
Switzerland	93

Power Distribution Unit (PDU) 93

APPENDIX B

Site Planning and Maintenance Records 95

Site Preparation Checklist 95

Contact and Site Information 97

Chassis and Module Information 97

FEX Port Connection Record 99

UCS 6324 Fabric Interconnect Port Connection Record 100



Preface

- [Audience, page ix](#)
- [Conventions, page ix](#)
- [Related Cisco UCS Documentation, page xi](#)
- [Obtaining Documentation and Submitting a Service Request, page xi](#)

Audience

To use this installation guide, you must be familiar with electronic circuitry and wiring practices and preferably be an electronic or electromechanical technician who has experience with electronic and electromechanical equipment.

Only trained and qualified service personnel (as defined in IEC 60950-1 and AS/NZS60950) should install, replace, or service the equipment. Install the system in accordance with the U.S. National Electric Code if you are in the United States.

Conventions

Text Type	Indication
GUI elements	GUI elements such as tab titles, area names, and field labels appear in this font . Main titles such as window, dialog box, and wizard titles appear in this font .
Document titles	Document titles appear in <i>this font</i> .
TUI elements	In a Text-based User Interface, text the system displays appears in <code>this font</code> .
System output	Terminal sessions and information that the system displays appear in <code>this font</code> .
CLI commands	CLI command keywords appear in this font . Variables in a CLI command appear in <i>this font</i> .

Text Type	Indication
[]	Elements in square brackets are optional.
{x y z}	Required alternative keywords are grouped in braces and separated by vertical bars.
[x y z]	Optional alternative keywords are grouped in brackets and separated by vertical bars.
string	A nonquoted set of characters. Do not use quotation marks around the string or the string will include the quotation marks.
<>	Nonprinting characters such as passwords are in angle brackets.
[]	Default responses to system prompts are in square brackets.
!, #	An exclamation point (!) or a pound sign (#) at the beginning of a line of code indicates a comment line.

**Note**

Means *reader take note*. Notes contain helpful suggestions or references to material not covered in the document.

**Tip**

Means *the following information will help you solve a problem*. The tips information might not be troubleshooting or even an action, but could be useful information, similar to a Timesaver.

**Caution**

Means *reader be careful*. In this situation, you might perform an action that could result in equipment damage or loss of data.

**Timesaver**

Means *the described action saves time*. You can save time by performing the action described in the paragraph.

**Warning****IMPORTANT SAFETY INSTRUCTIONS**

This warning symbol means danger. You are in a situation that could cause bodily injury. Before you work on any equipment, be aware of the hazards involved with electrical circuitry and be familiar with standard practices for preventing accidents. Use the statement number provided at the end of each warning to locate its translation in the translated safety warnings that accompanied this device.

SAVE THESE INSTRUCTIONS

Related Cisco UCS Documentation

Documentation Roadmaps

For a complete list of all B-Series documentation, see the *Cisco UCS B-Series Servers Documentation Roadmap* available at the following URL: <http://www.cisco.com/go/unifiedcomputing/b-series-doc>.

For a complete list of all C-Series documentation, see the *Cisco UCS C-Series Servers Documentation Roadmap* available at the following URL: <http://www.cisco.com/go/unifiedcomputing/c-series-doc>.

For information on supported firmware versions and supported UCS Manager versions for the rack servers that are integrated with the UCS Manager for management, refer to [Release Bundle Contents for Cisco UCS Software](#).

Other Documentation Resources

Follow [Cisco UCS Docs on Twitter](#) to receive document update notifications.

Obtaining Documentation and Submitting a Service Request

For information on obtaining documentation, submitting a service request, and gathering additional information, see the monthly [What's New in Cisco Product Documentation](#), which also lists all new and revised Cisco technical documentation.

Subscribe to the *What's New in Cisco Product Documentation* as a Really Simple Syndication (RSS) feed and set content to be delivered directly to your desktop using a reader application. The RSS feeds are a free service and Cisco currently supports RSS version 2.0.

Follow [Cisco UCS Docs on Twitter](#) to receive document update notifications.



CHAPTER 1

Overview

This chapter contains the following sections:

- [System Overview, page 1](#)
- [Features and Benefits, page 3](#)
- [Components, page 4](#)
- [LEDs, page 34](#)

System Overview

The Cisco UCS 5108 server chassis and its components are part of the Cisco Unified Computing System (UCS), which uses the Cisco UCS 5108 server system with the two I/O modules and the Cisco UCS Fabric Interconnects to provide advanced options and capabilities in server and data management. All servers are managed via the GUI or CLI with Cisco UCS Manager.

The Cisco UCS 5108 server chassis system consists of the following components:

- Cisco UCS 5108 server chassis—AC version (UCSB-5108-AC2 and N20-C6508)
- Cisco UCS 5108 server chassis—DC version (UCSB-5108-DC2 and UCSB-5108-DC)
- Cisco UCS 2104XP I/O Module (N20-I6584)—Up to two I/O modules, each providing four ports of 10-Gb Ethernet, Cisco Data Center Ethernet, and Fibre Channel over Ethernet (FCoE) connection to the fabric interconnect
- Cisco UCS 2208XP I/O Module (UCS-IOM-2208XP)—Up to two I/O modules, each providing eight universal ports configurable as a 10-Gb Ethernet, Cisco Data Center Ethernet, or Fibre Channel over Ethernet (FCoE) connection to the fabric interconnect
- Cisco UCS 2204XP I/O Module (UCS-IOM-2204XP)—Up to two I/O modules, each providing four universal ports configurable as a 10-Gb Ethernet, Cisco Data Center Ethernet, or Fibre Channel over Ethernet (FCoE) connection to the fabric interconnect
- Cisco UCS 2304 I/O Module (UCS-IOM-2304)—Up to two I/O modules, each with 4 configurable 40-Gigabit uplink ports and 8 40-Gigabit backplane ports
- A number of SFP+ choices using copper or optical fiber

- Power supplies (N20-PAC5-2500W, UCSB-PSU-2500ACPL or UCSB-PSU-2500DC48)—Up to four 2500 Watt hot-swappable power supplies
- Fan modules (N20-FAN5)—Eight hot-swappable fan modules
- UCS B-series blade servers, including
 - Cisco UCS B200 blade servers (N20-B6620-1 for M1 or N20-B6625-1 for M2)—Up to eight half-width blade servers, each containing two CPUs and holding up to two hard drives capable of RAID 0 or 1
 - Cisco UCS B200 M3 blade servers (UCSB-B200-M3)—Up to eight half-width blade servers, each containing two CPUs and holding up to two hard drives capable of RAID 0 or 1
 - Cisco UCS B200 M4 blade servers (UCSB-B200-M4)—Up to eight half-width blade servers, each containing two CPUs and holding up to two hard drives capable of RAID 0 or 1
 - Cisco UCS B22 blade servers (UCSB-B22-M3)—Up to eight half-width blade servers, each containing two CPUs and holding up to two hard drives capable of RAID 0 or 1
 - Cisco UCS B230 blade servers (N20-B6730)—Up to eight half-width blade servers, each containing two CPUs and holding up to two SSD drives capable of RAID 0 or 1
 - Cisco UCS B250 blade servers (N20-B6620-2 for M1 or N20-B6625-2 for M2)—Up to four full-width blade servers, each containing two CPUs and holding up to two hard drives capable of RAID 0 or 1
 - Cisco UCS B440 blade servers (N20-B6740-2)—Up to four full-width blade servers, each containing four CPUs and holding up to four hard drives capable of RAID 0, 1, 5, and 6
 - Cisco UCS B420 blade servers (UCSB-B420-M3)—Up to four full-width blade servers, each containing four CPUs and holding up to four hard drives capable of RAID 0, 1, 5, and 10
 - Cisco UCS B260 M4 blade servers (UCSB-EX-M4-1 or UCSB-EX-M4-2)—Up to four full-width blade servers, each containing two CPUs and a SAS RAID controller
 - Cisco UCS B460 M4 blade servers (UCSB-EX-M4-1 or UCSB-EX-M4-2)—Up to two full-width blade servers, each containing four CPUs and SAS RAID controllers

For smaller solutions, the Cisco UCS 6324 Fabric Interconnect can be used in the I/O slots at the back of the Cisco UCS 5108 Chassis. The 6324 Fabric Interconnect is only supported in the UCSB-5108-AC2 and UCSB-5108-DC2 versions of the 5100 Series Chassis.

UCS Mini, which is a smaller solution, consists of the following components:

- Cisco UCS 5108 server chassis—AC version (UCSB-5108-AC2)
- Cisco UCS 5108 server chassis—DC version (UCSB-5108-DC2)
- Cisco UCS 6324 Fabric Interconnect for the UCS Mini system (UCS-FI-M-6324)—Up to two integrated fabric interconnect modules, each providing four SFP+ ports of 10-Gigabit Ethernet and Fibre Channel over Ethernet (FCoE), and a QSFP+ port
- A number of SFP+ choices using copper or optical fiber
- Power supplies (UCSB-PSU-2500ACDV, UCSB-PSU-2500DC48, and UCSB-PSU-2500HVDC)—Up to four 2500 Watt, hot-swappable power supplies
- Fan modules (N20-FAN5)—Eight hot-swappable fan modules

- UCS B-Series blade servers, including the following:
 - Cisco UCS B200 M3 blade servers (UCSB-B200-M3)—Up to eight half-width blade servers, each containing two CPUs and holding up to two hard drives capable of RAID 0 or 1
- UCS C-Series rack servers, including the following:
 - Cisco UCS C240 M3 rack servers (UCSC-C240-M3) and Cisco UCS C220 M3 rack servers—Up to seven rack servers, either C240 M3 or C220 M3 or a combination of the two.

Features and Benefits

The Cisco UCS 5108 server chassis revolutionizes the use and deployment of blade-based systems. By incorporating unified fabric, integrated, embedded management, and fabric extender technology, the Cisco Unified Computing System enables the chassis to have fewer physical components, no independent management, and to be more energy efficient than traditional blade server chassis.

This simplicity eliminates the need for dedicated chassis management and blade switches, reduces cabling, and enables the Cisco Unified Computing System to scale to 40 chassis without adding complexity. The Cisco UCS 5108 server chassis is a critical component in delivering the Cisco Unified Computing System benefits of data center simplicity and IT responsiveness.

Table 1: Features and Benefits

Feature	Benefit
Management by Cisco UCS Manager	Reduces total cost of ownership by removing management modules from the chassis, making the chassis stateless. Provides a single, highly available management domain for all system chassis, reducing administrative tasks.
Unified fabric	Decreases TCO by reducing the number of network interface cards (NICs), host bus adapters (HBAs), switches, and cables needed.
Support for one or two Cisco UCS 2100 Series or Cisco UCS 2200 FEXes or UCS 2304 IOM, and support for one or two Cisco UCS 6324 Fabric Interconnects in the UCS Mini chassis	Eliminates switches from the chassis, including the complex configuration and management of those switches, allowing a system to scale without adding complexity and cost. Allows use of two I/O modules for redundancy or aggregation of bandwidth. Enables bandwidth scaling based on application needs; blades can be configured from 1.25 Gbps to 40 Gbps or more.
Auto discovery	Requires no configuration; like all components in the Cisco Unified Computing System, chassis are automatically recognized and configured by Cisco UCS Manager.

Feature	Benefit
High-performance midplane	Provides investment protection for new fabric extenders and future blade servers. Supports up to 2x 40 Gigabit Ethernet for every blade server slot. Provides 8 blades with 1.2 Tbps of available Ethernet throughput for future I/O requirements. The Cisco UCS 6324 Fabric Interconnect supports only 512 Gbps. Provides reconfigurable chassis to accommodate a variety of form factors and functions.
Redundant hot swappable power supplies and fans	Provides high availability in multiple configurations. Increases serviceability. Provides uninterrupted service during maintenance. Available configured for AC or DC environments (mixing not supported)
Hot-pluggable blade servers, FEXes, and fabric interconnects	Provides uninterrupted service during maintenance and server deployment.
Comprehensive monitoring	Provides extensive environmental monitoring on each chassis Allows use of user thresholds to optimize environmental management of the chassis.
Efficient front-to-back airflow	Helps reduce power consumption and increase component reliability.
Tool-free installation	Requires no specialized tools for chassis installation. Provides mounting rails for easy installation and servicing.
Mixed blade configurations	Allows up to 8 half-width or 4 full-width blade servers, or any combination thereof, for outstanding flexibility. When configured with the 6324 Fabric Interconnect, only 8 half-width B200 M3 blades are supported.

Components

Cisco UCS 5108 Server Chassis

The Cisco UCS 5100 Series Blade Server Chassis is a scalable and flexible blade server chassis for today's and tomorrow's data center that helps reduce total cost of ownership. There are two versions available that can be configured for AC (N20-C6508 and UCSB-5108-AC2) and two versions that can be configured for DC (UCSB-5108-DC and UCSB-5108-DC2) power environments. An additional version (UCSB-5108-HVDC) is available that can be configured for 200 - 380V DC environments.

Is six rack units (6 RU) high and can mount in an industry-standard 19-inch rack with square holes (such as the Cisco R Series Racks) or in round hole racks when an adapter is used. The chassis can house up to eight

half-width Cisco UCS B-Series Blade Servers and can accommodate both half- and full-width blade form factors.

Up to four hot-swappable AC, DC or HVDC power supplies are accessible from the front of the chassis. These power supplies can be configured to support nonredundant, N+1 redundant, and grid-redundant configurations. The rear of the chassis contains eight hot-swappable fans, four power connectors (one per power supply), and two I/O bays for I/O modules. A passive backplane provides support for up to 80 Gbps of I/O bandwidth to each half-width blade and 160 Gbps of I/O bandwidth to each full width-blade.

Scalability is dependent on both hardware and software. For more information, see [UCS 2104 to UCS 2200 Series FEX Upgrade Considerations, on page 75](#) and the appropriate [UCS software release notes](#).

LEDs

LEDs on the chassis indicate system connectivity and failure warnings. See [LED Locations, on page 35](#) for details. There is also a flashing blue Beaconing LED and button that can be triggered manually or remotely from UCS Manager.

Buttons

The beaconing function LED is also a feature on/off button. When triggered, beaconing of the server chassis is observable remotely from UCS Manager.

Connectors

There are no user connectors such as RJ-45 ports on the chassis itself.

Midplane

The integral chassis midplane supports the following:

- 320 G total bandwidth to each of two I/O Modules
- Auto-discover of all components
- Redundant data and management paths
- 10 G Base-KR

The midplane is an entirely passive device.

Blade Servers

The Cisco UCS B-Series Blade Servers are based on industry-standard server technologies and provide the following:

- Up to two or four Intel multi-core processors, depending on the server
- Front-accessible, hot-swappable hard drives or solid-state disk (SSD) drives
- Depending on the server, support is available for up to three adapter card connections for up to 160 Gbps of redundant I/O throughput

- Industry-standard double-data-rate 3 (DDR3) memory
- Remote management through an integrated service processor that also executes policy established in Cisco UCS Manager software
- Local keyboard, video, and mouse (KVM) and serial console access through a front console port on each server
- Out-of-band access by remote KVM, Secure Shell (SSH), and virtual media (vMedia) as well as Intelligent Platform Management Interface (IPMI)

The Cisco UCS B-Series offers multiple blade server models. The supported processor family is indicated by M1, M2, M3, or M4 designations on the model.

Cisco UCS B200 Blade Servers

For full service and installation instructions, see the [Cisco UCS B200 Blade Server Installation and Service Note](#). You can install up to eight UCS B200 M1 or M2 Blade Servers to a chassis.

Figure 1: Cisco UCS B200 M1 and M2

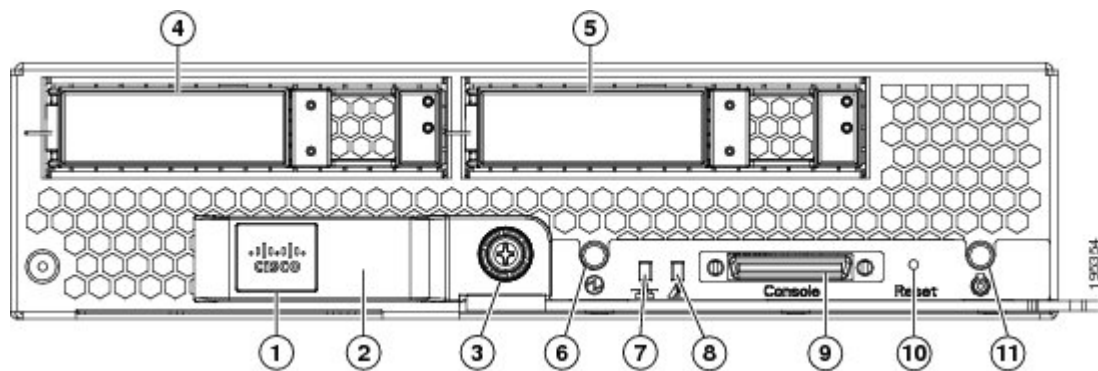

1	Paper tab for server name or serial numbers	7	Network link status LED
2	Blade ejector handle	8	Blade health LED
3	Ejector captive screw	9	Console connector
4	Hard drive bay 1	10	Reset button access
5	Hard drive bay 2	11	Beaconing LED and button
6	Power button and LED		

LEDs

The LED indicators indicate whether the blade server is in active or standby mode, the status of the network link, the over all health of the blade server, and whether the server is set to give a flashing blue beaconing indication. See [Interpreting LEDs, on page 36](#) for details.

The removable hard disks also have LEDs indicating hard disk access activity and hard disk health.

Buttons

The Reset button is just inside the chassis and must be pressed using the tip of a paper clip or a similar item. Hold the button down for five seconds and then release it to restart the server if other methods of restarting are not working.

The beaconing function for an individual server may get turned on or off by pressing the combination button and LED. See [Interpreting LEDs, on page 36](#) for details.

The power button and LED allows you to manually take a server temporarily out of service but leave it in a state where it can be restarted quickly.

Connectors

A console port gives a direct connection to a blade server to allow operating system installation and other management tasks to be done directly rather than remotely. The port uses the KVM dongle device included in the chassis accessory kit. See [KVM Cable, on page 83](#) for more information.

Cisco UCS B200 M3 Blade Servers

For full service and installation instructions, see the [Cisco UCS B200 M3 Blade Server Installation and Service Note](#). You can install up to eight UCS B200 M3 Blade Servers to a chassis.

Figure 2: Cisco UCS B200 M3

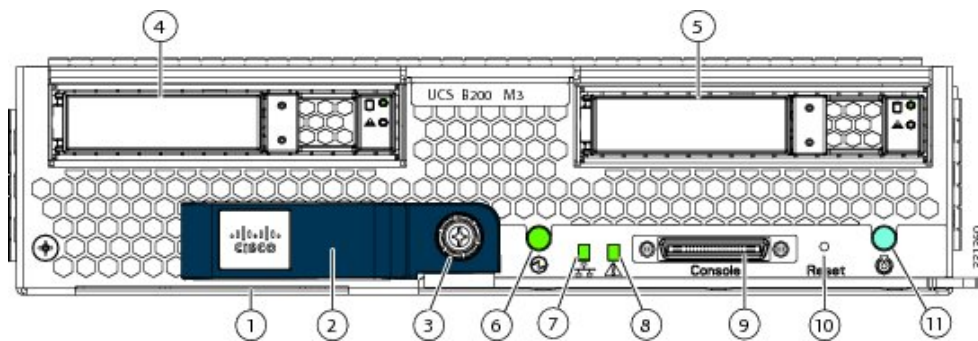

1	Asset Tag ¹	7	Network link status LED
2	Blade ejector handle	8	Blade health LED
3	Ejector captive screw	9	Console connector

4	Hard drive bay 1	10	Reset button access
5	Hard drive bay 2	11	Beaconing LED and button
6	Power button and LED		

¹ Each server has a blank plastic tag that pulls out of the front panel which is provided so that you can add your own asset tracking label without interfering with the intended air flow.

LEDs

The LED indicators indicate whether the blade server is in active or standby mode, the status of the network link, the overall health of the blade server, and whether the server is set to give a flashing blue beaconing indication. See [Interpreting LEDs, on page 36](#) for details.

The removable hard disks also have LEDs indicating hard disk access activity and hard disk health.

Buttons

The Reset button is just inside the chassis and must be pressed using the tip of a paper clip or a similar item. Hold the button down for five seconds and then release it to restart the server if other methods of restarting are not working.

The beaconing function for an individual server may get turned on or off by pressing the combination button and LED. See [Interpreting LEDs, on page 36](#) for details.

The power button and LED allows you to manually take a server temporarily out of service but leave it in a state where it can be restarted quickly.

Connectors

A console port gives a direct connection to a blade server to allow operating system installation and other management tasks to be done directly rather than remotely. The port uses the KVM dongle device included in the chassis accessory kit. See [KVM Cable, on page 83](#) for more information.

Cisco UCS B200 M4 Blade Server

For full service and installation instructions, see the [Cisco UCS B200 M4 Blade Server Installation and Service Note](#). You can install up to eight UCS B200 M4 Blade Servers in a chassis.

Figure 3: Cisco UCS B200 M4 Front Panel

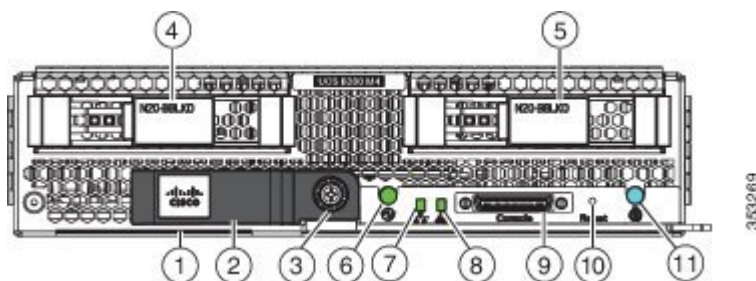

1	Asset pull tag Each server has a blank plastic tag that pulls out of the front panel which is provided so that you can add your own asset tracking label without interfering with the intended air flow.	2	Blade ejector handle
3	Ejector captive screw	4	Hard drive bay 1
5	Hard drive bay 2	6	Power button and LED
7	Network link status LED	8	Blade health LED
9	Local console connector	10	Reset button access
11	Locator button and LED		

LEDs

The LED indicators indicate whether the blade server is in active or standby mode, the status of the network link, the over all health of the blade server, and whether the server is set to give a flashing blue beaconing indication. See [Interpreting LEDs, on page 36](#) for details.

The removable hard disks also have LEDs indicating hard disk access activity and hard disk health.

Buttons

The Reset button is just inside the chassis and must be pressed using the tip of a paper clip or a similar item. Hold the button down for five seconds and then release it to restart the server if other methods of restarting are not working.

The beaconing function for an individual server may get turned on or off by pressing the combination button and LED. See [Interpreting LEDs, on page 36](#) for details.

The power button and LED allows you to manually take a server temporarily out of service but leave it in a state where it can be restarted quickly.

Connectors

A console port gives a direct connection to a blade server to allow operating system installation and other management tasks to be done directly rather than remotely. The port uses the KVM dongle device included in the chassis accessory kit. See [KVM Cable, on page 83](#) for more information.

Cisco UCS B22 M3 Blade Servers

For full service and installation instructions, see the [Cisco UCS B22 Blade Server Installation and Service Note](#). You can install up to eight UCS B22 M3 Blade Servers to a chassis.

Figure 4: Cisco UCS B22 M3

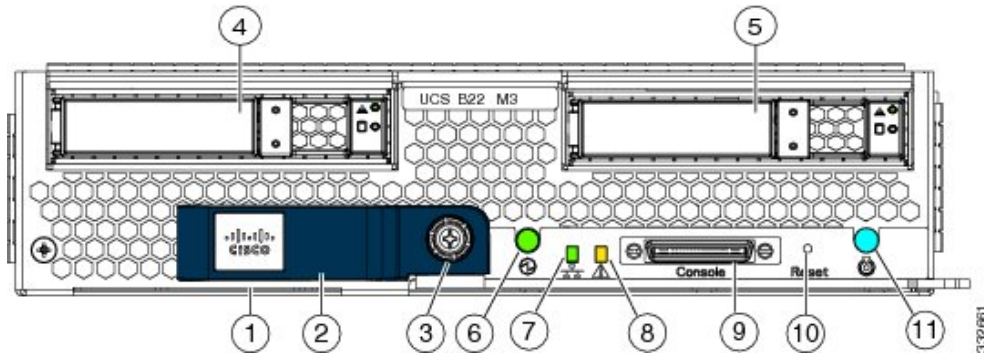

1	Asset tag ²	7	Network link status LED
2	Blade ejector handle	8	Blade health LED
3	Ejector captive screw	9	Console connector
4	Hard drive bay 1	10	Reset button access
5	Hard drive bay 2	11	Beaoning LED and button
6	Power button and LED		

² Each server has a blank plastic asset tag that pulls out of the front panel, provided so you can add your own asset tracking label without interfering with the intended air flow.

LEDs

The LED indicators indicate whether the blade server is in active or standby mode, the status of the network link, the over all health of the blade server, and whether the server is set to give a flashing blue beaoning indication. See [Interpreting LEDs, on page 36](#) for details.

The removable hard disks also have LEDs indicating hard disk access activity and hard disk health.

Buttons

The Reset button is just inside the chassis and must be pressed using the tip of a paper clip or a similar item. Hold the button down for five seconds and then release it to restart the server if other methods of restarting are not working.

The beaoning function for an individual server may get turned on or off by pressing the combination button and LED. See [Interpreting LEDs, on page 36](#) for details.

The power button and LED allows you to manually take a server temporarily out of service but leave it in a state where it can be restarted quickly.

Connectors

A console port gives a direct connection to a blade server to allow operating system installation and other management tasks to be done directly rather than remotely. The port uses the KVM dongle device included in the chassis accessory kit. See [KVM Cable](#), on page 83 for more information.

Cisco UCS B230 Blade Servers

For full service and installation instructions, see the [Cisco UCS B230 Blade Server Installation and Service Note](#). You can install up to eight UCS B230 Blade Servers to a chassis.

Figure 5: Cisco UCS B230 (N20-B6730) Front Panel

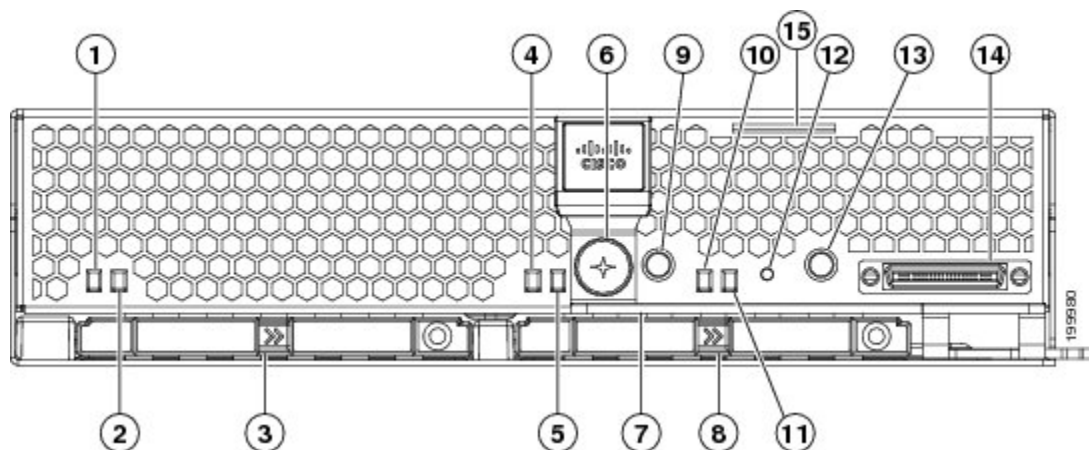

1	SSD 1 Activity LED	9	Beaconing LED and button
2	SSD 1 Fault/Locate LED	10	System Activity LED
3	SSD sled in Bay 1	11	Blade health LED
4	SSD 2 Activity	12	Reset button access
5	SSD 2 Fault LED	13	Power button and LED
6	Ejector lever captive screw	14	Console connector
7	Ejector lever	15	Asset tag
8	SSD sled in Bay 1		

LEDs

The LED indicators indicate whether the blade server is in active or standby mode, the status of the network link, the overall health of the blade server, and whether the server is set to give a flashing blue beaconing indication. See [Interpreting LEDs, on page 36](#) for details.

The removable hard disks also have LEDs indicating hard disk access activity and hard disk health.

Buttons

The Reset button is just inside the chassis and must be pressed using the tip of a paper clip or a similar item. Hold the button down for five seconds and then release it to restart the server if other methods of restarting are not working.

The beaconing function for an individual server may get turned on or off by pressing the combination button and LED. See [Interpreting LEDs, on page 36](#) for details.

The power button and LED allows you to manually take a server temporarily out of service but leave it in a state where it can be restarted quickly.

Connectors

A console port gives a direct connection to a blade server to allow operating system installation and other management tasks to be done directly rather than remotely. The port uses the KVM dongle device included in the chassis accessory kit. See [KVM Cable, on page 83](#) for more information.

Cisco UCS B250 Blade Servers

For full service and installation instructions, see the [Cisco UCS B250 Blade Server Installation and Service Note](#).

Figure 6: Cisco UCS B250

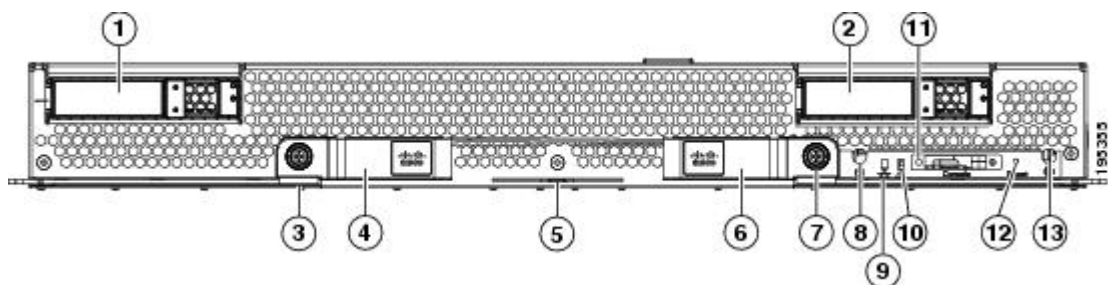

1	Hard drive bay 1	8	Power button and LED
2	Hard drive bay 2	9	Network link status LED
3	Left ejector captive screw	10	Blade health LED
4	Left blade ejector handle	11	Console connector

5	Paper tab for server name or serial numbers	12	Reset button access
6	Right blade ejector handle	13	Beaconing LED and button
7	Right ejector captive screw		

LEDs

The LED indicators indicate whether the blade server is in active or standby mode, the status of the network link, the over all health of the blade server, and whether the server is set to give a flashing blue beaconing indication. See [Interpreting LEDs, on page 36](#) for details.

The removable hard disks also have LEDs indicating hard disk access activity and hard disk health.

Buttons

The Reset button is just inside the chassis and must be pressed using the tip of a paper clip or a similar item. Hold the button down for five seconds and then release it to restart the server if other methods of restarting are not working.

The beaconing function for an individual server may get turned on or off by pressing the combination button and LED. See [Interpreting LEDs, on page 36](#) for details.

The power button and LED allows you to manually take a server temporarily out of service but leave it in a state where it can be restarted quickly.

Connectors

A console port gives a direct connection to a blade server to allow operating system installation and other management tasks to be done directly rather than remotely. The port uses the KVM dongle device included in the chassis accessory kit. See [KVM Cable, on page 83](#) for more information.

Cisco UCS B440 Blade Servers

For full service and installation instructions, see the [Cisco UCS B440 High Performance Blade Server Installation and Service Note](#).

Figure 7: Cisco UCS B440

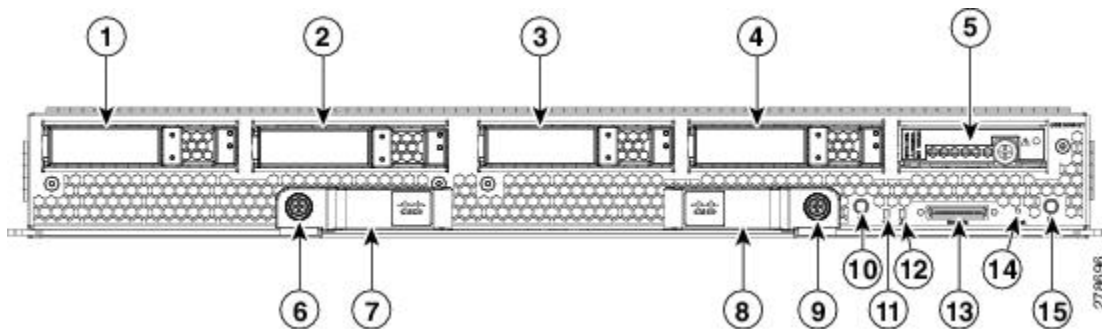

1	Hard drive bay 1	9	Right ejector thumbscrew
2	Hard drive bay 2	10	Power button and LED
3	Hard drive bay 3	11	Network link status LED
4	Hard drive bay 4	12	Blade health LED
5	RAID battery backup module (BBU)	13	Local console connection
6	Left ejector thumbscrew	14	Reset button access
7	Left ejector handle	15	Locate button and LED
8	Right ejector handle		

LEDs

The LED indicators indicate whether the blade server is in active or standby mode, the status of the network link, the over all health of the blade server, and whether the server is set to give a flashing blue beaconing indication. See [Interpreting LEDs, on page 36](#) for details.

The removable hard disks also have LEDs indicating hard disk access activity and hard disk health.

Buttons

The Reset button is just inside the chassis and must be pressed using the tip of a paper clip or a similar item. Hold the button down for five seconds and then release it to restart the server if other methods of restarting are not working.

The beaconing function for an individual server may get turned on or off by pressing the combination button and LED. See [Interpreting LEDs, on page 36](#) for details.

The power button and LED allows you to manually take a server temporarily out of service but leave it in a state where it can be restarted quickly.

Connectors

A console port gives a direct connection to a blade server to allow operating system installation and other management tasks to be done directly rather than remotely. The port uses the KVM dongle device included in the chassis accessory kit. See [KVM Cable, on page 83](#) for more information.

Cisco UCS B420 M3 High Performance Blade Server

For full service and installation instructions, see the [Cisco UCS B420 M3 High Performance Blade Server Installation and Service Note](#). You can install up to four UCS B420 M3 High Performance Blade Servers to a chassis.

Figure 8: Cisco UCS B420 M3

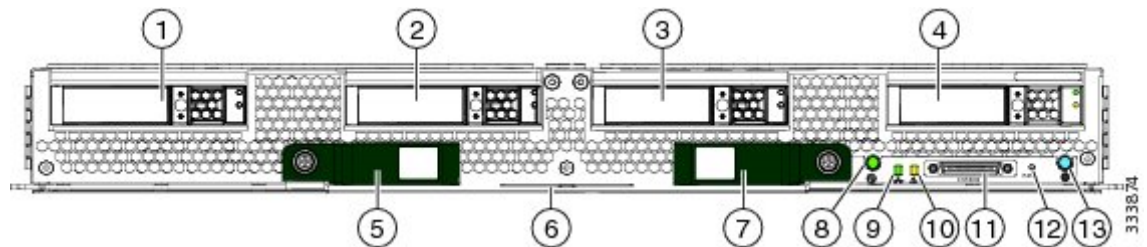

1	Hard drive bay 1	8	Power button and LED
2	Hard drive bay 2	9	Network link status LED
3	Hard drive bay 3	10	Blade health LED
4	Hard drive bay 4	11	Console connector
5	Left ejector handle	12	Reset button access
6	Asset tag ³	13	Beaconing LED and button
7	Right ejector handle		

³ Each server has a blank plastic asset tag that pulls out of the front panel, provided so you can add your own asset tracking label without interfering with the intended air flow.

LEDs

The LED indicators indicate whether the blade server is in active or standby mode, the status of the network link, the over all health of the blade server, and whether the server is set to give a flashing blue beaconing indication. See [Interpreting LEDs](#), on page 36 for details.

The removable hard disks also have LEDs indicating hard disk access activity and hard disk health.

Buttons

The Reset button is just inside the chassis and must be pressed using the tip of a paper clip or a similar item. Hold the button down for five seconds and then release it to restart the server if other methods of restarting are not working.

The beaconing function for an individual server may get turned on or off by pressing the combination button and LED. See [Interpreting LEDs](#), on page 36 for details.

The power button and LED allows you to manually take a server temporarily out of service but leave it in a state where it can be restarted quickly.

Connectors

A console port gives a direct connection to a blade server to allow operating system installation and other management tasks to be done directly rather than remotely. The port uses the KVM dongle device included in the chassis accessory kit. See [KVM Cable](#), on page 83 for more information.

Cisco UCS B420 M4 Blade Server

For full service and installation instructions, see the [Cisco UCS B420 M4 Blade Server Installation and Service Note](#). You can install up to four UCS B420 M4 High Performance Blade Servers in a chassis.

Figure 9: Cisco UCS B420 M4 Blade Server Front Panel

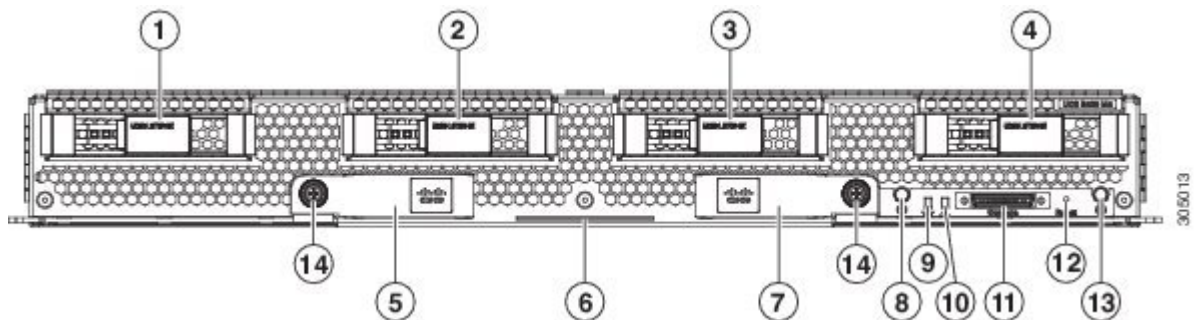

1	Hard drive bay 1	8	Power button and LED
2	Hard drive bay 2	9	Network link status button
3	Hard drive bay 3	10	Blade health LED
4	Hard drive bay 4	11	Local console connection
5	Left ejector handle	12	Reset button access
6	Serial pull tab	13	Locate button
7	Right ejector handle	14	Ejector thumb screw

LEDs

The LED indicators indicate whether the blade server is in active or standby mode, the status of the network link, the over all health of the blade server, and whether the server is set to give a flashing blue beaoning indication. See [Interpreting LEDs, on page 36](#) for details.

The removable hard disks also have LEDs indicating hard disk access activity and hard disk health.

Buttons

The Reset button is just inside the chassis and must be pressed using the tip of a paper clip or a similar item. Hold the button down for five seconds and then release it to restart the server if other methods of restarting are not working.

The beaoning function for an individual server may get turned on or off by pressing the combination button and LED. See [Interpreting LEDs, on page 36](#) for details.

The power button and LED allows you to manually take a server temporarily out of service but leave it in a state where it can be restarted quickly.

Connectors

A console port gives a direct connection to a blade server to allow operating system installation and other management tasks to be done directly rather than remotely. The port uses the KVM dongle device included in the chassis accessory kit. See [KVM Cable, on page 83](#) for more information.

Cisco UCS B260 M4 Scalable Blade Server

For full service and installation instructions, see the [Cisco UCS B260 M4 and B460 M4 Scalable Blade Server Installation and Service Note](#). You can install up to four UCS B260 M4 Blade Servers in the Cisco UCS 5108 server chassis.

Figure 10: Cisco UCS B260 M4 Scalable Blade Server

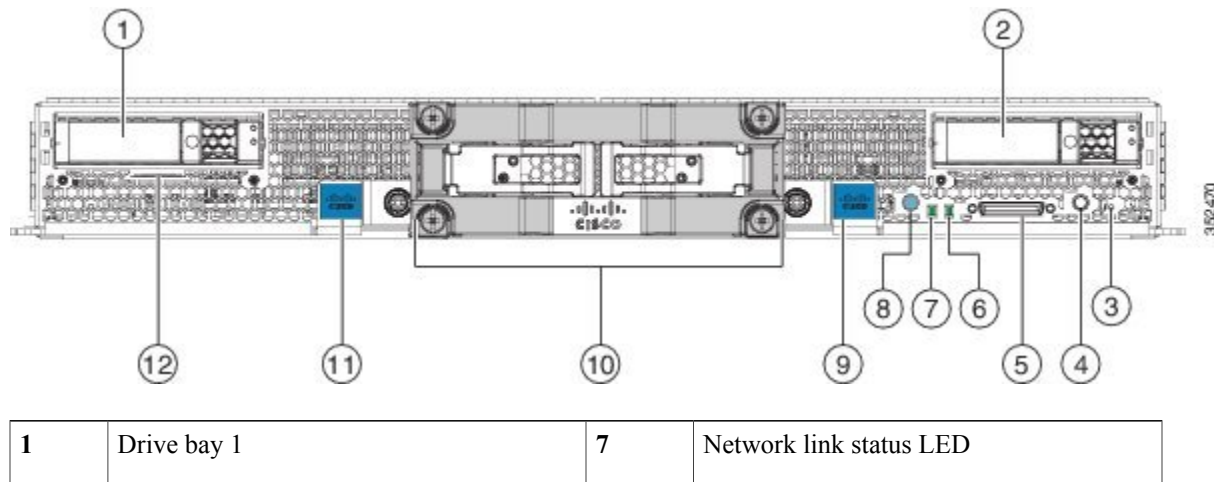

2	Drive bay 2	8	Power button and LED
3	Reset button access	9	Right ejector handle
4	Beaconing button and LED	10	UCS Scalability Terminator
5	Local console connection	11	Left ejector handle
6	Blade health LED	12	Asset tag Each server has a blank plastic tag that pulls out of the front panel so you can add your own asset tracking label without interfering with the intended air flow.

LEDs

The LED indicators indicate whether the blade server is in active or standby mode, the status of the network link, the over all health of the blade server, and whether the server is set to give a flashing blue beaconing indication. See [Interpreting LEDs, on page 36](#) for details.

The removable hard disks also have LEDs indicating hard disk access activity and hard disk health.

Buttons

The Reset button is just inside the chassis and must be pressed using the tip of a paper clip or a similar item. Hold the button down for five seconds and then release it to restart the server if other methods of restarting are not working.

The beaconing function for an individual server may get turned on or off by pressing the combination button and LED. See [Interpreting LEDs, on page 36](#) for details.

The power button and LED allows you to manually take a server temporarily out of service but leave it in a state where it can be restarted quickly.

Connectors

A console port gives a direct connection to a blade server to allow operating system installation and other management tasks to be done directly rather than remotely. The port uses the KVM dongle device included in the chassis accessory kit. See [KVM Cable, on page 83](#) for more information.

Cisco UCS B460 M4 Blade Server

For full service and installation instructions, see the [Cisco UCS B260 M4 and B460 M4 Scalable Blade Server Installation and Service Note](#). Up to two Cisco UCS B460 M4 Blade Servers can be installed in the Cisco UCS 5108 chassis.

Figure 11: Cisco UCS B460 M4 Blade Server

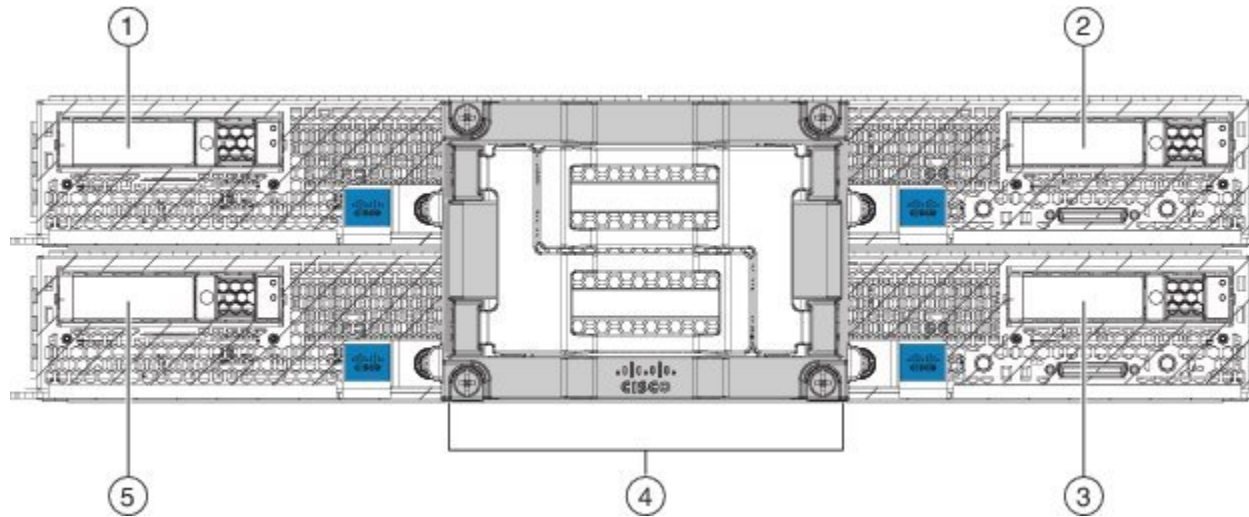

1	Drive bay 1	4	UCS Scalability Connector
2	Drive bay 2	5	Drive bay 4
3	Drive bay 3		

LEDs

The LED indicators indicate whether the blade server is in active or standby mode, the status of the network link, the over all health of the blade server, and whether the server is set to give a flashing blue beaconing indication. See [Interpreting LEDs, on page 36](#) for details.

The removable hard disks also have LEDs indicating hard disk access activity and hard disk health.

Buttons

The Reset button is just inside the chassis and must be pressed using the tip of a paper clip or a similar item. Hold the button down for five seconds and then release it to restart the server if other methods of restarting are not working.

The beaconing function for an individual server may get turned on or off by pressing the combination button and LED. See [Interpreting LEDs, on page 36](#) for details.

The power button and LED allows you to manually take a server temporarily out of service but leave it in a state where it can be restarted quickly.

Connectors

A console port gives a direct connection to a blade server to allow operating system installation and other management tasks to be done directly rather than remotely. The port uses the KVM dongle device included in the chassis accessory kit. See [KVM Cable](#), on page 83 for more information.

Adapter Cards

Depending on the model of server in question, one to three adapter cards will reside in each blade server, providing failover connectivity to each FEX in the chassis. The following models are available, and others are released on an ongoing basis:

Cisco UCS Virtual Interface Card 1240

The Cisco UCS Virtual Interface Card 1240 is a four-port 10 Gigabit Ethernet, Fibre Channel over Ethernet (FCoE)-capable modular LAN on motherboard (mLOM) designed exclusively for the M3 generation of Cisco UCS B-Series blade servers. When used in combination with an optional port expander, the Cisco UCS VIC 1240 capabilities can be expanded to either ports of 10 Gigabit Ethernet.

The Cisco UCS VIC 1240 enables a policy-based, stateless, agile server infrastructure that can present up to 256 PCIe standards-compliant interfaces to the host that can be dynamically configured as either network interface cards (NICs) or host bus adapters (HBAs). In addition, the Cisco UCS VIC 1240 supports Cisco Data Center Virtual Machine Fabric Extender (VM-FEX) technology, which extends the Cisco UCS fabric interconnect ports to virtual machines, simplifying server virtualization deployment.

Cisco UCS Virtual Interface Card 1280

The Cisco UCS Virtual Interface Card 1280 (UCS-VIC-M82-8P) is an eight-port 10 Gigabit Ethernet, Fibre Channel over Ethernet (FCoE)-capable mezzanine card designed exclusively for Cisco UCS B-Series Blade Servers. The card enables a policy-based, stateless, agile server infrastructure that can present up to 256 PCIe standards-compliant interfaces to the host that can be dynamically configured as either network interface cards (NICs) or host bus adapters (HBAs). In addition, the Cisco UCS Virtual Interface Card 1280 supports Cisco Virtual Machine Fabric Extender (VM-FEX) technology, which extends the Cisco UCS Fabric Interconnect ports to virtual machines, simplifying server virtualization deployment.

Cisco UCS M81KR Virtual Interface Card

The Cisco UCS M81KR Virtual Interface Card is a virtualization-optimized Fibre Channel over Ethernet (FCoE) adapter card. The virtual interface card is a dual-port 10 Gigabit Ethernet adapter card that supports up to 128 Peripheral Component Interconnect Express (PCIe) standards-compliant virtual interfaces that can be dynamically configured so that both their interface type (network interface card [NIC] or host bus adapter [HBA]) and identity (MAC address and worldwide name [WWNN]) are established using just-in-time provisioning. In addition, the Cisco UCS M81KR supports network interface virtualization and Cisco VN-Link technology.

The Cisco UCS M81KR is designed for both traditional operating system and virtualization environments. It is optimized for virtualized environments, for organizations that seek increased mobility in their physical environments, and for data centers that want reduced TCO through NIC, HBA, cabling, and switch reduction.

The Cisco UCS M81KR presents up to 128 virtual interfaces to the operating system on a given blade. The 128 virtual interfaces can be dynamically configured by Cisco UCS Manager as either Fibre Channel or Ethernet devices. Deployment of applications using multiple Ethernet and Fibre Channel interfaces is no longer constrained by the available physical adapters. To an operating system or a hypervisor running on a Cisco UCS B-Series Blade Server, the virtual interfaces appear as regular PCIe devices.

The Cisco UCS M81KR has built-in architectural support enabling the virtual machine to directly access the adapter. I/O bottlenecks and memory performance can be improved by providing virtual machines direct access to hardware I/O devices, eliminating the overhead of embedded software switches.

The Cisco UCS M81KR also brings adapter consolidation to physical environments. The adapter can be defined as multiple different NICs and HBAs. For example, one adapter card can replace two quad-port NICs and two single-port HBAs, resulting in fewer NICs, HBAs, switches, and cables.

Cisco UCS 82598KR-CI 10 Gigabit Ethernet Adapter

The Cisco UCS 82598KR-CI 10 Gigabit Ethernet adapter is based on the Intel 82598 10 Gigabit Ethernet controller, which is designed for efficient high-performance Ethernet transport. It provides a solution for data center environments that need low-latency 10 Gigabit Ethernet transport capability, and a dual-port connection to the midplane of the blade server chassis.

The Cisco UCS 82598KR-CI supports Intel Input/Output Acceleration Technology (I/OAT) as well as virtual queues for I/O virtualization. The adapter is energy efficient and can also help reduce CPU utilization by providing large segment offload (LSO) and TCP segmentation offload (TSO). The Cisco UCS 82598KR-CI uses Intel Virtual Machine Device Queue (VMDq) technology for the efficient routing of packets to the appropriate virtual machine.

Cisco UCS M71KR-E Emulex Converged Network Adapter

The Cisco UCS M71KR-E Emulex Converged Network Adapter (CNA) is an Emulex-based Fibre Channel over Ethernet (FCoE) adapter card that provides connectivity for Cisco UCS B-Series Blade Servers in the Cisco Unified Computing System.

Designed specifically for the Cisco UCS blades, the adapter provides a dual-port connection to the midplane of the blade server chassis. The Cisco UCS M71KR-E uses an Intel 82598 10 Gigabit Ethernet controller for network traffic and an Emulex 4-Gbps Fibre Channel controller for Fibre Channel traffic all on the same adapter card. The Cisco UCS M71KR-E presents two discrete Fibre Channel host bus adapter (HBA) ports and two Ethernet network ports to the operating system.

The Cisco UCS M71KR-E provides both 10 Gigabit Ethernet and 4-Gbps Fibre Channel functions using drivers from Emulex, providing:

- Compatibility with current Emulex adapter-based SAN environments and drivers
- Consolidation of LAN and SAN traffic over the same adapter card and fabric, reducing the overall number of network interface cards (NICs), HBAs, cables, and switches
- Integrated management with Cisco UCS Manager

Cisco UCS M71KR-Q QLogic Converged Network Adapter

The Cisco UCS M71KR-Q QLogic Converged Network Adapter (CNA) is a QLogic-based Fibre Channel over Ethernet (FCoE) adapter card that provides connectivity for Cisco UCS B-Series Blade Servers in the Cisco Unified Computing System.

Designed specifically for the Cisco UCS blades, the adapter provides a dual-port connection to the midplane of the blade server chassis. The Cisco UCS M71KR-Q uses an Intel 82598 10 Gigabit Ethernet controller for network traffic and a QLogic 4-Gbps Fibre Channel controller for Fibre Channel traffic, all on the same adapter card. The Cisco UCS M71KR-Q presents two discrete Fibre Channel host bus adapter (HBA) ports and two Ethernet network ports to the operating system.

The Cisco UCS M71KR-Q provides both 10 Gigabit Ethernet and 4-Gbps Fibre Channel functions using drivers from QLogic, providing:

- Compatibility with current QLogic adapter-based SAN environments and drivers
- Consolidation of LAN and SAN traffic over the same adapter card and fabric, reducing the overall number of network interface cards (NICs), HBAs, cables, and switches
- Integrated management with Cisco UCS Manager

Cisco UCS 6324 Fabric Interconnect

The Cisco UCS 6324 Fabric Interconnect (UCS-FI-M-6324) is an integrated fabric interconnect and I/O module. It can be configured only with the UCSB-5108-AC2 and UCSB-5108-DC2 versions of the chassis.

Figure 12: Cisco UCS 6324 Fabric Interconnect

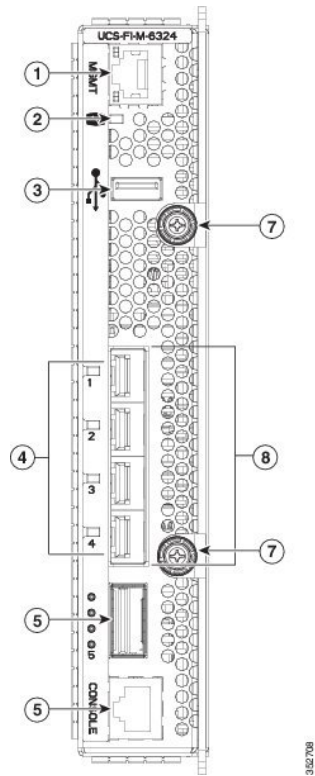

1	Management port	5	QSFP+ licensed server port
2	Power-on LED	6	Console management port
3	USB port	7	Ejector captive screws
4	Port LEDs	8	Four SPF+ unified ports

The Cisco UCS 6324 Fabric Interconnect connects directly to external Cisco Nexus switches through 10-Gigabit Ethernet ports and Fibre Channel over Ethernet (FCoE) ports.

The Cisco UCS 6324 Fabric Interconnect fits into the back of the Cisco UCS Mini chassis. Each Cisco UCS Mini chassis can support up to two UCS 6324 Fabric Interconnects, which enables increased capacity as well as redundancy.

Cisco UCS 2304 IOM

The Cisco UCS 2304 IOM (Fabric Extender) is an I/O module with 8 40-Gigabit backplane ports and 4 40-Gigabit uplink ports. It can be hot-plugged into the rear of a Cisco UCS 5100 Series blade server chassis. A maximum of two UCS 2304 IOMs can be installed in a chassis.

The Cisco UCS 2304 IOM joins the third generation of UCS products, including the following hardware:

- Cisco UCS 6332 fabric interconnect, an Ethernet or Fibre Channel over Ethernet (FCoE) chassis with 32 QSFP+ 40-Gigabit ports
- Cisco UCS 6332-16UP fabric interconnect, a Ethernet and Fibre Channel chassis with 16 1- or 10-Gigabit SFP+ ports or 16 4-, 8-, or 16-Gigabit Fibre Channel ports, and 24 40-Gigabit QSFP+ ports
- Cisco UCS 2304 IOM
- Multiple VICs

The Cisco UCS 2304 IOM provides chassis management control and blade management control, including control of the chassis, fan trays, power supply units, and blades. It also multiplexes and forwards all traffic

from the blade servers in the chassis to the 10-Gigabit Ethernet uplink network ports that connect to the fabric Interconnect. The IOM can also connect to a peer IOM to form a cluster interconnect.

Figure 13: Cisco UCS 2304 IOM

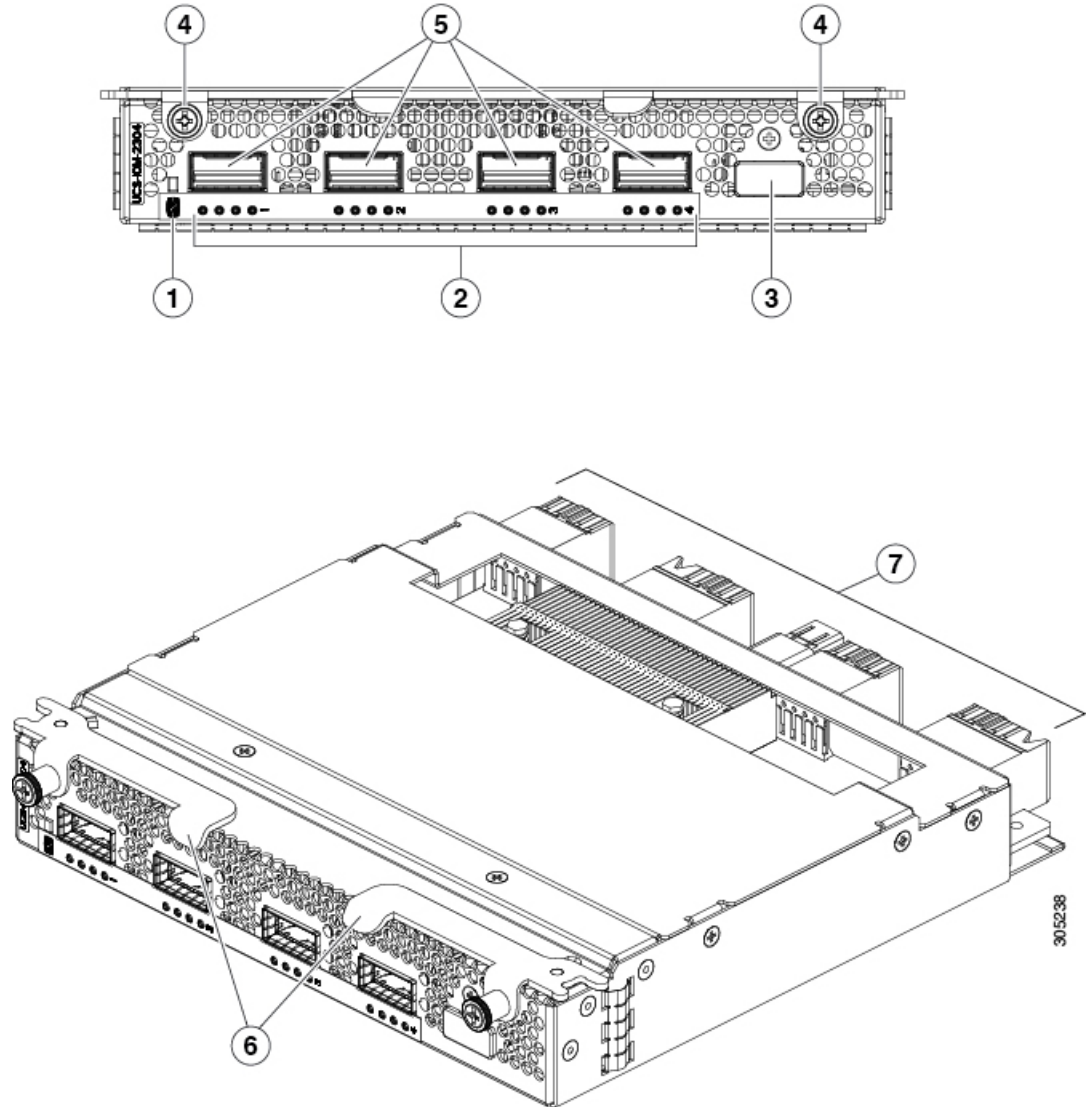

1	System status LED	2	QSFP port activity LEDs
3	HDMI console connector and Ethernet management port	4	Captive screws for the insertion latches
5	40-Gigabit uplink ports	6	Insertions latches
7	40-Gigabit backplane ports		

LEDs

The front of the IOM has a system status LED and port activity LEDs.

Buttons

There are no buttons on the IOM.

Connectors

There are four QSFP, 40-Gigabit uplink ports on the front of the IOM. The Ethernet management port and console connector use an HDMI connector that connects to a special Y dongle to expose the 10/100 RJ45 port and console connections.

Cisco UCS 2200 Series FEXes

Figure 14: Cisco UCS 2208 FEX (UCS-IOM-2208XP)

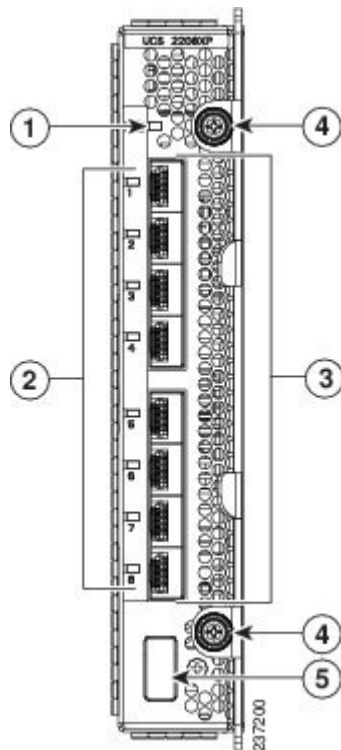

1	Fabric extender status indicator LED	4	Captive screws for the insertion latches
2	Link status indicator LEDs	5	HDMI console connector for use by Cisco service technicians

3	Connection ports (to the fabric interconnect)		
---	---	--	--

Figure 15: Cisco UCS 2204XP FEX

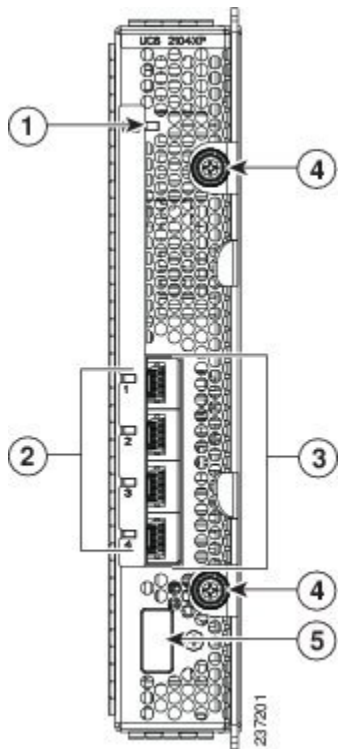

1	Fabric extender status indicator LED	4	Captive screws for the insertion latches
2	Link status indicator LEDs	5	HDMI console connector for use by Cisco service technicians
3	Connection ports (to the fabric interconnect)		

Cisco UCS 2200 Series FEXes bring the unified fabric into the blade server enclosure, providing 10 Gigabit Ethernet connections between blade servers and the fabric interconnect, simplifying diagnostics, cabling, and management.

The Cisco UCS 2200 Series extends the I/O fabric between the fabric interconnects and the Cisco UCS 5100 Series Blade Server Chassis, enabling a lossless and deterministic Fibre Channel over Ethernet (FCoE) fabric to connect all blades and chassis together. Because the FEX is similar to a distributed line card, it does not do any switching and is managed as an extension of the fabric interconnects. This approach removes switching from the chassis, reducing overall infrastructure complexity and enabling the Cisco Unified Computing System to scale to many chassis without multiplying the number of switches needed, reducing TCO and allowing all chassis to be managed as a single, highly available management domain.

The Cisco 2200 Series also manages the chassis environment (the power supply and fans as well as the blades) in conjunction with the fabric interconnect. Therefore, separate chassis management modules are not required.

Cisco UCS 2200 Series FEXes fit into the back of the Cisco UCS 5100 Series chassis. Each Cisco UCS 5100 Series chassis can support up to two FEXes, enabling increased capacity as well as redundancy.

LEDs

There are port activity LEDs and an LED that indicates connectivity to the servers in the chassis.

Buttons

No buttons are on the FEX.

Connectors

I/O ports support SFP+ 10 Gb Ethernet connections. There is also an HDMI console connector on the front of the FEX that is intended for use by Cisco service technicians. This connector is not intended for customer use. Because of the ability to access the FEX controller itself, physical access to this connector should be controlled at all times by using the HDMI press-fit plug that ships with the FEX or by taking other appropriate physical protections.

Cisco UCS 2104XP FEXes

Figure 16: Cisco UCS 2104 IO Module

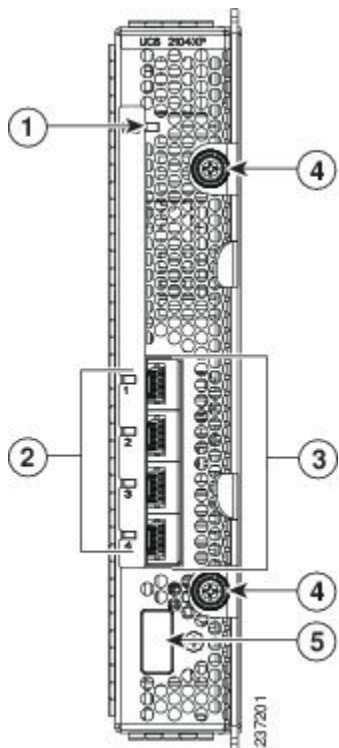

1	Fabric extender status indicator LED	4	Captive screws for the insertion latches
2	Link status indicator LEDs	5	HDMI console connector for use by Cisco service technicians
3	Connection ports (to the fabric interconnect)		

Cisco UCS 2100 Series FEXes bring the unified fabric into the blade server enclosure, providing 10 Gigabit Ethernet connections between blade servers and the fabric interconnect, simplifying diagnostics, cabling, and management.

The Cisco UCS 2104 (N20-I6584) extends the I/O fabric between the fabric interconnects and the Cisco UCS 5100 Series Blade Server Chassis, enabling a lossless and deterministic Fibre Channel over Ethernet (FCoE) fabric to connect all blades and chassis together. Because the FEX is similar to a distributed line card, it does not do any switching and is managed as an extension of the fabric interconnects. This approach removes switching from the chassis, reducing overall infrastructure complexity and enabling the Cisco Unified Computing System to scale to many chassis without multiplying the number of switches needed, reducing TCO and allowing all chassis to be managed as a single, highly available management domain.

The Cisco 2100 Series also manages the chassis environment (the power supply and fans as well as the blades) in conjunction with the fabric interconnect. Therefore, separate chassis management modules are not required.

Cisco UCS 2100 Series FEXes fit into the back of the Cisco UCS 5100 Series chassis. Each Cisco UCS 5100 Series chassis can support up to two FEXes, enabling increased capacity as well as redundancy.

LEDs

There are port activity LEDs and an LED that indicates connectivity to the servers in the chassis.

Buttons

No buttons are on the FEX.

Connectors

I/O ports support SFP+ 10 Gb Ethernet connections. There is also an HDMI console connector on the front of the FEX that is intended for use by Cisco service technicians. This connector is not intended for customer use. Because of the ability to access the FEX controller itself, physical access to this connector should be controlled at all times by using the HDMI press-fit plug that ships with the FEX or by taking other appropriate physical protections.

Power Distribution Unit (PDU)

The AC PDU (N01-UAC1) provides load balancing between the installed power supplies, as well as distributing power to the other chassis components. DC versions of the chassis use a different PDU with appropriate connectors. The PDU is not field-serviceable, and converting an AC chassis to a DC chassis by swapping the PDU is not supported, as the PDU is not separately orderable.

LEDs

No LEDs are on the PDU.

Buttons

No buttons are on the PDU.

Connectors

The AC version of the PDU has four power connectors rated for 15.5 A, 200-240V @ 50-60 Hz. Only use power cords that are certified by the relevant country safety authority or that are installed by a licensed or certified electrician in accordance with the relevant electrical codes. All connectors, plugs, receptacles, and cables must be rated to at least the amperage of inlet connector on the PSU or be independently fused in accordance with the relevant electrical code. See for more information about the supported power cords. See [Supported AC Power Cords and Plugs](#), on page 89 for more information.

The DC version of the PDU has eight dual-post lug power connections, four positive and four negative. A single dual-post lug grounding connection is also provided. The HDVC version of the PDU uses one Andersen SAF-D-GRID(R) connector per power supply.

Fan Modules

The chassis can accept up to eight fan modules (N20-FAN5). A chassis must have filler plates in place if no fan will be installed in a slot for an extended period.

LEDs

There is one LED indication of the fan module's operational state. See [Interpreting LEDs, on page 36](#) for details.

Buttons and Connectors

No buttons or connectors are on a fan module.

Power Supplies

Different power supplies are available to work with the AC (UCSB-PSU-2500ACPL or N20-PAC5-2500W) or DC (UCSB-PSU-2500DC48) versions of the chassis.

When configured with the Cisco UCS 6324 Fabric Interconnect, only the following power supplies are supported: UCSB-PSU-2500ACDV dual-voltage supply and UCSB-PSU-2500DC48 -48V DC power supply.

To determine the number of power supplies needed for a given configuration, use the [Cisco UCS Power Calculator](#) tool.

LEDs

Two LEDs indicate power connection presence, power supply operation, and fault states. See [Interpreting LEDs, on page 36](#) for details.

Buttons

There are no buttons on a power supply.

Connectors

The power connections are at the rear of the chassis on the PDU, with different types for AC, DC, or HVDC input. Four hot-swappable power supplies are accessible from the front of the chassis. These power supplies can be configured to support non-redundant, N+1 redundant, and grid-redundant configurations.

Power Supply Redundancy

Power supply redundancy functions identically for AC and DC configured systems. When considering power supply redundancy you need to take several things into consideration:

- AC power supplies are all single phase and have a single input for connectivity to customer power source (a rack PDU such as the Cisco RP Series PDU or equivalent).
- The number of power supplies required to power a chassis varies depending on the following factors:
 - The total "Maximum Draw" required to power all the components configured within that chassis—such as I/O modules, fans, blade servers (CPU and memory configuration of the blade servers).
 - The Desired Power Redundancy for the chassis. The supported power configurations are non-redundant, N+1 redundancy (or any requirement greater than N+1), and grid redundancy.

To configure redundancy, see the *Configuration Guide* for the version of Cisco UCS Manager that you are using. The configuration guides are available at the following URL: http://www.cisco.com/en/US/products/ps10281/products_installation_and_configuration_guides_list.html.

Non-redundant Mode

In non-redundant mode, the system may go down with the loss of any supply or power grid associated with any particular chassis. We do not recommend running a production system in non-redundant mode. To operate in non-redundant mode, each chassis should have at least two power supplies installed. Supplies that are not used by the system are placed into standby. The supplies that are placed into standby depends on the installation order (not on the slot number). The load is balanced across active power supplies, not including any supplies in standby.

When using Cisco UCS Release 1.3(1) or earlier releases, small configurations that use less than 25000W may be powered up on a single power supply. When using Cisco UCS Release 1.4(1) and later releases, the chassis requires a minimum of 2 power supplies.

**Note**

In a non-redundant system, power supplies can be in any slot. Installing less than the required number of power supplies results in undesired behavior such as server blade shutdown. Installing more than the required amount of power supplies may result in lower power supply efficiency. At most, this mode will require two power supplies.

N+1 Redundancy

The N+1 redundancy configuration implies that the chassis contains a total number of power supplies to satisfy non-redundancy, plus one additional power supply for redundancy. All the power supplies that are participating in N+1 redundancy are turned on and equally share the power load for the chassis. If any additional power supplies are installed, Cisco UCS Manager recognizes these "unnecessary" power supplies and places them on standby.

If a power supply should fail, the surviving supplies can provide power to the chassis. In addition, UCS Manager turns on any "turned-off" power supplies to bring the system back to N+1 status.

To provide N+1 protection, the following number of power supplies is recommended:

- Three power supplies are recommended if the power configuration for that chassis requires greater than 2500 W or if using UCS Release 1.4(1) and later releases
- Two power supplies are sufficient if the power configuration for that chassis requires less than 2500 W or the system is using UCS Release 1.3(1) or earlier releases
- Four power supplies are recommended when running the dual-voltage power supply from a 100 - 120V source.

Adding an additional power supply to either of these configurations will provide an extra level of protection. Cisco UCS Manager turns on the extra power supply in the event of a failure and restores N+1 protection.



Note

An n+1 redundant system has either two or three power supplies, which may be in any slot.

Grid Redundancy

The grid redundant configuration is sometimes used when you have two power sources to power a chassis or you require greater than N+1 redundancy. If one source fails (which causes a loss of power to one or two power supplies), the surviving power supplies on the other power circuit continue to provide power to the chassis. A common reason for using grid redundancy is if the rack power distribution is such that power is provided by two PDUs and you want the grid redundancy protection in the case of a PDU failure.

To provide grid redundant (or greater than N+1) protection, the following number of power supplies is recommended:

- Four power supplies are recommended if the power configuration for that chassis requires greater than 2500W or if using Cisco UCS Release 1.4(1) and later releases
- Two power supplies are recommended if the power configuration for that chassis requires less than 2500W or the system is using Cisco UCS Release 1.3(1) or earlier releases



Note

Both grids in a power redundant system should have the same number of power supplies. If your system is configured for grid redundancy, slots 1 and 2 are assigned to grid 1 and slots 3 and 4 are assigned to grid 2. If there are only two power supplies (PS) in the a redundant mode chassis, they should be in slots 1 and 3. Slot and cord connection numbering is shown below.

Figure 17: Power Supply Bay and Connector Numbering

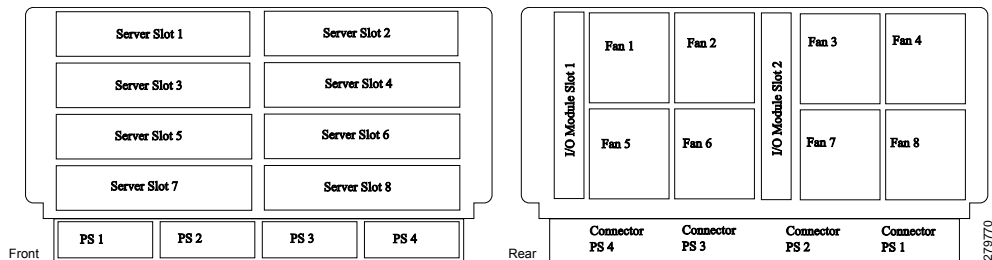

LEDs

LEDs on both the chassis and the modules installed within the chassis identify operational states, both separately and in combination with other LEDs.

LED Locations

Figure 18: LEDs on a Cisco UCS 5108 Server Chassis—Front View

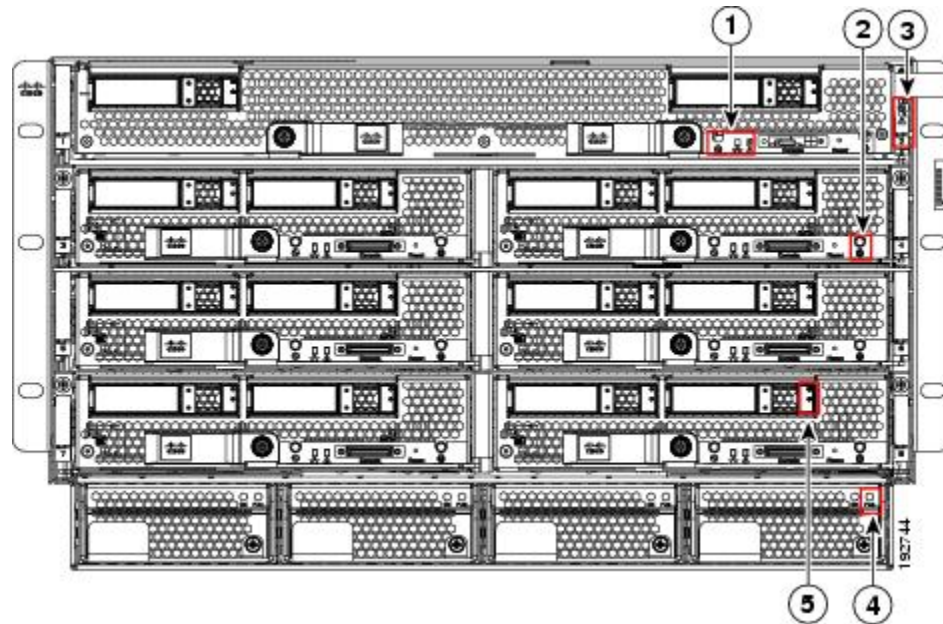

Figure 19: LEDs on the Cisco UCS 5108 Server Chassis—Rear View

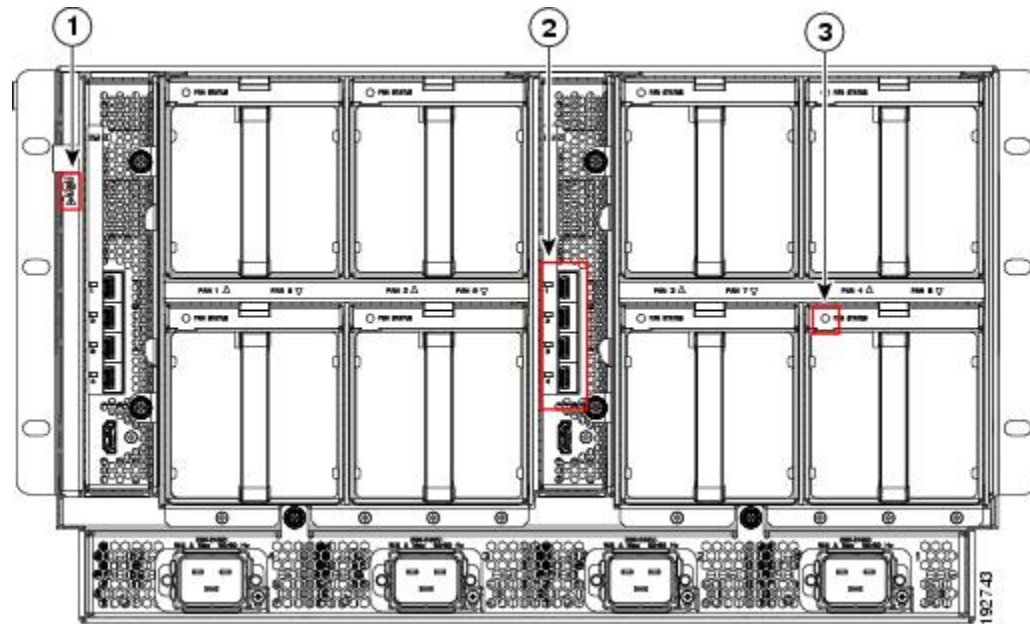
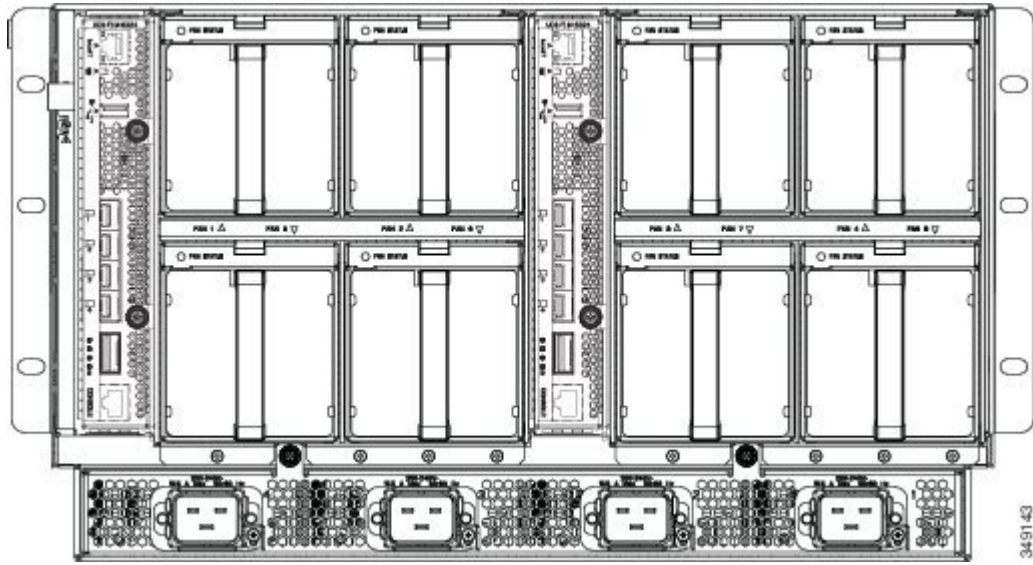





Figure 20: Cisco UCS 5108 Server Chassis—Rear View with the Cisco UCS 6324 Fabric Interconnect



Interpreting LEDs

Table 2: Chassis, Fan, and Power Supply LEDs

LED	Color	Description
 Beaconing LED and button	Off	Beaconing not enabled.
	Blinking blue 1 Hz	Beaconing to locate a selected chassis—If the LED is not blinking, the chassis is not selected. You can initiate beaconing in UCS Manager or with the button.
 Chassis connections	Off	No power.
	Amber	No I/O module is installed or the I/O module is booting.
	Green	Normal operation.
 Chassis health	Solid amber	Indicates a component failure or a major over-temperature alarm.

LED	Color	Description
Fan Module	Off	No power to the chassis or the fan module was removed from the chassis.
	Amber	Fan module restarting.
	Green	Normal operation.
	Blinking amber	The fan module has failed.
Power Supply		
OK	Off	No power to the slot.
	Green	Normal operation.
	Blinking green	AC power is present but the PS is either in redundancy standby mode or is not fully seated.
Fail	Off	Normal operation.
	Amber	Over-voltage failure or over-temperature alarm.

Table 3: I/O Module LEDs

LED	Color	Description
Body ⊗	Off	No power.
	Green	Normal operation.
	Amber	Booting or minor temperature alarm.
	Blinking amber	POST error or other error condition.
Port 1-4	Off	Link down.
	Green	Link up and operationally enabled.
	Amber	Link up and administratively disabled.
	Blinking amber	POST error or other error condition.

Table 4: UCS 2304 I/O Module LEDs

LED	Color	Description
System 	Off	Power off.
	Green	Normal operation.
	Amber	Booting or minor temperature alarm.
	Blinking amber	Stopped in U-Boot due to user intervention or unable to come online or major temperature alarm.
Port 1-4	Off	Link enabled but no connected.
	Green	Link connected.
	Amber	Operator disabled.
	Blinking amber	Disabled due to error.

Table 5: Cisco UCS 6324 Fabric Interconnect LEDs







LED	Color	Description
Body 	Off	No power.
	Green	Normal operation.
	Amber	Booting or minor temperature alarm.
	Blinking amber	Stopped due to user intervention or unable to come online, or major temperature alarm.
Port 1-4	Off	Link enabled but not connected.
	Green	Link connected.
	Amber	Operator disabled.
	Blinking amber	Disabled due to error.

Table 6: Blade Server LEDs

LED	Color	Description
Power 	Off	Power off.
	Green	Normal operation.
	Amber	Standby.
Link 	Off	None of the network links are up.
	Green	At least one network link is up.
Health 	Off	Power off.
	Green	Normal operation.
	Amber	Minor error.
	Blinking Amber	Critical error.
Activity  (Disk Drive)	Off	Inactive.
	Green	Outstanding I/O to disk drive.
Health  (Disk Drive)	Off	No fault.
	Amber	Some fault.



Installation

This chapter contains the following sections:

- [Installation Notes and Warnings for the Cisco UCS 5108 Server Chassis](#), page 41
- [Installing the Chassis](#), page 46
- [Repacking the Chassis](#), page 60
- [SFP+ Transceivers](#), page 60

Installation Notes and Warnings for the Cisco UCS 5108 Server Chassis

The following notes and warnings apply to all installation tasks:



Note

Before you install, operate, or service the system, see the [Regulatory Compliance and Safety Information for Cisco UCS](#) for important safety information.



Warning

IMPORTANT SAFETY INSTRUCTIONS

This warning symbol means danger. You are in a situation that could cause bodily injury. Before you work on any equipment, be aware of the hazards involved with electrical circuitry and be familiar with standard practices for preventing accidents. Use the statement number provided at the end of each warning to locate its translation in the translated safety warnings that accompanied this device. Statement 1071

SAVE THESE INSTRUCTIONS



Warning

This unit is intended for installation in restricted access areas. A restricted access area can be accessed only through the use of a special tool, lock and key, or other means of security. Statement 1017

**Warning**

Only trained and qualified personnel must be allowed to install, replace, or service this equipment. Statement 1030

Rack Requirements

This section provides the requirements for installing in a standard open rack, assuming an external ambient air temperature range of 50 to 95°F (10 to 35°C):

**Note**

Do not use racks that have obstructions. These obstructions could impair access to field-replaceable units (FRUs).

The Cisco R Series Racks are an ideal choice. If other racks will be used, the rack must be of the following type:

- Standard 19-inch (48.3 cm) four-post EIA rack, a minimum of 39.4 inches (100 cm) deep, with mounting rails that conform to English universal hole spacing per section 1 of ANSI/EIA-310-D-1992.
- The mounting holes of the rails in the rack must be square (unless the optional round hole adapter kit is used).
- The tool-less rack-mount kit shipped with the chassis is required. The adjustable rack rails shipped with each enclosure extend from 29 inches (73.66 cm) to 35 inches (88.9 cm)
- Front and rear doors—If your server rack includes closing front and rear doors, the doors must have 65 percent open perforated area evenly distributed from top to bottom to permit adequate airflow.

**Caution**

Always use blanking panels to fill all remaining empty front panel U-spaces in the rack. This arrangement ensures proper airflow. Using a rack without blanking panels results in improper cooling that can lead to thermal damage.

The rack must also meet the following requirements:

- The minimum available vertical rack space per chassis must be six RU (rack units), equal to 10.5 inches (26.7 cm).

Cable Management

To help with cable management, allow additional space in the rack above and below the chassis to make it easier to route copper cables (plus up to eight copper cables per Cisco UCS 5108 server chassis) through the rack.

Cable management can be an important factor in preventing overheating issues. In the following figure, the “before” illustration shows cables blocking the rear of the chassis, and preventing the fans from exhausting warm air from the chassis. This situation causes failed DIMMs in the blade servers, and seemingly random

server shutdowns when internal temperatures exceed specification. Use cable ties and other wiring practices to keep the rear of the chassis unobstructed as shown in the “after” illustration.

Figure 21: Cable Management

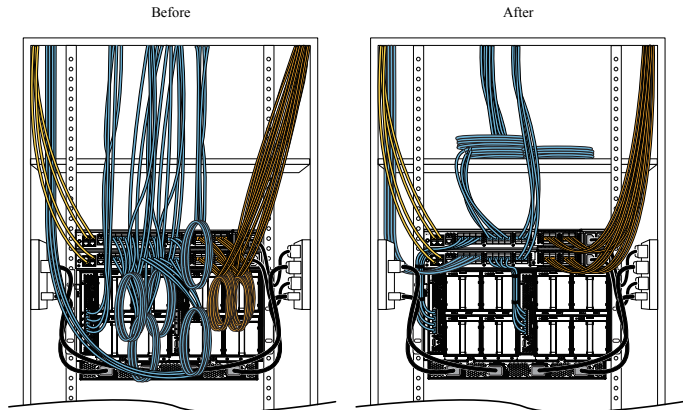

Airflow Considerations

Airflow through the chassis is from front to back. Air enters the chassis through the blade servers and power supply grills at the front of the chassis and exits through the fan modules on the back of the chassis. To ensure proper airflow, follow these guidelines:

- Maintain ambient airflow throughout the data center to ensure normal operation.
- Consider the heat dissipation of all equipment when determining air-conditioning requirements. Do not allow the exhaust of one system to be the intake for another system.
- When evaluating airflow requirements, take into consideration that the hot air generated by equipment at the bottom of the rack can be drawn in the intake of the equipment above.
- Make sure that the exhaust at the rear of the chassis is unobstructed for at least 24 in. (61 cm). This includes obstruction due to messy cabling practices.
- Some blade servers ship with internal air baffles that are placed over the DIMMs and CPUs. They are used to channel airflow to where it is needed the most. The blades are designed to operate with air baffles installed and the system will not cool correctly if they are not installed.
- If an enclosed rack is used, the front door must be 65 percent perforated to ensure adequate airflow to the servers.

Moving Server Chassis

When lifting the chassis, be aware of its weight, and follow these guidelines:



Caution

Do not try to lift the chassis using the handles on the side. These handles are intended only for moving and adjusting the chassis position.

- Never lift the chassis alone—Always use two people to lift the chassis. If available, use a scissor jack or other lifting device designed for installing heavy equipment into data center racks.
- Disconnect all power and external cables before lifting the chassis.
- Remove all FEXes, power supplies, fans, and servers from the chassis before lifting.
- Ensure that your footing is solid and the weight of the system is evenly distributed between your feet.
- Lift the system slowly, keeping your back straight. Lift with your legs, not with your back. Bend at the knees, not at the waist.

**Caution**

Do not remove the Power Distribution Unit (PDU) located at the back of the chassis.

Installation Guidelines

When installing the chassis, follow these guidelines:

- Plan your site configuration and prepare the site before installing the chassis. See [Site Planning and Maintenance Records, on page 95](#) for the recommended site planning tasks. For details, see the [Cisco UCS Site Preparation Guide](#).
- Record the information listed in [Site Planning and Maintenance Records, on page 95](#) as you install and configure the chassis.
- Ensure that there is adequate space around the chassis to allow for servicing the chassis and for airflow.
- Ensure that the air-conditioning meets the heat dissipation requirements listed in [Technical Specifications, on page 83](#)
- Ensure that the cabinet or rack meets the requirements listed in [Rack Requirements, on page 42](#).

**Note**

Jumper power cords are available for use in a rack. See [Specifications for the Cisco UCS 5108 Blade Server Chassis Power Supply Units, on page 86](#).

- Ensure that the site power meets the power requirements listed in [Technical Specifications, on page 83](#). We recommend that you use a UPS to protect the UCS system. Using an unprotected supply exposes you to a risk of system failure due to input supply voltage variations or failures.

Avoid UPS types that use ferroresonant technology. These UPS types can become unstable with systems such as the Cisco UCS, which can have substantial current draw fluctuations due to fluctuating data traffic patterns.

- Ensure that circuits are sized according to local and national codes. For North America, the power supply requires a 20 A circuit.

To prevent loss of input power, ensure that the total maximum loads on the circuits supplying power to the chassis are within the current ratings for the wiring and breakers.

- Use the following torque values when installing the chassis:

- 10-32 screws: 20 in-lb

Required Equipment

Before you begin the installation, ensure that you have the following items:

- Number 1 and number 2 Phillips-head screwdrivers with torque measuring capabilities
- Tape measure and level
- ESD wrist strap or other grounding device
- Antistatic mat or antistatic foam

Unpacking and Inspecting the Chassis

**Caution**

When handling chassis components, wear an ESD strap and handle modules by the carrier edges only.

**Tip**

Keep the shipping container in case the chassis requires shipping in the future.

**Note**

The chassis is thoroughly inspected before shipment. If any damage occurred during transportation or any items are missing, contact your customer service representative immediately.

Procedure

- Step 1** Remove the chassis from its cardboard container. Save all packaging material.
- Step 2** Compare the shipment to the equipment list provided by your customer service representative and verify that you have received the following items:
- Any printed documentation
 - Tool-less rack-mount kit (N20-CRMK2=)—mounting rails can be installed in a rack without the use of tools. The optional round hole adapter kit (N20-CRMK2-RHA=) does require tools.
 - ESD wrist strap
 - Cables with connectors (including the N20-BKVM=, which is the KVM/local I/O console dongle)
 - Any optional items ordered
- Step 3** Verify that all unused blade slots and power supply bays have blank covers.

Attaching the Round Hole Adapter Kit to the Rails (Optional)



Note The chassis tool-less rails are designed for racks that have square mounting holes. You must use the round hole adapters (N20-CRMK2-RHA=) to install the chassis in racks that have round mounting holes.

This round hole adapter kit allows you to adapt the rail kit (N20-CRMK2=) to install into rack (front and/or rear) posts that use either threaded or non-threaded round holes. Four adapters in the kit are for adapting the rail kit to install into rack posts with threaded round holes, and the other four adapters in the kit are for adapting the rail kit to install into rack posts with non-threaded round holes. You can use a combination of adapters based on the type of holes in the rack posts. Various sizes and lengths of screws are also included in the kit.

Procedure

- Step 1** Insert the adapter tab into the mounting rail as shown in callout 1.
- Step 2** Slide the adapter up to lock it into position as shown in callout 2.
- Step 3** Secure the adapter into place using the provided pan-head screw as shown in callout 3.

Figure 22: Attaching the Round Hole Adapter (Optional)

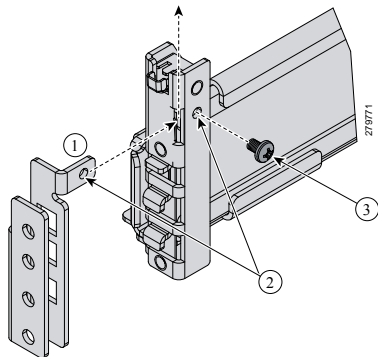

- Step 4** Repeat steps 1 to 3 for the other three adapters.

Installing the Chassis

This section describes how to install the chassis. This two part process consists of installing the rails into the rack and then installing the chassis into the rack and on to the rails.



Caution Never attempt to lift the chassis by using an installed module's handle as a grip point. Only use the handles on the sides of the chassis.

**Caution**

If the rack has wheels, ensure that the brakes are engaged, the stabilizing pads are extended, or that the rack is otherwise stabilized.

Table 7: Contents of the Cisco UCS 5108 Server Chassis Rack-Mount Kit (N20-CRMK2=)

Quantity	Part Description
1	Left tool-less rack mount rail
1	Right tool-less rack mount rail
6	10-32 X 0.75 Phillips round washer head screws
6	10-32 X 0.125 cage nuts

Table 8: Contents of the Cisco UCS 5108 Server Round Hole Adapter Kit (N20-CRMK2-RHA=)

Quantity	Part Description
4	Round hole adapters (threaded)
4	Round hole adapters (un-threaded)
4	Adapter securing screws
16	Phillips head screws for securing the rails to the rack

**Warning**

The plug-socket combination must be accessible at all times, because it serves as the main disconnecting device. Statement 1019

Installing the Rails

Procedure

- Step 1** Remove the mounting template (Cisco 78-19093-01) from the accessory box. The template is designed to show you the proper holes within which the rails and cage nuts should be placed. Once the rack holes line up with the template, you should mark the holes so that their position is known after removing the template.
- Step 2** Adjust the length of the rail by sliding the ends of the rail back and forth until they match the depth of the rack.

Figure 23: Adjusting the Tool-less Rack Mount Rail

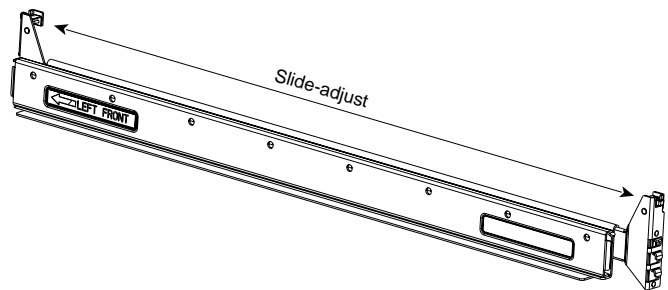

- Step 3** Place the two hooks at each end of the rail into the first two holes at a rack unit boundary.

Figure 24: Hole Spacing for the Tool-less Rails in Relationship to a Rack Unit

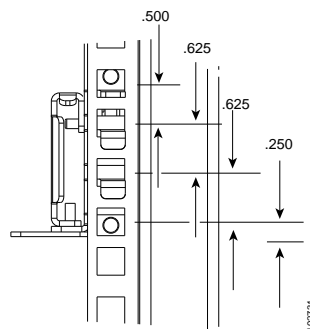

The following figure shows a rail mounted into a rack in the proper position with respect to a rack-unit boundary. Measurements are in inches between the centers of the holes.

Figure 25: Installing Tool-less Chassis Support Rails into the Rack

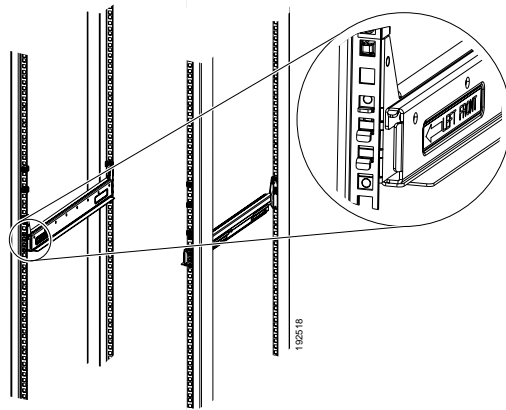

- Step 4** Press down firmly on the rail until the hooks seat firmly and securely into the holes, and the spring clip latches into place.
- Step 5** Follow the same procedure to install the other rack rail.
- Step 6** Use a tape measure and level to verify that the rack rails are horizontal and at the same height.
- Step 7** Insert the cage nuts on to the rack in the needed square holes as shown below. When the rails are installed on a rack unit boundary, the first two cage nuts are installed into the seventh holes above the rails' horizontal

plates. The next two cage nuts are installed into the fifth holes above the first cage nut. Finally, the two cage nuts are installed into the fourth holes above the second cage nuts.

Figure 26: Placement of Rails and Cage Nuts with Respect to the Rack Unit Boundary

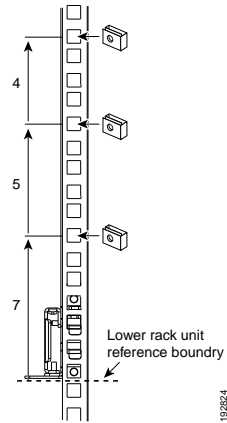
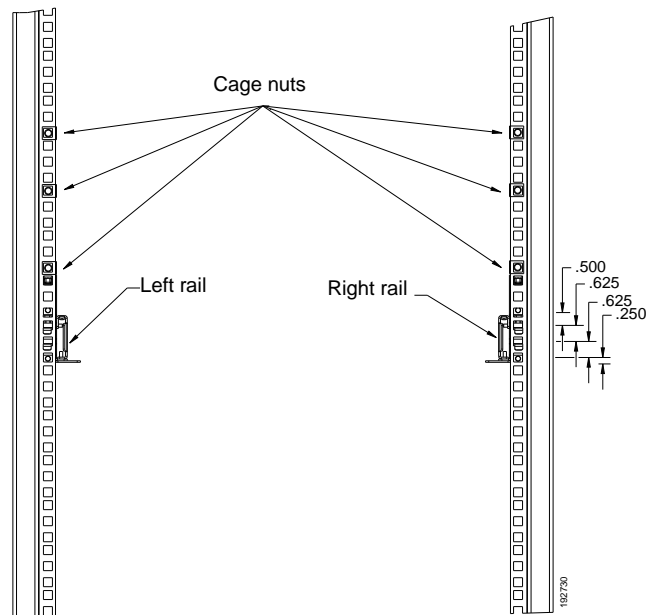

Figure 27: Proper Placement for the Rails and Cage Nuts



Step 8 Remove all power supplies, fan assemblies, server blades, and fabric extenders to lighten the chassis. Even with devices removed, the chassis weighs 90 lbs (40.83 kg).

Installing the Round Hole Adapter Kit

Before installing the chassis in a round hole rack, prepare the rails by adding the adapter kit according to the instructions in [Attaching the Round Hole Adapter Kit to the Rails \(Optional\)](#), on page 46.

Procedure

- Step 1** Remove the mounting template (Cisco 78-19093-01) from the accessory box. The template is designed to show you the proper holes within which the rails and cage nuts should be placed. Once the rack holes line up with the template, you should mark the holes so that their position is known after removing the template.
- Step 2** Adjust the length of the rail by sliding the ends of the rail back and forth until they match the depth of the rack.
- Step 3** Place the adapters and rails even with a rack boundary at each end of the rail.
- Step 4** Secure the rail to the rack with the provided pan head screws as shown below.

Figure 28: Attaching the Mounting Brackets to a Round Hole Rack

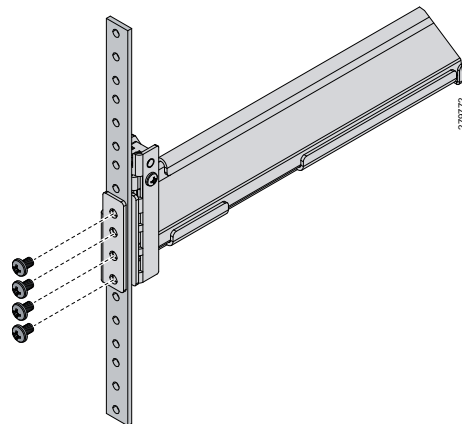

Step 5 Follow the same procedure to install the other rack rail as shown below.

Figure 29: Round Hole Adapter and Rails Installed in a Rack



Step 6 Use a tape measure and level to verify that both rack rails are horizontal and at the same height.

Step 7 Remove all power supplies, fan assemblies, server blades, and I/O modules to lighten the chassis. Even with devices removed, the chassis weighs 90 lbs (40.83 kg).

Inserting the Chassis into the Rack

Procedure

Step 1 With the help of another person (or special lifting equipment), lift the chassis and place it on the mounting rail as shown.

Figure 30: Mounting Rail Weight Distribution (Square Hole Mount Shown)

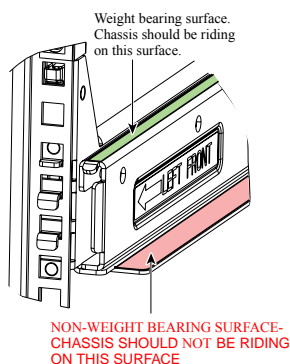

Caution The mounting rails may come loose and cause the chassis to fall if the weight is resting on the wrong surface. Make sure that the bottom of the chassis is resting on the correct rail surface.

- Step 2** Slide the chassis into the rack until the front flange is flat against the cage nuts. (Cage nuts are not needed in round hole racks.)
- Step 3** Using the six Phillips round washer head screws and the cage nuts (used in square hole installations), secure the chassis by its flanges to the rack as shown.

Figure 31: Securing the Chassis Into the Rack

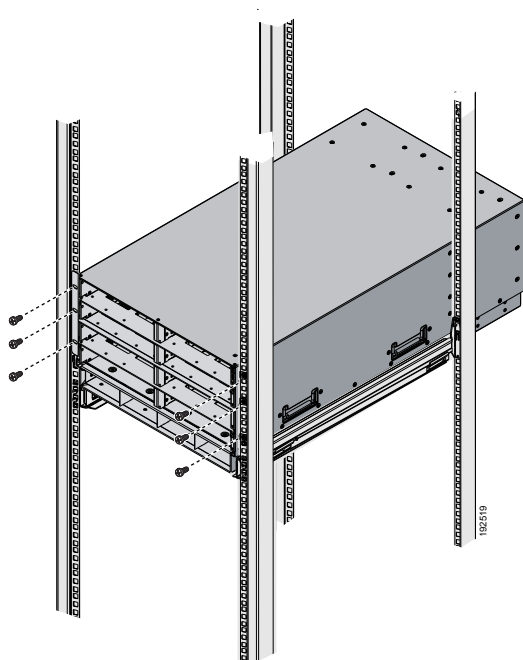

- Step 4** Replace all servers, fans, and power supplies back into their respective chassis slots.
- Step 5** To power up the chassis, connect the appropriate AC power cables to the inlet connector corresponding to each installed power supply, and then connect the other end of the cables to the power source. For a DC installation, see [Connecting a DC Power Supply, on page 54](#). To determine the number of power supplies needed for a given configuration, use the [Cisco UCS Power Calculator](#) tool.

Note Both grids in a power redundant system should have the same number of power supplies. If your system is configured for grid redundancy, slots 1 and 2 are assigned to grid 1 and slots 3 and 4 are assigned to grid 2. If only two power supplies (PS) are in a redundant-mode chassis, they should be in slots 1 and 3. Slot and cord connection numbering is shown below.

Figure 32: Power Supply Bay and Connector Numbering

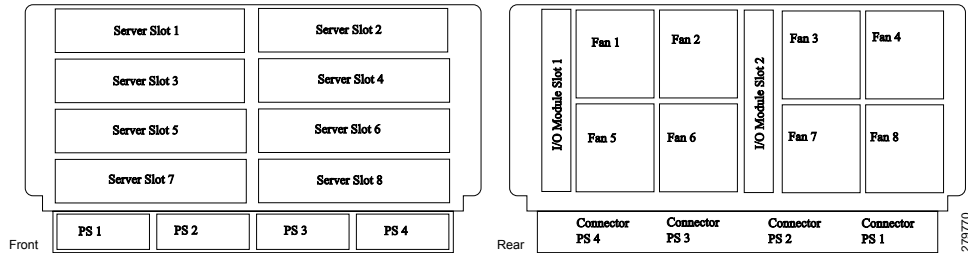

Step 6 Connect the server chassis to the fabric interconnect as described in [Proper FEX and Fabric Interconnect Port Connectivity](#), on page 58.

Connecting a DC Power Supply

This section describes how to connect power to the rear PDU terminals on the DC version chassis (UCSB-5108-DC) corresponding to a UCS 5108 DC power supply (UCSB-PSU-2500DC48).

Required Tools

You must have the following tools to perform this procedure:

- A Phillips screwdriver
- A 10-mm wrench or socket
- Connectors and wire for the DC circuit or circuits

DC Power Installation Procedure

Warning

When stranded wiring is required, use approved wiring terminations, such as closed-loop or spade-type with upturned lugs. These terminations should be the appropriate size for the wires and should clamp both the insulation and conductor. Statement 1002

Warning

Before performing any of the following procedures, ensure that power is removed from the DC circuit. Statement 1003

**Warning**

A readily accessible two-poled disconnect device must be incorporated in the fixed wiring. Statement 1022

**Warning**

Use copper conductors only. Statement 1025

**Warning**

This product requires short-circuit (overcurrent) protection, to be provided as part of the building installation. Install only in accordance with national and local wiring regulations. Statement 1045

**Warning**

When installing or replacing the unit, the ground connection must always be made first and disconnected last. Statement 1046

**Warning**

Installation of the equipment must comply with local and national electrical codes. Statement 1074

**Warning**

Hazardous voltage or energy may be present on DC power terminals. Always replace cover when terminals are not in service. Be sure uninsulated conductors are not accessible when cover is in place. Statement 1075

Procedure

- Step 1** Install the DC power supply in the chassis, making note of the bay number, so you are sure to connect the wiring to the appropriate terminals on the DC PDU at the chassis rear.
- Step 2** Verify that power is off to the DC circuit or circuits on the power supply that you are installing.
- Step 3** Ensure that all site power and grounding requirements have been met.
- Step 4** Remove the plastic cover from the DC terminals by squeezing the flanges at the top and bottom of the cover.
- Step 5** Connect the ground wires to the power supply terminal block, shown as a green wire below. Only one ground connection is required, though there may be up to four DC connections.
- Step 6** Connect the DC-input wires to the power supply terminal block. The proper wiring sequence is positive to positive (red wire), and negative to negative (black wire). The figure below shows a connection to terminal 1.

Note The positive and negative wires can be installed pointing either to the right or to the left as long as the terminal cover is used. The figure below shows them pointed to the right. Panduit LCD4-14A-L connectors may be used for the supply and return wires, and Panduit LCD4-14AF-L or equivalent connectors may be used for the 90-degree ground lug wire. Both connections have double lugs with .25 inch holes measuring .625 inches from center to center.

Figure 33: Connecting DC Power to the Chassis (shows DC PDU only, Chassis is Omitted)

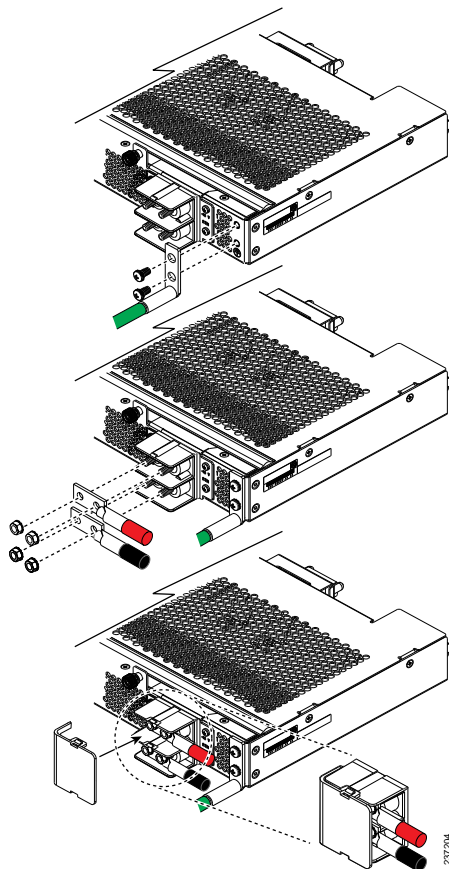

- Step 7** Replace the terminal cover as shown. This cover should always be in place when power is applied to the terminals.
- Step 8** Connect the other end of the power wires to a DC-power input source.
- Step 9** Set the DC disconnect switch in the circuit to ON.
- Caution** In a system with multiple power supplies, connect each power supply to a separate DC power source. In the event of a power source failure, if the second source is still available, it can maintain system operation.
- Step 10** Verify power supply operation by checking the power supply's front-panel LEDs. You should see the following:
- The LED labeled INPUT OK is green.
 - The LED labeled OUTPUT FAIL is not lit.

- Step 11** Check the power supply and system status from the UCS console by entering the show system command or the show power command, do using the GUI. For more information on these commands, refer to the command reference for your software.

Cabling Considerations for Fabric Port Channels

When you configure the links between the Cisco UCS 2200 Series FEX and a Cisco UCS 6200 series fabric interconnect in fabric port channel mode, the available VIF namespace on the adapter varies depending on where the FEX uplinks are connected to the fabric interconnect ports.

Inside the 6248 fabric interconnect there are six sets of eight contiguous ports, with each set of ports managed by a single chip. When uplinks are connected such that all of the uplinks from an FEX are connected to a set of ports managed by a single chip, Cisco UCS Manager maximizes the number of VIFs used in service profiles deployed on the blades in the chassis. If uplink connections from an IOM are distributed across ports managed by separate chips, the VIF count is decreased.

Figure 34: Port Groups for Fabric Port Channels

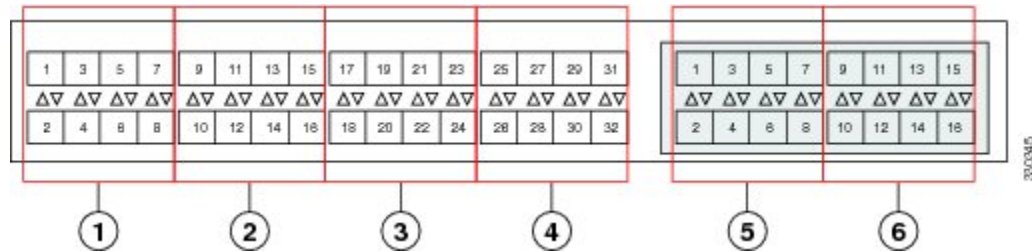

Caution

Adding a second link to a fabric port channel port group is disruptive and will automatically increase the available amount of VIF namespace from 63 to 118. Adding further links is not disruptive and the VIF namespace stays at 118.



Caution

Linking a chassis to two fabric port channel port groups is disruptive and does not affect the VIF namespace unless it is manually acknowledged. The VIF namespace is then automatically set to the smaller size fabric port channel port group usage (either 63 or 118 VIFs) of the two groups.

For high availability cluster mode applications, symmetric cabling configurations are strongly recommended. If the cabling is asymmetric, the maximum number of VIFs available is the smaller of the two cabling configurations.

For more information on the maximum number of VIFs for your Cisco UCS environment, see the configuration limits document for your hardware and software configuration.

Proper FEX and Fabric Interconnect Port Connectivity



Note

The following illustrations are for example only; you do not need to skip available ports to provide future expansion room. See the UCS Manager configuration guide for FI port configuration considerations and limitations.

Observe the following guidelines:

- When you connect the server chassis to the fabric interconnect, do not connect the FEXes to the fabric interconnect's expansion modules. While similar in appearance to the other ports on the fabric interconnect, the expansion modules are never used for direct chassis connections. They are typically used for SAN connectivity or network uplink.
- All ports of a FEX must be connected to only one fabric interconnect. You must connect each fabric interconnect to the chassis through its own FEX.
- If you need to connect to a second fabric interconnect, do the following:
 - The chassis must have a second FEX installed.
 - All ports of the second FEX must be connected to the second fabric interconnect only because the FEX is a fabric extender, which can only be connected to a single switch, or in this case, a fabric interconnect.

The following figure shows an invalid connection from a FEX to two separate fabric interconnects.

Figure 35: Invalid Connection for the Server Chassis and two Cisco UCS 6120XP Fabric Interconnects

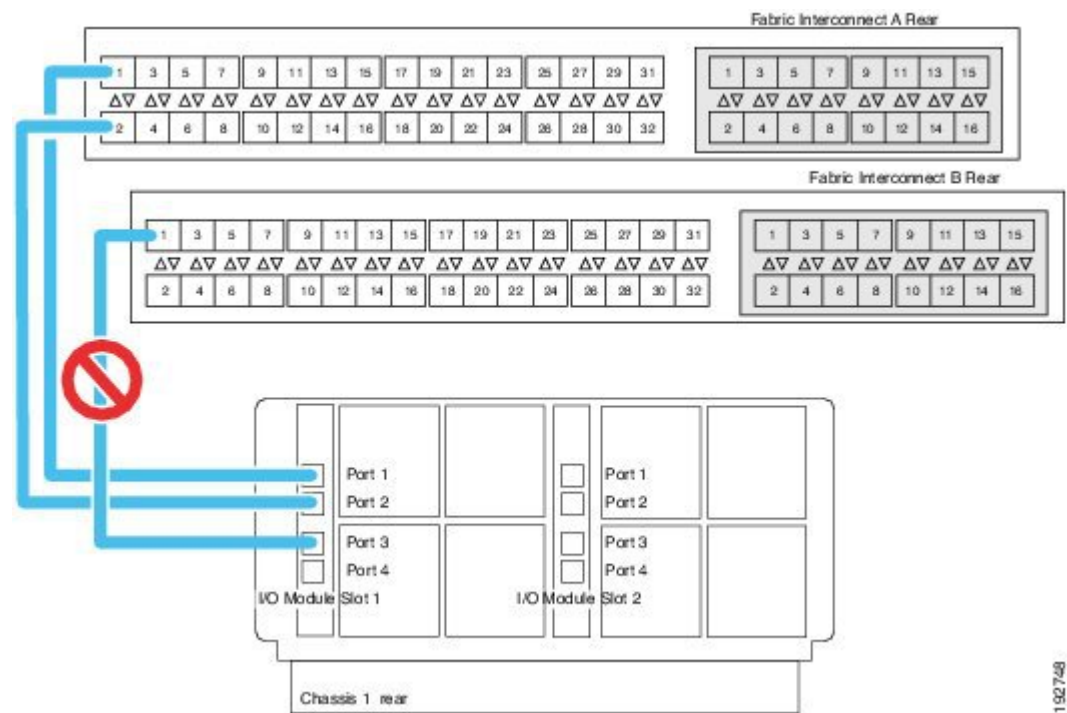

- Both fabric interconnects should be wired identically: if port 1 on FEX 1 for a chassis goes to FI-A port 5, then port 1 on FEX 2 goes to FI-B port 5.

The following figure shows valid connections from FEXes in two chassis to two separate fabric interconnects. When you connect the server chassis to the fabric interconnect do not connect the FEXes to the fabric interconnect's expansion modules. While similar in appearance to the other ports on the fabric interconnect, the expansion modules are never used for direct chassis connections, they are used for uplink or SAN connections.

Figure 36: Proper Connection for the Server Chassis and two Cisco UCS 6120XP Fabric Interconnects

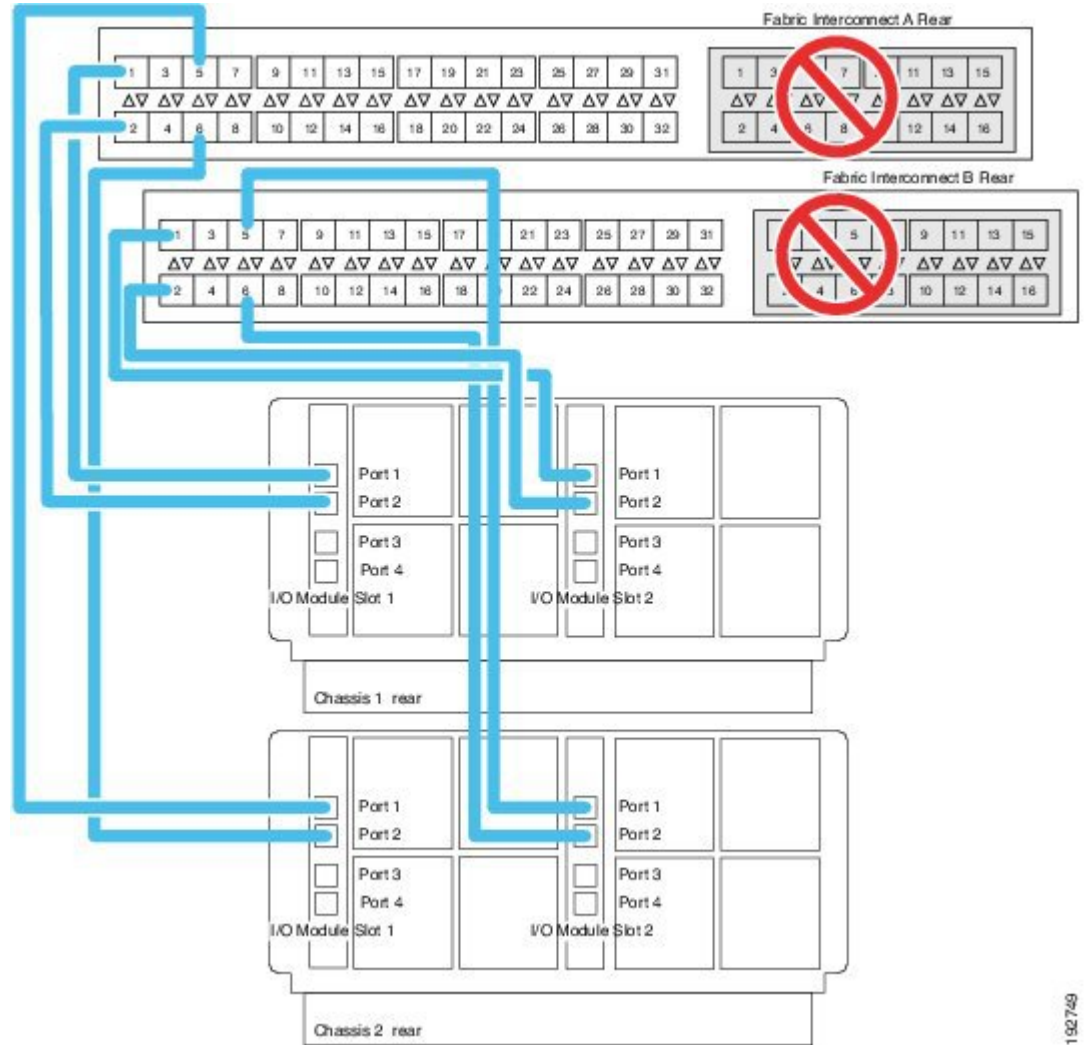

192749

Removing the Chassis from a Rack

Procedure

Step 1 Use Cisco UCS Manager to do the following:

- a) Shut down the OS on all blade servers in the chassis.
- b) Disable the Smart Call Home feature.
- c) Decommission the chassis.

For details, see the *Configuration Guide* for the version of Cisco UCS Manager that you are using. The configuration guides are available at the following URL: http://www.cisco.com/en/US/products/ps10281/products_installation_and_configuration_guides_list.html

Step 2 Disconnect the power cords and networking cables from the chassis.

Step 3 Remove all modules and blades from the chassis to lighten its weight.

Step 4 Remove the screws holding the front rack-mount flange to the rack.

Step 5 With two people holding the chassis, make sure that its weight is fully supported.

Step 6 Gently slide the chassis off the rails, and out of the rack.

Step 7 Replace the modules and blades in the server chassis.

Repacking the Chassis

If you need to repack the chassis, remove it from the rack by reversing the steps in the [Removing the Chassis from a Rack](#), on page 60 section, and then pack it for shipment. If possible, use the original packing materials and container to pack the chassis. Replacement packaging can be ordered using the following PIDS:

- If you have only half-width blades, use UCSB-5108-PKG-HW=.
- If you have full-width blades or a mix of full-width and half-width blades, use UCSB-PKG-FW=.

If you are returning the chassis to Cisco, contact your Cisco customer service representative to arrange for return shipment to Cisco.

SFP+ Transceivers

Each FEX within the chassis supports Small Form-Factor Pluggable (SFP+) copper or optical transceivers. Each transceiver runs at 10 Gb.

SFP+ Twinax Copper Transceivers

The FEX also supports Twinax copper transceivers. The enhanced SFP+ 10-Gb Ethernet transceiver is a bidirectional device with a transmitter and receiver in the same physical package. It has a 20-pin connector on the electrical interface.

Table 9: SFP+ 10 Gb Ethernet Transceiver

Model	Description
SFP-H10GB-CU1M	10-Gb Ethernet—copper SFP+ (1 m, 3.28 ft.)
SFP-H10GB-CU3M	10-Gb Ethernet—copper SFP+ (3 m, 9.84 ft.)
SFP-H10GB-CU5M	10-Gb Ethernet—copper SFP+ (5 m, 16.4 ft.)
SFP-H10GB-ACU7M	10-Gb Ethernet—copper SFP+ (7 m, 22.9 ft.)
SFP-H10GB-ACU10M	10-Gb Ethernet—copper SFP+ (10 m, 32.8 ft.)

The figure below shows the SFP-H10GB-CU5M transceiver. The rubber loop is used for removing the SFP+ from its port on the I/O module.

Figure 37: SFP+ 10 Gb Twinax Copper Transceiver

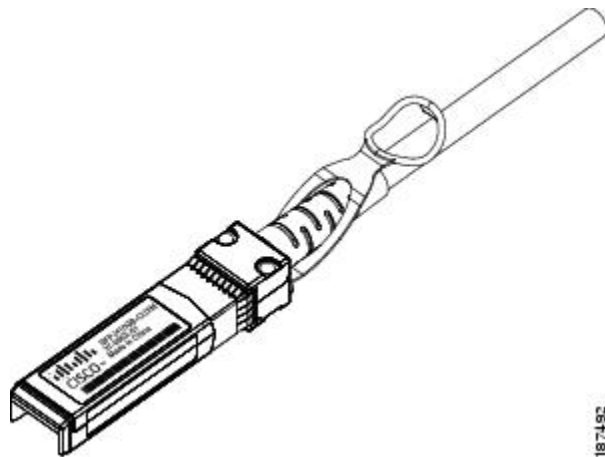

Optical SFP+ Transceivers

If distances greater than 10 meters (33 feet) must be spanned, the FEX also supports the substitution of the copper SFP+ by optical SFP+ transceivers. The SFP+ 10-Gb Ethernet optical transceiver is a bidirectional device with a transmitter and receiver in the same physical package. It has a duplex LC connector on the optical interface.

Model	Description
SFP-10G-SR	Short-range optical SFP+ (up to 300 m/ 984 feet)
SFP-10G-LR ⁴	Long-range optical SFP+ (up to 10 km/6.2 miles)

Model	Description
FET-10G	Cisco 10G Fabric Extender Transceiver, LC duplex connector

- ⁴ While the SFP-10G-LR is supported by both the fabric interconnect and I/O module, the maximum distance will introduce latency issues that will affect overall performance.

Documentation for SFP+ 10-Gb Ethernet optical transceivers is at

http://www.cisco.com/en/US/docs/interfaces_modules/transceiver_modules/installation/note/78_15160.html

SFP and SFP+ Transceivers for the UCS 6324 Fabric Interconnect

Each UCS 6324 Fabric Interconnect supports up to four SFP optical or copper transceivers.

Table 10: SFP+ Transceivers

Model	Description
SFP-10G-SR	Short-range optical SFP+ (up to 300 m/ 984 feet)
SFP-10G-SR -X	Short-range optical SFP+ (up to 300 m/ 984 feet), extended temperature
FET-10G	Cisco 10G Fabric Extender Transceiver, LC duplex connector

Table 11: SFP Optical Transceivers

Model	Description
GLC-T	1-Gb Ethernet copper SFP module
GLC-SX-MM	1-Gb Ethernet short-range (up to 550 m / 1804.46 feet) SFP module
GLC-LH-SM	1-Gb Ethernet long-range (10 km / 32808.4 feet) SFP module
SFP-GE-T	1-Gb Ethernet extended temperature range module

The UCS 6324 Fabric Interconnect also supports Twinax copper transceivers. The enhanced SFP+ 10-Gb Ethernet transceiver is a bidirectional device with a transmitter and receiver in the same physical package. It has a 20-pin connector on the electrical interface.

Table 12: SFP+ 10 Gb Ethernet Transceivers

Model	Description
SFP-H10GB-CU1M	10-Gb Ethernet—copper SFP+ (1 m, 3.28 ft.)
SFP-H10GB-CU3M	10-Gb Ethernet—copper SFP+ (3 m, 9.84 ft.)
SFP-H10GB-CU5M	10-Gb Ethernet—copper SFP+ (5 m, 16.4 ft.)
SFP-H10GB-ACU7M	10-Gb Ethernet—copper SFP+ (7 m, 22.9 ft.)
SFP-H10GB-ACU10M	10-Gb Ethernet—copper SFP+ (10 m, 32.8 ft.)

Twinax Copper Cables for the UCS 6324 Fabric Interconnect

Twinax copper cables are available in various lengths for the UCS 6324 Fabric Interconnect. The 7 meter and 10 meter cables are active, which means that they contain active components with the SFP+ connector housing to improve signal quality. The ends of these cables have connectors that can plug directly into SFP receptacles.

Table 13: Twinax Copper Cables

Model	Description
SFP-H10GB-CU1M	10-Gb Ethernet—copper SFP+ (1 m, 3.28 ft.)
SFP-H10GB-CU3M	10-Gb Ethernet—copper SFP+ (3 m, 9.84 ft.)
SFP-H10GB-CU5M	10-Gb Ethernet—copper SFP+ (5 m, 16.4 ft.)
SFP-H10GB-ACU7M	10-Gb Ethernet—copper SFP+ (7 m, 22.9 ft.)
SFP-H10GB-ACU10M	10-Gb Ethernet—copper SFP+ (10 m, 32.8 ft.)

QSFP+ Copper Optical Transceivers for the UCS 6324 Fabric Interconnect

Each UCS 6324 Fabric Interconnect supports up one copper/optical transceiver.

Table 14: QSFP+ Copper/Optical Transceivers

Model	Description
QSFP-4SFP10G-CU5M	40GBASE-CR4 QSFP+ to four 10GBASE-CU SFP+ direct attach breakout cable assembly, 5 meter passive

Model	Description
QSFP-4SFP10G-CU3M	40GBASE-CR4 QSFP+ to four 10GBASE-CU SFP+ direct attach breakout cable assembly, 3 meter passive
QSFP-4SFP10G-CU1M	40GBASE-CR4 QSFP+ to four 10GBASE-CU SFP+ direct attach breakout cable assembly, 1 meter passive
QSFP-4x10G-AC7M	40GBASE-CR4 QSFP+ to four 10GBASE-CU SFP+ direct attach breakout cable assembly, 7 meter active
QSFP-4x10G-AC10M	40GBASE-CR4 QSFP+ to four 10GBASE-CU SFP+ direct attach breakout cable assembly, 10 meter active

Replacing a Copper Twinax SFP+ Transceiver with an Optical SFP+ Transceiver

Procedure

- Step 1** Remove the copper Twinax SFP+ from the FEX port by pulling gently on the rubber loop. The cable and SFP+ transceiver come out as a single unit, leaving the FEX port empty.

Figure 38: Removing a Twinax Copper SFP+ Transceiver

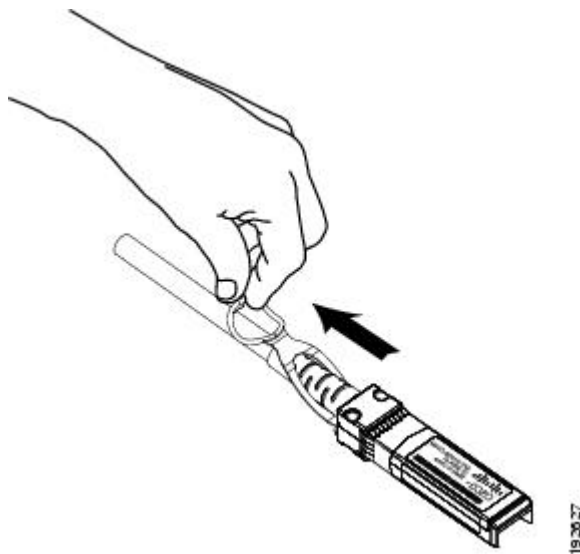

- Step 2** Insert the optical SFP+ transceiver into the FEX port. Make sure that it clicks firmly into place.
- Step 3** Plug the fiber-optic cable into the optical SFP+ transceiver.

Figure 39: Replacing a Copper SFP+ Transceiver with an Optical SFP+ Transceiver

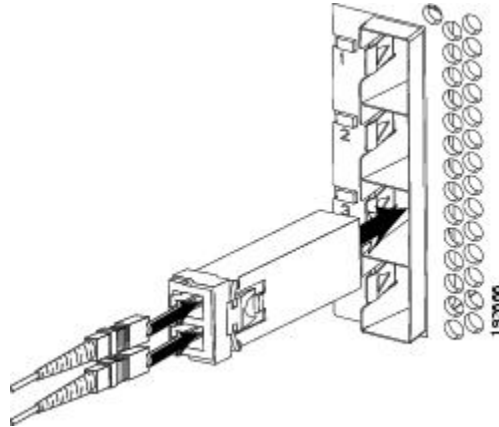



Installing and Removing Components

This chapter describes how to remove components from the chassis and how to install components into the chassis. This section contains the following section:

- [Components, page 67](#)
- [Installing and Removing a Blade Server, page 69](#)
- [Installing and Removing Power Supplies, page 71](#)
- [Installing and Removing a Power Distribution Unit \(PDU\), page 73](#)
- [Installing and Removing a FEX or Fabric Interconnect, page 75](#)
- [Migrating to UCS 6300 Series Fabric Interconnects and the UCS 2304 IOM, page 77](#)
- [Installing and Removing a Fan Module, page 80](#)

Components

The following figure shows an empty Cisco UCS 5108 server chassis and identifies the front, back, and module slots.

**Note**

Whenever you remove a module from the chassis for an extended period of time, always replace the module with the appropriate blank panel. Failing to do so can result in heating and EMI issues. Blank panels can be ordered from Cisco Systems.

Figure 40: View of Cisco UCS 5108 Server Chassis

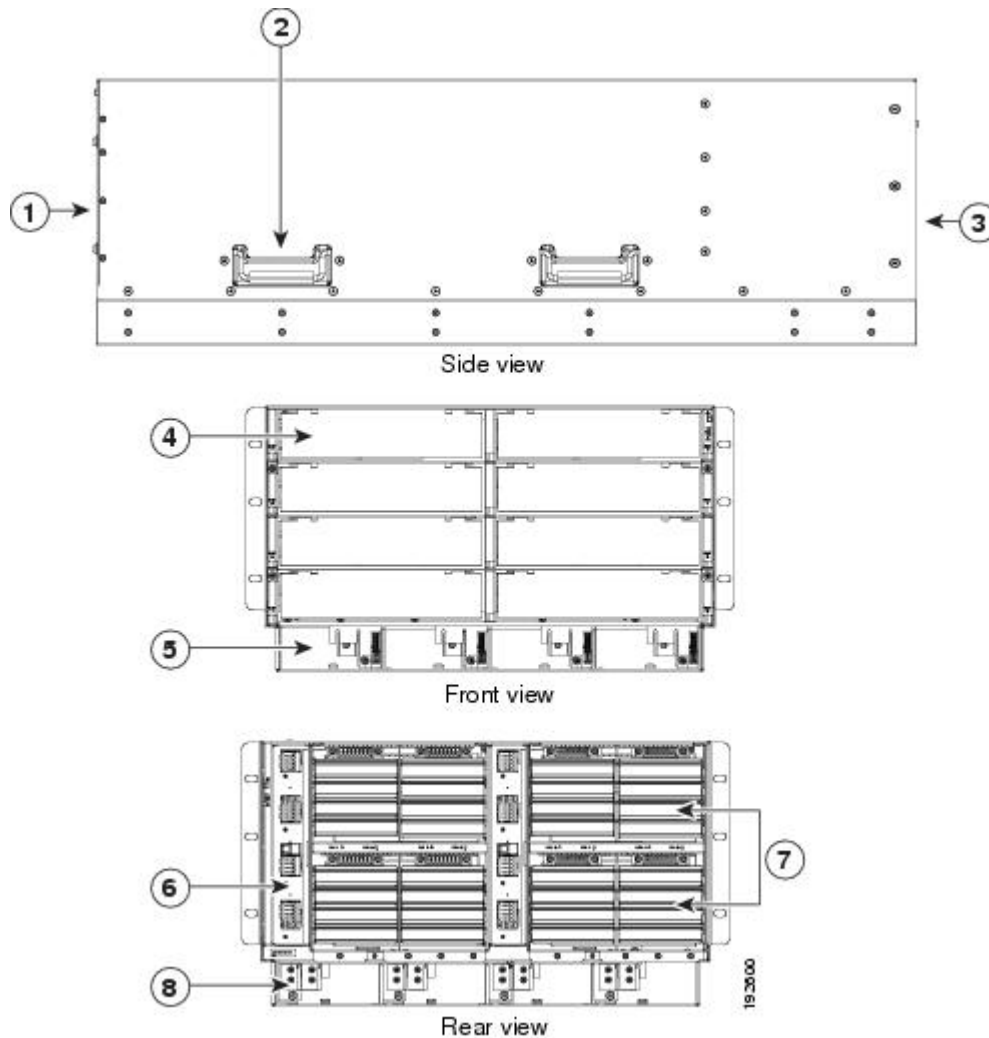

1	Front of chassis	5	Power supply slot (4 slots)
2	Chassis handle	6	Fabric interconnect or FEX slot (2 slots)
3	Rear of chassis	7	Fan slots (8 slots)
4	Half-width server slot (8 slots)	8	Power Distribution Unit (PDU) slot

**Note**

Before you install, operate, or service the system, see the [Regulatory Compliance and Safety Information for Cisco UCS](#) for important safety information.

**Warning****IMPORTANT SAFETY INSTRUCTIONS**

This warning symbol means danger. You are in a situation that could cause bodily injury. Before you work on any equipment, be aware of the hazards involved with electrical circuitry and be familiar with standard practices for preventing accidents. Use the statement number provided at the end of each warning to locate its translation in the translated safety warnings that accompanied this device. Statement 1071

SAVE THESE INSTRUCTIONS**Warning**

This unit is intended for installation in restricted access areas. A restricted access area can be accessed only through the use of a special tool, lock and key, or other means of security. Statement 1017

**Warning**

Only trained and qualified personnel must be allowed to install, replace, or service this equipment. Statement 1030

Installing and Removing a Blade Server

There are two types of blade server supported, half-width and full-width. Their installation is similar but with important differences. For details, see the *Blade Server Installation and Service Note* for the type of blade server you are using. The server notes are available at the following URL: http://www.cisco.com/en/US/products/ps10280/prod_installation_guides_list.html

Installing and Removing a Blade Server Hard Drive

You can remove blade server hard drives without removing the blade server from the chassis. All other component replacement for a blade server requires removing the blade from the chassis. Unused hard drive bays should always be covered with cover plates (N20-BBLKD) to assure proper cooling and ventilation. The chassis is omitted from illustrations here to simplify the drawing.

**Caution**

To prevent ESD damage, wear grounding wrist straps during these procedures and handle modules by the carrier edges only.

Installing a Blade Server Hard Drive

Procedure

-
- Step 1** Place the hard drive lever into the open position by pushing the release button.
 - Step 2** Gently slide the hard drive into the opening in the blade server until it seats into place.
 - Step 3** Push the hard drive lever into the closed position.
-

The following figure shows the positioning of a hard drive within a blade server.

Figure 41: Positioning a Hard Drive in a Blade Server (Cisco UCS B200 M1 shown)

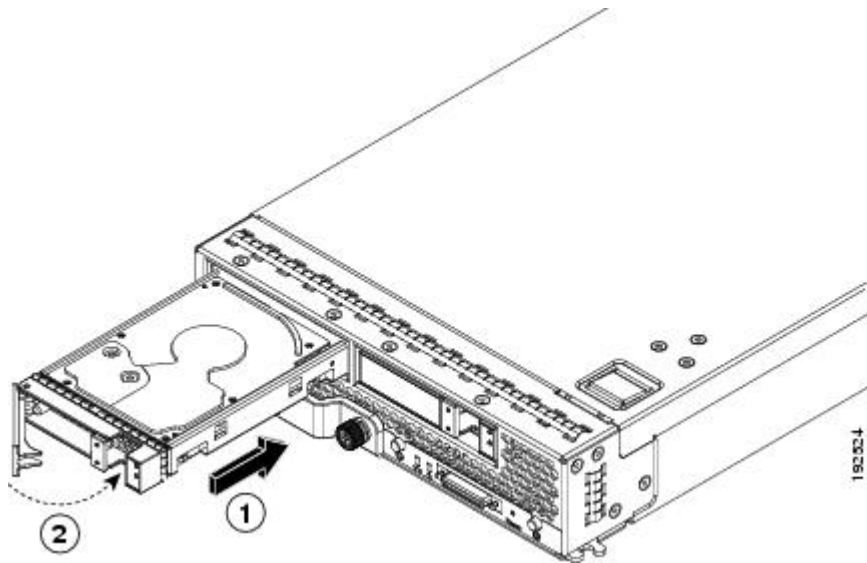

Removing a Blade Server Hard Drive

Procedure

- Step 1** Push the button to release the ejector, and then pull the hard drive from its slot.

Figure 42: Pressing the Button on the Front of the Hard Drive to Deploy the Lever (Cisco UCS B200 M1 shown)

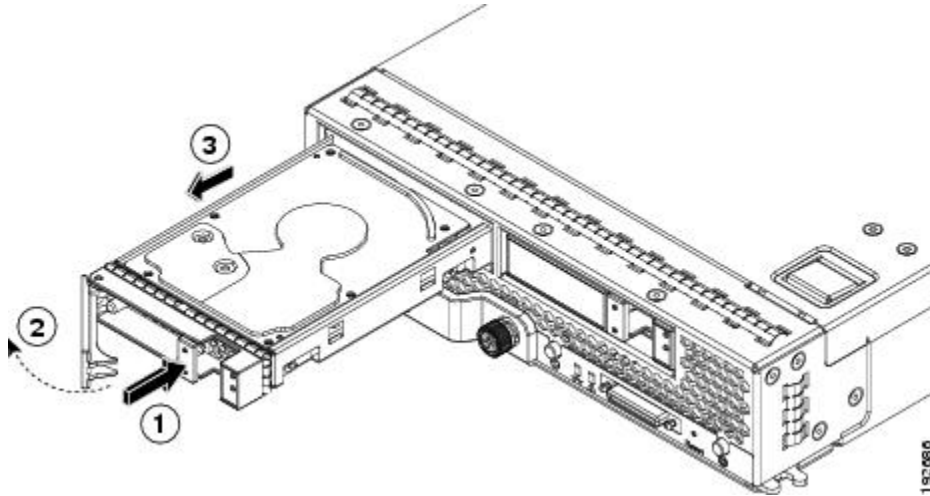

1	Release button	2	Hard drive lever
---	----------------	---	------------------

- Step 2** Place the hard drive on an antistatic mat or antistatic foam if you are not immediately reinstalling it in another blade server.
- Step 3** Install a blank faceplate (N20-BBLKD) to keep dust out of the blade server if the slot will remain empty.

Installing and Removing Power Supplies



Note

The AC and DC power supplies are keyed to work only with the power distribution system in their respective chassis version. Mixing AC and DC in a given chassis is not supported.

Installing a Power Supply

All power supply models (N20-PAC5-2500W, UCSB-PSU-2500ACPL, or UCSB-PSU-2500DC48) install using the same process.

Procedure

-
- Step 1** Place the power supply's handle in the up position.
- Step 2** Hold the power supply with both hands, and then slide it into the power supply bay,
- Step 3** Press the handle down, and give the power supply a gentle push inward to ensure that the power supply is fully seated into the Power Distribution Unit (PDU).
- Step 4** Tighten the captive screw.
- Step 5** For an AC installation, plug the power cable into the corresponding 220 VAC-inlet connector on the PDU at the rear of the chassis. For a DC environment, see [Connecting a DC Power Supply, on page 54](#).
- Note** Depending on the outlet receptacle on your rack's power distribution unit, you may need the optional jumper power cord to connect the Cisco UCS 5108 server chassis to an outlet receptacle.
- Step 6** Connect the other end of the power cable to the AC-power source.
- Step 7** Verify the power supply is operating by checking the power supply LEDs. See [LED Locations, on page 35](#) and [Interpreting LEDs, on page 36](#).

Figure 43: Positioning a Power Supply in the Cisco UCS Server Chassis

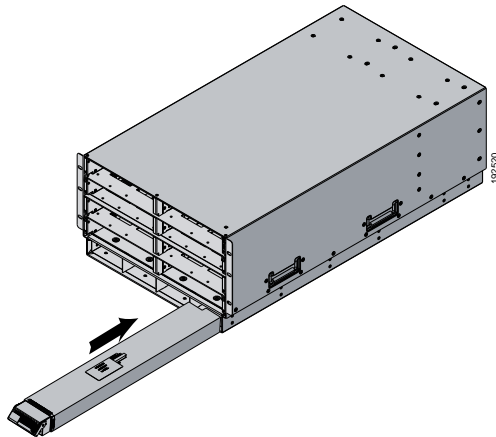

- Note** Both grids in a power redundant system should have the same number of power supplies. If your system is configured for grid redundancy, slots 1 and 2 are assigned to grid 1 and slots 3 and 4 are assigned to grid 2. If there are only two power supplies in a redundant-mode chassis, they should be in slots 1 and 3. This would be a very unusual configuration, with a single B200 blade server in the chassis. A larger configuration would require two power supplies per grid. Slot and cord connection numbering is shown below.

Figure 44: Power Supply Bay and Connector Numbering (AC Version Shown)

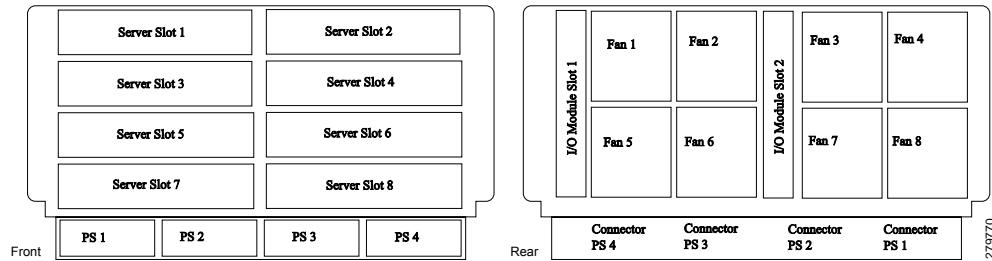

Removing a Power Supply



Caution

If you are using the Cisco UCS 5108 server chassis with one power supply (this is only supported in earlier versions of the system software), removing the power supply will cause the servers and chassis to shut down. If you are using more than two power supplies, and you remove one of them, the servers continue to operate as long as the other power supplies are sufficient to meet the power requirements of the number of servers in the chassis.

Procedure

- Step 1** Loosen the captive screw on the front of the power supply.
- Step 2** Lift up the power supply's handle to unseat the power supply.
- Step 3** Using the lever, pull the power supply from its slot. Place your other hand under the power supply to support it while you slide it out of the chassis.
- Step 4** Install a blank power supply filler panel (N20-CBLKP) if the power supply bay is to remain empty.

Installing and Removing a Power Distribution Unit (PDU)



Caution

The Power Distribution Unit should only be replaced by a Cisco certified technician. This section is for reference only.



Caution

You can not hot swap a PDU (N01-UAC1). The entire chassis will need to be shut down and all power cords should be unplugged before attempting this procedure.

Installing a PDU

Procedure

- Step 1** Hold the PDU module from below, with the captive screws at the top of the module.

Figure 45: Positioning a PDU (N01-UAC1) in the Cisco UCS Server Chassis, AC Version

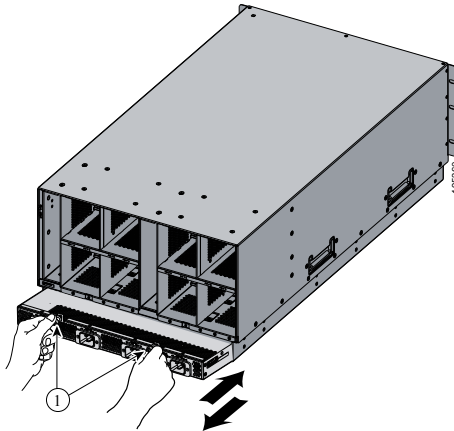

- Step 2** Push the PDU module into the chassis until it seats properly. If power supplies are installed, you may need to partially remove them.
- Step 3** Tighten the captive screws.
- Step 4** If necessary, reseal the power supplies and restart the system to observe LED behavior.
-

Removing a PDU

Procedure

- Step 1** Partially remove all installed power supplies. If a power supply is seated into the PDU, removal is difficult or impossible.
- Step 2** Loosen the captive screws.
- Step 3** Pull the PDU clear of the chassis by pulling on the captive screws. Support its weight from below.
-

Installing and Removing a FEX or Fabric Interconnect

The chassis houses two IOM (FEX) modules that allow the blade servers in the chassis to communicate with Cisco UCS fabric interconnects. For the Cisco UCS 2100 Series, the model is Cisco UCS 2104XP. For the Cisco UCS 2200 Series, the models are UCS 2208XP and UCS 2204XP. For the Cisco UCS 2300 Series, the model is the Cisco UCS 2304 IOM.

**Note**

The Cisco UCS 2304 IOM cannot be installed in the same chassis with a UCS 2208XP or UCS 2204XP IOM except during migration.

The same slot that is used for a FEX is used for the Cisco UCS 6324 Fabric Interconnect. Up to two of these modules can be installed in the chassis.

UCS 2104 to UCS 2200 Series FEX Upgrade Considerations

Before you install a pair of UCS 2208XP FEXes to an existing UCS chassis using a pair of UCS 2104XPs, or add a new chassis with a pair of UCS 2208XP FEXes to a UCS instance you must perform a full upgrade to UCS software version 2.0(1) or later. The UCS 2208XP FEX is not recognized by earlier software releases.

Before you install a pair of UCS 2204XP FEXes to an existing UCS chassis using a pair of UCS 2104XPs, or add a new chassis with a pair of UCS 2204XP FEXes to a UCS instance you must perform a full upgrade to UCS software version 2.0(2) or later. The UCS 2204XP I/O Module is not recognized by earlier software releases.

Upgrading from a pair of UCS 2104XP to a pair of UCS 2200 series modules should be done first on the FEX connected to the standby Fabric Interconnect, standby should be made active, then the FEX connected to the new standby Fabric Interconnect can be upgraded.

If you are also performing an upgrade on the fabric interconnects, perform the upgrades separately. Attempting to upgrade both FEXes and fabric interconnects in a single process will likely complicate any reconfiguration needed on the FI ports.

Adding any M3 model blade server may require an upgrade from UCS 2104XP to UCS 2208 series FEXes. M3 blade servers use newer MLOM and adapter card models that are not fully compatible with the older FEX model.

Before you disconnect any data cables, make a record of which FEX ports are connected to which Fabric interconnect ports.

Configurations of 1, 2, 4, or 8 10 GB connections between FEX and Fabric interconnect are supported in UCS. If your UCS 2104XP has 4 physical connections and you want more, the next available upgrade step is the full 8 connections on the UCS 2208XP. You should verify that the FEX upgrade is completed with no problems before adding the connections for ports 5-8.

If you intend to implement the Fabric port channel feature available in UCS software version 2.0, you may need to rearrange the cabling between FEX and Fabric Interconnect before performing the feature configuration. Fabric port channel will require that all physical links from a given FEX physically connect to a contiguous block of ports (1 to 8 or 9 to 16, and so on). This feature requires a Cisco UCS M82-8P Virtual Interface Card in at least one blade server, and a UCS 2200 Series I/O module that is connected to a UCS 6200 Series Fabric Interconnect. See the Fabric Port Channel sections in the configuration guides for more details.

Removing a FEX or UCS 6324 Fabric Interconnect

Procedure

-
- Step 1** Remove all cables from the FEX or UCS 6324 Fabric Interconnect.
 - Step 2** Loosen the captive screws on the FEX or UCS 6324 Fabric Interconnect.
 - Step 3** Pull the levers outward to unseat the FEX or UCS 6324 Fabric Interconnect.
 - Step 4** Using the levers, pull the FEX or UCS 6324 Fabric Interconnect from its slot.
 - Step 5** Install a blank FEX filler panel (N20-CBLKI) if the FEX or fabric interconnect slot is to remain empty.
- Note** If you plan to remove a FEX or UCS 6324 fabric interconnect for an extended period of time, you must replace it with the N20-CBLKI blank to avoid EMI issues. Blanks can be order from Cisco.
-

Installing a FEX or Fabric Interconnect

Procedure

-
- Step 1** Make sure that the two levers at the front of the FEX or the UCS 6324 Fabric Interconnect are pulled open.
 - Step 2** Slide the FEX or UCS 6324 Fabric Interconnect into the chassis slot, ensuring that the module is fully seated.

Figure 46: Positioning a FEX or Fabric Interconnect within the Server Chassis

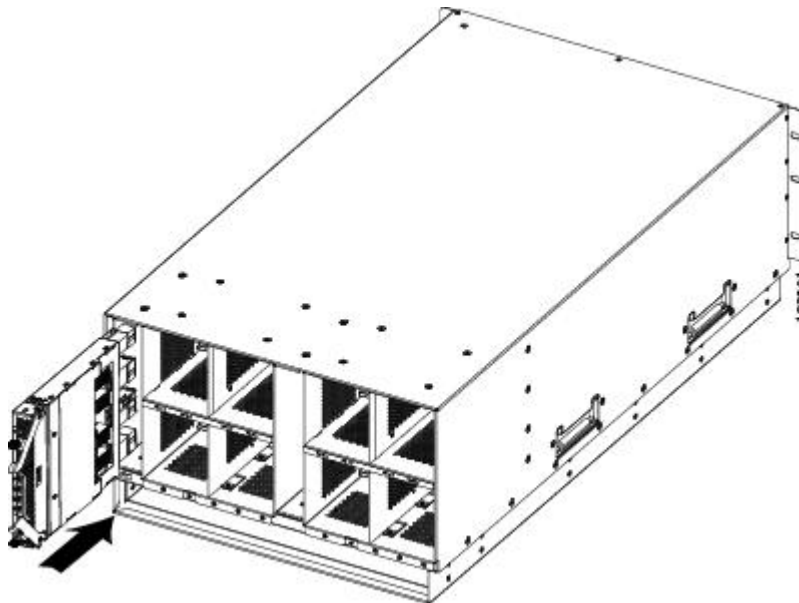

- Step 3** Close the levers and tighten the captive screw on each lever.
- Step 4** Connect the networking cables (see [SFP+ Transceivers](#), on page 60 and [Proper FEX and Fabric Interconnect Port Connectivity](#), on page 58).
- Step 5** Verify that the module is functioning correctly. See [LED Locations](#), on page 35 and [Interpreting LEDs](#), on page 36.
-

Migrating to UCS 6300 Series Fabric Interconnects and the UCS 2304 IOM

You can migrate from a UCS 6200 Series Fabric Interconnect to a UCS 6300 Series Fabric Interconnect. You can also revert back to UCS 6200 Series Fabric Interconnect after you have migrated to a UCS 6300 Series Fabric Interconnect.

You cannot migrate from a UCS 6100 Series Fabric Interconnect to a UCS 6300 Series Fabric Interconnect.

Before You Begin

Before starting the hardware migration, make the following changes to Cisco UCS Manager software:

- Download Cisco UCS Manager, Release 3.1 to the UCS 6200 Series Fabric Interconnects and upgrade to this version.
- Download Cisco UCS Manager, Release 3.1 to the UCS 6300 Series Fabric Interconnects.
- Ensure that all fabric interconnects have the same versions of the kickstart, system, and UCS Manager images.
- Upgrade the B-bundle if you plan to use the UCS 2304 IOM.
- If you plan to migrate to a UCS 6332-16UP Fabric Interconnect, determine the number of VSANs that are configured in your system. If more than 15 VSAN IDs are configured, reduce this number to 15 or less to avoid possible configuration issues with Fibre Channel or FCoE ports on a UCS 6332-16UP Fabric Interconnect. It is not necessary to reduce the number of configured VSANs before migrating to a UCS 6332 Fabric Interconnect.

Migrating Fabric Interconnect Modules

The steps in this section apply to the following scenarios:

- Migrating from a UCS 6248 Fabric Interconnect to a UCS 6332 Fabric Interconnect with a UCS 2204 or UCS 2208 IOM, 2 to 3 tuple
- Migrating from a UCS 6248 Fabric Interconnect to a UCS 6332-16UP Fabric Interconnect with a UCS 2304 IOM
- Migrating from a UCS 6296 Fabric Interconnect to a UCS 6332 Fabric Interconnect with a UCS 2204 or UCS 2208 IOM, 2 to 3 tuple
- Migrating from a UCS 6296 Fabric Interconnect to a UCS 6332-16UP Fabric Interconnect with a UCS 2304 IOM



Note Following a migration, remove port-related configurations in the fabric interconnect and then reconfigure the ports. For example, you must reconfigure the SPAN destination ports after migrating from a UCS 6200 Series Fabric Interconnect to a UCS 6300 Series Fabric Interconnect.



Note As stated in the Prerequisites, make sure that you reduce the number of configured VSANs in your UCS system to 15 or less before you begin the migration, if you plan to migrate to a UCS 6332-16UP Fabric Interconnect. It is not necessary to reduce the number of configured VSANs before migrating to a UCS 6332 Fabric Interconnect.

Use Cisco UCS Manager, either the GUI or the CLI, to perform the following software-related tasks. For additional information, refer to the *Cisco UCS Manager Getting Started Guide*, the *Cisco UCS Manager Infrastructure Management Guide*, and the instructional videos available at this URL: <http://www.cisco.com/c/en/us/support/servers-unified-computing/ucs-manager/products-installation-and-configuration-guides-list.html>

Procedure

- Step 1** Ensure that vNIC failover is enabled in the service profile.
 - Step 2** Enable **Configuration Evacuation** in the subordinate fabric interconnect.
 - Step 3** Remove the configuration from the ports in the subordinate fabric interconnect.
 - Step 4** Remove the cables that are between the subordinate fabric interconnect and the IOM.
 - Step 5** Remove the uplink ports.
 - Step 6** Erase the configuration on the subordinate fabric interconnect and remove the cluster cables.
 - Step 7** Connect the UCS 6332 Fabric Interconnect to the primary UCS 6248 Fabric Interconnect in the cluster.
 - Step 8** Connect the 4x10 breakout cables on the UCS 6332 Fabric Interconnect to the UCS 2204 or UCS 2208 IOM.
 - Step 9** Join the subordinate fabric interconnect to the cluster.
 - Step 10** Launch a new Cisco UCS Manager GUI window.
 - Step 11** Configure the breakout ports in the subordinate fabric interconnect to operate as 10-Gbps on 40 interfaces.
 - Step 12** Configure the server and the uplink ports. Make sure that Cisco UCS Manager discovers the IOM.
 - Step 13** Once the IOM comes up, **Auto Upgrade** will begin. Wait for the upgrade to complete before proceeding.
 - Step 14** Make sure that the IOM is in the **Operable** state.
 - Step 15** Verify that the backplane ports on the IOM are connected to the Cisco UCS 6332 subordinate fabric interconnect. If all ports are up, then proceed to the next step. If the ports are not up, then click **Acknowledge IO Module**.
 - Step 16** Disable **Configuration Evacuation** in the subordinate fabric interconnect.
 - Step 17** Once HA is ready, change the primary role to the Cisco UCS 6332 Fabric Interconnect cluster lead.
 - Step 18** Repeat steps 2 to 16 to replace the Cisco UCS 6248 Fabric Interconnect with a Cisco UCS 6332 Fabric Interconnect.
-

Migrating IO Modules

The following steps apply when migrating from a Cisco UCS 2204 or UCS 2208 IOM to a Cisco UCS 2304 IOM.



Note If the primary and the subordinate IOMs are different models—Cisco UCS 2204, UCS 2208, or UCS 2304—the overall status of the IOMs is shown as **Peer Comm Problem**. However, the IOMs can still be replaced.

Procedure

-
- Step 1** Remove the configuration on the server ports that are connected to the Cisco UCS 2204 or UCS 2208 IOM in the subordinate fabric interconnect.
 - Step 2** Remove the cables and replace the Cisco UCS 2204 or UCS 2208 IOM with the Cisco UCS 2304 IOM in the chassis.
 - Step 3** Connect the 40-Gbps cables to the UCS 2304 IOM and the UCS 6332 Fabric Interconnect.
 - Step 4** Configure the ports as server ports.
 - Step 5** Wait for **Auto Upgrade** to complete in the IOM.
-

Migrating FEX Modules

The following steps describe how to migrate from a Cisco Nexus 2232PP FEX to a Cisco Nexus 2348UPQ FEX.



Note The Cisco Nexus 2232PP FEX has 10-Gbps uplink ports. The Cisco Nexus 2348UPQ FEX has 40-Gbps ports which are supported only by the Cisco UCS 2304 IOM.

Procedure

-
- Step 1** Decommission the existing Cisco Nexus 2232PP FEX.
 - Step 2** Remove the cables and install the Cisco Nexus 2348UPQ FEX.
 - Step 3** Connect the cables to the Cisco Nexus 2348UPQ FEX.
 - Step 4** Wait for Cisco UCS Manager to complete its **Discovery** and **Auto Upgrade** of the new FEX module.
 - Step 5** Reacknowledge all the servers that are connected through the Cisco Nexus 2348UPQ FEX.
-

Installing and Removing a Fan Module

You can hot swap a fan module (N20-FAN5) without causing an electrical hazard or damage to the system. However, you can only remove one fan module while the system is operating. Removing more than one fan module could cause overheating.



Note When a fan is removed, louvers inside the chassis prevent recirculation of air into the system or loss of cooling. However, you should not leave the chassis for extended periods of time without all fan modules in place.

Installing a Fan Module

Procedure

- Step 1** Hold the fan module with the spring latch at the top of the module.
- Step 2** Push the fan module into the chassis until it seats properly and the spring latch snaps into place.
- Step 3** Listen for the fans if the chassis is powered on. You should immediately hear it operating. If you do not hear it, ensure that the fan module is inserted completely in the chassis and the faceplate is flush with the outside surface of the chassis.
- Step 4** Verify that the LED behavior is as expected. See [LED Locations](#), on page 35 and [Interpreting LEDs](#), on page 36.

Figure 47: Positioning a Fan Module (N20-FAN5) in the Cisco UCS Server Chassis

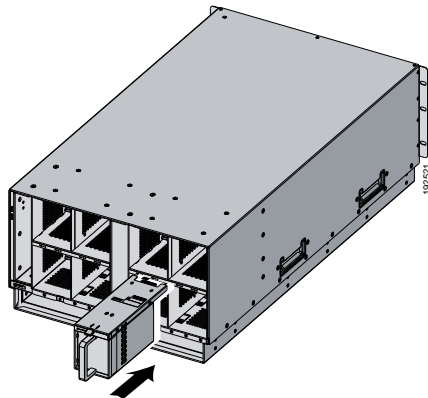

Removing a Fan Module

Procedure

Step 1 Hold the fan module by its handle.

Step 2 Press down on the spring latch at the top of the fan module.

Step 3 Pull the fan module clear of the chassis.

Note The chassis is designed to have all fan modules in place and operating at all times. Do not leave a fan module bay empty for longer than is necessary to replace it with a new fan module.



APPENDIX A

Technical Specifications

This appendix lists the technical specifications for the Cisco UCS 5108 server chassis and includes the following sections:

- [KVM Cable, page 83](#)
- [Chassis Specifications, page 84](#)
- [Environmental Specifications, page 85](#)
- [Specifications for the Cisco UCS 5108 Blade Server Chassis Power Supply Units, page 86](#)
- [Supported AC Power Cords and Plugs, page 89](#)

KVM Cable

The KVM cable (N20-BKVM) provides a connection into a Cisco UCS blade server, providing a DB9 serial connector, a VGA connector for a monitor, and dual USB ports for a keyboard and mouse. With this cable you can create a direct connection to the operating system and the BIOS running on a blade server.

Figure 48: KVM Cable for Blade Servers

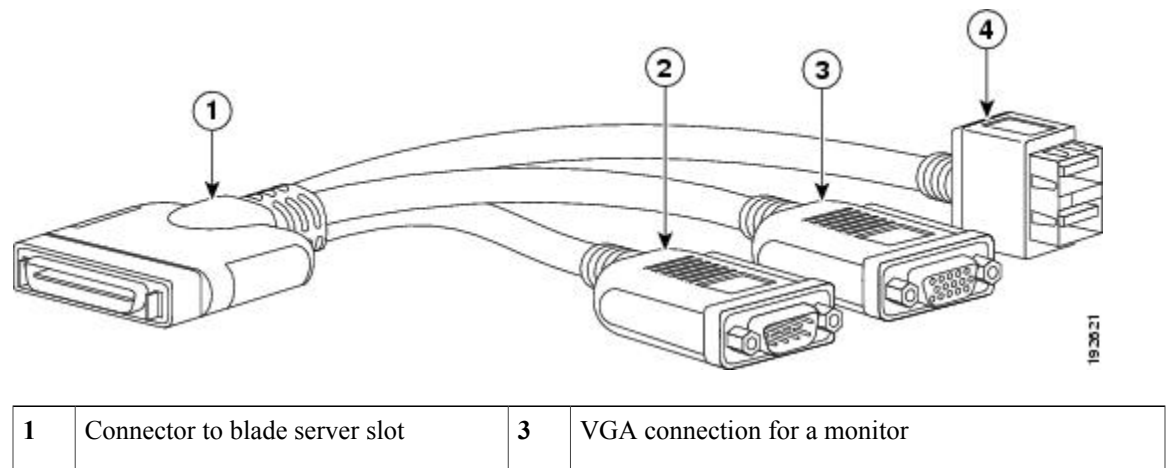

2	DB9 serial connector	4	2-port USB connector for a mouse and keyboard
---	----------------------	---	---

Chassis Specifications

Table 15: Cisco UCS Server Chassis

Description	Specification
Height x Width x Depth	10.5 in (26.7 cm) x 17.5 in (44.5 cm) x 32 in (81.2 cm)
Blade server slots	8
FEX slots	2
Fan module bays	8
Power supply bays	4
Backplane throughput	1.2 Tb aggregate

Table 16: Weight of the Chassis Components

Description	Specification
Empty chassis	90 lbs (40.83 kg)
FEX	2.5 lbs (1.13 kg)
UCS 6324 Fabric Interconnect	2.5 lbs (1.13 kg)
Fan module	1.8 lbs (0.82 kg)
B200 Blade Server	13.5 lbs (6.1 kg) ⁵
B230 Blade Server	18.0 lbs (8.16 kg) ⁵
B250 Blade Server	25 lbs (11.34 kg) ⁵
B440 Blade Server	34.5 lbs (15.65 kg) ⁵
Hard drive	0.8 lbs (0.36 kg)
Fully Populated UCS 5108 Server Chassis	Approximately 255 lbs (115.66 kg), depending on models and options selected

⁵ The system weight listed here is an estimate for a fully configured system and will vary depending on the devices installed.

Environmental Specifications

Table 17: Environmental Specifications for the Chassis

Description	Specification
Temperature, operating within altitude: 0 to 10,000 feet (0 to 3,000 meters)	50 to 95°F (10 to 35°C)
Temperature, non-operating within altitude: 0 to 40,000 feet (0 to 12,000 meters)	-40 to 149°F (-40 to 65°C)
Humidity (RH), noncondensing	Operating: 10-90%, 28°C max. wet bulb Nonoperating: 5-93%, 38°C max wet bulb
Altitude	Operating – 0 to 10000 feet (0 to 3000 meters) Above 10,000 feet, maximum temperature decreases by 1°C per 1000 feet (~300 meters) above 10,000 feet Nonoperating – 40,000 ft (12,000 m)
Sound Pressure Level	83 dBA—at normal operating temperature.

Environmental Conditions and Power Requirement Specifications for Twinax SFP+ Transceivers

Table 18: Environmental Conditions and Power Requirement for the SFP+ Transceiver

Parameter	Symbol	Min.	Max.	Unit
Storage temperature	TS	-40	85	°C
Case temperature	TC	0	50	°C
Module supply voltage	VCCT,R	3.1	3.5	V

Specifications for the Cisco UCS 5108 Blade Server Chassis Power Supply Units

Table 19: AC-input Gold Power Supply (N20-PAC5-2500W) Specifications

Description	Specification
AC-input voltage	Voltage Range 100-120 VAC, 200-240 VAC nominal (range: 90-132 VAC, 180-264 VAC)
AC-input frequency	50 to 60 Hz nominal (range: 47 to 63 Hz)
Maximum AC-input current	12.5 A @ 100 VAC 6.0 A @208 VAC
Maximum input VA	1250 VA at 100 VAC
Maximum output power per power supply	800 W @ 100-120 VAC 1050 W @ 200-240 VAC
Maximum inrush current	15 A (sub cycle duration)
Maximum hold up time	12 ms @ 770 W
Power supply output voltage	12 VDC
Power supply standby voltage	12 VDC
Efficiency Rating	Climate Savers Platinum Efficiency (80Plus Platinum Certified)
Form Factor	RSP2 (C-Series 1U and C3x60 Storage Server)
Input connector	IEC320 C14

Table 20: AC-input Platinum Power Supply (UCSB-PSU-2500ACPL) Specifications

Description	Specification
Minimum Software requirement	UCS Software Release 2.0(2)
AC-input voltage	200 to 240 VAC nominal (Range: 180 to 264 VAC)
AC-input frequency	50 and 60 Hz nominal (Range: 47 to 63 Hz)
AC-input current	< 16 Amps @ 200 VAC

Description	Specification
Maximum Input VA	2790 VA @ 200 VAC
Maximum output power per power supply	2500 W (up to four power supplies)
Maximum inrush current	35 A (sub cycle duration)
Maximum Heat Output	8530 BTU
Maximum hold up time	12 ms @ 2500 W
Power supply output voltage	12 VDC @ 208 A
Power supply standby voltage	3.3 VDC @ 5A
Efficiency Rating	Climate Savers Platinum
Efficiency (80 Plus Platinum Certified)	20% 50% 100% 90% 94% 91%
Input connector	IEC320 C20

Table 21: DC-Input Power Supply (UCSB-PSU-2500DC48) Specifications

Item	Specification
Minimum software requirement	Cisco UCS Software Release 2.0(1) Capability Catalog Version 42
DC-input voltage	-48 to -60 VDC
Maximum output power	2500 W
Maximum inrush current	35 A
Current draw at min voltage	62 A
Current draw at max voltage	50 A
Maximum input VA	2880
Efficiency	10% 20% 50% 100% 88.73% 91.68% 92.19% 90.51%

Item	Specification
DC input terminal block	Accepts Panduit LCD4-14AF-L or equivalent barrel-type lug terminals with 90-degree angle, two-hole tongue, which accommodates 1/0 AWG size copper wire. The connector tongue width is 0.82 in, the stud hole spacing is 5/8 in, and the hole size is 1/4 in.
Output holdup time	8 ms

Table 22: HVDC-Input Platinum Power Supply (UCSB-PSU-2500HVDC) Specifications

Item	Specification
DC-input voltage	200 to 380 VDC nominal (Range: 180 to 400 VDC)
Maximum DC-input current	15.5 Amps @ 200 VDC
Maximum output power	2500 W
Maximum inrush current	35 A
Efficiency rating	Climate Savers Platinum
Efficiency (80 Plus Platinum Certified)	10% 20% 50% 100% 93.5% 94.9% 95% 93%
Power supply output voltage	12 VDC
Maximum holdup time	12 ms 2500 W
Input connector	IEC320 C20

Table 23: AC-input Dual Voltage Platinum Power Supply (UCSB-PSU-2500ACDV) Specifications

Description	Specification
AC-input voltage	200 to 240 VAC nominal (Range: 180 to 264 VAC) 100 to 120 VAC nominal (Range: 90 to 127 VAC) supported only with the UCS 6324 Fabric Interconnect
AC-input frequency	50 and 60 Hz nominal (Range: 47 to 63 Hz)
AC-input current	< 15 Amps @ 200 VAC
Maximum Input VA	2790 VA @ 200 VAC

Description	Specification
Maximum output power per power supply	2500 W @ 200 to 240 VAC 1300 W @ 100 to 120 VAC
Maximum inrush current	35 A (sub cycle duration)
Maximum Heat Output	8530 BTU
Maximum hold up time	12 ms @ 2500 W
Power supply output voltage	12 VDC @ 208 A
Power supply standby voltage	3.3 VDC @ 5A
Efficiency Rating	Climate Savers Platinum
Efficiency (80 Plus Platinum Certified)	10% 20% 50% 100% 93.5% 94.9 % 95% 93%
Input connector	IEC320 C20

DC wiring must meet your local codes and regulations, we recommend using a licensed local electrician to install the DC wiring needed.

To determine the number of power supply units needed for the blade server, remember that each single slot server is budgeted a max 550 W and each full width server is budgeted a max 1100 W. For a more detailed estimate, contact Cisco Sales.

Supported AC Power Cords and Plugs

The AC power connectors on the blade server chassis PDU use an IEC 320 C20 socket. Each chassis power supply has a separate power cord. The power cord that you use to connect the blade server power supply units to an AC power source will have an IEC 320 C19 plug on one end and on the other end one that conforms to the AC power outlet specifications for your country. See the following table to determine which cord to order for your blade server chassis power supply units. When you determine which power cord you need to order, you can verify that its plugs conform to the power outlets for your facility by clicking on its reference link.

The jumper power cords, for use in racks, are available as an optional alternative to the standard power cords. The optional jumper power cords have an IEC C19 connector (such as a Cisco RP Series PDU) on the end that plugs into the chassis' PDU and an IEC C20 connector on the end that plugs into an IEC C19 outlet receptacle. For more information, contact your Cisco Systems representative.



Note

Only the regular power cords or jumper power cords provided with the chassis are supported.

Australia and New Zealand

Power Cord Part Number—CAB-AC-16A-AUS

Cord Set Rating—16A, 250 VAC

Figure 49: CAB-AC-16A-AUS Power Cord for the Cisco UCS 5108 Blade Server Chassis

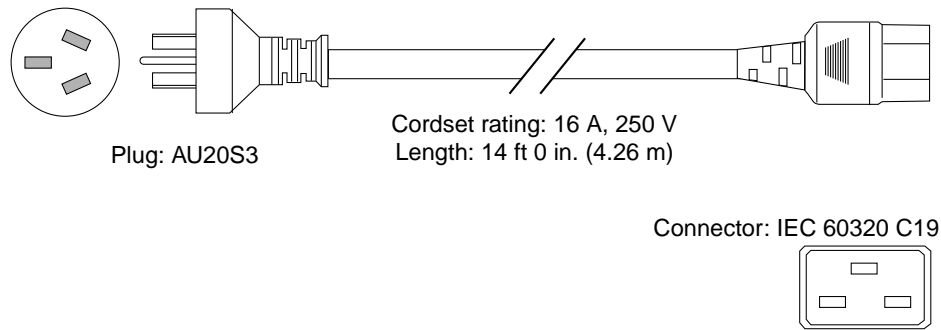

140586

Continental Europe

Power Cord Part Number—CAB-AC-2500W-EU

Cord Set Rating—16A, 250 VAC

Figure 50: CAB-AC-2500W-EU Power Cord for the UCS 5108 Blade Server Chassis

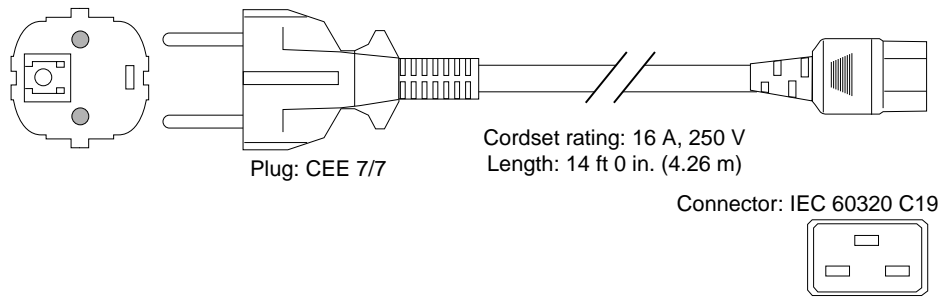

113360

International

Power Cord Part Number—CAB-AC-2500W-INT

Cord Set Rating—16A, 250 VAC

Figure 51: CAB-AC-2500W-INT Power Cord for the UCS 5108 Blade Server Chassis

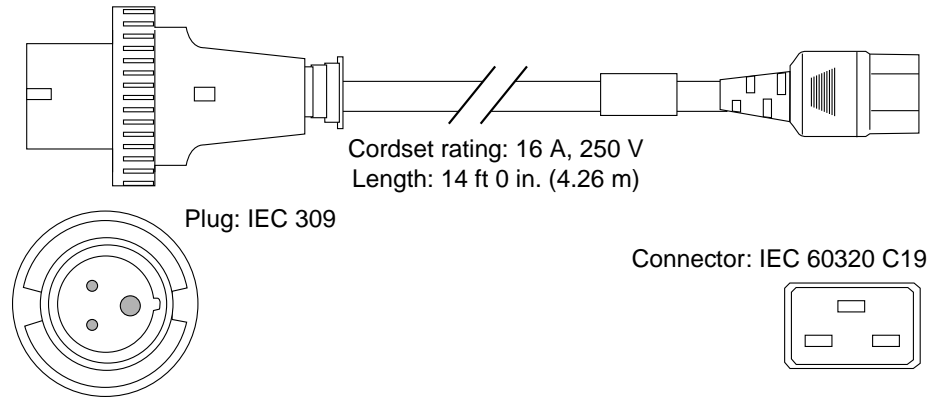

113361

Israel

Power Cord Part Number—CAB-AC-2500W-ISRL

Cord Set Rating—16A, 250 VAC

Figure 52: CAB-AC-2500W-ISRL Power Cord for the UCS 5108 Blade Server Chassis

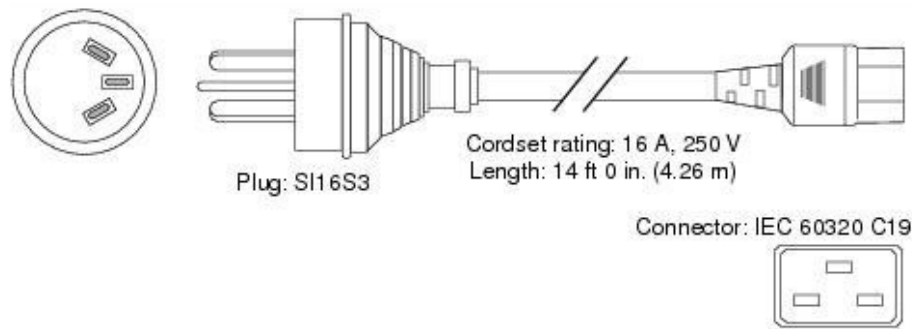

130113

Japan and North America

Non-Locking 200 to 240 VAC operation

Power Cord Part Number—CAB-AC-2500W-US1

Cord Set Rating—16A, 250 VAC

Figure 53: CAB-AC-2500W-US1 Power Cord for the UCS 5108 Blade Server Chassis

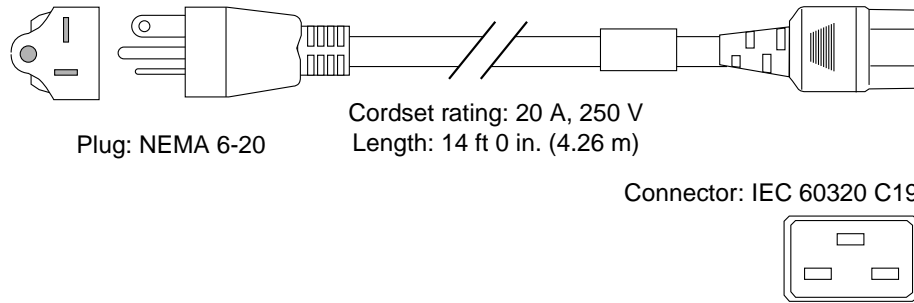

113362

Locking 200 to 240 VAC Operation

Power Cord Part Number—CAB-AC-C6K-TWLK

Cord Set Rating—16A, 250 VAC

Figure 54: CAB-AC-C6K-TWLK Power Cord for the UCS 5108 Blade Server Chassis

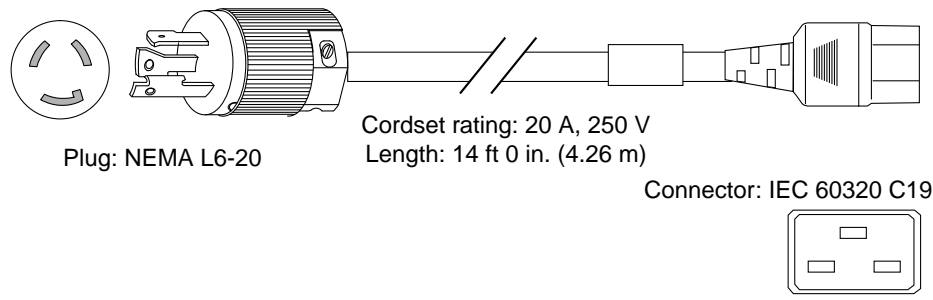

113363

Peoples Republic of China

Power Cord Part Number—CAB-AC-16A-CH

Cord Set Rating—16A, 250 VAC

Figure 55: CAB-AC-16A-CH Power Cord for the Cisco UCS 5108 Blade Server Chassis

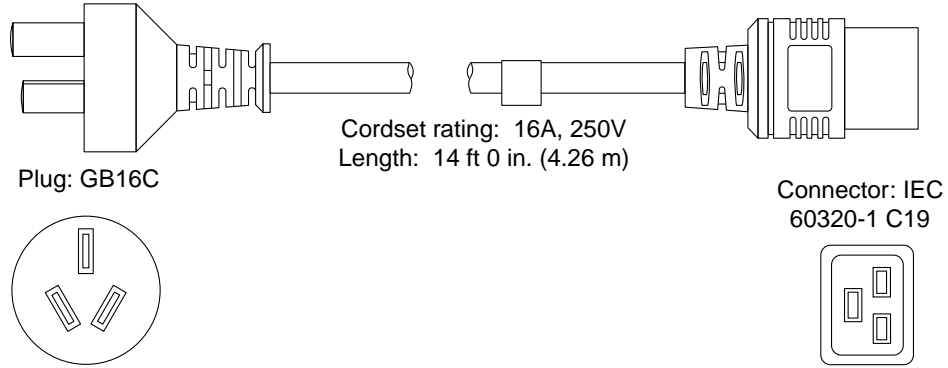

126792

Switzerland

Power Cord Part Number—CAB-ACS-16

Cord Set Rating—16A, 250 VAC

Figure 56: CAB-ACS-16 Power Cord for the UCS 5108 Blade Server Chassis

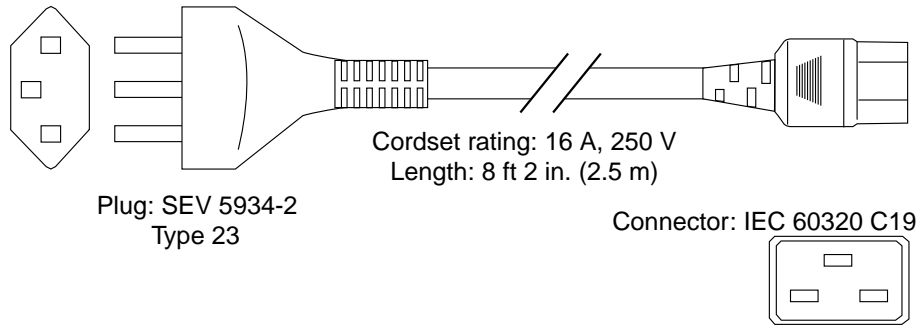

192844

Power Distribution Unit (PDU)

Power Cord Part Number—CAB-C19-CBN

Cord Set Rating—Not applicable

Figure 57: CAB-C19-CBN Power Cord for the UCS 5108 Blade Server Chassis

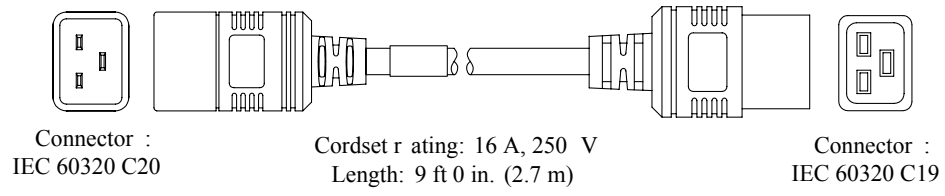

140587



Site Planning and Maintenance Records



Note

For information about how to query the chassis for configuration information, see the *Cisco UCS Configuration Guide*.

This appendix includes the following records to use when installing the Cisco UCS server chassis:

- [Site Preparation Checklist, page 95](#)
- [Contact and Site Information, page 97](#)
- [Chassis and Module Information, page 97](#)
- [FEX Port Connection Record, page 99](#)
- [UCS 6324 Fabric Interconnect Port Connection Record, page 100](#)

Site Preparation Checklist

Planning the location and layout of your equipment is essential for successful network operation, ventilation, and accessibility. Consider heat dissipation when sizing the air-conditioning requirements for an installation.

Table 24: Site Planning Checklist

Task No.	Planning Activity	Verified By	Time	Date
1	Space evaluation: <ul style="list-style-type: none"> • Space and layout • Floor covering • Impact and vibration • Lighting • Maintenance access 			

Task No.	Planning Activity	Verified By	Time	Date
2	Environmental evaluation: <ul style="list-style-type: none"> • Ambient temperature • Humidity • Altitude • Atmospheric contamination • Air flow 			
3	Power evaluation: <ul style="list-style-type: none"> • Input power type • Power receptacles⁶ • Receptacle proximity to the equipment • Dedicated circuit for power supply • Dedicated (separate) circuits for redundant power supplies • UPS⁷ for power failures 			
4	Grounding evaluation: <ul style="list-style-type: none"> • Circuit breaker size • CO ground (AC- powered systems) 			
5	Cable and interface equipment evaluation: <ul style="list-style-type: none"> • Cable type • Connector type • Cable distance limitations • Interface equipment (transceivers) 			
6	EMI ⁸ evaluation: <ul style="list-style-type: none"> • Distance limitations for signaling • Site wiring • RFI⁹ levels 			

⁶ Verify that the power supply installed in the chassis has a dedicated AC source circuit.

⁷ UPS: uninterruptable power supply.

- ⁸ EMI: electromagnetic interference.
⁹ RFI: radio frequency interference.

Contact and Site Information

Use the following worksheet to record contact and site information.

Table 25: Contact and Site Information

Contact person	
Contact phone	
Contact e-mail	
Building/site name	
Data center location	
Floor location	
Address (line 1)	
Address (line 2)	
City	
State	
Zip code	
Country	

Chassis and Module Information

Use the following worksheets to record information about the server chassis and the modules it contains.

Contract Number _____

Chassis Serial Number _____

Product Number _____

Table 26: Device Information

Device	Serial Number	Notes
Blade Server-1		

Device	Serial Number	Notes
Blade Server-2		
Blade Server-3		
Blade Server-4		
Blade Server-5		
Blade Server-6		
Blade Server-7		
Blade Server-8		
I/O Module-1		
I/O Module-2		

**Note**

The serial numbers of all server chassis modules can be obtained using Cisco UCS Manager.

FEX Port Connection Record

Table 27: Chassis FEX to Fabric Interconnect Port Connection Record

FEX		Connected to			
Number	Port	Fabric Interconnect A or B	Slot	Port	Connection notes
1	1				
	2				
	3				
	4				
	5				
	6				
	7				
	8				
2	1				
	2				
	3				
	4				
	5				
	6				
	7				
	8				

UCS 6324 Fabric Interconnect Port Connection Record

Table 28: Port Connection Record

Fabric Interconnect		Connected to		
Number	Port	Slot	Port	Connection notes
1	1			
	2			
	3			
	4			
	5			
	6			
	7			
	8			
2	1			
	2			
	3			
	4			
	5			
	6			
	7			
	8			