



X11SSH-GF-1585  
X11SSH-GF-1585L  
X11SSH-GTF-1585  
X11SSH-GTF-1585L

USER'S MANUAL

Revision 1.0b

The information in this User's Manual has been carefully reviewed and is believed to be accurate. The vendor assumes no responsibility for any inaccuracies that may be contained in this document, and makes no commitment to update or to keep current the information in this manual, or to notify any person or organization of the updates. **Please Note: For the most up-to-date version of this manual, please see our website at [www.supermicro.com](http://www.supermicro.com).**

Super Micro Computer, Inc. ("Supermicro") reserves the right to make changes to the product described in this manual at any time and without notice. This product, including software and documentation, is the property of Supermicro and/or its licensors, and is supplied only under a license. Any use or reproduction of this product is not allowed, except as expressly permitted by the terms of said license.

IN NO EVENT WILL Super Micro Computer, Inc. BE LIABLE FOR DIRECT, INDIRECT, SPECIAL, INCIDENTAL, SPECULATIVE OR CONSEQUENTIAL DAMAGES ARISING FROM THE USE OR INABILITY TO USE THIS PRODUCT OR DOCUMENTATION, EVEN IF ADVISED OF THE POSSIBILITY OF SUCH DAMAGES. IN PARTICULAR, SUPER MICRO COMPUTER, INC. SHALL NOT HAVE LIABILITY FOR ANY HARDWARE, SOFTWARE, OR DATA STORED OR USED WITH THE PRODUCT, INCLUDING THE COSTS OF REPAIRING, REPLACING, INTEGRATING, INSTALLING OR RECOVERING SUCH HARDWARE, SOFTWARE, OR DATA.

Any disputes arising between manufacturer and customer shall be governed by the laws of Santa Clara County in the State of California, USA. The State of California, County of Santa Clara shall be the exclusive venue for the resolution of any such disputes. Supermicro's total liability for all claims will not exceed the price paid for the hardware product.

FCC Statement: This equipment has been tested and found to comply with the limits for a Class B digital device pursuant to Part 15 of the FCC Rules. These limits are designed to provide reasonable protection against harmful interference when the equipment is operated in a commercial environment. This equipment generates, uses, and can radiate radio frequency energy and, if not installed and used in accordance with the manufacturer's instruction manual, may cause harmful interference with radio communications. Operation of this equipment in a residential area is likely to cause harmful interference, in which case you will be required to correct the interference at your own expense.

California Best Management Practices Regulations for Perchlorate Materials: This Perchlorate warning applies only to products containing CR (Manganese Dioxide) Lithium coin cells. "Perchlorate Material-special handling may apply. See [www.dtsc.ca.gov/hazardouswaste/perchlorate](http://www.dtsc.ca.gov/hazardouswaste/perchlorate)".



WARNING: This product can expose you to chemicals including lead, known to the State of California to cause cancer and birth defects or other reproductive harm. For more information, go to [www.P65Warnings.ca.gov](http://www.P65Warnings.ca.gov).

The products sold by Supermicro are not intended for and will not be used in life support systems, medical equipment, nuclear facilities or systems, aircraft, aircraft devices, aircraft/emergency communication devices or other critical systems whose failure to perform be reasonably expected to result in significant injury or loss of life or catastrophic property damage. Accordingly, Supermicro disclaims any and all liability, and should buyer use or sell such products for use in such ultra-hazardous applications, it does so entirely at its own risk. Furthermore, buyer agrees to fully indemnify, defend and hold Supermicro harmless for and against any and all claims, demands, actions, litigation, and proceedings of any kind arising out of or related to such ultra-hazardous use or sale.

Manual Revision 1.0b

Release Date: August 30, 2018

Unless you request and receive written permission from Super Micro Computer, Inc., you may not copy any part of this document. Information in this document is subject to change without notice. Other products and companies referred to herein are trademarks or registered trademarks of their respective companies or mark holders.

Copyright © 2018 by Super Micro Computer, Inc.  
All rights reserved.

**Printed in the United States of America**

# Preface

## About This Manual

This manual is written for system integrators, IT technicians and knowledgeable end users. It provides information for the installation and use of the X11SSH-GF/-GTF (-1585/-1585L) motherboard.

## About This Motherboard

The X11SSH-GF/-GTF (-1585/-1585L) motherboard supports the Intel® Xeon® E3-1500 v5 (E3-1585 v5/65W; E3-1585L v5/45W) series for advanced graphic performance and high-capacity media processing. Featuring the Intel® C236 chipset, the X11SSH-GF/-GTF (-1585/-1585L) motherboard provides up to 64GB of DDR4 at 2400MHz with ECC support. Enhanced with Intel's Trusted Execution Technology, the motherboard additionally offers technologies such as Virtualization for Directed I/O, vPro, Smart Response, and Rapid Storage. The X11SSH-GF/-GTF (-1585/-1585L) includes PCI Express 3.0 slots with NVMe support, SATA 3.0 ports, and a combination of USB 3.0 and USB 2.0 ports. The X11SSH-GF/-GTF (-1585/-1585L) also comes with a dedicated LAN port, which is supported by the ASpeed AT2400 Baseboard Management Controller.

Please note that this motherboard is intended to be installed and serviced by professional technicians only. For processor/memory updates, please refer to our website at <http://www.supermicro.com/products/>.

## Conventions Used in the Manual

Special attention should be given to the following symbols for proper installation and to prevent damage done to the components or injury to yourself:



**Warning!** Indicates important information given to prevent equipment/property damage or personal injury.



**Warning!** Indicates high voltage may be encountered when performing a procedure.



**Important:** Important information given to ensure proper system installation or to relay safety precautions.



**Note:** Additional Information given to differentiate various models or provides information for correct system setup.

## Contacting Supermicro

### Headquarters

Address: Super Micro Computer, Inc.  
980 Rock Ave.  
San Jose, CA 95131 U.S.A.

Tel: +1 (408) 503-8000

Fax: +1 (408) 503-8008

Email: [marketing@supermicro.com](mailto:marketing@supermicro.com) (General Information)  
[support@supermicro.com](mailto:support@supermicro.com) (Technical Support)

Website: [www.supermicro.com](http://www.supermicro.com)

### Europe

Address: Super Micro Computer B.V.  
Het Sterrenbeeld 28, 5215 ML  
's-Hertogenbosch, The Netherlands

Tel: +31 (0) 73-6400390

Fax: +31 (0) 73-6416525

Email: [sales@supermicro.nl](mailto:sales@supermicro.nl) (General Information)  
[support@supermicro.nl](mailto:support@supermicro.nl) (Technical Support)  
[rma@supermicro.nl](mailto:rma@supermicro.nl) (Customer Support)

Website: [www.supermicro.nl](http://www.supermicro.nl)

### Asia-Pacific

Address: Super Micro Computer, Inc.  
3F, No. 150, Jian 1st Rd.  
Zhonghe Dist., New Taipei City 235  
Taiwan (R.O.C)

Tel: +886-(2) 8226-3990

Fax: +886-(2) 8226-3992

Email: [support@supermicro.com.tw](mailto:support@supermicro.com.tw)

Website: [www.supermicro.com.tw](http://www.supermicro.com.tw)

# Table of Contents

## **Chapter 1 Introduction**

1.1 Checklist .....	8
Quick Reference .....	11
Quick Reference Table .....	12
Motherboard Features .....	14
1.2 Processor and Chipset Overview .....	18
1.3 Special Features .....	18
Recovery from AC Power Loss .....	18
1.4 System Health Monitoring .....	19
Onboard Voltage Monitors .....	19
Fan Status Monitor with Firmware Control .....	19
Environmental Temperature Control .....	19
System Resource Alert .....	19
1.5 ACPI Features .....	20
1.6 Power Supply .....	20
1.7 Super I/O .....	20
1.8 Advanced Power Management .....	21
Intel® Intelligent Power Node Manager (IPNM) .....	21
Management Engine (ME) .....	21

## **Chapter 2 Installation**

2.1 Static-Sensitive Devices .....	22
Precautions .....	22
Unpacking .....	22
2.2 Motherboard Installation .....	23
Tools Needed .....	23
Location of Mounting Holes .....	23
Installing the Motherboard .....	24
2.3 Memory Support and Installation .....	25
Memory Support .....	25
SO-DIMM Module Population Sequence .....	25
SO-DIMM Installation .....	26

---

SO-DIMM Removal .....	26
2.4 Rear I/O Ports .....	27
2.5 Front Control Panel .....	32
2.6 Connectors .....	36
Power Connections .....	36
Headers .....	38
2.7 Jumper Settings .....	45
How Jumpers Work .....	45
2.8 LED Indicators .....	52
<b>Chapter 3 Troubleshooting</b>	
3.1 Troubleshooting Procedures .....	54
Before Power On .....	54
No Power .....	54
No Video .....	55
System Boot Failure .....	55
Memory Errors .....	55
Losing the System's Setup Configuration .....	56
When the System Becomes Unstable .....	56
3.2 Technical Support Procedures .....	58
3.3 Frequently Asked Questions .....	59
3.4 Battery Removal and Installation .....	60
Battery Removal .....	60
Proper Battery Disposal .....	60
Battery Installation .....	60
3.5 Returning Merchandise for Service .....	61
<b>Chapter 4 BIOS</b>	
4.1 Introduction .....	62
Starting the Setup Utility .....	62
How To Change the Configuration Data .....	63
4.2 Main Setup .....	63
4.3 Advanced Setup Configurations .....	65
4.4 Event Logs .....	89
4.5 IPMI .....	91

---

4.6 Security.....	93
4.7 Boot Settings.....	95
4.8 Save & Exit.....	97

**Appendix A BIOS Codes**

**Appendix B Software Installation**

B.1 Installing Software Programs .....	101
B.2 SuperDoctor® 5.....	102

**Appendix C Standardized Warning Statements**

Battery Handling.....	103
Product Disposal .....	105

**Appendix D UEFI BIOS Recovery**

# Chapter 1

## Introduction

Congratulations on purchasing your computer motherboard from an industry leader. Supermicro motherboards are designed to provide you with the highest standards in quality and performance.

In addition to the motherboard, the following items are included in your shipping package. If anything listed is damaged or missing, please contact your retailer.

### 1.1 Checklist

Main Parts List		
Description	Part Number	Quantity
Supermicro Motherboard	X11SSH-GF/-GTF	1
I/O Shield	MCP-260-00042-0N	1
57.5CM SATA Flat S-S PBF	CBL-0044L	6
X11SSH-GF/-GTF Quick Reference Guide	MNL-1924-QRG	1

### Important Links

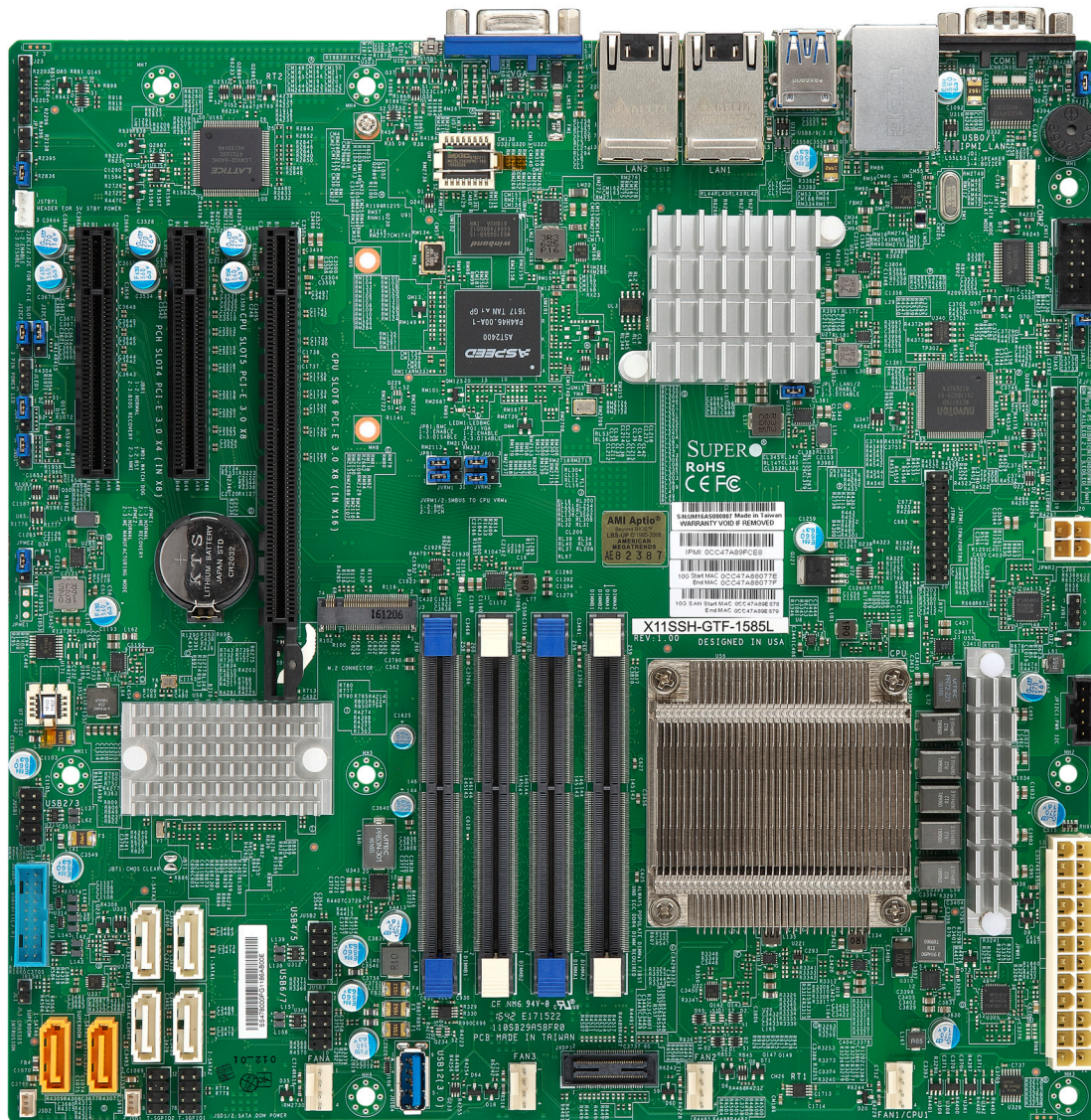
For your system to work properly, please follow the links below to download all necessary drivers/utilities and the user's manual for your server.

- Supermicro product manuals: <http://www.supermicro.com/support/manuals/>
- Product drivers and utilities: <https://www.supermicro.com/wftp/driver/>
- Product safety info: [http://www.supermicro.com/about/policies/safety\\_information.cfm](http://www.supermicro.com/about/policies/safety_information.cfm)
- If you have any questions, please contact our support team at: [support@supermicro.com](mailto:support@supermicro.com)

This manual may be periodically updated without notice. Please check the Supermicro website for possible updates to the manual revision level.

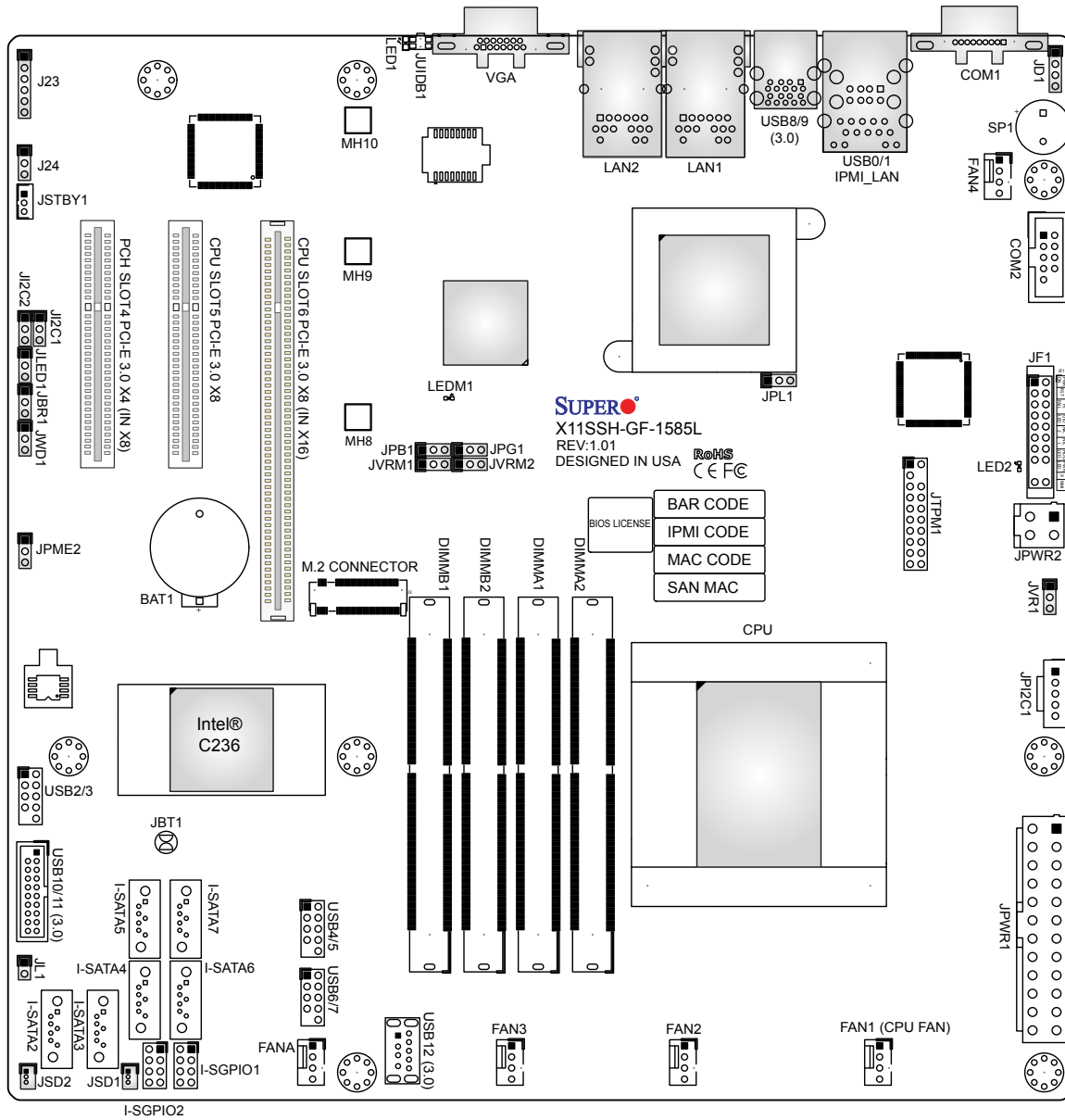



Figure 1-1. X11SSH-GF/-GTF (-1585/1585L) Motherboard Image



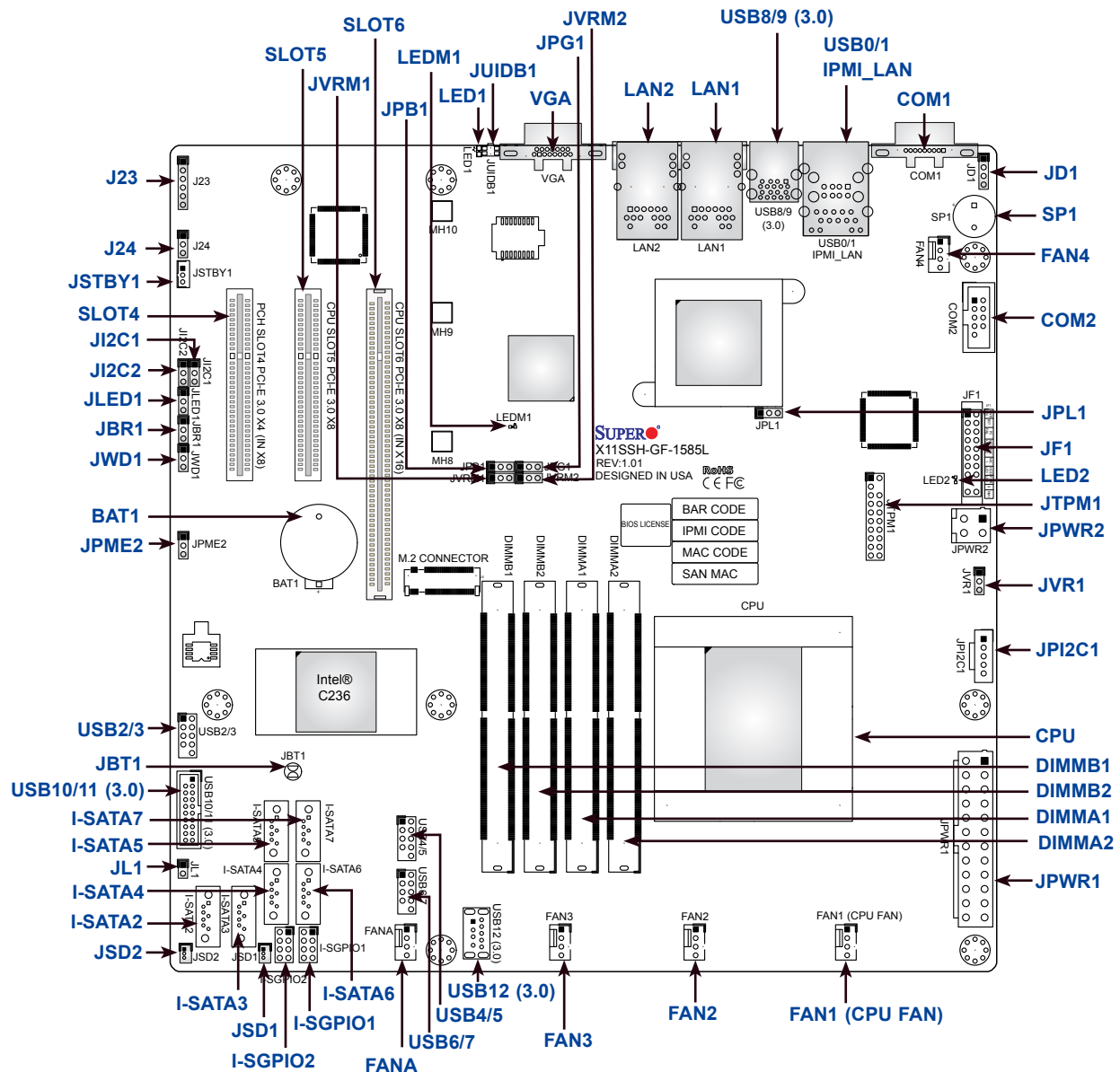
**Note:** All graphics shown in this manual were based upon the latest PCB revision available at the time of publishing of the manual. The motherboard you received may or may not look exactly the same as the graphics shown in this manual.

**Figure 1-2. X11SSH-GF/-GTF (-1585/1585L) Motherboard Layout**  
(not drawn to scale)



 **Note:** Components not documented are for internal testing only.

## Quick Reference



## Notes:

- See Chapter 2 for detailed information on jumpers, I/O ports, and JF1 front panel connections.
- "■" indicates the location of Pin 1.
- Jumpers/LED indicators not indicated are used for testing only.
- Use only the correct type of onboard CMOS battery as specified by the manufacturer. Do not install the onboard battery upside down to avoid possible explosion.

## Quick Reference Table

Jumper	Description	Default Setting
JBR1	BIOS Recovery	Pins 1-2 (Normal)
JBT1	CMOS Clear	Open (Normal)
JI <sup>2</sup> C1/JI <sup>2</sup> C2	SMB to PCI-E Slots Enable/Disable	Pins 2-3 (Disabled)
JLED1	Power LED Enable/Disable	Pins 1-2 (Enabled)
JPB1	BMC Enable/Disable	Pins 1-2 (Enabled)
JPG1	VGA Enable/Disable	Pins 1-2 (Enabled)
JPL1	LAN1/2 Enable/Disable	Pins 1-2 (Enabled)
JPME2	ME Manufacturing Mode	Pins 1-2 (Normal)
JVRM1	VRM SMB Clock (to BMC or PCH)	Pins 1-2 (BMC, Normal)
JVRM2	VRM SMB Data (to BMC or PCH)	Pins 1-2 (BMC, Normal)
JWD1	Watch Dog Timer	Pins 1-2 (Reset)

LED	Description	Status
LED1	Unit Identifier LED	Blue: Unit Identified
LED2	Power LED	Solid Green: Power On
LEDM1	BMC Heartbeat LED	Blinking Green: BMC Normal

Connector	Description
BAT1	Onboard CMOS Battery
COM1/COM2	Serial COM Ports
FAN1 ~ FAN4, FANA	System/CPU Fan Headers (FAN1: CPU Fan)
IPMI_LAN	Dedicated IPMI LAN Port
I-SATA2 ~ I-SATA7	Intel® PCH SATA 3.0 Ports
I-SGPIO1/I-SGPIO2	Serial Link General Purpose I/O Headers
JD1	Power LED/Speaker Header (Pins 1-3: Power LED, Pins 1-4: Speaker)
JF1	Front Control Panel Header
JL1	Chassis Intrusion Header
JPI <sup>2</sup> C1	Power Supply SMBus I <sup>2</sup> C Header
JPWR1	24-pin ATX Power Connector
JPWR2	4-pin CPU Power Connector
JSD1/JSD2	SATA DOM Power Connectors
JSTBY1	Standby Power Header
JTPM1	Trusted Platform Module/Port 80 Connector
JUIDB1	Unit Identifier Switch
JVR1	SMB Programmable Header (for debugging only)
LAN1 ~ LAN2	LAN (RJ45) Ports
M.2	M.2 Slot
SLOT4	PCI-Express 3.0 X4 (IN X8) Slot supported by Intel® PCH

<b>Connector</b>	<b>Description</b>
SLOT5	PCI-Express 3.0 X8 Slot supported by the CPU
SLOT6	PCI-Express 3.0 X8 (IN X16) Slot supported by the CPU
SP1	Internal Speaker/Buzzer
USB0/1	Back Panel Universal Serial Bus (USB) 2.0 Port
USB2/3, 4/5, 6/7	USB 2.0 Header
USB8/9	Back Panel Universal Serial Bus (USB) 3.0 Port
USB10/11	USB 3.0 Header
USB12	USB 3.0 Type A Header
VGA	Back Panel VGA Port

## Motherboard Features

<b>Motherboard Features</b>	
<b>CPU</b>	
<ul style="list-style-type: none"> <li>Single Intel® Xeon® E3-1500 v5 processor in a BGA socket</li> </ul>	
<b>Memory</b>	
<ul style="list-style-type: none"> <li>Integrated memory controller supports up to 64GB of unbuffered DDR4 ECC SO-DIMM 2400MHz memory</li> </ul>	
<b>DIMM Size</b>	
<ul style="list-style-type: none"> <li>Up to a total of 64GB at 1.2V in four (4) DIMM slots</li> </ul>	
<b>Chipset</b>	
<ul style="list-style-type: none"> <li>Intel® PCH C236</li> </ul>	
<b>Expansion Slots</b>	
<ul style="list-style-type: none"> <li>One (1) PCI Express 3.0 X4 (IN X8) slot (PCH Slot 4)</li> <li>One (1) PCI Express 3.0 X8 Slot (CPU slot 5)</li> <li>One (1) PCI Express 3.0 X8 (IN X16) slot (CPU Slot 6)</li> <li>One (1) M.2 PCI Express 3.0 x4 connector</li> </ul>	
<b>Network</b>	
<ul style="list-style-type: none"> <li>Dual Gbe LAN port (Intel® I350-BT2, X11SSH-GF (-1585/-1585L))</li> <li>Dual 10Gbe LAN port (Intel® X550-BT2, X11SSH-GTF (-1585/-1585L))</li> <li>One (1) dedicated IPMI LAN located on the rear I/O panel</li> </ul>	
<b>Baseboard Management Controller (BMC)</b>	
<ul style="list-style-type: none"> <li>ASpeed 2400 Baseboard Controller (BMC) supports IPMI 2.0</li> </ul>	
<b>Graphics</b>	
<ul style="list-style-type: none"> <li>Graphics controller via ASpeed 2400 BMC</li> </ul>	
<b>I/O Devices</b>	
<ul style="list-style-type: none"> <li>COM Port</li> <li>SATA Ports               <ul style="list-style-type: none"> <li>RAID (PCH)</li> </ul> </li> <li>Video (VGA) Port</li> </ul>	<ul style="list-style-type: none"> <li>Two (2) COM ports with one (1) in the rear I/O panel and one (1) header</li> <li>Six (6) SATA 3.0 ports supported by Intel® PCH (I-SATA2-7)</li> <li>RAID 0, 1, 5, and 10</li> <li>One (1) VGA connection on the rear I/O panel</li> </ul>
<b>Peripheral Devices</b>	
<ul style="list-style-type: none"> <li>Two (2) USB 2.0 ports on the rear I/O panel (USB0/1)</li> <li>Two (2) USB 3.0 ports on the rear I/O panel (USB8/9)</li> <li>Three (3) USB 2.0 internal headers (USB2/3, USB 4/5, USB6/7)</li> <li>One (1) USB 3.0 internal header (USB10/11)</li> <li>One (1) Type A USB 3.0 header for front access (USB12)</li> </ul>	



**Note:** The table above is continued on the next page.

<b>Motherboard Features</b>
<b>BIOS</b>
<ul style="list-style-type: none"> <li>• 128Mb SPI AMI BIOS® SM Flash UEFI BIOS</li> <li>• ACPI 3.0 or later, SMBIOS 2.7 or later, PCI F/W 3.0, BIOS rescue hot-key, SPI dual/quad speed support</li> </ul>
<b>Power Management</b>
<ul style="list-style-type: none"> <li>• ACPI power management (S5)</li> <li>• Power button override mechanism</li> <li>• Wake-On-LAN</li> <li>• Power-on mode for AC power recovery</li> </ul>
<b>System Health Monitoring</b>
<ul style="list-style-type: none"> <li>• Onboard voltage monitoring for +1.8V, +3.3V, 3.3V Standby, +5V, +5V Standby, +/-12V, VBAT, HT, Memory, PCH Temp., System Temp., Memory Temp.</li> <li>• CPU switching phase voltage regulator</li> <li>• CPU thermal trip support</li> <li>• PECI</li> </ul>
<b>Fan Control</b>
<ul style="list-style-type: none"> <li>• 4-pin fan headers</li> <li>• Fan speed control</li> </ul>
<b>System Management</b>
<ul style="list-style-type: none"> <li>• IPMI (Intelligent Platform Management Interface) support</li> <li>• System resource alert via SuperDoctor® 5</li> <li>• Chassis intrusion detection</li> <li>• Watch Dog, NMI (Non-maskable interrupt), RoHS (Restriction of Hazardous Substance Directive)</li> <li>• SPM (Supermicro Power Management), SUM (Supermicro Update Manager) with In-Band and Out-of-Band channels</li> </ul>
<b>LED Indicators</b>
<ul style="list-style-type: none"> <li>• CPU/system overheat</li> <li>• Power suspend-state</li> <li>• Fan failure</li> <li>• UID/remote UID</li> <li>• HDD activity</li> <li>• LAN activity</li> </ul>
<b>Dimensions</b>
<ul style="list-style-type: none"> <li>• 9.6" (L) x 9.6" (W) (243.84 mm x 243.84 mm)</li> </ul>



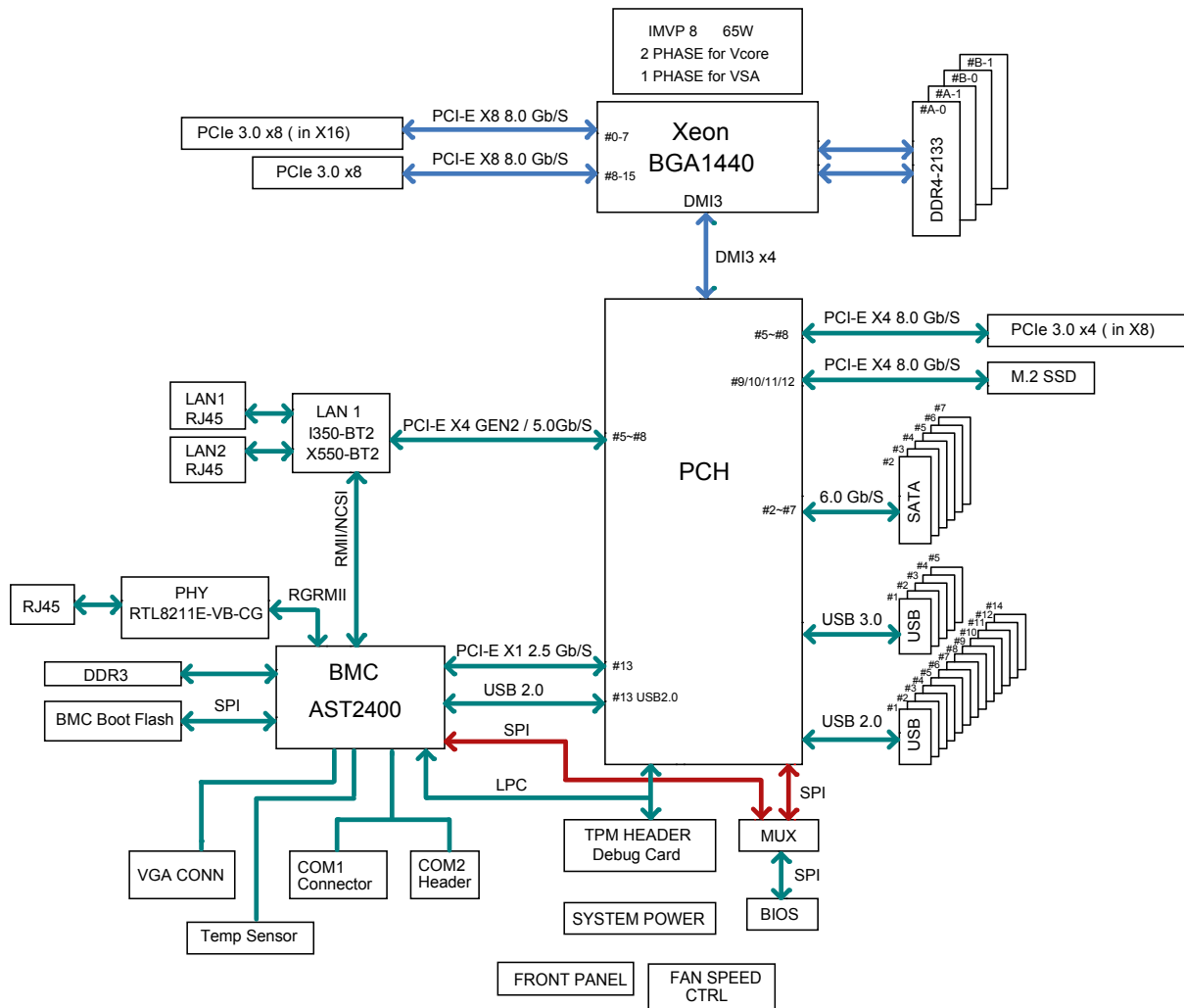
**Note 1:** The CPU maximum thermal design power (TDP) is subject to chassis and heatsink cooling restrictions. For proper thermal management, please check the chassis and heatsink specifications for proper CPU TDP sizing.


**Note 2:** For IPMI configuration instructions, please refer to the Embedded IPMI Configuration User's Guide available at <http://www.supermicro.com/support/manuals/>.

**Note 3:** It is strongly recommended that you change BMC log-in information upon initial system power-on. The manufacture default username is ADMIN and the password is ADMIN. For proper BMC configuration, please refer to [http://www.supermicro.com/products/info/files/IPMI/Best\\_Practices\\_BMC\\_Security.pdf](http://www.supermicro.com/products/info/files/IPMI/Best_Practices_BMC_Security.pdf)



**Figure 1-3.**  
**System Block Diagram**



 **Note:** This is a general block diagram and may not exactly represent the features on your motherboard. See the previous pages for the actual specifications of your motherboard.

## 1.2 Processor and Chipset Overview

Built upon the functionality and capability of the Intel® E3-1500 v5 (E3-1585 v5/65W; E3-1585L v5/45W) series processors (Socket BGA 1440) and the Intel® C236 PCH, the X11SSH-GF/-GTF (-1585/-1585L) motherboard offers maximum I/O expandability, energy efficiency, and data reliability in a 14-nm process architecture, and is optimized for embedded storage solutions, networking applications, and cloud-computing platforms.

The Intel® E3-1500 v5 and PCH C236 platform supports the following features:

- ACPI Power Management Logic Support
- Intel® Turbo Boost Technology 2.0 Power Monitoring/Power Control, Turbo Time Parameter (TAU), and Platform Power Control
- Configurable TDP (cTDP) and Lower-Power Mode
- Adaptive Thermal Management/Monitoring
- PCI-E 3.0, SATA 3.0 with transfer rates of up to 6 Gb/s
- System Management Bus (SMBus) Specification Version 2.0
- Integrated Sensor Hub (ISH)
- Intel® Trusted Execution Technology (Intel® TXT)
- Intel® Rapid Storage Technology
- Intel® Virtualization Technology for Directed I/O (Intel® VT-d)

## 1.3 Special Features

This section describes the health monitoring features of the X11SSH-GF/-GTF motherboard. The motherboard has an onboard System Hardware Monitor chip that supports system health monitoring.

### Recovery from AC Power Loss

The Basic I/O System (BIOS) provides a setting that determines how the system will respond when AC power is lost and then restored to the system. You can choose for the system to remain powered off (in which case you must press the power switch to turn it back on), or for it to automatically return to the power-on state. See the Advanced BIOS Setup section for this setting. The default setting is Last State.

## 1.4 System Health Monitoring

This section describes the health monitoring features of the X11SSH-GF/-GTF (-1585/-1585L) motherboard. The motherboard has an onboard Baseboard Management Controller (BMC) chip that supports system health monitoring. Once a voltage becomes unstable, a warning is given or an error message is sent to the screen. The user can adjust the voltage thresholds to define the sensitivity of the voltage monitor.

### Onboard Voltage Monitors

The onboard voltage monitor will continuously scan crucial voltage levels. Once a voltage becomes unstable, it will give a warning or send an error message to the screen. Users can adjust the voltage thresholds to define the sensitivity of the voltage monitor. Real time readings of these voltage levels are all displayed in BIOS.

### Fan Status Monitor with Firmware Control

The system health monitor embedded in the BMC chip can check the RPM status of the cooling fans. The CPU and chassis fans are controlled via IPMI.

### Environmental Temperature Control

System Health sensors in the BMC monitor the temperatures and voltage settings of onboard processors and the system in real time via the IPMI interface. Whenever the temperature of the CPU or the system exceeds a user-defined threshold, system/CPU cooling fans will be turned on to prevent the CPU or the system from overheating.



**Note:** To avoid possible system overheating, please be sure to provide adequate air-flow to your system.

### System Resource Alert

This feature is available when used with SuperDoctor 5®. SuperDoctor 5 is used to notify the user of certain system events. For example, you can configure SuperDoctor 5 to provide you with warnings when the system temperature, CPU temperatures, voltages and fan speeds go beyond a predefined range.

## 1.5 ACPI Features

ACPI stands for Advanced Configuration and Power Interface. The ACPI specification defines a flexible and abstract hardware interface that provides a standard way to integrate power management features throughout a computer system including its hardware, operating system and application software. This enables the system to automatically turn on and off peripherals such as network cards, hard disk drives and printers.

In addition to enabling operating system-directed power management, ACPI also provides a generic system event mechanism for Plug and Play and an operating system-independent interface for configuration control.

## 1.6 Power Supply

As with all computer products, a stable power source is necessary for proper and reliable operation. It is even more important for processors that have high CPU clock rates. In areas where noisy power transmission is present, you may choose to install a line filter to shield the computer from noise. It is recommended that you also install a power surge protector to help avoid problems caused by power surges.

## 1.7 Super I/O

The Super I/O (ASpeed AST2400 chip) includes a data separator, write pre-compensation circuitry, decode logic, data rate selection, a clock generator, drive interface control logic and interrupt and DMA logic.

The Super I/O Support 2 sets high-speed, 16550 compatible serial communication ports (UARTs), which includes support port 80h (programmable address) snoop feature with 128 bytes FIFO mode or DMA mode.

The Super I/O provides functions that comply with ACPI (Advanced Configuration and Power Interface), which includes support of legacy and ACPI power management through a SMI or SCI function pin. It also features auto power management to reduce power consumption. The IRQs, DMAs and I/O space resources of the Super I/O can be flexibly adjusted to meet ISA PnP requirements, which support ACPI and APM (Advanced Power Management).

## 1.8 Advanced Power Management

The following new advanced power management features are supported by the motherboard.

### **Intel® Intelligent Power Node Manager (IPNM)**

Available when the Supermicro Power Manager (SPM) is installed, Intel's Intelligent Power Node Manager (IPNM) provides your system with real-time thermal control and power management for maximum energy efficiency. Although IPNM Specification Version 2.0/3.0 is supported by the BMC (Baseboard Management Controller), your system must also have IPNM-compatible Management Engine (ME) firmware installed to use this feature.



**Note:** Support for IPNM 2.0/3.0 support is dependent on the power supply used in the system.

### **Management Engine (ME)**

The Management Engine, which is an ARC controller embedded in the IOH (I/O Hub), provides Server Platform Services (SPS) to your system. The services provided by SPS are different from those provided by the ME on client platforms.

## Chapter 2

# Installation

### 2.1 Static-Sensitive Devices

Electrostatic Discharge (ESD) can damage electronic components. To prevent damage to your motherboard, it is important to handle it very carefully. The following measures are generally sufficient to protect your equipment from ESD.

#### Precautions

- Use a grounded wrist strap designed to prevent static discharge.
- Touch a grounded metal object before removing the motherboard from the antistatic bag.
- Handle the motherboard by its edges only; do not touch its components, peripheral chips, memory modules or gold contacts.
- When handling chips or modules, avoid touching their pins.
- Put the motherboard and peripherals back into their antistatic bags when not in use.
- For grounding purposes, make sure that your chassis provides excellent conductivity between the power supply, the case, the mounting fasteners and the motherboard.
- Use only the correct type of CMOS onboard battery as specified by the manufacturer. Do not install the CMOS battery upside down, which may result in a possible explosion.

#### Unpacking

The motherboard is shipped in antistatic packaging to avoid static damage. When unpacking the motherboard, make sure that the person handling it is static-protected.

## 2.2 Motherboard Installation

All motherboards have standard mounting holes to fit different types of chassis. Make sure that the locations of all the mounting holes for both the motherboard and the chassis match. Although a chassis may have both plastic and metal mounting fasteners, metal ones are highly recommended because they ground the motherboard to the chassis. Make sure that the metal standoffs click in or are screwed in tightly.



Philips  
Screwdriver (1)

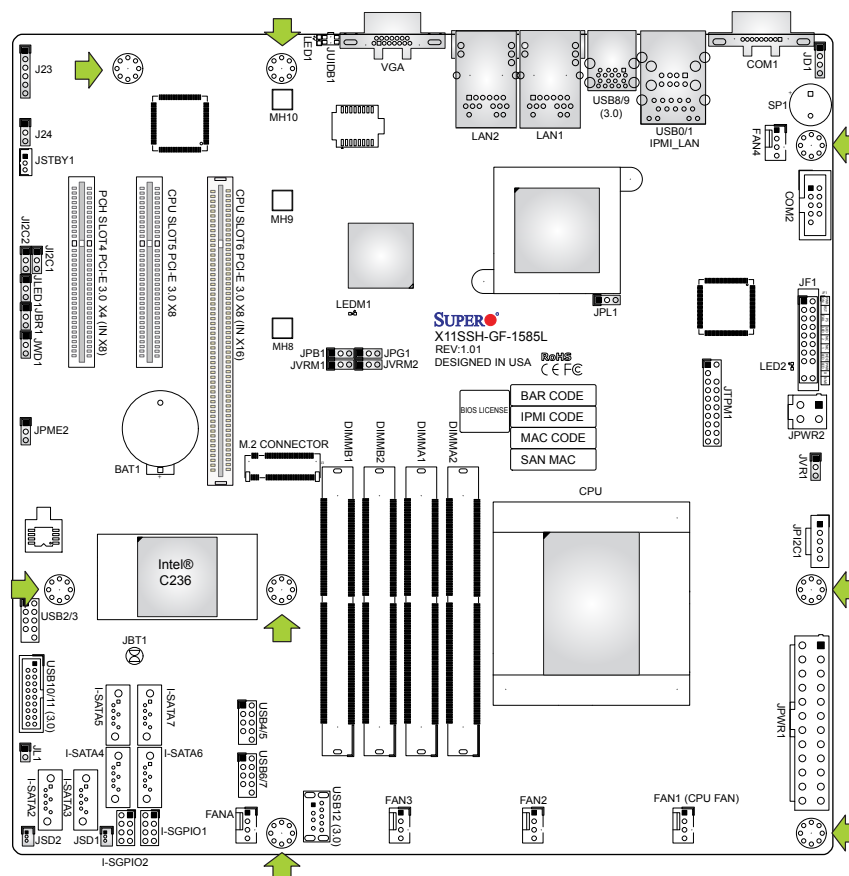


Philips Screws (8)



Standoffs (8)  
Only if Needed

### Tools Needed



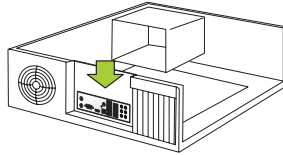
### Location of Mounting Holes



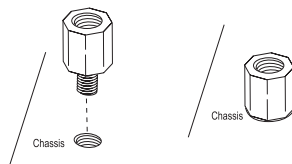
**Note:** 1) To avoid damaging the motherboard and its components, please do not use a force greater than 8 lb/inch on each mounting screw during motherboard installation.  
2) Some components are very close to the mounting holes. Please take precautionary measures to avoid damaging these components when installing the motherboard to the chassis.

## Installing the Motherboard

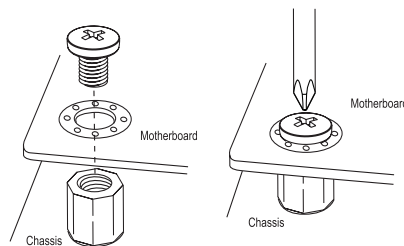
1. Install the I/O shield into the back of the chassis.




2. Locate the mounting holes on the motherboard. See the previous page for the location.



3. Locate the matching mounting holes on the chassis. Align the mounting holes on the motherboard against the mounting holes on the chassis.



4. Install standoffs in the chassis as needed.
5. Install the motherboard into the chassis carefully to avoid damaging other motherboard components.
6. Using the Phillips screwdriver, insert a Phillips head #6 screw into a mounting hole on the motherboard and its matching mounting hole on the chassis.
7. Repeat Step 5 to insert #6 screws into all mounting holes.
8. Make sure that the motherboard is securely placed in the chassis.

 **Note:** Images displayed are for illustration only. Your chassis or components might look different from those shown in this manual.



## 2.3 Memory Support and Installation



**Note:** Check the Supermicro website for recommended memory modules.



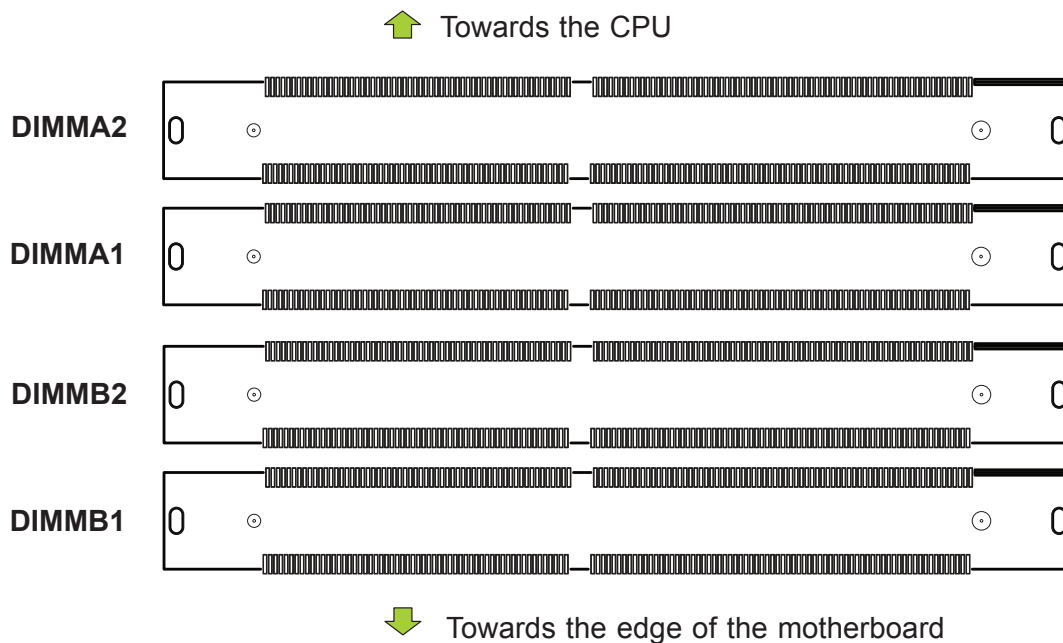
**Important:** Exercise extreme care when installing or removing DIMM modules to prevent any possible damage.

### Memory Support

The X11SSH-GF/-GTF (-1585/-1585L) supports up to 64GB of DDR4 ECC SO-DIMM 2400MHz memory. Populating these DIMM slots with a pair of memory modules of the same type and size will result in interleaved memory, which will improve memory performance.

### SO-DIMM Module Population Sequence

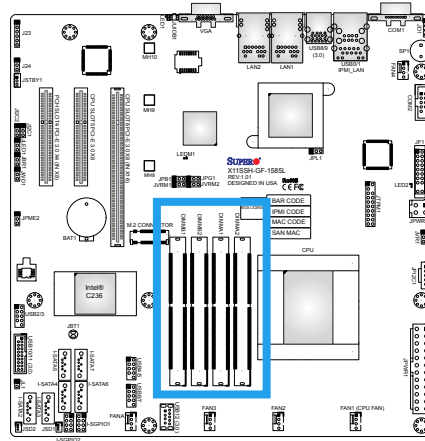
When installing memory modules, the DIMM slots must be populated in the following order: DIMMA1, DIMMB1, DIMMA2, and DIMMB2.



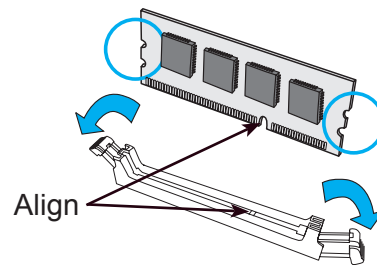
**Note:** Be sure to use memory modules of the same type and speed. Mixing of memory modules of different types and speeds is not allowed.

## SO-DIMM Installation

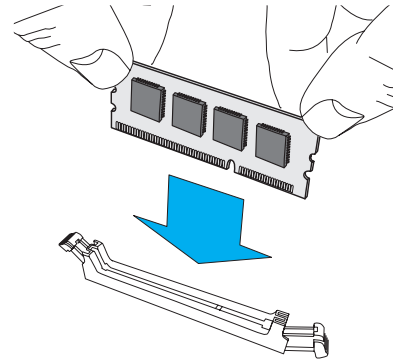
1. Insert SO-DIMM modules in the following order: DIMMA1, DIMMB1, DIMMA2, and DIMMB2. For the system to work properly, please use memory modules of the same type and speed.



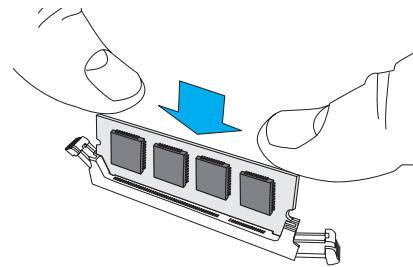
2. Position the bottom key of the SO-DIMM module so that it aligns with the receptive point on the slot. Take note of the side notches of the memory module and the locking clips of the socket.



3. Insert the SO-DIMM module straight down.

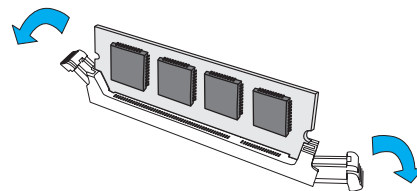


4. Press down until the module locks into place. The side clips will automatically secure the SO-DIMM module, locking it into proper place.



## SO-DIMM Removal

1. Gently push the side clips near both ends away from the module. Pull the SO-DIMM module up to remove it from the slot.



## 2.4 Rear I/O Ports

See Figure 2-2 below for the locations and descriptions of the various I/O ports on the rear of the motherboard.

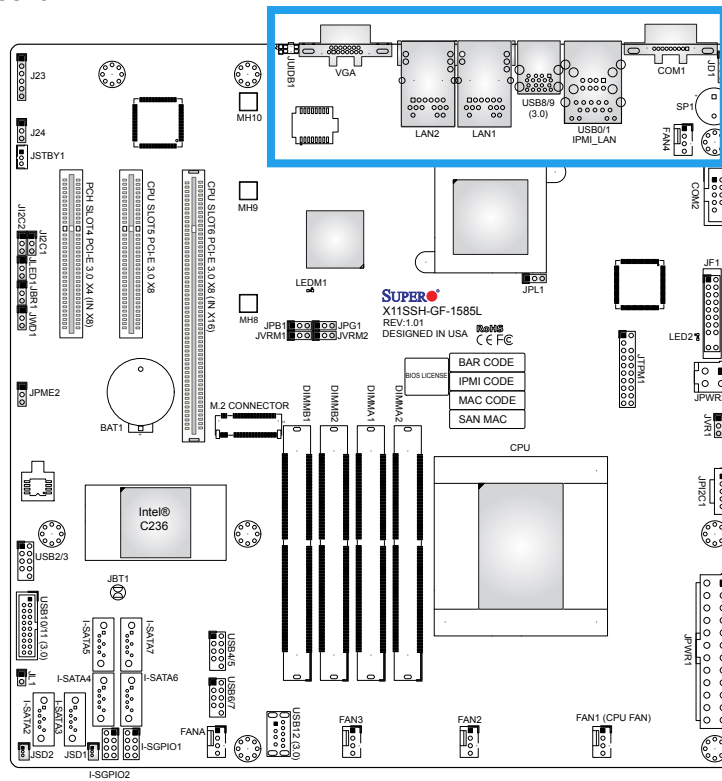
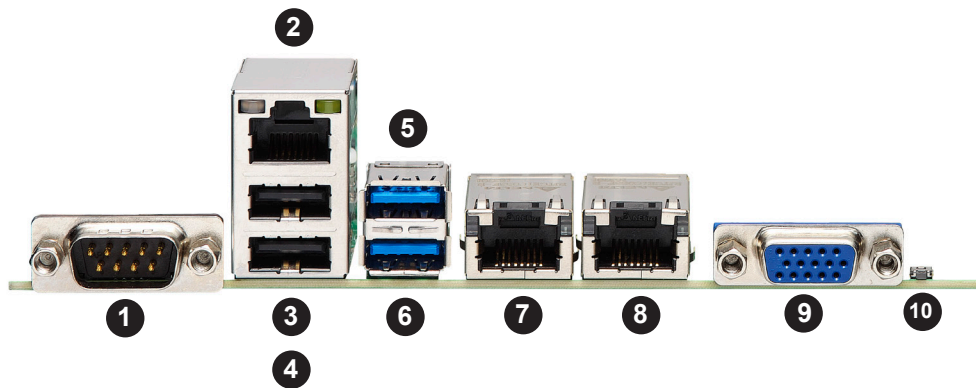


Figure 2-1. I/O Port Locations and Definitions

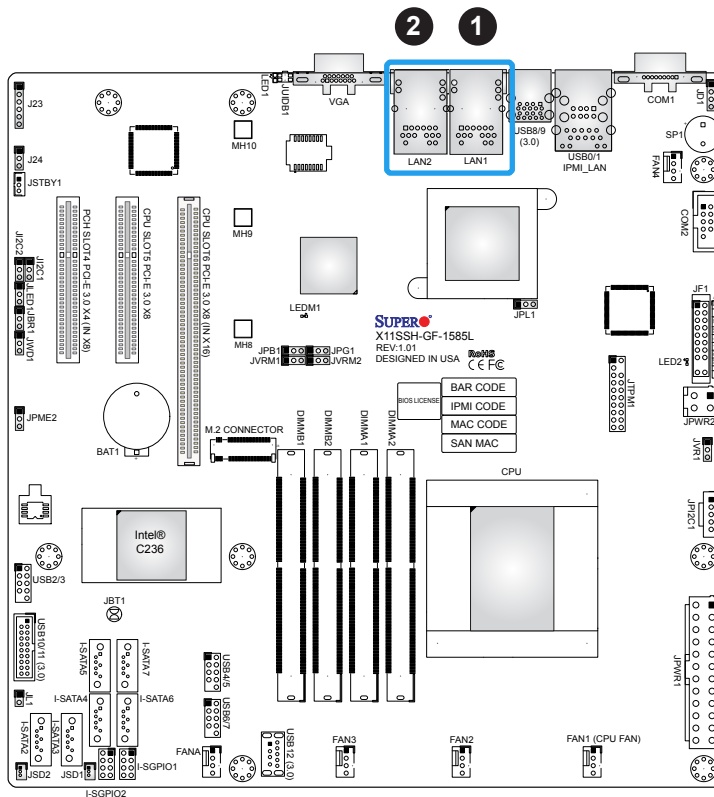


Rear I/O Ports			
#	Description	#	Description
1.	COM Port	6.	USB9 (3.0)
2.	IPMI LAN Port	7.	LAN1
3.	USB0	8.	LAN2
4.	USB1	9.	VGA Port
5.	USB8 (3.0)	10.	UID Switch

## LAN Ports

Two LAN ports (LAN1 ~ LAN2) are located on the I/O back panel. These ports accept RJ45 type cables. See the table below for pin definitions.

LAN1/2 Ports Pin Definions			
Pin #	Definition	Pin #	Definition
8	TRD1+		
7	TRCT1	19	L2-YEL-
9	TRD1-	21	L2GRE-
2	TRD2+	20	COMMON
1	TRCT2		
3	TRD2-	17	L1-GRE-
4	TRD3+	18	L1-GRE+
6	TRCT3		
5	TRD3-		
10	TRD4+		
12	TRCT4		
11	TRD4-	22	CG1
14	IET+	23	CG2
13	IETCT		
15	IET-		

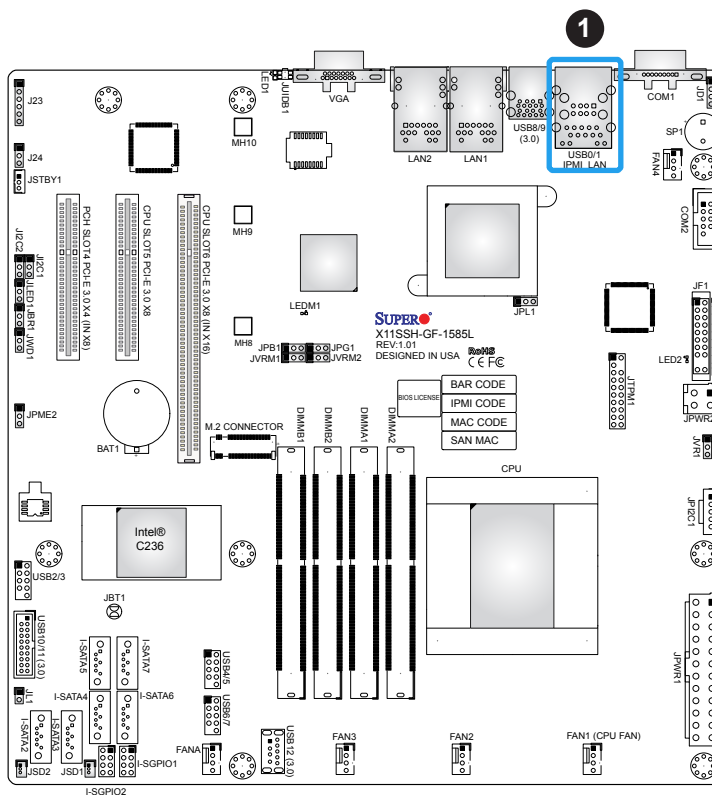


1. LAN1
2. LAN2

## IPMI LAN Port

There is one IPMI LAN port on the I/O back panel dedicated to the BMC (Baseboard Management Controller). This port accepts RJ45 type cables.

IPMI_LAN Pin Definition			
Pin #	Definition	Pin #	Definition
11	TX1-	20	YEL+
10	TX1+	19	YEL-
13	TX2-		
12	TX2+		
15		22	ORG-/GRN+
14	TD2+	21	ORG+GRN-
17	TX4-		
16	TX4+	23	SGND
9	VCC	24	SGND
18	GND	25	SGND
		26	SGND



1. IPMI LAN

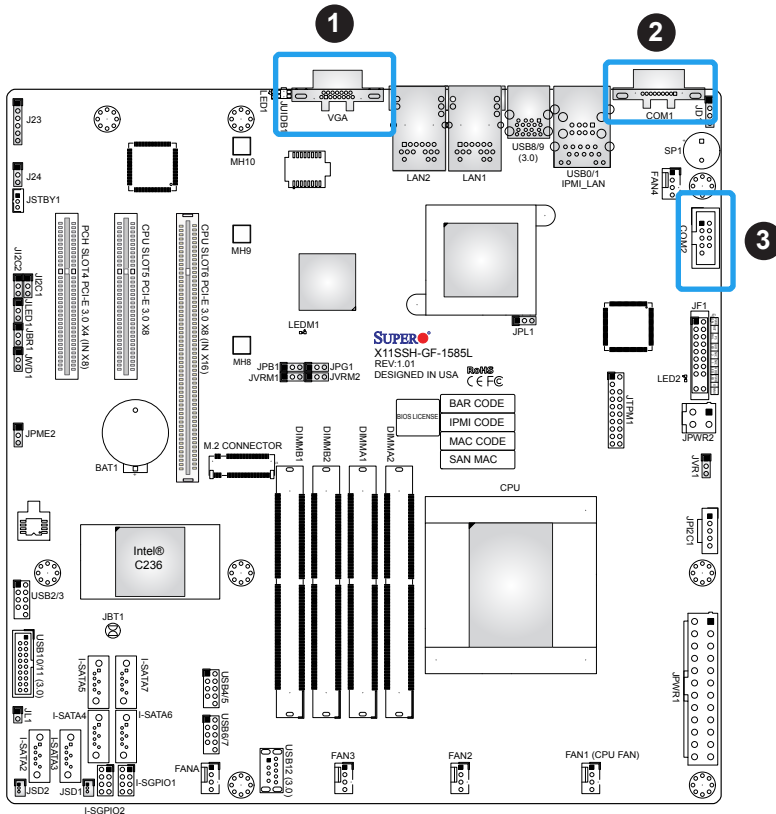
### VGA Port

A VGA port is located on the I/O back panel. This port is used to provide video display.

### Serial Ports

Serial port COM1 is located next to USB 0/1 on the I/O back panel. Another Serial port header (COM2) is on the motherboard. See the table below for pin definitions.

Serial Ports Pin Definitions			
Pin #	Definition	Pin #	Definition
1	DCD	6	DSR
2	RXD	7	RTS
3	TXD	8	CTS
4	DTR	9	RI
5	Ground	10	N/A



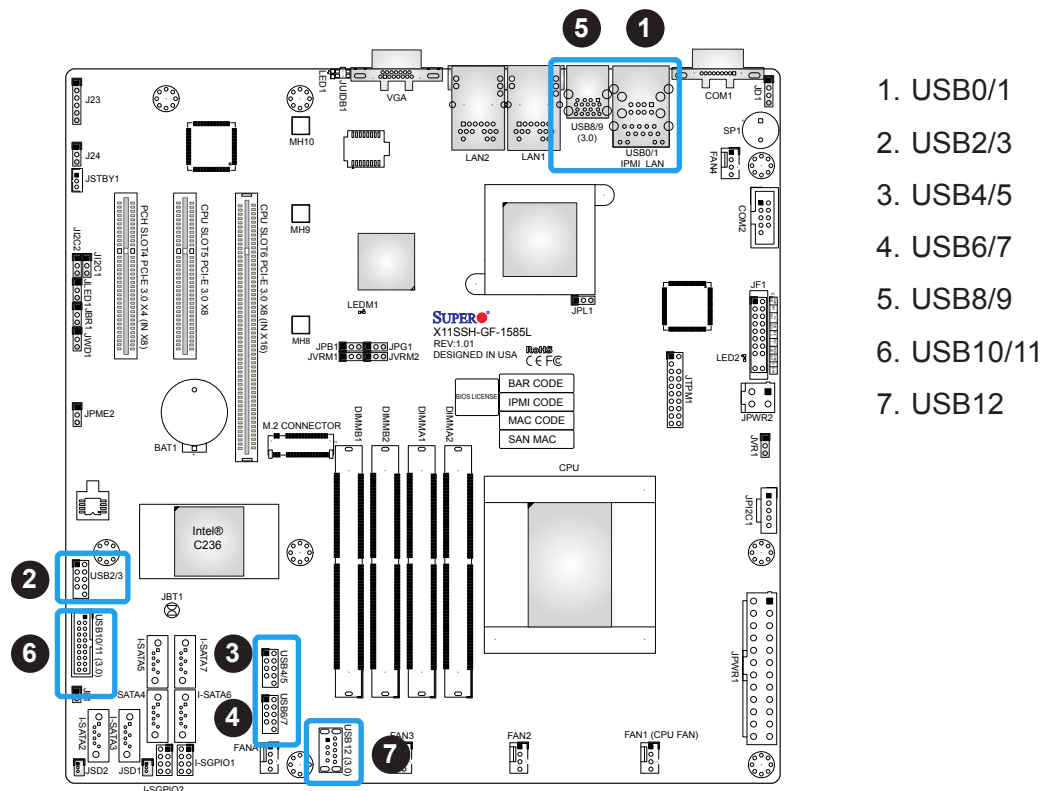
- 1. VGA
- 2. COM1
- 3. COM2

## USB Ports

This motherboard supports four USB 3.0 connections: two on the motherboard (USB 8/9), an another two on the I/O back panel (USB 0/1). A Type A USB connector (USB 12), located next to Fan3, also provides USB 3.0 support for front access. In addition, three USB 2.0 headers are also located on the motherboard and provide six USB 2.0 connections for front access support (USB 2/3, 4/5, 6/7). Refer to the layout below for the locations of USB ports. The onboard headers can be used to provide front side LAN USB access with a cable (not included).

Back Panel USB 3.0 Pin Definitions			
Pin#	Definition	Pin#	Definition
1	VBUS	10	Power
2	D-	11	USB 2.0 Differential Pair
3	D+	12	
4	Ground	13	Ground of PWR Return
5	StdA_SSRX-	14	SuperSpeed Receiver
6	StdA_SSRX+	15	Differential Pair
7	GND_DRAIN	16	Ground for Signal Return
8	StdA_SSTX-	17	SuperSpeed Transmitter
9	StdA_SSTX+	18	Differential Pair

Front Panel USB 2.0 Header Pin Definitions			
Pin#	Definition	Pin#	Definition
1	+5V	2	+5V
3	USB_PN2	4	USB_PN3
5	USB_PP2	6	USB_PP3
7	Ground	8	Ground
9	Key	10	Ground



## 2.5 Front Control Panel

JF1 contains header pins for various buttons and indicators that are normally located on a control panel at the front of the chassis. These connectors are designed specifically for use with Supermicro chassis. See the figure below for the descriptions of the front control panel buttons and LED indicators.

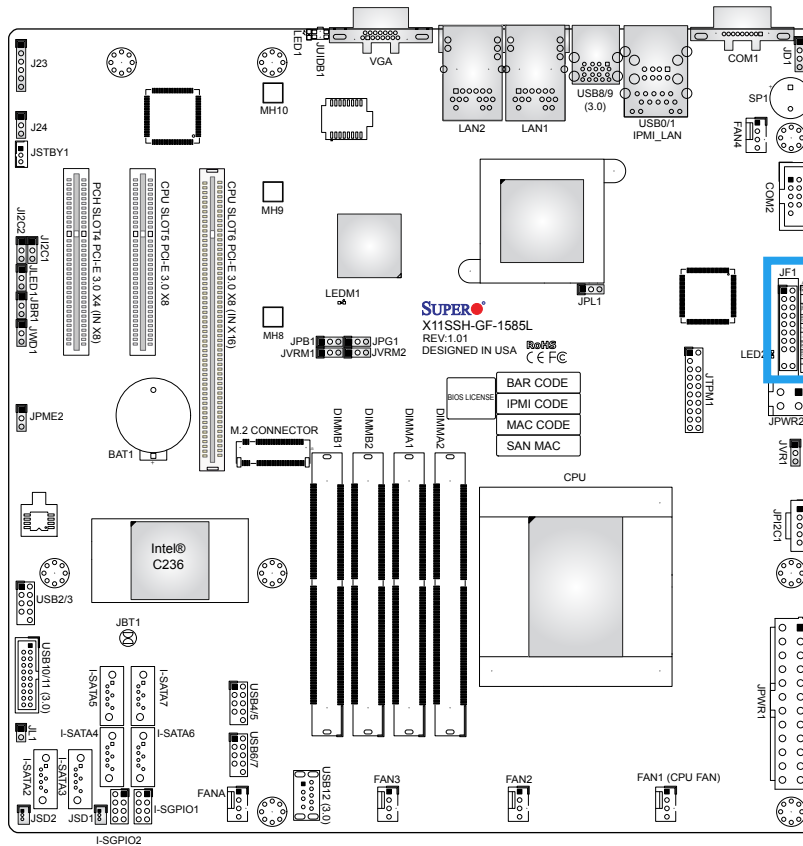


Figure 2-2. JF1 Header Pins

	1	2	
<b>PWR</b> } <b>Power Button</b>	○	○	<b>Ground</b>
<b>Reset</b> } <b>Reset Button</b>	○	○	<b>Ground</b>
<b>X</b>	○	○	<b>Power Supply Fail</b>
<b>3.3V Stby</b>	○	○	<b>UID LED</b>
<b>3.3V Stby</b>	○	○	<b>NIC2 Activity LED</b>
<b>3.3V Stby</b>	○	○	<b>NIC1 Activity LED</b>
<b>3.3V Stby</b>	○	○	<b>HDD LED</b>
<b>3.3V Stby</b>	○	○	<b>Power LED</b>
<b>X</b>	○	○	<b>X</b>
<b>NMI</b>	○	○	<b>Ground</b>
	19	20	



## Power LED

The Power LED connection is located on pins 15 and 16 of JF1. Refer to the table below for pin definitions.

Power LED Pin Definitions (JF1)	
Pin#	Definition
15	+3.3V Stby
16	Power LED

## HDD LED

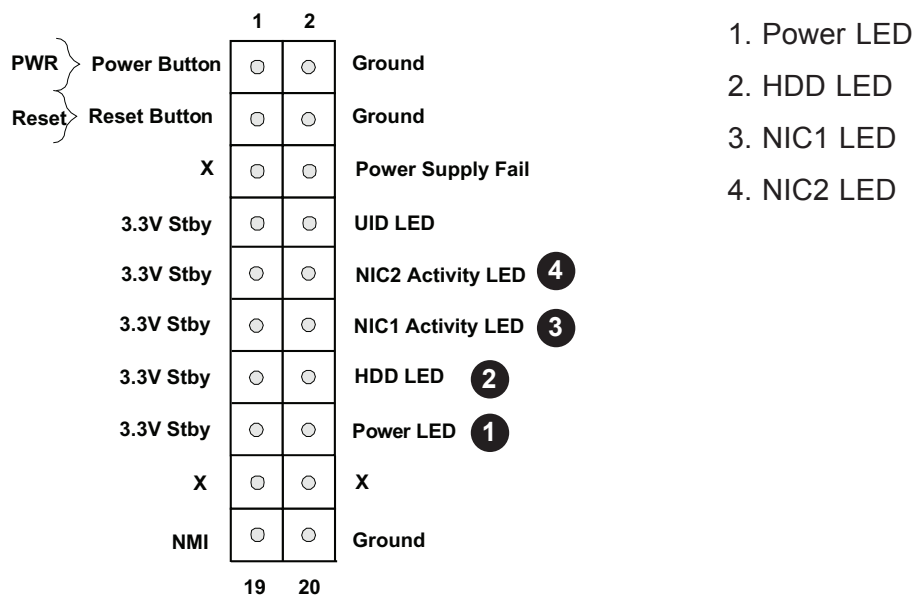
The HDD LED connection is located on pins 13 and 14 of JF1. Attach a cable here to indicate the status of HDD-related activities, including SATA activities. See the table below for pin definitions.

HDD LED Pin Definitions (JF1)	
Pin#	Definition
13	+3.3V Stby
14	HDD LED

## NIC1/NIC2 (LAN1/LAN2)

The NIC (Network Interface Controller) LED connection for LAN port 1 is located on pins 11 and 12 of JF1, and the LED connection for LAN Port 2 is on Pins 9 and 10. NIC1 LED and NIC2 LED are 2-pin NIC LED headers. Attach NIC LED cables to NIC1 and NIC2 LED indicators to display network activities. Refer to the table below for pin definitions.

LAN1/LAN2 LED Pin Definitions (JF1)	
Pin#	Definition
9/11	+3.3V Stby
10/12	NIC Activity LED



1. Power LED
2. HDD LED
3. NIC1 LED
4. NIC2 LED

### Reset Button

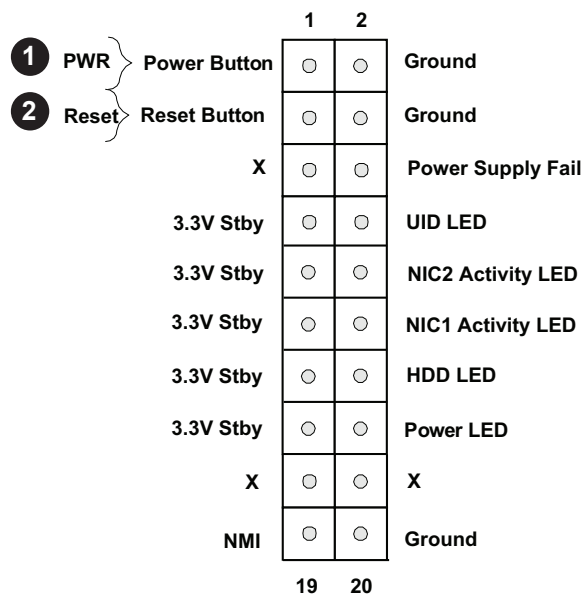
The Reset Button connection is located on pins 3 and 4 of JF1. Attach it to a hardware reset switch on the computer case to reset the system. Refer to the table below for pin definitions.

Reset Button Pin Definitions (JF1)	
Pin#	Definition
3	Reset
4	Ground

### Power Button

The Power Button connection is located on pins 1 and 2 of JF1. Momentarily contacting both pins will power on/off the system. This button can also be configured to function as a suspend button (with a setting in the BIOS - see Chapter 4). To turn off the power in the suspend mode, press the button for at least 4 seconds. Refer to the table below for pin definitions.

Power Button Pin Definitions (JF1)	
Pin#	Definition
1	Power
2	Ground



1. Power Button
2. Reset Button

## Power Supply Fail

Connect an LED cable to Power Supply Fail connections on pins 5 and 6 of JF1 to provide warnings for a power failure. Refer to the table below for pin definitions.

Power Supply Fail Indicator Status	
Pin#	Definition
5	X
6	Power Supply Fail

## UID LED Indicator

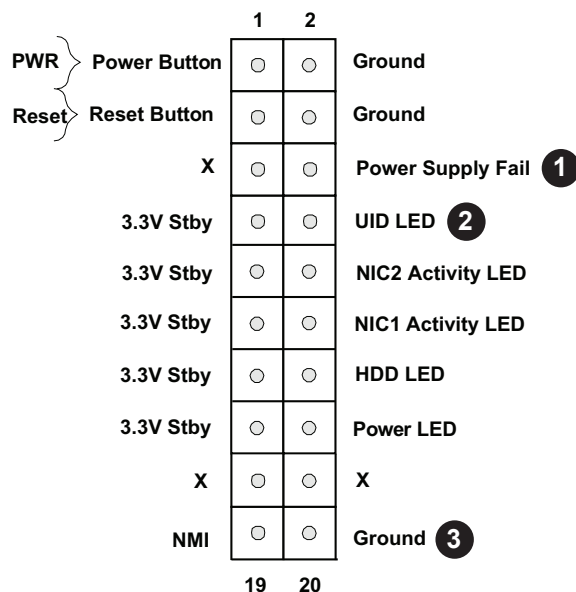
The UID (Unit Identifier) LED connection is located on pins 7 and 8 of JF1. The UID LED indicators provide easy identification of a system unit that may be in need of service.

UID LED Status	
Pin#	Definition
7	+3.3V Stby
8	NMI
Flashing	Fan Fail

## NMI Button

The NMI (Non-Maskable Interrupt) button is located on pins 19 and 20 of JF1. Refer to the table below for pin definitions.

NMI Button Pin Definitions	
Pin#	Definition
19	NMI
20	Ground



1. Power Supply Fail
2. UID LED
3. NMI Button

## 2.6 Connectors

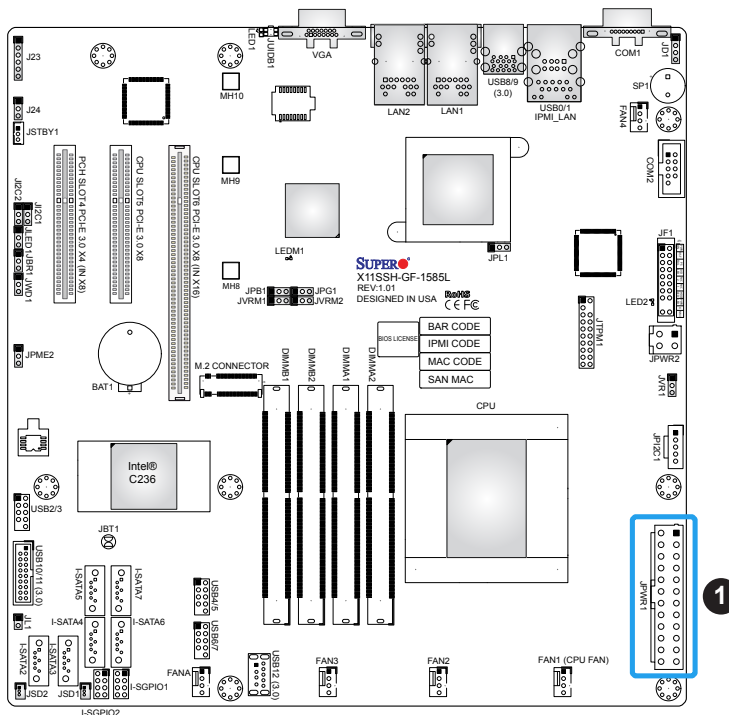
### Power Connections

#### Main ATX Power Supply Connector

The primary power supply connector (JPWR1) meets the ATX SSI EPS 24-pin specification. You must also connect the 4-pin (JPWR2) CPU power connector to your power supply.

ATX Power 24-pin Connector Pin Definitions			
Pin#	Definition	Pin#	Definition
13	+3.3V	1	+3.3V
14	-12V	2	+3.3V
15	COM	3	COM
16	PS_ON	4	+5V
17	COM	5	COM
18	COM	6	+5V
19	COM	7	COM
20	Res (NC)	8	PWR_OK
21	+5V	9	5VSB
22	+5V	10	+12V
23	+5V	11	+12V
24	COM	12	+3.3V

#### Required Connection



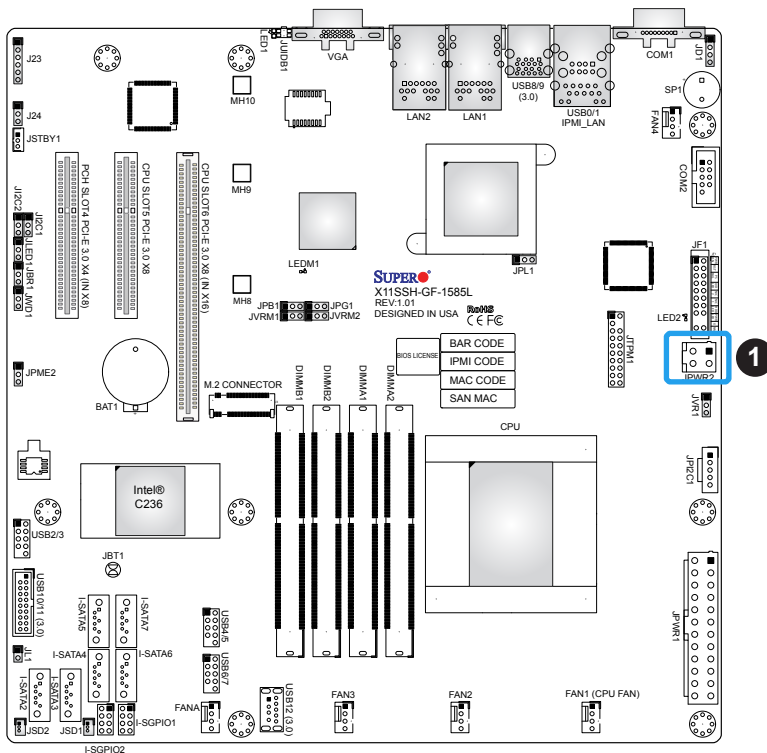
1. 24-Pin ATX Power Connector

## 12V DC Power Connector

JPWR2 must also be connected to the power supply. This connector is used to power the processor(s).

+12V 4-pin Power Pin Definitions	
Pin#	Definition
1-2	Ground
3-4	12V

### Required Connection



### 1. 4-Pin Secondary Power

## Headers

### Fan Headers

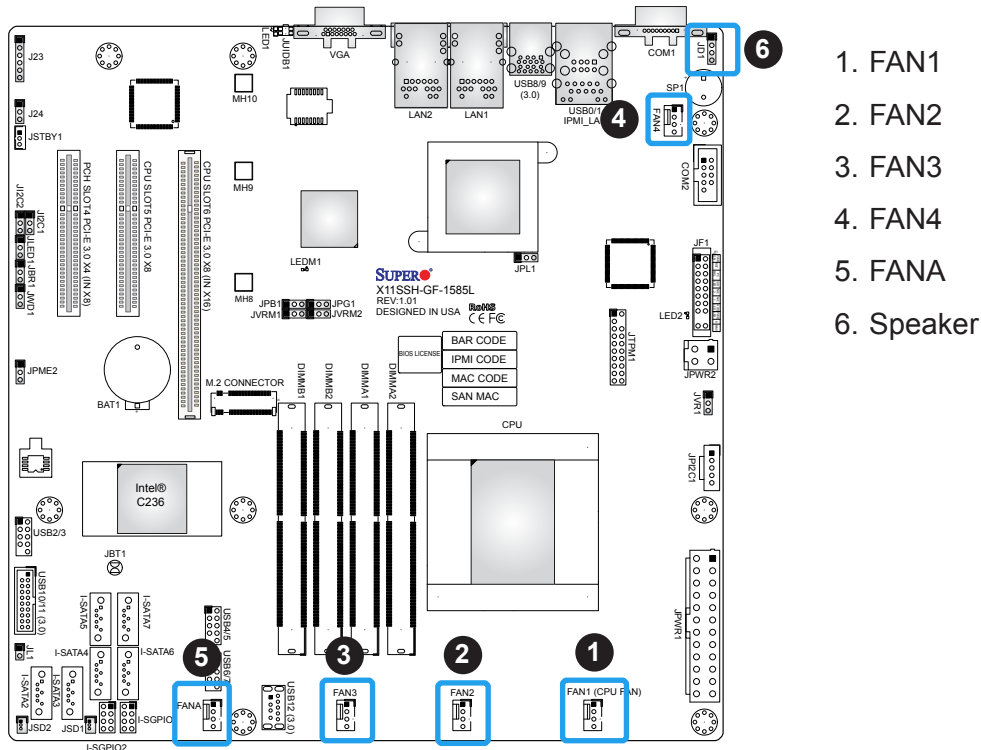
There are four 4-pin fan headers on the motherboard. Pins 1-3 of the fan header are backward-compatible with traditional 3-pin fans. Pin 4 of the fan is used for PWM (Pulse-Width Module) control support. The onboard fan speeds are controlled by Thermal Management (via Hardware Monitoring) in the BIOS. When using Thermal Management setting, please use all 3-pin fans or all 4-pin fans.

Fan Header Pin Definitions	
Pin#	Definition
1	Ground (Black)
2	+12V (Red)
3	Tachometer
4	PWM Control

### Speaker

On the JD1 header, pins 1-3 are used for power LED support. Close pins 1-4 to use the internal buzzer/speaker.

Speaker Connector Pin Definitions	
Pin Setting	Definition
Pins 1-4	Internal Speaker
Pins 1-3	Power LED



## Disk-On-Module Power Connector

The Disk-On-Module (DOM) power connectors at JSD1 and JSD2 provide 5V power to a solid-state DOM storage device connected to one of the SATA ports. See the table below for pin definitions.

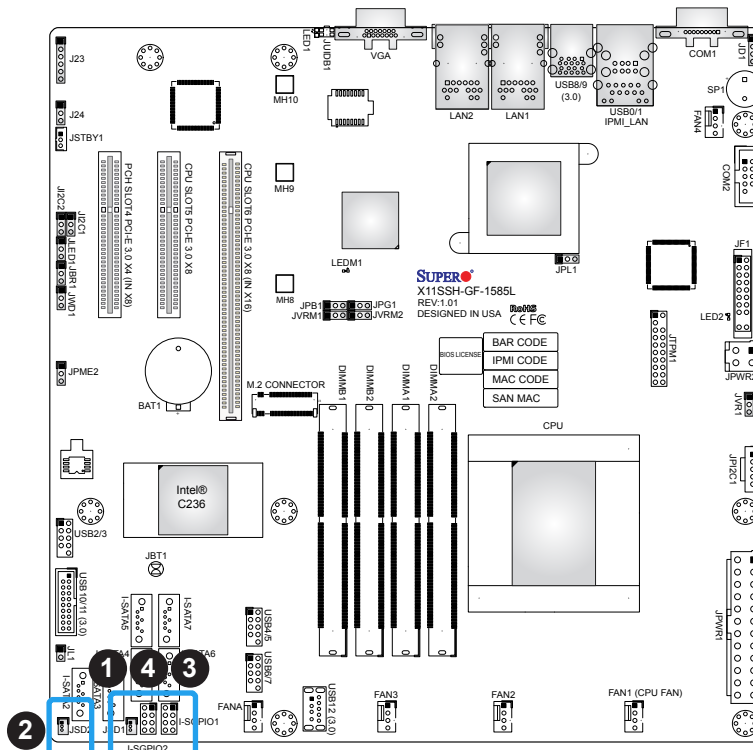
DOM Power Pin Definitions	
Pin#	Definition
1	5V
2	Ground
3	Ground

## Serial General Purpose I/O Headers

The I-SGPIO1 and I-SGPIO2 (Serial General Purpose Input/Output) headers are used to communicate with the enclosure management chip on the backplane.

SGPIO Header Pin Definitions			
Pin#	Definition	Pin#	Definition
1	NC	2	NC
3	Ground	4	DATA Out
5	Load	6	Ground
7	Clock	8	NC

NC = No Connection

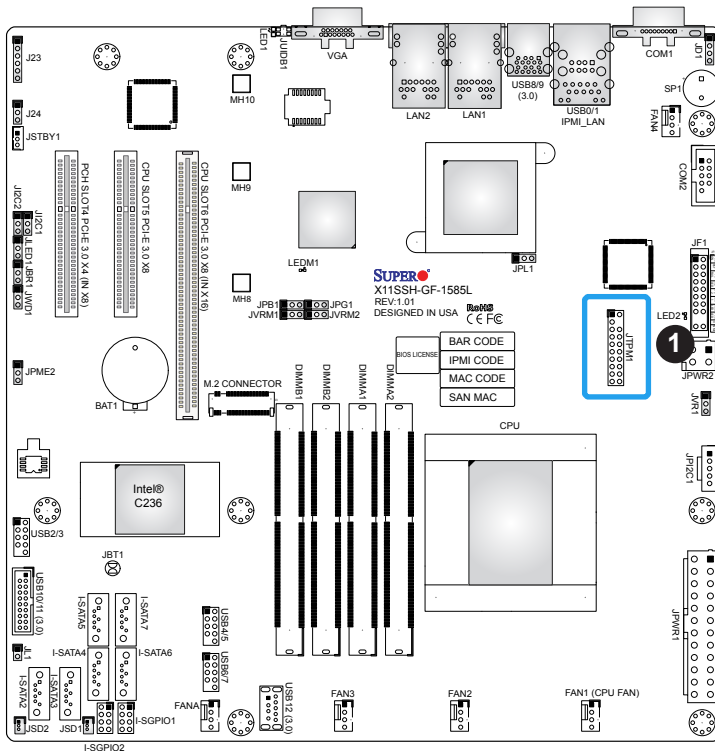


1. JSD1
2. JSD2
3. I-SGPIO1
4. I-SGPIO2

### TPM Header

The JTPM1 header is used to connect a Trusted Platform Module (TPM), which is available from a third-party vendor. A TPM is a security device that supports encryption and authentication in hard drives. It enables the motherboard to deny access if the TPM associated with the hard drive is not installed in the system. Please go to the following link for more information on TPM: <http://www.supermicro.com/manuals/other/TPM.pdf>. See the table below for pin definitions.

Trusted Platform Module Header Pin Definitions			
Pin#	Definition	Pin#	Definition
1	LCLK	2	GND
3	LFRAME#	4	No Pin
5	LRESET#	6	+5V (X)
7	LAD3	8	LAD2
9	3.3V	10	LAD1
11	LAD0	12	GND
13	SMB_CLK4 (X)	14	SMB_DAT4 (X)
15	P3V3_STBY	16	SERIRQ
17	GND	18	GND
19	P3V3_STBY	20	LDRQ# (X)



1. TPM Header



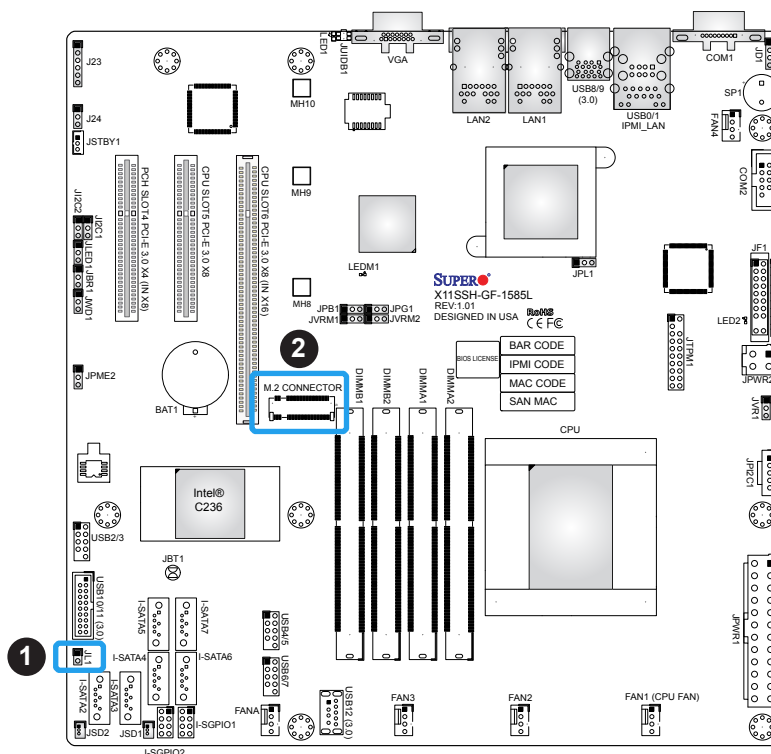
## Chassis Intrusion

A Chassis Intrusion header is located at JL1 on the motherboard. Attach the appropriate cable from the chassis to the header to inform you when the chassis is opened.

Chassis Intrusion Pin Definitions	
Pins	Definition
1	Intrusion Input
2	Ground

## M.2 Slot

M.2 is formerly known as Next Generation Form Factor (NGFF). The M.2 slot is designed for internal mounting devices. The X11SSH-GF/-GTF (-1585/-1585L) motherboard deploys an M key only dedicated for SSD devices with the ultimate performance capability for native PCI-E SSD support.




1. Chassis Intrusion
2. M.2 Slot

### SATA Ports

The X11SSH-GF/-GTF (-1585/-1585L) has six SATA 3.0 ports (I-SATA2 ~ I-SATA7) that are supported by the Intel® C236 chipset.

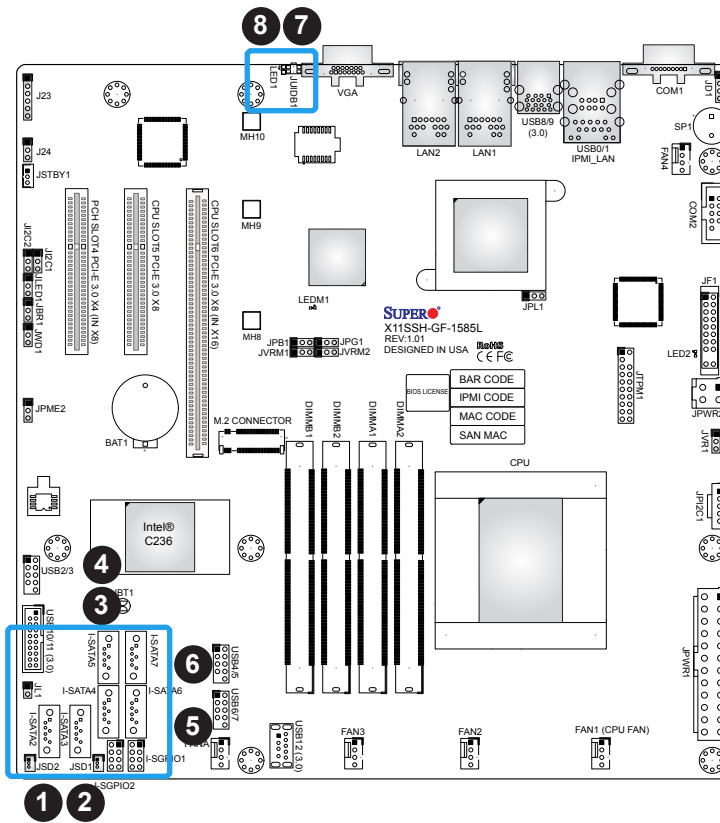
### Unit Identifier Switch/UID LED Indicator

A UID (Unit Identifier) switch and an LED indicator are located on the motherboard. The UID switch is located at JUIDB1, which is next to the VGA connector on the back panel. The UID LED (LED1) is located next to the UID switch. When you press the UID switch, the UID LED will be turned on. Press the UID switch again to turn off the LED indicator. The UID indicator provides easy identification of a system unit that may be in need of service.

 **Note:** UID can also be triggered via IPMI on the motherboard. For more information on IPMI, please refer to the IPMI User's Guide posted on our website at <http://www.supermicro.com>.

UID Switch	
Pin#	Definition
1	Ground
2	Ground
3	Button In
4	Button In

UID LED Status	
Color/State	Status
Blue: On	Unit Identified



1. I-SATA2
2. I-SATA3
3. I-SATA4
4. I-SATA5
5. I-SATA6
6. I-SATA7
7. UID Switch
8. UID LED

## Power SMB (I<sup>2</sup>C) Header

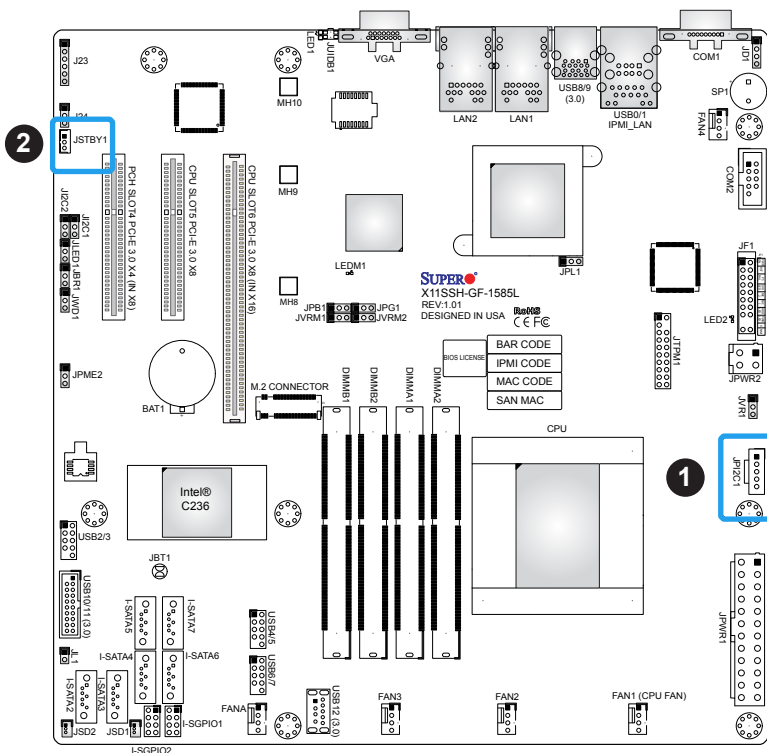
The Power System Management Bus (I<sup>2</sup>C) connector at JPI<sup>2</sup>C1 monitors the power supply, fan, and system temperatures. See the table below for pin definitions.

Power SMB Header Pin Definitions	
Pin#	Definition
1	Clock
2	Data
3	PMBUS_Alert
4	Ground
5	+3.3V

## Standby Power

The Standby Power header is located at JSTBY1 on the motherboard. See the layout below for the location.

Standby Power Pin Definitions	
Pin#	Definition
1	+5V Standby
2	Ground
3	No Connection

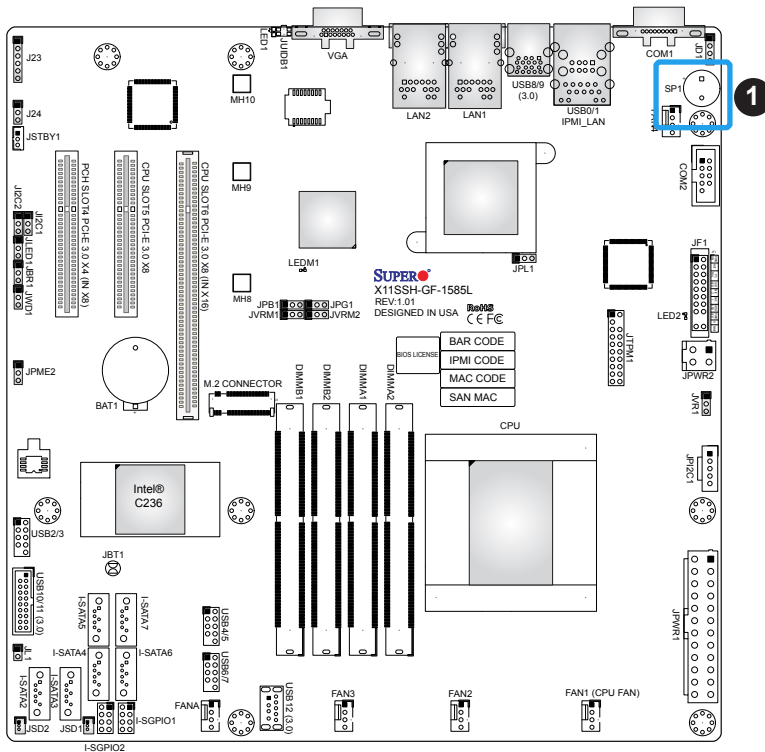


1. Power SMB Header
2. Standby Power

### Internal Speaker/Buzzer

The Internal Speaker/Buzzer (SP1) is used to provide audible indications for various beep codes. See the table on the right for pin definitions.

Internal Buzzer Pin Definition		
Pin#	Definitions	
1	Pos. (+)	Beep In
2	Neg. (-)	Alarm Speaker




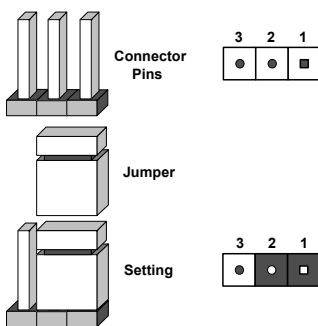
1. Internal Speaker/Buzzer

## 2.7 Jumper Settings

### How Jumpers Work

To modify the operation of the motherboard, jumpers can be used to choose between optional settings. Jumpers create shorts between two pins to change the function of the connector. Pin 1 is identified with a square solder pad on the printed circuit board. See the diagram at right for an example of jumping pins 1 and 2. Refer to the motherboard layout page for jumper locations.

 **Note:** On two-pin jumpers, "Closed" means the jumper is on and "Open" means the jumper is off the pins.




### CMOS Clear

JBT1 is used to clear CMOS, which will also clear any passwords. Instead of pins, this jumper consists of contact pads to prevent accidentally clearing the contents of CMOS.

#### To Clear CMOS

1. First power down the system and unplug the power cord(s).
2. Remove the cover of the chassis to access the motherboard.
3. Remove the onboard battery from the motherboard.
4. Short the CMOS pads with a metal object such as a small screwdriver for at least four seconds.
5. Remove the screwdriver (or shorting device).
6. Replace the cover, reconnect the power cord(s), and power on the system.

 **Note:** Clearing CMOS will also clear all passwords.

Do not use the PW\_ON connector to clear CMOS.




### SMBus to PCI Slots

Jumpers JI<sup>2</sup>C1 and JI<sup>2</sup>C2 allow you to connect the System Management Bus (I<sup>2</sup>C) to the PCI-E/PCI slots. Both jumpers must be set to the same setting (JI<sup>2</sup>C1 controls the clock and JI<sup>2</sup>C2 controls the data).

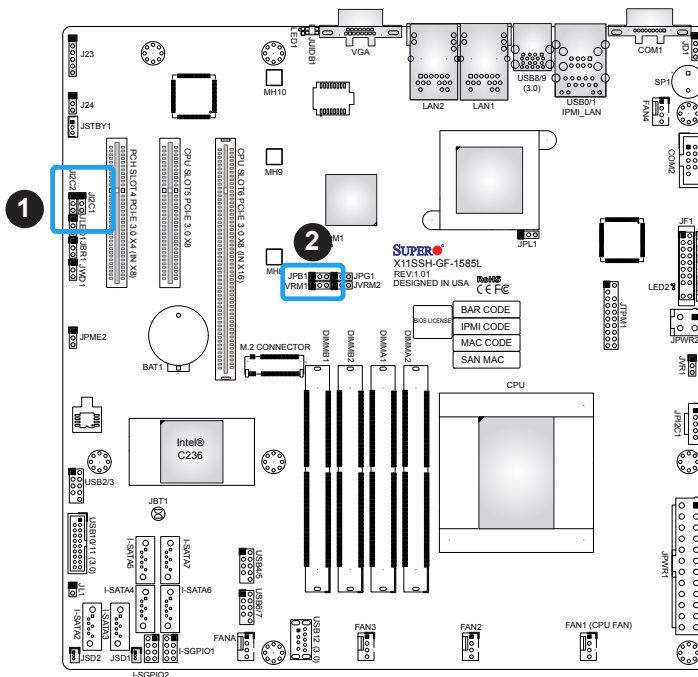
SMBus to PCI Slots Jumper Settings		
JI <sup>2</sup> C1 Setting	JI <sup>2</sup> C2 Setting	Definition
JI <sup>2</sup> C1: Closed	JI <sup>2</sup> C2: Closed	Enabled
JI <sup>2</sup> C1: Open	JI <sup>2</sup> C2: Open	Disabled

### BMC Enable/Disable

JPB1 is used to enable or disable the BMC (Baseboard Management Control) chip and the onboard IPMI connection. This jumper is used together with the IPMI settings in the BIOS. After the BMC is disabled, IPMI health monitoring and remote management functions are no longer supported. This jumper is for debugging only.

 **Note:** Please always keep BMC enabled to make sure the platform operates reliably with the health monitor.

BMC IPMI Enable/Disable Jumper Settings	
Pin #	Definition
1-2	Enabled (Default)
2-3	Disabled

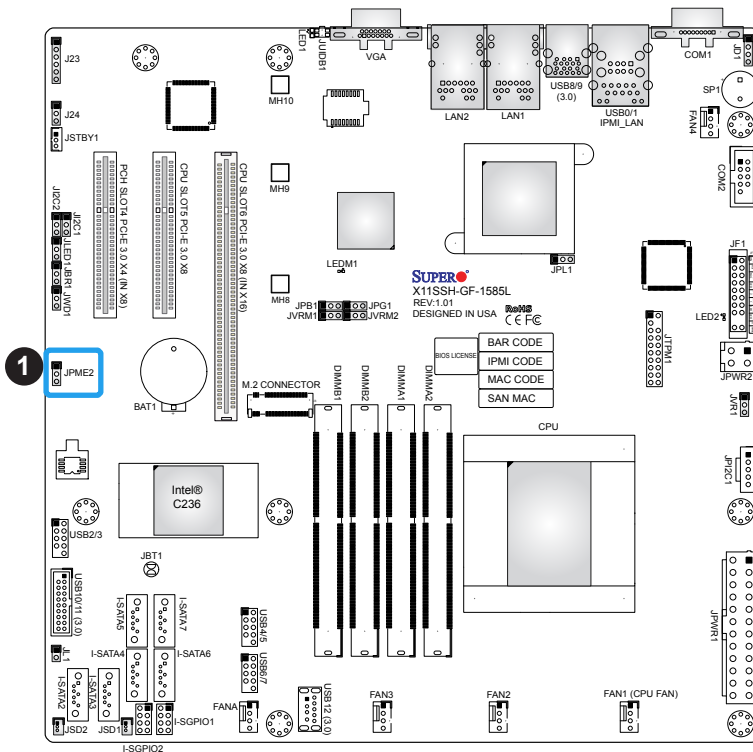


1. SMBus to PCI Slots
2. BMC Enable/Disable

## ME Manufacturing Mode

JPME2 allows you to bypass SPI flash security and force the system to use the Manufacturing Mode, which will allow you to flash the system firmware from a host server to modify system settings. Refer to the table below for jumper settings.


ME Recovery Jumper Settings	
Jumper Setting	Definition
Pins 1-2	Normal
Pins 2-3	Manufacturing Mode



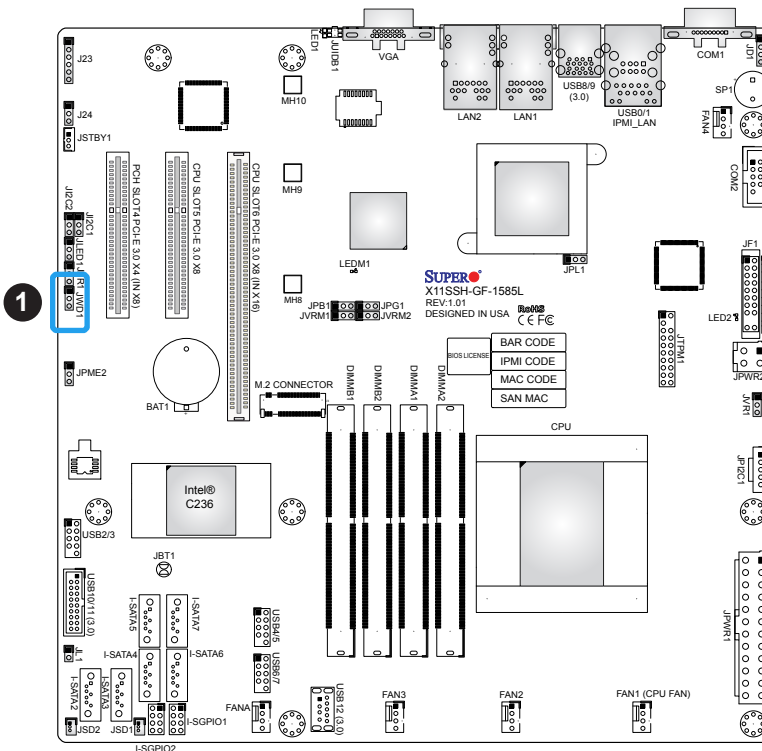
## 1. ME Manufacturing

## Watch Dog

JWD1 controls the Watch Dog function. Watch Dog is a monitor that can reboot the system when a software application hangs. Jumping pins 1-2 will cause Watch Dog to reset the system if an application hangs. Jumping pins 2-3 will generate a non-maskable interrupt signal for the application that hangs. Watch Dog must also be enabled in BIOS. The default setting is Reset.

 **Note:** When Watch Dog is enabled, the user needs to write their own application software to disable it.

Watch Dog Jumper Settings	
Jumper Setting	Definition
Pins 1-2	Reset
Pins 2-3	NMI
Open	Disabled



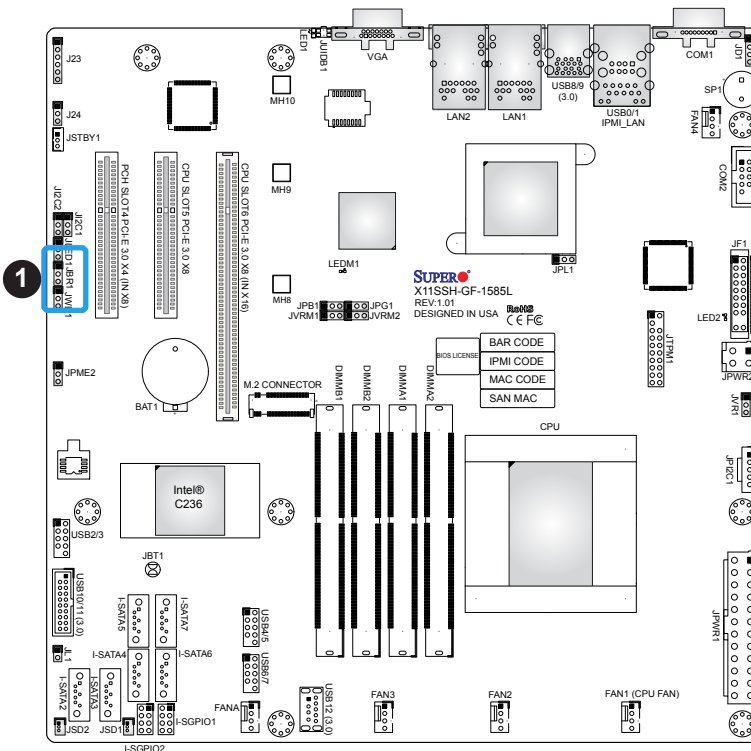
1. Watch Dog



## BIOS Recovery

Use jumper JBR1 to recover the BIOS settings. The default setting is Normal. See the table below for jumper settings.

BIOS Recovery Jumper Settings	
Jumper Setting	Definition
Pins 1-2	Normal
Pins 2-3	BIOS Recovery



### 1. BIOS Recovery

### VGA Connector

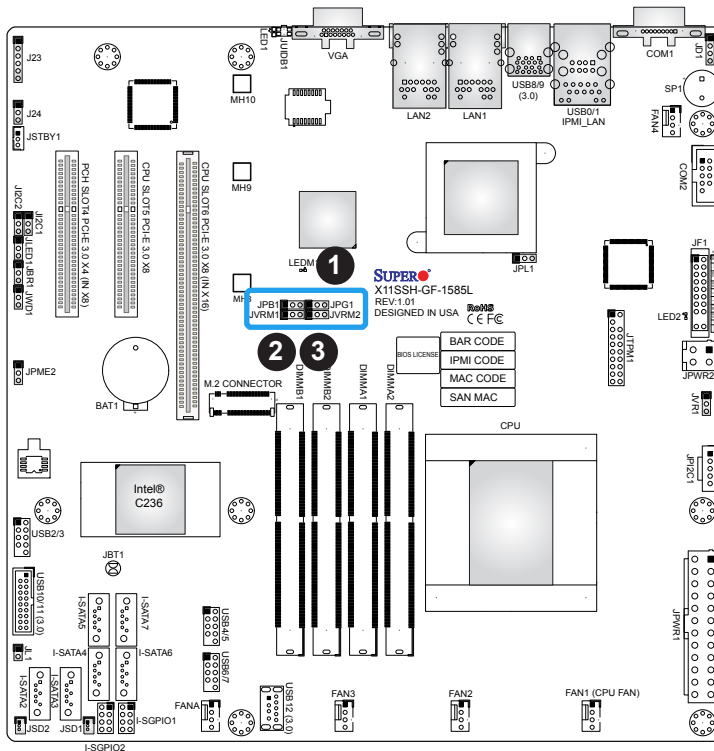
Jumper JPG1 allows the user to enable the onboard VGA connector. The default setting is pins 1-2 to enable the connection. See the table below for jumper settings.

VGA Enable Jumper Settings	
Jumper Setting	Definition
Pins 1-2	Enabled (Default)
Pins 2-3	Disabled

### I<sup>2</sup>C Bus for VRM

Set jumpers JVRM1 and JVRM2 for the BMC or the PCH to access CPU and memory VRM controllers. See the table below for jumper settings.

VRM Jumper Settings	
Jumper Setting	Definition
Pins 1-2	BMC (Normal)
Pins 2-3	PCH



1. VGA Enable
2. JVRM1
3. JVRM2

### Power LED Enable/Disable

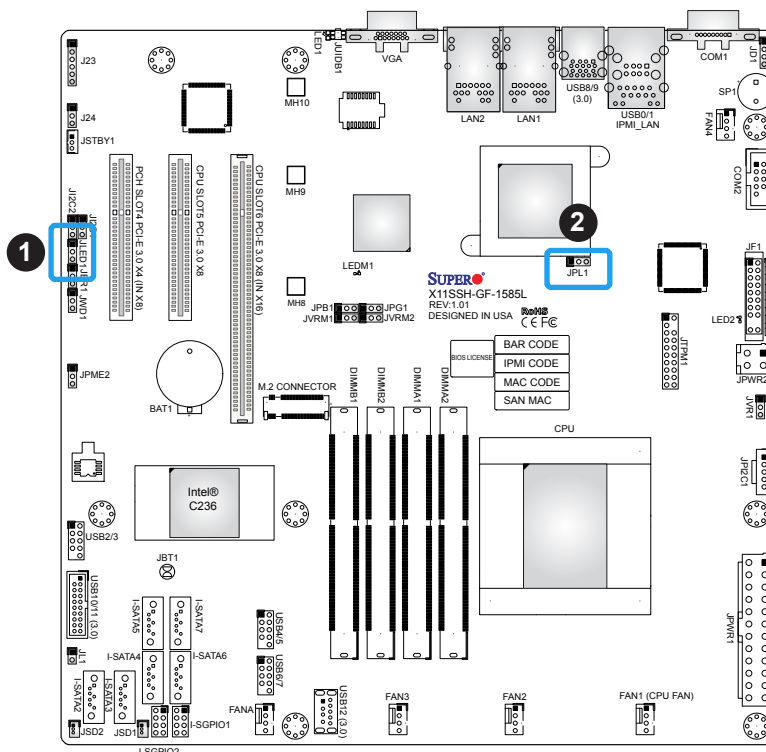
An onboard Power LED header is located at JLED1. This Power LED header is connected to the front control panel located at JF1 to indicate the status of system power. See the table below for pin definitions.

Onboard PWR LED Jumper Settings	
Jumper Setting	Definition
Pins 1-2	Enabled
Pins 2-3	Disabled

### LAN1/LAN2 Enable/Disable

Jumper JPL1 enables or disables LAN ports 1/2 on the motherboard. See the table below for jumper settings. The default setting is enabled.

LAN Enable Jumper Settings	
Jumper Setting	Definition
Pins 1-2	Enabled (default)
Pins 2-3	Disabled



1. Power LED
2. LAN1/2 Enable

## 2.8 LED Indicators

### Unit ID LED

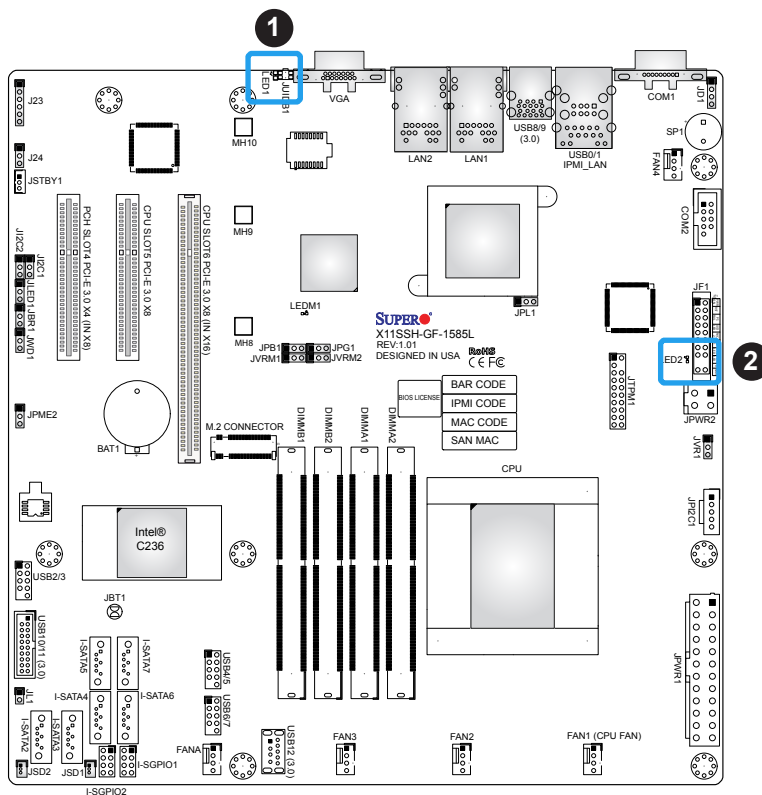
A rear UID LED indicator at LED1 is located next to the I/O back panel. The UID indicator provides easy identification of a system unit that may be in need of service. Refer to the table for the LED status.

UID LED Indicator	
LED Color	Definition
Blue: On	Unit Identified

### Onboard Power LED

LED2 is an Onboard Power LED. When this LED is lit, it means power is present on the motherboard. In suspend mode, this LED will blink on and off. Turn off the system and unplug the power cord before removing or installing components.

Onboard Power LED Indicator	
LED Color	Definition
Off	System Off (power cable not connected)
Green	System On



1. UID LED
2. Onboard Power LED

## BMC Heartbeat LED

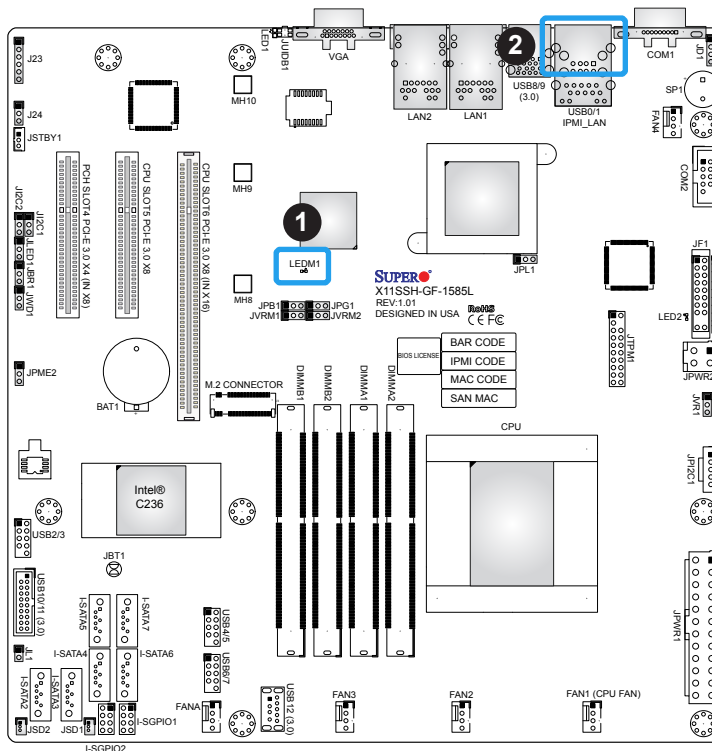
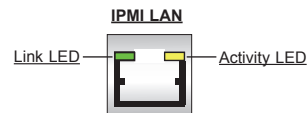
LED1 is the BMC heartbeat LED. When the LED is blinking green, BMC is functioning normally. See the table below for the LED status.

BMC Heartbeat LED Indicator	
LED Color	Definition
Green: Blinking	BMC Normal

## Dedicated IPMI LAN LED

A dedicated IPMI LAN is also included on the motherboard. The amber LED on the right of the IPMI LAN port indicates activity, while the left LED indicates the speed of the connection. Refer to the table below for more information.

IPMI LAN Link LED (Left) & Activity LED (Right)		
Color/State		Definition
Link (Left)	Amber: Solid	1 Gbps
	Green: Solid	100 Mbps
Activity (Right)	Yellow: Blinking	Active



1. LEDM1
2. IPMI LAN LED

# Chapter 3

## Troubleshooting

### 3.1 Troubleshooting Procedures

Use the following procedures to troubleshoot your system. If you have followed all of the procedures below and still need assistance, refer to the 'Technical Support Procedures' and/or 'Returning Merchandise for Service' section(s) in this chapter. Always disconnect the AC power cord before adding, changing or installing any non hot-swap hardware components.

#### Before Power On

1. Check if the power LED on the motherboard is on.
2. Make sure that the power connector is connected to your power supply.
3. Make sure that no short circuits exist between the motherboard and chassis.
4. Disconnect all cables from the motherboard, including those for the keyboard and mouse.
5. Remove all add-on cards.
6. Install a CPU, a heatsink<sup>\*(Note)</sup>, and connect the internal speaker and the power LED to the motherboard. Check all jumper settings as well. (Note: Make sure that the heatsink is fully seated.)
7. Use the correct type of onboard CMOS battery (CR2032) as recommended by the manufacturer. To avoid possible explosion, do not install the CMOS battery upside down.

#### No Power

1. Make sure that no short circuits exist between the motherboard and the chassis.
2. Verify that all jumpers are set to their default positions.
3. Check that the 115V/230V switch on the power supply is properly set.
4. Turn the power switch on and off to test the system.
5. The battery on your motherboard may be old. Check to verify that it still supplies ~3VDC. If it does not, replace it with a new one.

## No Video

1. If the power is on, but you have no video, remove all the add-on cards and cables.
2. Use the speaker to determine if any beep codes exist. Refer to Appendix A for details on beep codes.



**Note:** If you are a system integrator, VAR or OEM, a POST diagnostics card is recommended. For I/O port 80h codes, refer to Appendix B.

## System Boot Failure

If the system does not display POST (Power-On-Self-Test), or does not respond after the power is turned on, check the following:

1. Check for any error beep from the motherboard speaker.
  - If there is no error beep, try to turn on the system without DIMM modules installed. If there is still no error beep, replace the motherboard.
  - If there are error beeps, clear the CMOS settings by unplugging the power cord and contacting both pads on the CMOS Clear Jumper (JBT1). Refer to chapter 2.
2. Remove all components from the motherboard, especially the DIMM modules. Make sure that system power is on and that memory error beeps are activated.
3. Turn on the system with only one DIMM module installed. If the system boots, check for bad DIMM modules or slots by following the Memory Errors Troubleshooting procedure in this chapter.

## Memory Errors

1. Make sure that the DIMM modules are properly and fully installed.
2. Confirm that you are using the correct memory. Also, it is recommended that you use the same memory type and speed for all DIMMs in the system. See Section 2.4 for memory details.
3. Check for bad DIMM modules or slots by swapping modules between slots and note the results.
4. Check the power supply voltage 115V/230V switch.

## Losing the System's Setup Configuration

1. Make sure that you are using a high quality power supply. A poor quality power supply may cause the system to lose the CMOS setup information. Refer to Section 1.5 for details on recommended power supplies.
2. The battery on your motherboard may be old. Check to verify that it still supplies ~3VDC. If it does not, replace it with a new one.
3. If the above steps do not fix the setup configuration problem, contact your vendor for repairs.

## When the System Becomes Unstable

### ***A. If the system becomes unstable during or after OS installation, check the following:***

1. CPU/BIOS support: Make sure that your CPU is supported and that you have the latest BIOS installed in your system.
2. Memory support: Make sure that the memory modules are supported by testing the modules using memtest86 or a similar utility.



**Note:** Refer to the product page on our website at <http://www.supermicro.com> for memory and CPU support and updates.

3. HDD support: Make sure that all hard disk drives (HDDs) work properly. Replace the bad HDDs with good ones.
4. System cooling: Check the system cooling to make sure that all heatsink fans and CPU/system fans, etc., work properly. Check the hardware monitoring settings in the IPMI to make sure that the CPU and system temperatures are within the normal range. Also check the front panel Overheat LED and make sure that it is not on.
5. Adequate power supply: Make sure that the power supply provides adequate power to the system. Make sure that all power connectors are connected. Please refer to our website for more information on the minimum power requirements.
6. Proper software support: Make sure that the correct drivers are used.

### ***B. If the system becomes unstable before or during OS installation, check the following:***

1. Source of installation: Make sure that the devices used for installation are working properly, including boot devices such as CD/DVD and CD/DVD-ROM.
2. Cable connection: Check to make sure that all cables are connected and working properly.



3. Using the minimum configuration for troubleshooting: Remove all unnecessary components (starting with add-on cards first), and use the minimum configuration (but with a CPU and a memory module installed) to identify the trouble areas. Refer to the steps listed in Section A above for proper troubleshooting procedures.
4. Identifying bad components by isolating them: If necessary, remove a component in question from the chassis, and test it in isolation to make sure that it works properly. Replace a bad component with a good one.
5. Check and change one component at a time instead of changing several items at the same time. This will help isolate and identify the problem.
6. To find out if a component is good, swap this component with a new one to see if the system will work properly. If so, then the old component is bad. You can also install the component in question in another system. If the new system works, the component is good and the old system has problems.

## 3.2 Technical Support Procedures

Before contacting Technical Support, please take the following steps. Also, note that as a motherboard manufacturer, we do not sell directly to end-users, so it is best to first check with your distributor or reseller for troubleshooting services. They should know of any possible problem(s) with the specific system configuration that was sold to you.

1. Please review the 'Troubleshooting Procedures' and 'Frequently Asked Questions' (FAQs) sections in this chapter or see the FAQs on our website before contacting Technical Support.
2. BIOS upgrades can be downloaded from our website. **Note:** Not all BIOS can be flashed depending on the modifications to the boot block code.
3. If you still cannot resolve the problem, include the following information when contacting us for technical support:
  - Motherboard model and PCB revision number
  - BIOS release date/version (this can be seen on the initial display when your system first boots up)
  - System configuration

An example of a Technical Support form is posted on our website.

Distributors: For immediate assistance, please have your account number ready when contacting our technical support department by e-mail.

### 3.3 Frequently Asked Questions

**Question: What type of memory does my motherboard support?**

**Answer:** The X11SSH-GF/-GTF (-1585/-1585L) motherboard supports up to 64GB of DDR4 ECC SO-DIMM 2400MHz. See Section 2.3 for details on installing memory.

**Question: How do I update my BIOS?**

**Answer:** It is recommended that you **do not** upgrade your BIOS if you are not experiencing any problems with your system. Updated BIOS files are located on our website at <http://www.supermicro.com>. Please check our BIOS warning message and the information on how to update your BIOS on our website. Select your motherboard model and download the BIOS file to your computer. Also, check the current BIOS revision to make sure that it is newer than your BIOS before downloading. You can choose from the zip file and the .exe file. If you choose the zip BIOS file, please unzip the BIOS file onto a bootable USB device. Run the batch file using the format FLASH.BAT filename.rom from your bootable USB device to flash the BIOS. Then, your system will automatically reboot.

**Question: Why can't I turn off the power using the momentary power on/off switch?**

**Answer:** The instant power off function is controlled in BIOS by the Power Button Mode setting. When the On/Off feature is enabled, the motherboard will have instant off capabilities as long as the BIOS has control of the system. When the Standby or Suspend feature is enabled or when the BIOS is not in control such as during memory count (the first screen that appears when the system is turned on), the momentary on/off switch must be held for more than four seconds to shut down the system. This feature is required to implement the ACPI features on the motherboard.

## 3.4 Battery Removal and Installation

### Battery Removal

To remove the onboard battery, follow the steps below:

1. Power off your system and unplug your power cable.
2. Locate the onboard battery as shown below.
3. Using a tool such as a pen or a small screwdriver, push the battery lock outwards to unlock it. Once unlocked, the battery will pop out from the holder.
4. Remove the battery.

### Proper Battery Disposal

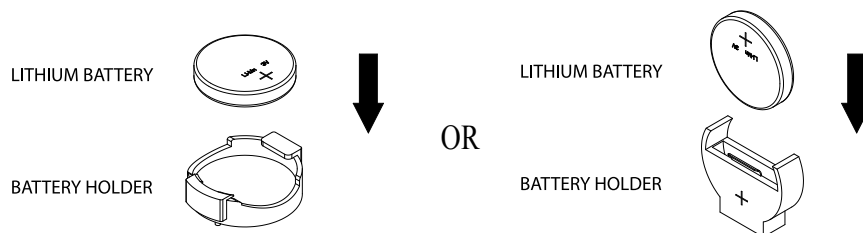
Please handle used batteries carefully. Do not damage the battery in any way; a damaged battery may release hazardous materials into the environment. Do not discard a used battery in the garbage or a public landfill. Please comply with the regulations set up by your local hazardous waste management agency to dispose of your used battery properly.

### Battery Installation

1. To install an onboard battery, follow the steps 1 & 2 above and continue below:
2. Identify the battery's polarity. The positive (+) side should be facing up.
3. Insert the battery into the battery holder and push it down until you hear a click to ensure that the battery is securely locked.



**Important:** When replacing a battery, be sure to only replace it with the same type.



### 3.5 Returning Merchandise for Service

A receipt or copy of your invoice marked with the date of purchase is required before any warranty service will be rendered. You can obtain service by calling your vendor for a Returned Merchandise Authorization (RMA) number. When returning to the manufacturer, the RMA number should be prominently displayed on the outside of the shipping carton and mailed prepaid or hand-carried. Shipping and handling charges will be applied for all orders that must be mailed when service is complete.

For faster service, RMA authorizations may be requested online (<http://www.supermicro.com/support/rma/>).

This warranty only covers normal consumer use and does not cover damages incurred in shipping or from failure due to the alteration, misuse, abuse or improper maintenance of products.

During the warranty period, contact your distributor first for any product problems.

## Chapter 4

### BIOS

#### 4.1 Introduction

This chapter describes the AMIBIOS™ setup utility for the X11SSH-GF/-GTF (-1585/-1585L) motherboard. The BIOS is stored on a Flash EEPROM and can be easily upgraded using a flash program.



**Note:** Due to periodic changes to the BIOS, some settings may have been added or deleted and might not yet be recorded in this manual. Please refer to the Manual Download area of our website for any changes to BIOS that may not be reflected in this manual.

#### Starting the Setup Utility

To enter the BIOS setup utility, enter the <Delete> key while the system is booting up. (In most cases, the <Delete> key is used to invoke the BIOS setup screen. There are a few cases when other keys are used, such as <F1>, <F2>, etc.) Each main BIOS menu option is described in this manual.

The main BIOS screen has two main frames. The left frame displays all the options that can be configured. “Grayed-out” options cannot be configured. The right frame displays the key legend. Above the key legend is an area reserved for a text message. When an option is selected in the left frame, it is highlighted in white. Often a text message will accompany it. Note that BIOS has default text messages built in. We retain the option to include, omit, or change any of these text messages. Settings printed in **Bold** are the default values.

A " ►" indicates a submenu. Highlighting such an item and pressing the <Enter> key will open the list of settings within that submenu.

The BIOS setup utility uses a key-based navigation system called hot keys. Most of these hot keys (<F1>, <F4>, <Enter>, <ESC>, <Arrow> keys, etc.) can be used at any time during the setup navigation process.



**Note 1:** Options printed in **Bold** are default settings.

**Note 2:** <F3> is used to load optimal default settings. <F4> is used to save the settings and exit the setup utility.

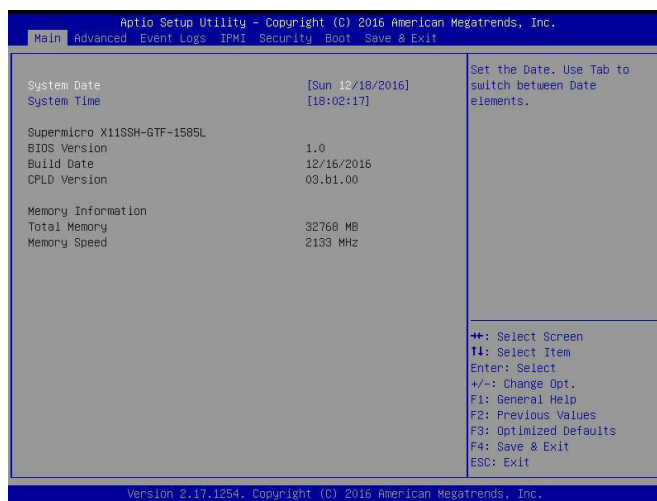
## How To Change the Configuration Data

The configuration data that determines the system parameters may be changed by entering the AMI BIOS setup utility. This setup utility can be accessed by pressing <Delete> at the appropriate time during system boot.

 **Note:** For AMI UEFI BIOS Recovery, please refer to the UEFI BIOS Recovery User Guide posted at <http://www.supermicro.com/support/manuals/>.


## 4.2 Main Setup

When you first enter the AMI BIOS setup utility, you will enter the Main setup screen. You can always return to the Main setup screen by selecting the Main tab on the top of the screen. The Main BIOS setup screen is shown below. The following Main menu items will display:



### System Date/System Time

Use this option to change the system date and time. Highlight *System Date* or *System Time* using the arrow keys. Enter new values using the keyboard. Press the <Tab> key or the arrow keys to move between fields. The date must be entered in Day MM/DD/YYYY format. The time is entered in HH:MM:SS format.

 **Note:** The time is in the 24-hour format. For example, 5:30 P.M. appears as 17:30:00. The date's default value is 01/01/2014 after RTC reset.

### Supermicro X11SSH-GTF-1585L

#### BIOS Version

This item displays the version of the BIOS ROM used in the system.

**Build Date**

This item displays the date when the version of the BIOS ROM used in the system was built.

**CPLD Version**

This item displays the version of the complex programmable logic device (CPLD) utility used in the system.

**Memory Information**

**Total Memory**

This item displays the total size of memory available in the system.

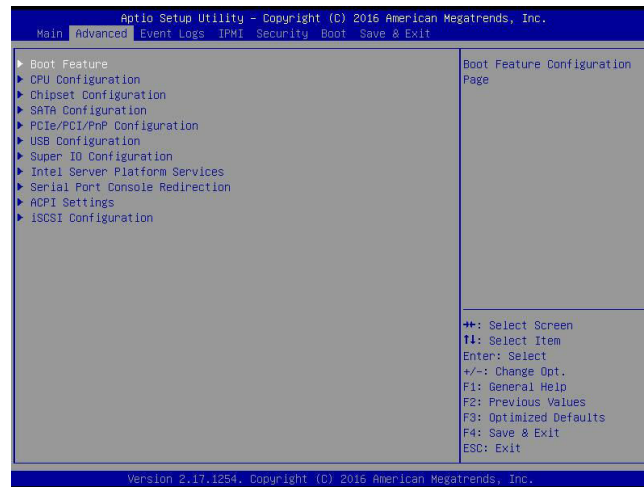
**Memory Speed**

This item displays the speed of memory modules used in the system.



## 4.3 Advanced Setup Configurations

Use the arrow keys to select Boot Setup and press <Enter> to access the submenu items.



**Warning:** Take caution when changing the Advanced settings. An incorrect value, an inaccurate DRAM frequency, or a wrong DRAM timing setting may make the system unstable. When this occurs, revert the setting to the manufacture default settings.

### ► Boot Feature

#### Quiet Boot

Use this feature to select the screen display between the POST messages and the OEM logo upon bootup. Select Disabled to display the POST messages. Select Enabled to display the OEM logo instead of the normal POST messages. The options are Disabled and **Enabled**.

#### AddOn ROM Display Mode

Use this feature to set the display mode for the Option ROM. Select Keep Current to display the current AddOn ROM setting. Select Force BIOS to use the Option ROM display set by the system BIOS. The options are **Force BIOS** and Keep Current.

#### Bootup NumLock State

Use this feature to set the Power-on state for the <Numlock> key. The options are **On** and Off .

#### Wait For 'F1' If Error

Use this feature to force the system to wait until the 'F1' key is pressed if an error occurs. The options are Disabled and **Enabled**.

### **INT19 (Interrupt 19) Trap Response**

Interrupt 19 is the software interrupt that handles the boot disk function. When this item is set to Immediate, the ROM BIOS of the host adaptors will "capture" Interrupt 19 at bootup immediately and allow the drives that are attached to these host adaptors to function as bootable disks. If this item is set to Postponed, the ROM BIOS of the host adaptors will not capture Interrupt 19 immediately and allow the drives attached to these adaptors to function as bootable devices at bootup. The options are **Immediate** and Postponed.

### **Re-try Boot**

If this item is enabled, the BIOS will automatically reboot the system from a specified boot device after its initial boot failure. The options are **Disabled**, Legacy Boot, and EFI Boot.

### **Install Windows 7 USB Support**

Select Enabled to use the USB keyboard and mouse for Windows 7. After the installation of Windows 7 and XHCI driver, please disable this feature inside the BIOS. The options are **Disabled** and Enabled.

## **► Power Configuration**

### **Watch Dog Function**

If enabled, the Watch Dog timer will allow the system to reset or generate NMI based on jumper settings when the system is inactive more than 5 minutes. The options are **Disabled** and Enabled .

### **Power Button Function**

This feature controls how the system shuts down when the power button is pressed. Select 4\_Seconds\_Override for the user to power off the system after pressing and holding the power button for 4 seconds or longer. Select Instant Off to instantly power off the system as soon as the user presses the power button. The options are **Instant Off** and 4 Seconds Override .

### **Restore on AC Power Loss**

Use this feature to set the power state after a power outage. Select Stay-Off for the system power to remain off after a power loss. Select Power-On for the system power to be turned on after a power loss. Select Last State to allow the system to resume its last power state before a power loss. The options are Stay-Off, Power-On, and **Last State**.

## **► CPU Configuration**

The following CPU information will be displayed:

### **CPU Signature**

- Intel® Xeon® CPU E3-1585L v5 @3.00GHz

- CPU Signature
- Microcode Patch
- Max CPU Speed
- Min CPU Speed
- CPU Speed
- Processor Cores
- Hyper Threading Technology
- Intel VT-x Technology
- Intel SMX Technology
- 64-bit
- EIST Technology
- CPU C3 State
- CPU C6 State
- CPU C7 State
- CPU C8 State
- CPU C9 State
- CPU C10 State
- L1 Data Cache
- L1 Code Cache
- L2 Cache
- L3 Cache
- L4 Cache

**Hyper-threading (Available when supported by the CPU)**

Select Enabled to support Intel® Hyper-threading Technology to enhance CPU performance. The options are Disabled and **Enabled** .

### Active Processor Cores

This feature determines how many CPU cores will be activated for each CPU. When all is selected, all cores in the CPU will be activated. (Please refer to Intel's website for more information.) The options are **All** 1,2, and 3.

### Execute Disable Bit (Available if supported by the OS & the CPU)

Set to Enabled for Execute Disable Bit support which will allow the processor to designate areas in the system memory where an application code can execute and where it cannot, thus preventing a worm or a virus from flooding illegal codes to overwhelm the processor or damaging the system during a virus attack. The options are Disabled and **Enabled**. (Refer to Intel and Microsoft websites for more information.)

### Intel® Virtualization Technology

Select Enable to use Intel® Virtualization Technology so that I/O device assignments will be reported directly to the VMM (Virtual Memory Management) through the DMAR ACPI tables. This feature offers fully-protected I/O resource-sharing across the Intel® platforms, providing the user with greater reliability, security and availability in networking and data-sharing. The settings are Disabled and **Enabled**.

### Hardware Prefetcher (Available when supported by the CPU)

If set to Enabled, the hardware prefetcher will prefetch streams of data and instructions from the main memory to the L2 cache to improve CPU performance. The options are Disabled and **Enabled**.

### Adjacent Cache Line Prefetch (Available when supported by the CPU)

Select Disabled for the CPU prefetcher to prefetch the cache line for 64 bytes. Select Enabled for the CPU prefetcher to prefetch both cache lines for 128 bytes as comprised. The options are Disabled and **Enabled**.



**Note:** If there is any change to this setting, you will need to power off and reboot the system for the change to take effect. Please refer to Intel's website for detailed information.

### CPU AES

Select Enabled to enable Intel® CPU Advanced Encryption Standard (AES) Instructions for CPU to enhance data integrity. The options are Disabled and **Enabled**.

### Boot Performance Mode

This feature allows the user to select the performance state that the BIOS will set before the operating system handoff. The options are Power Saving, **Max Non-Turbo Performance** and Turbo Performance.

**HardWare P-States (HWP)**

Use this feature to enable or disable hardware P-States support. The options are **Disabled** and **Enabled**.

**Intel® SpeedStep™**

Intel® SpeedStep Technology allows the system to automatically adjust processor voltage and core frequency to reduce power consumption and heat dissipation. The options are **Disabled** and **Enabled**.

**Turbo Mode**

Select **Enabled** for processor cores to run faster than the frequency specified by the manufacturer. The options are **Disabled** and **Enabled**.

**Package Power Limit MSR Lock**

Select **Enabled** to lock the package power limit for the model-specific registers. The options are **Disabled** and **Enabled**.

**Power Limit 1 Override**

Select **Enabled** to support average power limit (PL1) override. The default setting is **Disabled**.

**Power Limit 2 Override**

Select **Enabled** to support rapid power limit (PL2) override. The default setting is **Enabled**.

**Power Limit 2**

Use this item to configure the value for Power Limit 2. The value is in milli watts and the step size is 125mW. Use the number keys on your keyboard to enter the value. Enter 0 to use the manufacture default setting. If the value is 0, the BIOS will set PL2 as 1.25\* TDP. Enter **0** to use the manufacture default setting.

**1-Core Ratio Limit Override**

This increases (multiplies) 1 clock speed in the CPU core in relation to the bus speed when one CPU core is active. Press "+" or "-" on your keyboard to change the value. Enter **0** to use the manufacture default setting.

**2-Core Ratio Limit Override**

This increases (multiplies) 2 clock speeds in the CPU core in relation to the bus speed when two CPU cores are active. Press "+" or "-" on your keyboard to change the value. Enter **0** to use the manufacture default setting.

### **3-Core Ratio Limit Override**

This increases (multiplies) 3 clock speeds in the CPU core in relation to the bus speed when three CPU cores are active. Press "+" or "-" on your keyboard to change the value. Enter **0** to use the manufacture default setting.

### **4-Core Ratio Limit Override**

This increases (multiplies) 4 clock speeds in the CPU core in relation to the bus speed when three CPU cores are active. Press "+" or "-" on your keyboard to change the value. Enter **0** to use the manufacture default setting.

## **CPU C-States**

Use this feature to enable the C-State of the CPU. The options are Disabled and **Enabled**.

### **Enhanced C-States**

Use this feature to enable the enhanced C-State of the CPU. The options are Disabled and **Enabled**.

### **C-State Auto Demotion**

Use this feature to prevent unnecessary excursions into the C-states to improve latency. The options are Disabled, C1, C3, and **C1 and C3**.

### **C-State Un-Demotion**

This feature allows the user to enable or disable the un-demotion of C-State. The options are Disabled, C1, C3, and **C1 and C3**.

### **Package C-State Demotion**

Use this feature to enable or disable the Package C-State demotion. The options are **Disabled** and Enabled.

### **Package C-State Un-Demotion**

Use this feature to enable or disable the Package C-State un-demotion. The options are **Disabled** and Enabled.

### **C-State Pre-Wake**

This feature allows the user to enable or disable the C-State Pre-Wake. The options are Disabled and **Enabled**.

### **Package C-State Limit**

Use this feature to set the Package C-State limit. The options are C0/C1, C2, C3, C6, C7, C7s, C8, C9, C10 and **Auto**.

## ► CPU Thermal Configuration

### CPU DTS

Select Enabled for the ACPI thermal management to use the DTS SMM mechanism to obtain CPU temperature values. Select Disabled for EC to report the CPU temperature values. The options are **Disabled** and Enabled.

### ACPI 3.0 T-States

Select Enabled to support CPU throttling by the operating system to reduce power consumption. The options are **Disabled** and Enabled .

## ► Chipset Configuration

**Warning:** Setting the wrong values in the following features may cause the system to malfunction.

## ► System Agent (SA) Configuration

The following System Agent information will be displayed:

- System Agent Bridge Name
- SA PCIe Code Version
- VT-d

### VT-d

Select Enabled to enable Intel® Virtualization Technology support for Direct I/O VT-d by reporting the I/O device assignments to VMM through the DMAR ACPI tables. This feature offers fully-protected I/O resource-sharing across the Intel platforms, providing the user with greater reliability, security and availability in networking and data-sharing. The options are Disabled and **Enabled** .

## ► Graphics Configuration

### Primary Display

Use this feature to select the graphics device to be used as the primary display. The options are **Auto**, PEG, and PCIE.

### Primary PEG (PCI-Express Graphics)

This feature allows the user to specify which graphics card to be used as the primary graphics card. The options are **CPU SLOT5 PCI-E 3.0 X8** and CPU SLOT6 PCI-E 3.0 X8 (IN X16).

### Primary PCIE (PCI-Express Graphics)

This feature allows the user to specify which graphics card to be used as the primary graphics card. The options are **Onboard** and PCH SLOT4 PCI-E 3.0 X4 (IN X8).

### Internal Graphics

Select Auto to keep an internal graphics device installed on an expansion slot supported by the CPU to be automatically enabled. The options are Auto, Disabled, and **Enabled**.

### GTT Size

Use this feature to set the memory size to be used by the graphics translation table (GTT). The options are 2MB, 4MB, and **8MB**.

### Aperture Size

Use this feature to set the Aperture size, which is the size of system memory reserved by the BIOS for graphics device use. The options are 128MB, **256MB**, 512MB, 1024MB, 2048MB, and 4096MB.

### DVMT Pre-Allocated

Dynamic Video Memory Technology (DVMT) allows dynamic allocation of system memory to be used for video devices to ensure best use of available system memory based on the DVMT 5.0 platform. The options are **32M**, 64M, 4M, 8M, 12M, 16M, 20M, 24M, 28M, 32M/F7, 36M, 40M, 44M, 48M, 52M, 56M, and 60M.

### DVMT Total IGFX Memory

Use this feature to set the total memory size to be used by internal graphics devices based on the DVMT 5.0 platform. The options are 128MB, **256MB**, and MAX.

### IGFX (Graphics) Low Power Mode

Select Enabled to use the low power mode for internal graphics devices installed in a small form factor (SFF) computer. The options are **Enabled** and Disabled.

### PM Support

Use this item to enable the IGFX Power Management function. The options are **Enabled** and Disabled.

### PAVP Enable

Use this feature to enable or disable the protected audio video path (PAVP). The options are **Enabled** and Disabled.



## ► DMI/OPI Configuration

The following DMI information will be displayed:

- DMI

### **DMI VC1 Control**

Use this feature to enable or disable DMI Virtual Channel 1. The options are Enabled and **Disabled**.

### **DMI VCm Control**

Use this feature to enable or disable the DMI Virtual Channel map. The options are **Enabled** and Disabled.

### **CPU DMI Link ASPM Control**

Use this feature to set the ASPM (Active State Power Management) state on the SA (System Agent) side of the DMI Link. The options are Disabled and **L1**.

### **DMI Extended Sync Control**

Use this feature to enable or disable the DMI extended synchronization. The options are Enabled and **Disabled**.

### **DMI De-Emphasis Control**

Use this feature to configure the De-emphasis control on DMI. The options are -6 dB and **-3.5 dB**.

## ► PEG Port Configuration

### **CPU SLOT5 PCI-E 3.0 X8**

#### **SLOT5 Max Link Speed**

Use this item to configure the link speed of a PCI-E port specified by the user. The options are **Auto**, Gen1, Gen2, and Gen3.

#### **SLOT5 Max Payload Size**

Select Auto for the system BIOS to automatically set the maximum payload value for a PCI-E device to enhance system performance. The options are **Auto**, 128 TLP, and 256 TLP.

#### **SLOT5 ASPM Support**

Use this item to set the Active State Power Management (ASPM) level for a PCI-E device. Select Auto for the system BIOS to automatically set the ASPM level based on the system configuration. Select Disabled to disable ASPM support. The options are Disabled, **Auto**, ASPM L0s, ASPM L1, and ASPM L0s & L1.

### **SLOT5 Power Limit Value**

Use this feature to set the upper limit on the power supplied by the PCIE slot. Press "+" or "-" on your keyboard to change this value. The default setting is **75**.

### **SLOT5 Power Limit Scale**

Use this feature to select the scale used for the slot power limit value. The options are **1.0x**, 0.1x, 0.01x, and 0.001x.

## **CPU SLOT6 PCI-E 3.0 X8 (IN x16)**

### **SLOT6 Max Link Speed**

This feature allows the user to select PCI-E support for the device installed on SLOT6. The options are **Auto**, Gen 1, Gen 2, and Gen 3.

### **SLOT6 Max Payload Size**

Use this feature to select the PEG0 maximum payload size. The options are **Auto**, 128 TLP, and 256 TLP.

### **SLOT6 ASPM Support**

Use this item to set the Active State Power Management (ASPM) level for a PCI-E device. Select Auto for the system BIOS to automatically set the ASPM level based on the system configuration. Select Disabled to disable ASPM support. The options are Disabled, **Auto**, ASPM L0s, ASPM L1, and ASPM L0s & L1.

### **SLOT6 Power Limit Value**

Use this feature to set the upper limit on the power supplied by the PCIE slot. Press "+" or "-" on your keyboard to change this value. The default setting is **75**.

### **SLOT6 Power Limit Scale**

Use this feature to select the scale used for the slot power limit value. The options are **1.0x**, 0.1x, 0.01x, and 0.001x.

## **Program PCIe ASPM After OPROM**

PCIe ASPM, the Active State Power Management for PCI-Express slots, is a power management protocol used to manage power consumption of serial-link devices installed on PCI-Exp slots during a prolonged off-peak time. If this item is set to Enabled, PCI-E ASMP will be programmed after OPROM. If this item is set to Disabled, the PCI-E ASPM will be programmed before OPROM. The options are **Disabled** and Enabled.

## ► Memory Configuration

The following memory information will be displayed:

- Memory RC Version
- Memory Frequency
- Total Memory
- VDD
- DIMMA1
- DIMMA2
- DIMMB1
- DIMMB2
- Memory Timings (tCL-tRCD-tRP-tRAS)

### Maximum Memory Frequency

Use this feature to set the maximum memory frequency for onboard memory modules. The options are **Auto**, 1067, 1200, 1333, 1400, 1600, 1800, 1867, 2000, 2133, 2200, 2400, 2600, 2667, 2800, 2933, 3000, and 3200.

### Max TOLUD

This feature sets the maximum TOLUD value, which specifies the "Top of Low Usable DRAM" memory space to be used by internal graphics devices, GTT Stolen Memory, and TSEG, respectively, if these devices are enabled. The options are **Dynamic**, 1 GB, 1.25 GB, 1.5 GB, 1.75 GB, 2 GB, 2.25 GB, 2.5 GB, 2.75 GB, 3 GB, 3.25 GB, and 3.5 GB.

### Energy Performance Gain

Use this feature to enable or disable the energy performance gain. The options are **Disabled** and **Enabled**.

### Memory Scrambler

Select **Enabled** to enable memory scrambler support. The options are **Disabled** and **Enabled**.

### Fast Boot

Use this feature to enable or disable fast path through the memory reference code. The options are **Enabled** and **Disabled**.

## **REFRESH\_2X\_MODE**

Use this feature to select the refresh mode. The options are **Disabled**, 1-Enabled for WARM or HOT, and 2-Enabled HOT only.

## **Closed Loop Thermal Throttling Management**

Select Enabled to support Closed-Loop Thermal Throttling which will improve reliability and reduces CPU power consumption via automatic voltage control while the CPU are in idle states. The options are Disabled and **Enabled**.

## **►GT - Power Management Control**

The following GT - Power Management Control information will be displayed:

- GT Info

## **RC6 (Render Standby)**

Select Enabled to enable render standby support. The options are Disabled and **Enabled**.

## **►PCH-IO Configuration**

The following PCH-IO information will be displayed:

- Intel PCH RC Version
- Intel PCH SKU Name
- Intel PCH Rev ID

## **►PCI Express Configuration**

### **PCH DMI Link ASPM Control**

Use this feature to set the ASPM (Active State Power Management) state on the SA (System Agent) side of the DMI Link. The options are Disabled and **Enabled**.

### **Peer Memory Write Enable**

Use this feature to enable or disable peer memory write. The options are **Disabled** or Enabled.

## ► PCH SLOT4 PCI-E 3.0 X4 (IN X8)

### SLOT4 ASPM

Use this item to set the Active State Power Management (ASPM) level for the PCI-E device installed on the slot specified. Select Auto for the system BIOS to automatically set the ASPM level based on the system configuration. Select Disabled to disable ASPM support. The options are Disabled, L0s, L1, L0s & L1, and **Auto**.

### SLOT4 L1 Substates

Use this feature to configure the PCI Express L1 substates. The options are Disabled, L1.1, L1.2, and **L1.1 & L1.2**

### SLOT4 PCIe Speed

Use this feature to select the PCI Express port speed. The options are **Auto**, Gen1, Gen2, and Gen3.

### SLOT4 Detect Non-Compliance

Select Enabled for the AMI BIOS to automatically detect a PCI-E device that is not compliant with the PCI-E standards. The options are **Disabled** and Enabled.

## ► PCI-E 3.0 M.2

### PCI-E 3.0 M.2 ASPM Support

Use this item to set the Active State Power Management (ASPM) level for the PCI-E 3.0 M.2 device installed on the slot specified. Select Auto for the system BIOS to automatically set the ASPM level based on the system configuration. Select Disabled to disable ASPM support. The options are Disabled, L0s, L1, L0s & L1, and **Auto**.

### PCI-E 3.0 M.2 L1 Substates

Use this feature to configure the PCI Express L1 substates. The options are Disabled, L1.1, L1.2, and **L1.1 & L1.2**

### PCI-E 3.0 M.2 PCIe Speed

Use this feature to select the PCI Express port speed. The options are **Auto**, Gen1, Gen2, and Gen3.

### PCI-E 3.0 M.2 Detect Non-Compliance Dev

Select Enabled for the AMI BIOS to automatically detect a PCI-E device that is not compliant with the PCI-E standards. The options are **Disabled** and Enabled.

**Port 61h bit-4 Emulation**

Select Enabled to enable the emulation of Port 61h bit-4 toggling in SMM (System Management Mode). The options are Disabled and **Enabled**.

**PCIe PLL SSC**

Select Enabled to enable Phase Locked Loop (PLL) support on the Spread Spectrum Clock (SSC) settings to help reduce Electromagnetic Interference caused by the components in the system. Select Disabled to enhance system stability. The options are **Disabled** and Enabled

**►SATA Configuration**

When this submenu is selected, the AMI BIOS automatically detects the presence of the SATA devices that are supported by the Intel® PCH chip and displays the following items:

**SATA Controller(s)**

This item enables or disables the onboard SATA controller supported by the Intel® PCH chip. The options are **Enabled** and Disabled.

**SATA Mode Selection**

Use this item to select the mode for the installed SATA drives. The options are **AHCI** and RAID.

**SATA Frozen**

Use this item to enable the HDD Security Frozen Mode. The options are **Disabled** and Enabled.

**Aggressive LPM Support**

When this item is set to Enabled, the SATA AHCI controller manages the power usage of the SATA link. The controller will put the link in a low power mode during extended periods of I/O inactivity, and will return the link to an active state when an I/O activity resumes. The options are Enabled and **Disabled**.

**Serial ATA Port 0 ~ Port 7**

This item displays the information detected on the installed SATA drive on the particular SATA port.

- Model number of drive and capacity
- Software Preserve Support

**Port 0 ~ Port 7 Hot Plug**

This feature designates the SATA port specified for hot plugging. Set this item to Enabled for hot-plugging support, which will allow the user to replace a SATA disk drive without shutting down the system. The options are **Disabled** and Enabled.

**Port 0 ~ Port 7 Spin Up Device**

On an edge detect from 0 to 1, set this item to allow the PCH to initialize the device. The options are Enabled and **Disabled**.

**Port 0 ~ Port 7 SATA Device Type**

Use this item to specify if the SATA port specified by the user should be connected to a Solid State drive or a Hard Disk Drive. The options are **Hard Disk Drive** and Solid State Drive.

**►PCIe/PCI/PnP Configuration**

The following information will be displayed:

- PCI Bus Driver Version
- PCI Devices Common Settings:

**PCI PERR/SERR Support**

Select Enabled to support PERR (PCI/PCI-E Parity Error)/SERR (System Error) runtime error reporting for a PCI/PCI-E slot. The options are **Disabled** and Enabled.

**Above 4G Decoding (Available if the system supports 64-bit PCI decoding)**

Select Enabled to decode a PCI device that supports 64-bit in the space above 4G Address. The options are **Disabled** and Enabled.

**SR-IOV Support**

Use this feature to enable or disable Single Root IO Virtualization Support. The options are **Disabled** and Enabled.

**PCH SLOT4 PCI-E 3.0 X4 (IN X8) OPROM**

Use this feature to select which firmware type to be loaded for the add-on card in this slot for system boot. The options are Disabled, **Legacy**, and EFI.

**CPU SLOT5 PCI-E 3.0 X8 OPROM**

Use this feature to select which firmware type to be loaded for the add-on card in this slot for system boot. The options are Disabled, **Legacy**, and EFI.

**CPU SLOT6 PCI-E 3.0 X8 (IN X16) OPROM**

Use this feature to select which firmware type to be loaded for the add-on card in this slot for system boot. The options are Disabled, **Legacy**, and EFI.

**Onboard LAN Option ROM Type**

Select Enabled to enable Option ROM support to boot the computer using a network device specified by the user. The options are **Legacy** and EFI.

**Onboard LAN1 Option ROM**

Use this option to select the type of device installed in LAN Port1 used for system boot. The default setting for this item is **Enabled**.

**Onboard LAN2 Option ROM**

Use this option to select the type of device installed in a LAN port specified by user for system boot. The default setting for this item is **Disabled**.

**Onboard Video Option ROM**

Use this item to select the Onboard Video Option ROM type. The options are Disabled, **Legacy**, and EFI.

**Network Stack**

Select Enabled to enable PXE (Preboot Execution Environment) or UEFI (Unified Extensible Firmware Interface) for network stack support. The options are Disabled and **Enabled**.

**IPv4 PXE Support**

Select Enabled to enable IPv4 PXE boot support. The options are Disabled and **Enabled**.

**IPv6 PXE Support**

Select Enabled to enable IPv6 PXE boot support. The options are **Disabled** and Enabled.

**PXE boot wait time**

Use this option to specify the wait time to press the ESC key to abort the PXE boot. Press "+" or "-" on your keyboard to change the value. The default setting is **0**.

**Media detect count**

Use this option to specify the number of times media will be checked. Press "+" or "-" on your keyboard to change the value. The default setting is **1**.

**►USB Configuration**

The following USB items will display.

- USB Module Version
- USB Controllers
- USB Devices

**Legacy USB Support (Available when USB Functions is not Disabled)**

Select Enabled to support legacy USB devices. Select Auto to disable legacy support if USB devices are not present. Select Disabled to have USB devices available for EFI (Extensive Firmware Interface) applications only. The settings are **Enabled**, Disabled, and Auto.



### **XHCI Hand-Off**

This item is for operating systems that do not support eXtensible Host Controller Interface (XHCI) hand-off. When this item is enabled, XHCI ownership change will be claimed by the XHCI driver. The settings are **Enabled** and Disabled.

### **Port 60/64 Emulation**

Select Enabled for I/O port 60h/64h emulation support which will provide complete USB keyboard legacy support for the operating system that does not support Legacy USB devices. The options are Disabled and **Enabled**.

## **► Super IO Configuration**

The following Super IO information will be displayed:

- Super IO Chip

### **► Serial Port 1**

This submenu allows the user the configure settings of Serial Port 1.

#### **Serial Port 1**

Select Enabled to enable the selected onboard serial port. The options are Disabled and **Enabled**.

#### **Device Settings**

This item displays the current status of a serial part specified by the user.

#### **Serial Port 1 Change Settings**

This feature specifies the base I/O port address and the Interrupt Request address of a serial port specified by the user. Select Auto to allow the BIOS to automatically assign the base I/O and IRQ address.

The options for Serial Port 1 are **Auto**, (IO=3F8h; IRQ=4), (IO=3F8h; IRQ=3, 4, 5, 6, 7, 9, 10, 11, 12), (IO=2F8h; IRQ=3, 4, 5, 6, 7, 9, 10, 11, 12), (IO=3E8h; IRQ=3, 4, 5, 6, 7, 9, 10, 11, 12), and (IO=2E8h; IRQ=3, 4, 5, 6, 7, 9, 10, 11, 12).

### **► Serial Port 2**

This submenu allows the user the configure settings of Serial Port 2.

#### **Serial Port 2**

Select Enabled to enable the selected onboard serial port. The options are Disabled and **Enabled**.

#### **Device Settings**

This item displays the current status of a serial part specified by the user.

### Serial Port 2 Change Settings

This feature specifies the base I/O port address and the Interrupt Request address of a serial port specified by the user. Select Auto to allow the BIOS to automatically assign the base I/O and IRQ address.

The options for Serial Port 2 are **Auto**, (IO=2F8h; IRQ=3), (IO=3F8h; IRQ=3, 4, 5, 6, 7, 9, 10, 11, 12), (IO=2F8h; IRQ=3, 4, 5, 6, 7, 9, 10, 11, 12), (IO=3E8h; IRQ=3, 4, 5, 6, 7, 9, 10, 11, 12), and (IO=2E8h; IRQ=3, 4, 5, 6, 7, 9, 10, 11, 12).

### Serial Port 2 Attribute

Select SOL to use COM Port 2 as a Serial\_Over\_LAN (SOL) port for console redirection. The options are **SOL** and COM.

## ► Intel Server Platform Services

Intel Server Platform Services Configuration

The following items will display as detected by the BIOS:

- ME BIOS Interface Version
- SPS Version
- ME FW (Firmware) Status Value
- ME FW (Firmware) State
- ME FW (Firmware) Operation State
- ME FW (Firmware) Error Code
- ME NM FW (Firmware) Status Value
- BIOS Booting Mode
- Cores Disabled
- ME FW (Firmware) SKU Information
- End-of POST Status

## ► Serial Port Console Redirection

### COM1

#### COM1 Console Redirection

Select Enabled to enable console redirection support for a serial port specified by the user. The options are **Disabled** and Enabled. If this feature is set to Enabled, the following items will become available:

#### ► COM1 Console Redirection Settings

This feature allows the user to specify how the host computer will exchange data with the client computer, which is the remote computer used by the user.

#### COM1 Terminal Type

This feature allows the user to select the target terminal emulation type for Console Redirection. Select VT100 to use the ASCII Character set. Select VT100+ to add color and function key support. Select ANSI to use the Extended ASCII Character Set. Select VT-UTF8 to use UTF8 encoding to map Unicode characters into one or more bytes. The options are VT100, **VT100+**, VT-UTF8, and ANSI.

#### COM1 Bits Per second

Use this feature to set the transmission speed for a serial port used in Console Redirection. Make sure that the same speed is used in the host computer and the client computer. A lower transmission speed may be required for long and busy lines. The options are 9600, 19200, 38400, 57600, and **115200** (bits per second).

#### COM1 Data Bits

Use this feature to set the data transmission size for Console Redirection. The options are 7 Bits and **8 Bits**.

#### COM1 Parity

A parity bit can be sent along with regular data bits to detect data transmission errors. Select Even if the parity bit is set to 0, and the number of 1's in data bits is even. Select Odd if the parity bit is set to 0, and the number of 1's in data bits is odd. Select None if you do not want to send a parity bit with your data bits in transmission. Select Mark to add a mark as a parity bit to be sent along with the data bits. Select Space to add a Space as a parity bit to be sent with your data bits. The options are **None**, Even, Odd, Mark and Space.

#### COM1 Stop Bits

A stop bit indicates the end of a serial data packet. Select 1 Stop Bit for standard serial data communication. Select 2 Stop Bits if slower devices are used. The options are **1** and 2.

### **COM1 Flow Control**

Use this feature to set the flow control for Console Redirection to prevent data loss caused by the overflow of the buffer. Send a "Stop" signal to stop sending data when the receiving buffer is full. Send a "Start" signal to start sending data when the receiving buffer is empty. The options are **None** and Hardware RTS/CTS.

### **COM1 VT-UTF8 Combo Key Support**

Select Enabled to enable VT-UTF8 Combination Key support for ANSI/VT100 terminals. The options are Disabled and **Enabled**.

### **COM1 Recorder Mode**

Select Enabled to capture the data displayed on a terminal and send it as text messages to a remote server. The options are **Disabled** and Enabled.

### **COM1 Resolution 100x31**

Select Enabled for extended-terminal resolution support. The options are Disabled and **Enabled**.

### **COM1 Legacy OS Redirection Resolution**

Use this feature to select the number of rows and columns used in Console Redirection for legacy OS support. The options are 80x24 and **80x25**.

### **COM1 Putty KeyPad**

This feature selects the settings for Function Keys and KeyPad used for Putty, which is a terminal emulator designed for the Windows OS. The options are **VT100**, LINUX, XTERMR6, SC0, ESCN, and VT400.

### **COM1 Redirection After BIOS Post**

Use this feature to enable or disable legacy console redirection after BIOS POST. When set to Bootloader, legacy console redirection is disabled before booting the OS. When set to Always Enable, legacy console redirection remains enabled when booting the OS. The options are **Always Enable** and BootLoader.

## **SOL/COM2**

### **SOL/COM2 Console Redirection**

Select Enabled to enable Console Redirection support for a serial port specified by the user. The options are Disabled and **Enabled**. If this feature is set to Enabled, the following items will become available:

## ► SOL/COM2 Console Redirection Settings

Use this feature to specify how the host computer will exchange data with the client computer, which is the remote computer used by the user.

### COM2 Terminal Type

Use this feature to select the target terminal emulation type for Console Redirection. Select VT100 to use the ASCII Character set. Select VT100+ to add color and function key support. Select ANSI to use the Extended ASCII Character Set. Select VT-UTF8 to use UTF8 encoding to map Unicode characters into one or more bytes. The options are ANSI, VT100, **VT100+**, VT-UTF8, and ANSI.

### COM2 Bits Per second

Use this feature to set the transmission speed for a serial port used in Console Redirection. Make sure that the same speed is used in the host computer and the client computer. A lower transmission speed may be required for long and busy lines. The options are 9600, 19200, 38400, 57600 and **115200** (bits per second).

### COM2 Data Bits

Use this feature to set the data transmission size for Console Redirection. The options are 7 (Bits) and **8 (Bits)**.

### COM2 Parity

A parity bit can be sent along with regular data bits to detect data transmission errors. Select Even if the parity bit is set to 0, and the number of 1's in data bits is even. Select Odd if the parity bit is set to 0, and the number of 1's in data bits is odd. Select None if you do not want to send a parity bit with your data bits in transmission. Select Mark to add a mark as a parity bit to be sent along with the data bits. Select Space to add a Space as a parity bit to be sent with your data bits. The options are **None**, Even, Odd, Mark and Space.

### COM2 Stop Bits

A stop bit indicates the end of a serial data packet. Select 1 Stop Bit for standard serial data communication. Select 2 Stop Bits if slower devices are used. The options are **1** and 2.

### COM2 Flow Control

Use this feature to set the flow control for Console Redirection to prevent data loss caused by an overflow of the buffer. Send a "Stop" signal to stop sending data when the receiving buffer is full. Send a "Start" signal to start sending data when the receiving buffer is empty. The options are **None** and Hardware RTS/CTS.

### COM2 VT-UTF8 Combo Key Support

Select Enabled to enable VT-UTF8 Combination Key support for ANSI/VT100 terminals. The options are Disabled and **Enabled**.

**COM2 Recorder Mode**

Select Enabled to capture the data displayed on a terminal and send it as text messages to a remote server. The options are **Disabled** and Enabled.

**COM2 Resolution 100x31**

Select Enabled for extended-terminal resolution support. The options are Disabled and **Enabled**.

**COM2 Legacy OS Redirection Resolution**

Use this feature to select the number of rows and columns used in Console Redirection for legacy OS support. The options are 80x24 and **80x25**.

**COM2 Putty KeyPad**

This feature selects Function Keys and KeyPad settings for Putty, which is a terminal emulator designed for the Windows OS. The options are **VT100**, LINUX, XTERMR6, SCO, ESCN, and VT400.

**COM2 Redirection After BIOS Post**

Use this feature to enable or disable legacy Console Redirection after BIOS POST. When set to Bootloader, legacy Console Redirection is disabled before booting the OS. When set to Always Enable, legacy Console Redirection remains enabled when booting the OS. The options are **Always Enable** and BootLoader.

**Serial Port for Out-of-Band Management/Windows Emergency Management Services (EMS)****EMS Console Redirection**

Select Enabled to enable Console Redirection support for a serial port specified by the user. The options are **Disabled** and Enabled. If this feature is set to Enabled, the following items will become available:

**►EMS Console Redirection Settings**

This feature allows the user to specify how the host computer will exchange data with the client computer, which is the remote computer used by the user.

**Out-of-Band Management Port**

The feature selects a serial port in a client server to be used by the Microsoft Windows Emergency Management Services (EMS) to communicate with a remote host server. The options are **COM1**, and SOL/COM2.

**Terminal Type**

Use this feature to select the target terminal emulation type for Console Redirection. Select VT100 to use the ASCII character set. Select VT100+ to add color and function key support. Select ANSI to use the extended ASCII character set. Select VT-UTF8 to use UTF8 encoding to map Unicode characters into one or more bytes. The options are VT100, VT100+, **VT-UTF8**, and ANSI.

**Bits Per Second**

This item sets the transmission speed for a serial port used in Console Redirection. Make sure that the same speed is used in the host computer and the client computer. A lower transmission speed may be required for long and busy lines. The options are 9600, 19200, 57600, and **115200** (bits per second).

**Flow Control**

Use this item to set the flow control for Console Redirection to prevent data loss caused by buffer overflow. Send a "Stop" signal to stop sending data when the receiving buffer is full. Send a "Start" signal to start sending data when the receiving buffer is empty. The options are **None**, Hardware RTS/CTS, and Software Xon/Xoff.

**Data Bits**

Use this feature to set the data transmission size for Console Redirection. The options are 7 (Bits) and **8 (Bits)**.

**Parity**

A parity bit can be sent along with regular data bits to detect data transmission errors. Select Even if the parity bit is set to 0, and the number of 1's in data bits is even. Select Odd if the parity bit is set to 0, and the number of 1's in data bits is odd. Select None if you do not want to send a parity bit with your data bits in transmission. Select Mark to add a mark as a parity bit to be sent along with the data bits. Select Space to add a Space as a parity bit to be sent with your data bits. The options are **None**, Even, Odd, Mark and Space.

**Stop Bits**

A stop bit indicates the end of a serial data packet. Select 1 Stop Bit for standard serial data communication. Select 2 Stop Bits if slower devices are used. The options are **1** and **2**.

## ▶ACPI Settings

### High Precision Event Timer

Select Enabled to activate the High Performance Event Timer (HPET) that produces periodic interrupts at a much higher frequency than a Real-time Clock (RTC) does in synchronizing multimedia streams, providing smooth playback and reducing the dependency on other timestamp calculation devices, such as an x86 RDTSC Instruction embedded in the CPU. The High Performance Event Timer is used to replace the 8254 Programmable Interval Timer. The options are Disabled and **Enabled**.

### WHEA Support

This feature Enables the Windows Hardware Error Architecture (WHEA) support for the Windows 2008 (or a later version) operating system. The options are Disabled and **Enabled**.

## ▶iSCSi Configuration

### iSCSI Initiator Name

This feature allows the user to enter the unique name of the iSCSI Initiator in IQN format. Once the name of the iSCSI Initiator is entered into the system, configure the proper settings for the following items.

### ▶Add an Attempt

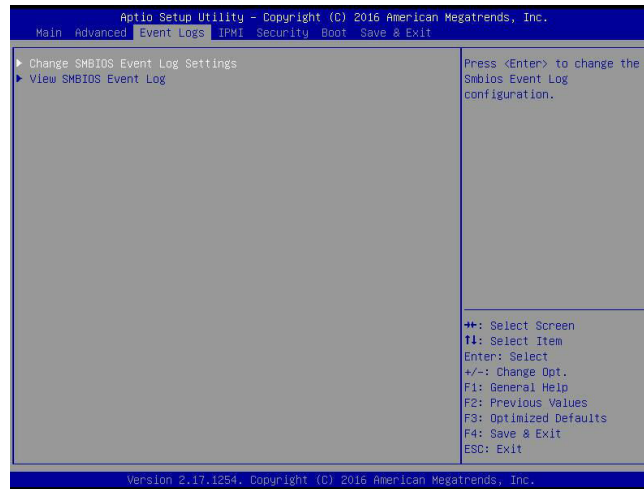
### ▶Delete Attempts

### ▶Change Attempt order



## 4.4 Event Logs

This submenu allows the user to configure Event Log settings.



### ►Change SMBIOS Event Log Settings

This feature allows the user to configure SMBIOS Event settings.

#### Enabling/Disabling Options

##### SMBIOS Event Log

Select Enabled to enable SMBIOS (System Management BIOS) Event Logging during system boot. The options are Disabled and **Enabled**.

#### Erasing Settings

##### Erase Event Log

Select Yes to erase all error events in the SMBIOS (System Management BIOS) log before an event logging is initialized at bootup. The options are **No**, (Yes, Next reset), and (Yes, every reset).

##### When Log is Full

Select Erase Immediately to immediately erase all errors in the SMBIOS event log when the event log is full. Select Do Nothing for the system to do nothing when the SMBIOS event log is full. The options are **Do Nothing** and Erase Immediately.

#### SMBIOS Event Log Standard Settings

##### Log System Boot Event

Select Enabled to log system boot events. The options are Enabled and **Disabled**.

### **MECI (Multiple Event Count Increment)**

Enter the increment value for the multiple event counter. Enter a number between 1 to 255. The default setting is 1.

### **METW (Multiple Event Count Time Window)**

This item is used to determine how long (in minutes) the multiple event counter should wait before generating a new event log. Enter a number between 0 to 99. The default setting is 60.



**Note:** Please reboot the system for the changes to take effect.

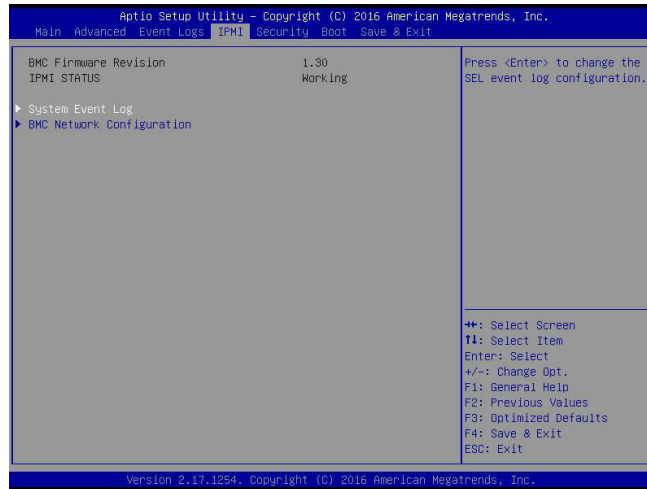
### **►View SMBIOS Event Log**

This item allows the user to view the event in the SMBIOS event log. The following categories are displayed:

**Date/Time/Error Code/Severity**

## 4.5 IPMI

This submenu allows the user to configure Intelligent Platform Management Interface (IPMI) settings.



The following IPMI information will be displayed:

- BMC Firmware Revision
- IPMI STATUS

### ►System Event Log

#### Enabling/Disabling Options

##### SEL Components

Select Enabled to enable all system event logging support at bootup. The options are Disabled and **Enabled**.


##### Erasing Settings

##### Erase SEL

Select Yes, On next reset to erase all system event logs upon next system reboot. Select Yes, On every reset to erase all system event logs upon each system reboot. Select No to keep all system event logs after each system reboot. The options are **No**, (Yes, On next reset), and (Yes, On every reset).

##### When SEL is Full

This feature allows the user to determine what the AMI BIOS should do when the system event log is full. Select Erase Immediately to erase all events in the log when the system event log is full. The options are **Do Nothing** and Erase Immediately.

 **Note:** After making changes on a setting, be sure to reboot the system for the changes to take effect.

## ►BMC Network Configuration

The following items will be displayed:

- IPMI LAN Selection
- IPMI Network Link Status

### Update IPMI LAN Configuration

Select Yes for the system BIOS to automatically reset the following IPMI settings upon next system boot. The options are **No** and Yes.

### Configuration Address Source (Available when the item above - Update IPMI LAN Configuration is set to Yes)

Use this item to select the IP address source for this computer. If Static is selected, you will need to know the IP address of this computer and enter it to the system manually in the field. If DHCP is selected, AMI BIOS will search for a DHCP (Dynamic Host Configuration Protocol) server attached to the network and request the next available IP address for this computer. The options are **DHCP** and Static.

### Station IP Address

This item displays the Station IP address for this computer. This should be in decimal and in dotted quad form (i.e., 192.168.10.253).

### Subnet Mask

This item displays the sub-network that this computer belongs to. The value of each three-digit number is separated by dots and it should not exceed 255.

### Station MAC Address

This item displays the Station MAC address for this computer. Mac addresses are 6 two-digit hexadecimal numbers.

### Gateway IP Address

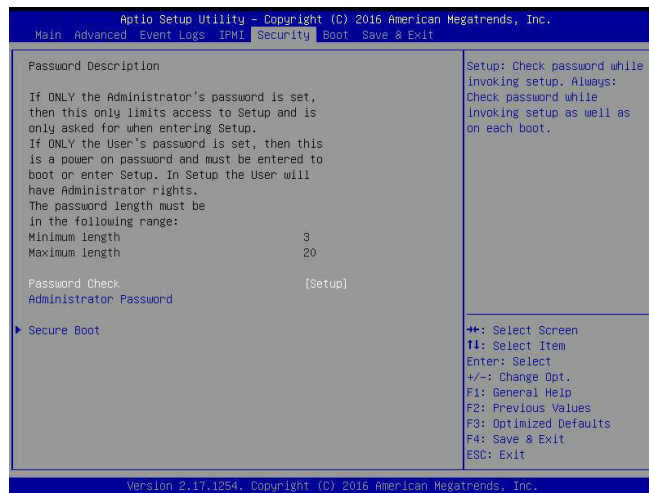
This item displays the Gateway IP address for this computer. This should be in decimal and in dotted quad form (i.e., 172.31.0.1).

### VLAN

Use this item to enable or disable the IPMI VLAN function. The default setting is **Disable**.

## 4.6 Security

This menu allows the user to configure the following security settings for the system.



### Password Check

Select Setup for the system to check for a password at Setup. Select Always for the system to check for a password at bootup or upon entering the BIOS Setup utility. The options are **Setup** and **Always**.

### Administrator Password

Press Enter to create a new, or change an existing Administrator password.

### ► Secure Boot Menu

This section displays the contents of the following secure boot features:

- System Mode
- Secure Boot
- Vendor Keys

### Secure Boot control

Use this item to enable secure boot. The options are **Disabled** and **Enabled**.

### Secure Boot Mode

Use this item to select the secure boot mode. The options are **Standard** and **Custom**.

### CSM Support

Select Enabled to support the EFI Compatibility Support Module (CSM), which provides compatibility support for traditional legacy BIOS for system boot. The options are **Disabled** and **Enabled**.

## ▶ **Key Management**

This submenu allows the user to configure the following Key Management settings.

*\*If the item above -"Secure Boot Mode" is set to Custom, the following items will be displayed:*

### **Provision Factory Default Keys (Available when the system is in Setup Mode)**

Select Enabled to install factory default secure-boot keys. The options are Enabled and Disabled.

## ▶ **Enroll All Factory Default Keys**

This feature allows the user to store security-related boot data in a file of the same named in the system root folder of your computer.

## ▶ **Save All Secure Boot Variables**

This feature allows the user to save the secure boot settings specified by the user.

**Secure Boot Variables: Size/Key#/Key Source**

### ▶ **Platform Key (PK): Size/Key#/Key Source**

### ▶ **Key Exchange Keys: Size/Key#/Key Source**

### ▶ **Authorized Signatures: Size/Key#/Key Source**

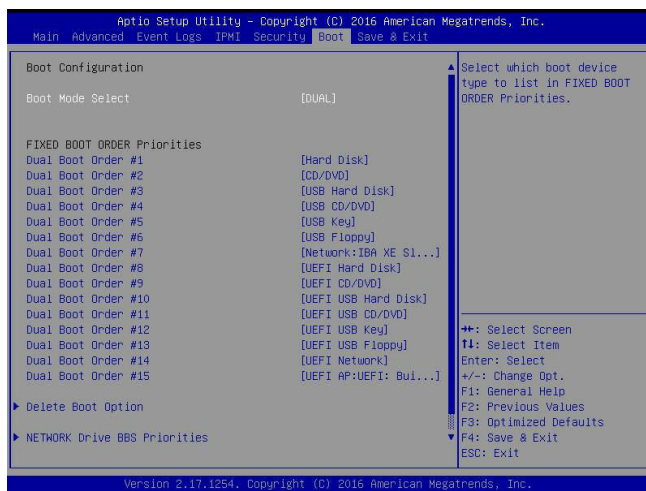
### ▶ **Forbidden Signatures: Size/Key#/Key Source**

### ▶ **Authorized TimeStamps: Size/Key#/Key Source**

### ▶ **OsRecovery Signatures: Size/Key#/Key Source**

## 4.7 Boot Settings

This submenu allows the user to configure Boot settings for this system:



### Boot Configuration

#### Boot Mode Select

Use this item to select the type of device to be used for system boot. The options are Legacy, UEFI, and **Dual**.

#### FIXED BOOT ORDER Priorities

This option prioritizes the order of bootable devices from which the system will boot. Press <Enter> on each entry from top to bottom to select devices.

***\*If the item above -"Boot Mode Select" is set to Dual (default), the following items will be displayed:***

- Dual Boot Order #1 - Dual Boot Order #15

***\*If the item above -"Boot Mode Select" is set to Legacy, the following items will be displayed:***

- Legacy Boot Order #1 - Legacy Boot Order #7

***\*If the item above -"Boot Mode Select" is set to UEFI, the following items will be displayed:***

- UEFI Boot Order #1 - UEFI Boot Order #8

### ▶ Delete Boot Option

Use this item to select a boot device to delete from the boot priority list.

#### Delete Boot Option

Select the target boot device to delete from the boot priority list.

*\*If devices are detected by the system, the following items will be displayed. The default options list devices that have been connected to your system.*

### ▶ Hard Disk Drive BBS Priorities

- Legacy Boot Order #1 - This feature sets the system boot order of detected devices. The options are **(P4: WDC WD3000FYYZ-01UL1B0)** and Disabled.

### ▶ Network Drive BBS Priorities

- Legacy Boot Order #1 - This feature sets the system boot order of detected devices. The options are **(IBA XE Slot 0200 v2358)** and Disabled.

### ▶ USB Key Drive BBS Priorities

- Legacy Boot Order #1 - This feature sets the system boot order of detected devices. The options are **(SMI USB DISK 1100)** and Disabled.

### ▶ UEFI Hard Disk Drive BBS Priorities

- UEFI Boot Order #1 - This feature sets the system boot order of detected devices. The options are **(Windows Boot Manager)** and Disabled.

### ▶ UEFI USB Key Drive BBS Priorities

- UEFI Boot Order #1 - This feature sets the system boot order of detected devices. The options are **(UEFI: SMI USB DISK 1100, Partition 1)** and Disabled.

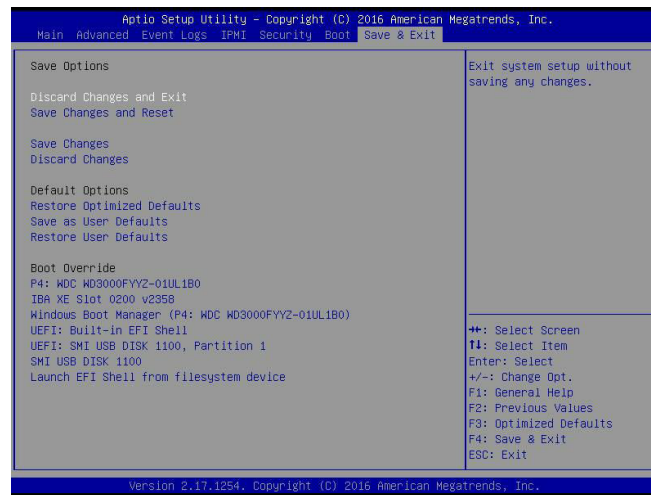
### ▶ UEFI Application Boot Priorities

- UEFI Boot Order #1 - This feature sets the system boot order of detected devices. The options are **(UEFI: Built-in EFI Shell)** and Disabled.



## 4.8 Save & Exit

Select the Exit tab from the BIOS setup utility screen to enter the Exit BIOS Setup screen.



### Save Options

#### Discard Changes and Exit

Select this option to quit the BIOS Setup without making any permanent changes to the system configuration, and reboot the computer. Select Discard Changes and Exit from the Exit menu and press <Enter>.

#### Save Changes and Reset

When you have completed the system configuration changes, select this option to leave the BIOS setup utility and reboot the computer, so the new system configuration parameters can take effect. Select Save Changes and Exit from the Exit menu and press <Enter>.

#### Save Changes

After completing the system configuration changes, select this option to save the changes you have made. This will not reset (reboot) the system.

#### Discard Changes

Select this option and press <Enter> to discard all the changes and return to the AMI BIOS utility Program.

#### Default Options

#### Restore Optimized Defaults

To set this feature, select Restore Optimized Defaults from the Save & Exit menu and press <Enter>. These are factory settings designed for maximum system performance, but not for maximum security.

### **Save as User Defaults**

To set this feature, select Save as User Defaults from the Exit menu and press <Enter>. This enables the user to save any changes to the BIOS setup for future use.

### **Restore User Defaults**

To set this feature, select Restore User Defaults from the Exit menu and press <Enter>. Use this feature to retrieve user-defined settings that were saved previously.

### **Boot Override**

Listed on this section are other boot options for the system (i.e., Built-in EFI shell). Select an option and press <Enter>. Your system will boot to the selected boot option.

# Appendix A

## BIOS Codes

### A.1 BIOS Error POST (Beep) Codes

During the POST (Power-On Self-Test) routines, which are performed each time the system is powered on, errors may occur.

**Non-fatal errors** are those which, in most cases, allow the system to continue with the boot-up process. The error messages normally appear on the screen.

**Fatal errors** are those which will not allow the system to continue to boot. If a fatal error occurs, you should consult with your system manufacturer for possible repairs.

These fatal errors are usually communicated through a series of audible beeps. The numbers on the fatal error list correspond to the number of beeps for the corresponding error. All errors listed, with the exception of Beep Code 8, are fatal errors.

BIOS Beep (POST) Codes		
Beep Code	Error Message	Description
1 beep	Refresh	Circuits have been reset (Ready to power up)
5 short, 1 long	Memory error	No memory detected in system
5 long, 2 short	Display memory read/write error	Video adapter missing or with faulty memory
1 long continuous	System OH	System overheat condition

## A.2 Additional BIOS POST Codes

The AMI BIOS supplies additional checkpoint codes, which are documented online at <http://www.supermicro.com/support/manuals/> ("AMI BIOS POST Codes User's Guide").

When BIOS performs the Power On Self Test, it writes checkpoint codes to I/O port 0080h. If the computer cannot complete the boot process, a diagnostic card can be attached to the computer to read I/O port 0080h (Supermicro p/n AOC-LPC80-20).

For information on AMI updates, please refer to <http://www.ami.com/products/>.

# Appendix B

## Software Installation


### B.1 Installing Software Programs

The Supermicro website contains drivers and utilities for your system at <https://www.supermicro.com/wftp/driver>. Some of these must be installed, such as the chipset driver.

After accessing the website, go into the CDR\_Images (in the parent directory of the above link) and locate the ISO file for your motherboard. Download this file to create a DVD of the drivers and utilities it contains. (You may also use a utility to extract the ISO file if preferred.)

After creating a DVD with the ISO files, insert the disk into the DVD drive on your system and the display shown in Figure B-1 should appear.

Another option is to go to the Supermicro website at <http://www.supermicro.com/products/>. Find the product page for your motherboard here, where you may download individual drivers and utilities to your hard drive or a USB flash drive and install from there.

 **Note:** To install the Windows OS, please refer to the instructions posted on our website at <http://www.supermicro.com/support/manuals/>.

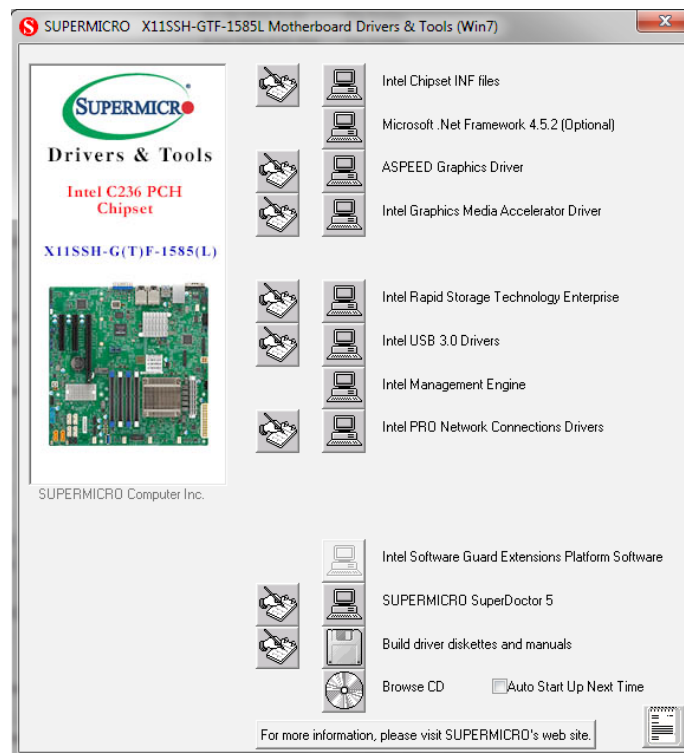


Figure B-1. Driver/Tool Installation Display Screen

Click the icons showing a hand writing on paper to view the readme files for each item. Click the computer icons to the right of these items to install each item (from top to bottom) one at a time. **After installing each item, you must re-boot the system before moving on to the next item on the list.** The bottom icon with a CD on it allows you to view the entire contents.

## B.2 SuperDoctor® 5

The Supermicro SuperDoctor 5 is a program that functions in a command-line or web-based interface for Windows and Linux operating systems. The program monitors such system health information as CPU temperature, system voltages, system power consumption, fan speed, and provides alerts via email or Simple Network Management Protocol (SNMP).

SuperDoctor 5 comes in local and remote management versions and can be used with Nagios to maximize your system monitoring needs. With SuperDoctor 5 Management Server (SSM Server), you can remotely control power on/off and reset chassis intrusion for multiple systems with SuperDoctor 5 or IPMI. SuperDoctor 5 Management Server monitors HTTP, FTP, and SMTP services to optimize the efficiency of your operation.



**Note:** The default User Name and Password for SuperDoctor 5 is admin / admin.

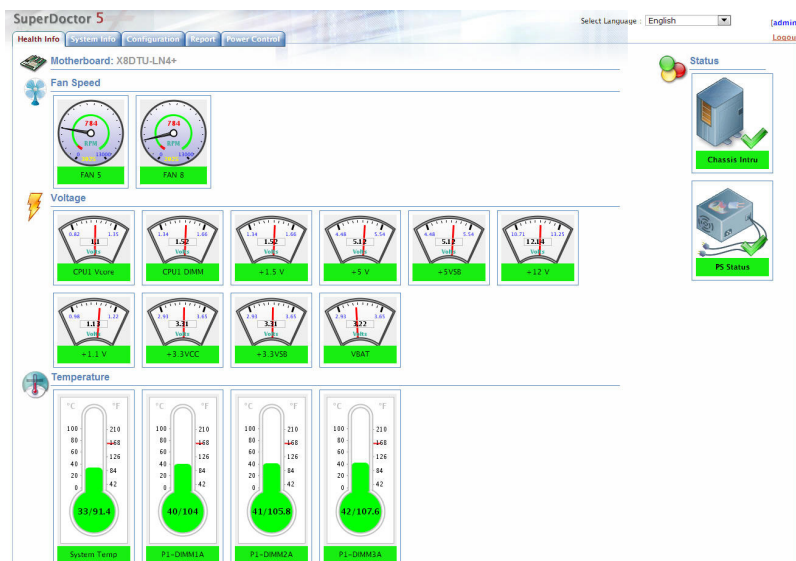


Figure B-2. SuperDoctor 5 Interface Display Screen (Health Information)



**Note:** The SuperDoctor 5 program and user's manual can be downloaded from the Supermicro website at [http://www.supermicro.com/products/nfo/sms\\_sd5.cfm](http://www.supermicro.com/products/nfo/sms_sd5.cfm).

## Appendix C

### Standardized Warning Statements

The following statements are industry standard warnings, provided to warn the user of situations which have the potential for bodily injury. Should you have questions or experience difficulty, contact Supermicro's Technical Support department for assistance. Only certified technicians should attempt to install or configure components.

Read this section in its entirety before installing or configuring components.

These warnings may also be found on our website at [http://www.supermicro.com/about/policies/safety\\_information.cfm](http://www.supermicro.com/about/policies/safety_information.cfm).

#### Battery Handling



**Warning!** There is the danger of explosion if the battery is replaced incorrectly. Replace the battery only with the same or equivalent type recommended by the manufacturer. Dispose of used batteries according to the manufacturer's instructions

#### 電池の取り扱い

電池交換が正しく行われなかった場合、破裂の危険性があります。交換する電池はメーカーが推奨する型、または同等のものを使用下さい。使用済電池は製造元の指示に従って処分して下さい。

#### 警告

電池更換不當會有爆炸危險。請只使用同類電池或制造商推薦的功能相當的電池更換原有電池。請按製造商的說明處理廢舊電池。

#### 警告

電池更換不當會有爆炸危險。請使用製造商建議之相同或功能相當的電池更換原有電池。請按照製造商的說明指示處理廢棄舊電池。

#### Warnung

Bei Einsetzen einer falschen Batterie besteht Explosionsgefahr. Ersetzen Sie die Batterie nur durch den gleichen oder vom Hersteller empfohlenen Batterietyp. Entsorgen Sie die benutzten Batterien nach den Anweisungen des Herstellers.

#### Attention

Danger d'explosion si la pile n'est pas remplacée correctement. Ne la remplacer que par une pile de type semblable ou équivalent, recommandée par le fabricant. Jeter les piles usagées conformément aux instructions du fabricant.

#### ¡Advertencia!

Existe peligro de explosión si la batería se reemplaza de manera incorrecta. Reemplazar la batería exclusivamente con el mismo tipo o el equivalente recomendado por el fabricante. Desechar las baterías gastadas según las instrucciones del fabricante.

#### אזהרה!

קיימת סכנת פיצוץ של הסוללה במידה והוחלפה בדרך לא תקינה. יש להחליף את הסוללה בסוג התואם מחברת יצרן מומלצת.

סילוק הסוללות המשומשות יש לבצע לפי הוראות היצרן.

هناك خطر من انفجار في حالة استبدال البطارية بطريقة غير صحيحة فعليك استبدال البطارية فقط بنفس النوع أو ما يعادلها كما أوصت به الشركة المصنعة تخلص من البطاريات المستعملة وفقا لتعليمات الشركة الصانعة

#### 경고!

배터리가 올바르게 교체되지 않으면 폭발의 위험이 있습니다. 기존 배터리와 동일하거나 제조사에서 권장하는 동등한 종류의 배터리로만 교체해야 합니다. 제조사의 안내에 따라 사용된 배터리를 처리하여 주십시오.

#### Waarschuwing

Er is ontploffingsgevaar indien de batterij verkeerd vervangen wordt. Vervang de batterij slechts met hetzelfde of een equivalent type die door de fabrikant aanbevolen wordt. Gebruikte batterijen dienen overeenkomstig fabrieksvoorschriften afgevoerd te worden.



## Product Disposal



**Warning!** Ultimate disposal of this product should be handled according to all national laws and regulations.

### 製品の廃棄

この製品を廃棄処分する場合、国の関係する全ての法律・条例に従い処理する必要があります。

### 警告

本产品的废弃处理应根据所有国家的法律和规章进行。

### 警告

本產品的廢棄處理應根據所有國家的法律和規章進行。

### Warnung

Die Entsorgung dieses Produkts sollte gemäß allen Bestimmungen und Gesetzen des Landes erfolgen.

### ¡Advertencia!

Al deshacerse por completo de este producto debe seguir todas las leyes y reglamentos nacionales.

### Attention

La mise au rebut ou le recyclage de ce produit sont généralement soumis à des lois et/ou directives de respect de l'environnement. Renseignez-vous auprès de l'organisme compétent.

### סילוק המוצר

אזהרה!

סילוק סופי של מוצר זה חייב להיות בהתאם להנחיות וחוקי המדינה.

عند التخلص النهائي من هذا المنتج ينبغي التعامل معه وفقا لجميع القوانين واللوائح الوطنية

### 경고!

이 제품은 해당 국가의 관련 법규 및 규정에 따라 폐기되어야 합니다.

### Waarschuwing

De uiteindelijke verwijdering van dit product dient te geschieden in overeenstemming met alle nationale wetten en reglementen.

## Appendix D

### UEFI BIOS Recovery

**Warning:** Do not upgrade the BIOS unless your system has a BIOS-related issue. Flashing the wrong BIOS can cause irreparable damage to the system. In no event shall Supermicro be liable for direct, indirect, special, incidental, or consequential damages arising from a BIOS update. If you need to update the BIOS, do not shut down or reset the system while the BIOS is updating to avoid possible boot failure.

#### D.1 Overview

The Unified Extensible Firmware Interface (UEFI) provides a software-based interface between the operating system and the platform firmware in the pre-boot environment. The UEFI specification supports an architecture-independent mechanism that will allow the UEFI OS loader stored in an add-on card to boot the system. The UEFI offers clean, hands-off management to a computer during system boot.

#### D.2 Recovering the UEFI BIOS Image

A UEFI BIOS flash chip consists of a recovery BIOS block and a main BIOS block (a main BIOS image). The recovery block contains critical BIOS codes, including memory detection and recovery codes for the user to flash a healthy BIOS image if the original main BIOS image is corrupted. When the system power is turned on, the recovery block codes execute first. Once this process is complete, the main BIOS code will continue with system initialization and the remaining POST (Power-On Self-Test) routines.



**Note 1:** Follow the BIOS recovery instructions below for BIOS recovery when the main BIOS block crashes.

**Note 2:** When the BIOS recovery block crashes, you will need to follow the procedures to make a Returned Merchandise Authorization (RMA) request. (For a RMA request, please see section 3.5 for more information). Also, you may use the Supermicro Update Manager (SUM) Out-of-Band (OOB) ([https://www.supermicro.com.tw/products/nfo/SMS\\_SUM.cfm](https://www.supermicro.com.tw/products/nfo/SMS_SUM.cfm)) to reflash the BIOS.


#### D.3 Recovering the Main BIOS Block with a USB Device

This feature allows the user to recover the main BIOS image using a USB-attached device without additional utilities used. A USB flash device such as a USB Flash Drive, or a USB CD/DVD ROM/RW device can be used for this purpose. However, a USB Hard Disk drive cannot be used for BIOS recovery at this time.

The file system supported by the recovery block is FAT (including FAT12, FAT16, and FAT32), which is installed on a bootable or non-bootable USB-attached device. However, the BIOS might need several minutes to locate the SUPER.ROM file if the media size becomes too large due to the huge volumes of folders and files stored in the device.

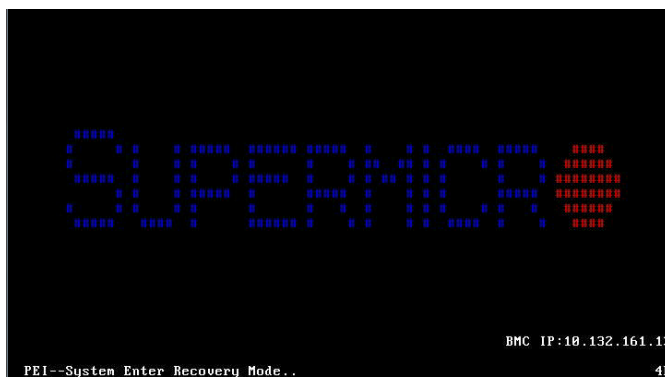
To perform UEFI BIOS recovery using a USB-attached device, follow the instructions below:


1. Using a different machine, copy the "Super.ROM" binary image file into the Root "\\" directory of a USB device or a writable CD/DVD.

 **Note 1:** If you cannot locate the "Super.ROM" file in your drive disk, visit our website at [www.supermicro.com](http://www.supermicro.com) to download the BIOS package. Extract the BIOS binary image into a USB flash device and rename it "Super.ROM" for BIOS recovery use.

**Note 2:** Before recovering the main BIOS image, confirm that the "Super.ROM" binary image file you download is the same version or a close version meant for your motherboard.

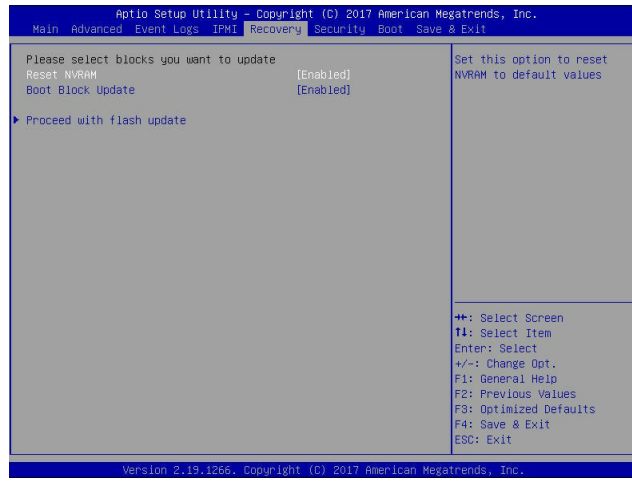
2. Insert the USB device that contains the new BIOS image ("Super.ROM") into your USB drive and reset the system until the following screen appears:




 **Note:** On the other hand, if the following screen displays, please load the "Super.ROM" file to the root folder and connect this folder to the system. (You can do so by inserting a USB device that contains the new "Super.ROM" image to your machine for BIOS recovery.)



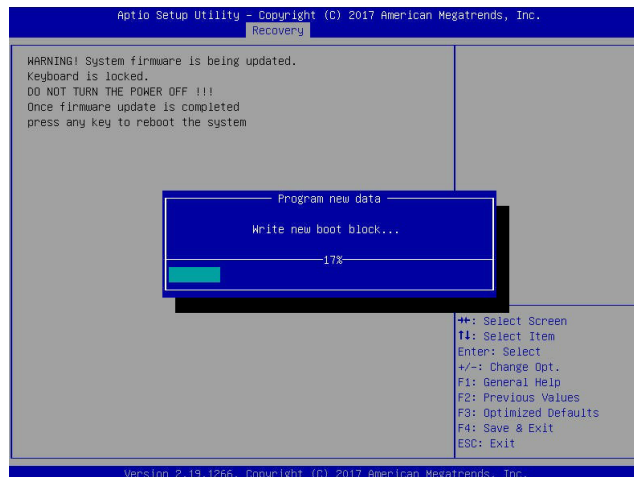
3. After locating the healthy BIOS binary image, the system will enter the BIOS Recovery menu as shown below:



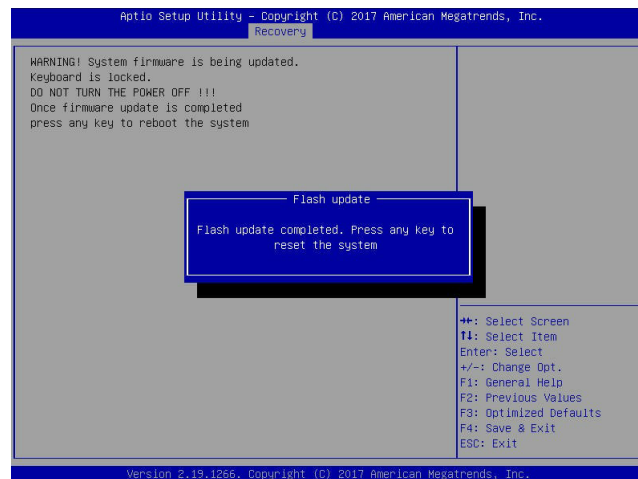
 **Note:** At this point, you may decide if you want to start the BIOS recovery. If you decide to proceed with BIOS recovery, follow the procedures below.

4. When the screen as shown above displays, use the arrow keys to select the item "Proceed with flash update" and press the <Enter> key. You will see the BIOS recovery progress as shown in the screen below:

 **Note:** Do not interrupt the BIOS flashing process until it has completed.



5. After the BIOS recovery process is complete, press any key to reboot the system.



6. Using a different system, extract the BIOS package into a bootable USB flash drive.
7. When a DOS prompt appears, enter FLASH.BAT BIOSname.### at the prompt.



**Note:** Do not interrupt this process until the BIOS flashing is complete.

8. After seeing the message indicating the BIOS update has completed, unplug the AC power cable from the power supply, clear CMOS, then plug the AC power cable in the power supply again to power on the system.
9. Press <Del> continuously to enter the BIOS Setup utility.
10. Press <F3> to load the default settings.
11. After loading the default settings, press <F4> to save the settings and exit the BIOS Setup utility.