

Owner's Manual

Combination Laptop Security Lock – 6 ft. Cable

Model: SEC6C

PROTECT YOUR INVESTMENT!

Register your product for quicker service
and ultimate peace of mind.

You could also win an ISOBARGULTRA
surge protector—a \$100 value!

www.tripplite.com/warranty

Setting the Combination

The factory preset combination is 0-0-0-0.

- 1 Press and hold button **A**. Set your 4-digit combination and release the button.
- 2 Slide button **B** to the right.
Your combination is now set.

**IMPORTANT: Memorize your combination
or write it down for future reference:**



No master combination or key is
available from the manufacturer,
should the user combination be
forgotten or lost.

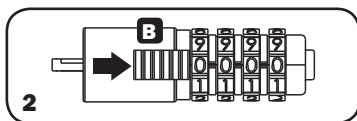
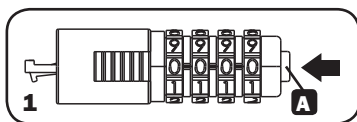

Locking Equipment

- 1 Find an object (e.g. table) to secure
the lock and run the lock through
the cable loop.
- 2 Slide button **A** to the right and
insert the lock into the computer
slot. Release button **B** and mix
the number combination. Your
equipment is now locked.

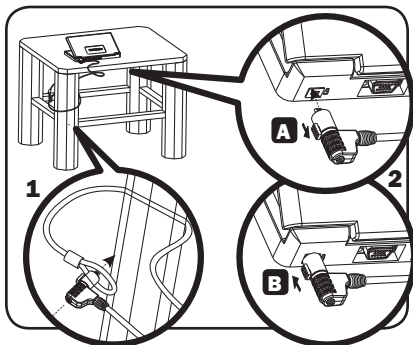

TRIPP-LITE

90
OVER
YEARS
Manufacturing
Excellence.

1111 W. 35th Street, Chicago, IL 60609 USA • www.tripplite.com/support

Copyright © 2016 Tripp Lite. All rights reserved.

Unlocking Equipment

- 1 Set the lock's dials to your 4-digit combination. Then slide button **B** to the right to disengage the lock.

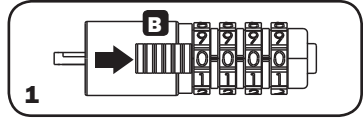

Resetting the Combination

- 1 Set the lock's dials to your current 4-digit combination. Press and hold button **A** and **do not release**. Set your 4-digit combination and release the button.
- 2 Immediately slide button **B** to the right. Your combination is now reset.

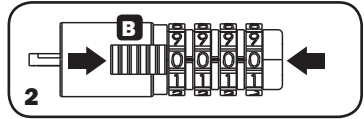
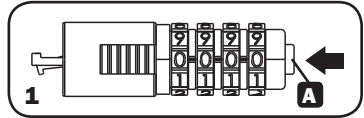

Warranty and Product Registration

1-Year Limited Warranty

TRIPP LITE warrants its products to be free from defects in materials and workmanship for a period of one (1) year from the date of initial purchase. TRIPP LITE's obligation under this warranty is limited to repairing or replacing (at its sole option) any such defective products. To obtain service under this warranty, you must obtain a Returned Material Authorization (RMA) number from TRIPP LITE or an authorized TRIPP LITE service center. Products must be returned to TRIPP LITE or an authorized TRIPP LITE service center with transportation charges prepaid and must be accompanied by a brief description of the problem encountered and proof of date and place of purchase. This warranty does not apply to equipment, which has been damaged by accident, negligence or misapplication or has been altered or modified in any way.

EXCEPT AS PROVIDED HEREIN, TRIPP LITE MAKES NO WARRANTIES, EXPRESS OR IMPLIED, INCLUDING WARRANTIES OF MERCHANTABILITY AND FITNESS FOR A PARTICULAR PURPOSE.

Some states do not permit limitation or exclusion of implied warranties; therefore, the aforesaid limitation(s) or exclusion(s) may not apply to the purchaser.

EXCEPT AS PROVIDED ABOVE, IN NO EVENT WILL TRIPP LITE BE LIABLE FOR DIRECT, INDIRECT, SPECIAL, INCIDENTAL OR CONSEQUENTIAL DAMAGES ARISING OUT OF THE USE OF THIS

PRODUCT, EVEN IF ADVISED OF THE POSSIBILITY OF SUCH DAMAGE. Specifically, TRIPP LITE is not liable for any costs, such as lost profits or revenue, loss of equipment, loss of use of equipment, loss of software, loss of data, costs of substitutes, claims by third parties, or otherwise.

PRODUCT REGISTRATION

Visit www.triplite.com/warranty today to register your new Tripp Lite product. You'll be automatically entered into a drawing for a chance to win a FREE Tripp Lite product!*

* No purchase necessary. Void where prohibited. Some restrictions apply. See website for details.

Tripp Lite has a policy of continuous improvement. Specifications are subject to change without notice.



1111 W. 35th Street, Chicago, IL 60609 USA • www.triplite.com/support

16-08-522 93-363F_RevA