

Scale Computing Cluster Installation Guide

HyperCore

This document supports the version of product listed and all subsequent versions until the document is replaced by a new edition. Check for new editions of this document at <http://www.scalecomputing.com/support/login/>.



Scale Computing HyperCore Cluster Installation Guide

You can find the most up-to-date technical documentation on the Scale Computing Portal at:

<http://www.scalecomputing.com/support/login/>

The Scale Computing site also provides the latest product updates and information:

<http://www.scalecomputing.com/>

Provide feedback on this document at:

documentation@scalecomputing.com

Contact support at:

support@scalecomputing.com

<http://www.scalecomputing.com/support/login/>

US: +1-877-SCALE-59 (877-722-5359)

Europe: 0808 234 0699

Document Version 1.3

Corporate Headquarters
5225 Exploration Drive
Indianapolis, IN 46241
P. +1 877-722-5359

West Coast Office
360 Ritch Street
Suite 300
San Francisco, CA 94107

EMEA Office
Saunders House
52-53 The Mall
London
W5 3TA
United Kingdom

www.scalecomputing.com

1-877-SCALE-59 (877-722-5359)

Contents

	About	4
1	Port and Switch Requirements	5
	Port Requirements	5
	Switch Requirements	5
	Tips for Working with Switches	5
2	Power Requirements	7
	HCI1000 Series Nodes	7
	HCI1100 Series Nodes	7
	HCI1150 Series Nodes	8
	HC2000 / HC2100 Series Nodes	8
	HC4000 Series Nodes	8
	HC4100 Series Nodes	9
3	Pre-Installation Checklist	10
	Equipment and Information	10
	Scheduling	10
4	Provisioning IP Addresses	11
	Backplane IP Addresses	11
	LAN IP Addresses	11
	Tips and Examples for IP Addressing	12
5	Schedule Your Installation	13
	Customer Portal Access	13
	Partner and Distributor Portal Access	13
	Login or Register for a Portal Account	14
	Complete the Installation Environment Form and Schedule	15
6	Choosing a Cluster Configuration	18
	Switch and Node Redundancy	18
	Configuration with Mixed Nodes	18
7	Rack and Cable the Nodes	20
	Rail Kit Contents for HCI1000 Series Nodes	20
	Install Slides and Rails for HCI1000 Series Nodes	21
	Install the HCI1000 Series Node into the Rack	23
	Install the HC2000 and HC4000 Series Nodes into the Rack	23
	Cable the Nodes	25
8	Node and Cluster Configuration	26
	Configuration Checklist	26
	Configure and Initialize the Nodes	26

Document Feedback

Scale Computing welcomes your suggestions for improving our documentation. If you have any comments or suggestions please send your feedback to documentation@scalecomputing.com.

Technical Support and Resources

There are many technical support resources available for use. Access this document, and many others, at <http://www.scalecomputing.com/support/login/>.

Online Support You can submit support cases and view account information online through the Portal at <http://www.scalecomputing.com/support/login/>. You can also Live Chat with support through www.scalecomputing.com during standard hours Monday-Friday 8-8 EDST.

Telephone Support Support is available for critical issues 24/7 by phone at 1-877-SCALE-59 (877-722-5359) in the US and at 0808 234 0699 in Europe. Telephone support is recommended for the fastest response on priority issues, and the only response after standard Support hours.

Professional Resources Scale Computing offers many professional service options for both remote and on-site assistance in getting your new cluster off the ground quickly and knowledgeably. Contact your Scale Computing sales representative today to discuss our offerings that include options like the HC3 ScaleCare Network Configuration, the HC3 ScaleCare Migration, or even the HC3 ScaleCare Full Implementation. Find additional information at <http://www.scalecomputing.com/products/hc3-scale-care-services>.

Port and Switch Requirements

Firewalls and switches

The cluster environment and selected switches must meet specific requirements to ensure proper operation during and after the installation.

The following topics are included in this chapter:

- **Port Requirements**
- **Switch Requirements**
- **Tips for Working with Switches**

Port Requirements

This section details what ports to leave open in your network firewall for your cluster to operate correctly.

- **Network Time Protocol (NTP)** - User Datagram Protocol (UDP), Port 123
- **Outgoing Simple Mail Transfer Protocol (SMTP) Server** - Transmission Control Protocol (TCP), Port 25
- **Scale Cluster Replication** - TCP, Port 5161, 5162, 5163
- **Outbound Secure Shell (SSH)** - TCP, Port 22, for use with `remote-support.scalecomputing.com`
- **Firmware Updates** - TCP, Port 80, 443, for use with `updates.scalecomputing.com`

Switch Requirements

Please reference the [Networking Guidelines and Recommendations](#) guide available on the Scale Computing Website for the most up-to-date information.

Tips for Working with Switches

Provided here are tips on working with the recommended switches for the best cluster performance.

- The backplane IP address assigned to the nodes will always default to a Class C (255.255.255.0) subnet.
- When setting up the switch for your backplane VLAN and choosing your backplane IPs, make sure the VLAN is not routable anywhere else on the network and the subnet is unique on the network.
- If you are using one switch for both the backplane network and LAN network, always use the LAN subnet to manage the switch.
- Turn off STP on the ports that the Scale cluster connects to whenever possible. If your switch is not able to adjust STP settings on a per-port basis, the entire switch must be removed from the STP domain.
- In general, do not tag the backplane VLAN ports unless specifically instructed by your applicable switch configuration guide or if required for your specific network. The LAN side may be tagged for some networks. Tagging ports is an advanced configuration not covered in this guide.

- Minimize the time spent moving the switch around or unplugging nodes from the switch once it is in place with the initialized cluster. Once initialized, backplane disruption will cause significant issues to data availability and cluster stability.

2

Power Requirements

Power and heat details

It is important to ensure each node in the cluster will have the proper power and cooling available.

The following topics are included in this chapter:

- **HCI 1000 Series Nodes**
- **HCI 1100 Series Nodes**
- **HCI 1150 Series Nodes**
- **HC2000 / HC2100 Series Nodes**
- **HC4000 Series Nodes**
- **HC4100 Series Nodes**

HCI 1000 Series Nodes

Power and heat information for HCI 1000 series nodes.

Operating Power	158.4 watts
Operating Heat	542.5 btu/h
Maximum Potential Power	390.2 watts
Maximum Potential Heat	1331.5 btu/h
Power Supply Capacity	650 watts
Power Supply Heat	2217.8 btu/h
Input Current	2.5 amps
Sound Power Level	6.9 bels
Weight	36 lbs

HCI 1100 Series Nodes*

Power and heat information for HCI 1100 series nodes.

	Idle	Load	Startup	Staging
Watts	92.6	161.4	116	14.1
Amps	0.746	1.336	0.6	0.095
kVA	0.0926	0.1614	0.116	0.0141
BTU/hr	315.95	550.70	395.79	48.11
Test Voltage	120.7	120.2	120.3	120.6

*Various upgrades such as CPU and 10 GbE NICs will add 5 to 12 Watts to the node. This should be taken into consideration.

HC1150 Series Nodes*

Power and heat information for HC1150 series nodes.

	Idle	Load	Startup	Staging
Watts	99.3	116.83	136.1	13.95
Amps	0.84	0.954	1.106	0.89
kVA	0.0993	0.11683	0.1361	0.01395
BTU/hr	358.81	398.62	464.37	47.60
Test Voltage	120.2	120.4	119.95	120.93

HC2000 / HC2100 Series Nodes

Power and heat information for HC2000 / HC2100 series nodes.

Operating Power	270 watts
Operating Heat	921.3 btu/h
Maximum Potential Power	390.2 watts
Maximum Potential Heat	1331.5 btu/h
Power Supply Capacity	350 watts
Power Supply Heat	1194.2 btu/h
Input Current	2.5 amps
Sound Power Level	6.9 bels
Weight	42.5 lbs

HC4000 Series Nodes

Power and heat information for HC4000 series nodes.

Operating Power	389 watts
Operating Heat	1327.3 btu/h
Maximum Potential Power	601.5 watts
Maximum Potential Heat	2052.5 btu/h
Power Supply Capacity	750 watts
Power Supply Heat	2559.1 btu/h
Input Current	3.5 amps
Sound Power Level	6.8 bels
Weight	43.6 lbs

*Various upgrades such as CPU and 10 GbE NICs will add 5 to 12 Watts to the node. This should be taken into consideration.

HC4100 Series Nodes

Power and heat information for HC4100 series nodes.

Operating Power	428 watts
Operating Heat	1460.4 btu/h
Maximum Potential Power	639 watts
Maximum Potential Heat	2180.3 btu/h
Power Supply Capacity	750 watts
Power Supply Heat	2559.1 btu/h
Input Current	3.9 amps
Sound Power Level	7.1 bels
Weight	40.6 lbs

3

Pre-Installation Checklist

Installation necessities

These are brief checklists of the items and information you will need for a smooth installation of your new Scale Computing cluster.

The following topics are included in this chapter:

- **Equipment and Information**
- **Scheduling**

Equipment and Information

You will need the following equipment and information available prior to the installation:

- Supported switch(es) for the LAN and backplane connections, configured per Scale's best practices
- CAT5e, CAT6, or SFP+ cable, depending on your node series and performance needs
- A Phillips-head screwdriver for installing the rail kit
- At least one un-interruptible power supply (UPS) is recommended for power redundancy
- A list of the IPs you have assigned for the node LAN and backplane connections, your cluster network subnet mask, and your cluster network gateway
- A standard VGA monitor and USB keyboard to hook to the nodes for configuration
- A copy of the current Scale Computing User Guide
- Any other applicable cables, tools, or network information required for your environment

Scheduling

You will need to complete the following steps to prepare for and schedule your installation with Scale Computing support. Further information on these steps can be found in **Chapter 5, Schedule Your Installation**.

- Obtain access to the online Portal if you do not already have an account
- Complete the online Environment form for your installation case
- Schedule a pre-installation call to speak to an installation specialist about the installation process, plans, requirements, and best practices for the installation and cluster
- Schedule an installation date with an installation specialist (the pre-installation call MUST

4

Provisioning IP Addresses

Selecting IPs

Always consider the information on backplane and LAN IPs when selecting IPs for your new nodes. There are tips and examples for an IP address scheme for a Scale cluster as well.

The following topics are included in this chapter:

- **Backplane IP Addresses**
- **LAN IP Addresses**
- **Tips and Examples for IP Addressing**

Backplane IP Addresses

The backplane ports on any Scale node are in an active / passive bond used for failover. This means that only one backplane port is ever active at a time. There is a default primary and secondary port; which physical port that is can differ between node series. For redundancy, both backplane ports on a node should always be cabled in to your switch(es).

Backplane IP addresses should be assigned from a private subnetwork used solely by your cluster's nodes to communicate with other nodes of the same cluster and non-routable from any other part of the network. These addresses are used **only** for intra-cluster communication between nodes, cluster data striping, and cluster data mirroring. The cluster backplane is critical to cluster operation as the backbone of the system, and it is what makes the separate nodes a single cluster once they are initialized.

Due to their importance, backplane IP addresses are **permanent**. Once set, they cannot be changed without an entire cluster reset, which would wipe all data and configurations on the cluster.

LAN IP Addresses

The LAN ports on any Scale node are in an active / passive bond used for failover. This means that only one LAN port is ever active at a time. There is a default primary and secondary port; which physical port that is can differ between node series. For redundancy, both LAN ports on a node should always be cabled in to your switch(es).

LAN IP addresses should be assigned from your primary data network and are used by your cluster's nodes to communicate data between the cluster and network. These addresses are used **only** for data communication and HC3 web interface access. Due to their nature, LAN IP addresses can be changed. It is currently a manual process that must be done from the node command line (cli) and does require a maintenance window. You can adjust the LAN IP, subnet mask, and network gateway as necessary.

Tips and Examples for IP Addressing

Below are some tips to keep in mind, if possible, when you are assigning LAN and backplane IP addresses:

- Backplane IP addresses should match the last octet of LAN IP addresses when possible; for example, LAN IP 192.168.100.10 would have a matching backplane IP of 1.1.1.10.
- LAN IP addresses should be provisioned in the same block, with room for node additions later; for example, a four node cluster would have a LAN IP scheme of 10.100.1.11, 10.100.1.12, 10.100.1.13, and 10.100.1.14 and then 10.100.1.15-18 would be blocked out for subsequent nodes down the road as necessary.
- Always keep your network environment in mind when assigning IPs; not every recommendation is going to be applicable or possible for every network environment.

WARNING

It is against Scale Computing best practices to use a publicly routable IP address scheme for the LAN IP addresses on your nodes. Choose a non-publicly routable IP addressing scheme for the LAN ports. If it is necessary to have public access to VMs on the cluster, utilize individual VM VLAN capabilities to control access to the VMs only, not to the cluster nodes.

Below is an example IP scheme for a four node cluster. This is **not** the required IP scheme, but an example of proper assignment using best practices. You should use an IP scheme that is compatible with your network environment.

- LAN IP - 192.168.155.20
- LAN IP - 192.168.155.21
- LAN IP - 192.168.155.22
- LAN IP - 192.168.155.23
- LAN Subnet Mask - 255.255.255.0
- LAN Gateway 192.168.155.1
- Backplane IP - 10.10.10.20
- Backplane IP - 10.10.10.21
- Backplane IP - 10.10.10.22
- Backplane IP - 10.10.10.23
- Backplane Subnet Mask (Permanent) - 255.255.255.0

5

Schedule Your Installation

Portal and scheduling

Steps for obtaining Portal access in order to monitor, manage, and schedule your Scale cluster installation. The Portal also provides case management, asset management, Knowledge documentation, forums, and question boards.

The following topics are included in this chapter:

- **Customer Portal Access**
- **Partner and Distributor Portal Access**
- **Login or Register for a Portal Account**
- **Complete the Installation Environment Form and Schedule**

Customer Portal Access

The customer Portal is for customer use only. Customers can use the Portal to:

- Manage account information
- Access assets
- Access shipments
- Access entitlements for support
- Create and manage support cases
- Access the Knowledge base for documentation, guides, application notes, frequently asked questions (FAQs), and best practices
- Access forums and question boards
- Contact representatives directly

Customers automatically receive access to the customer Portal when they buy Scale nodes for the first time. Once the nodes have been shipped, customers will receive an email from myscale@scalecomputing.com containing login information. Additional contacts from the company who are associated with the account can register for a new login from the proper Portal page linked at <http://www.scalecomputing.com/support/login/> after the initial purchase.

For more information about how to register for a new login at the Portal page, refer to [Login or Register for a Portal Account](#).

Partner and Distributor Portal Access

The partner Portal is for partners and distributors only. Partners can use the Portal to:

- Manage account information and view contacts
- Register deals, update existing registrations, and work assigned leads
- Access training materials, forums, and question boards
- Access the Knowledge database for documentation, guides, application notes, frequently asked questions (FAQs), and best practices
- Contact representatives directly
- Manage customer accounts

Distributors can use the Portal to:

- Manage account information and view contacts
- Register deals, update existing registrations, and work assigned leads
- View all deal registrations by their value added resellers (VARs)
- Access training materials, forums, and question boards
- Access the Knowledge database for documentation, guides, application notes, frequently asked questions (FAQs), and best practices
- Contact representatives directly

Partners and distributors automatically receive access to the partner Portal when they sign Scale's partner agreement. After the agreement is signed, the partner account is activated and the partner receives an email from myscale@scalecomputing.com containing login information. After that time, additional partner contacts associated with the partner that signed the agreement can register for a new login from the proper Portal page linked at <http://www.scalecomputing.com/support/login/>. For more information about how to register for a new login at the Portal page, refer to [Login or Register for a Portal Account](#).

Login or Register for a Portal Account

Register for a Portal account using the following steps:

1. Open a web browser and navigate to www.scalecomputing.com.
2. Click **Login** in the upper right hand corner.
3. If you are a customer, click the **Customer Portal** link. If you are a partner or distributor, click the **Partner Portal** link.
4. The **Login** screen shown in **Figure 5-1** appears. The login screen is the same for both the customer Portal and partner Portal, so please be sure you are at the proper landing.

Figure 5-1

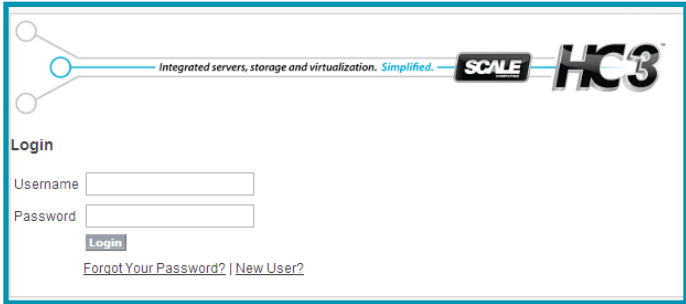

Integrated servers, storage and virtualization. Simplified. **SCALE HC3**

Login

Username

Password

[Forgot Your Password?](#) | [New User?](#)

5. If you have login credentials, type your username and password in the appropriate fields to access the Portal.
6. If you are an additional partner, distributor, or customer, registering after initial access was granted, click **New User?** underneath the **Username** and **Password** fields. The **New User Registration** screen will appear as shown in **Figure 5-2**.

The screenshot shows the 'New User Registration' page for Scale HC3. At the top, there is a logo for Scale HC3 with the tagline 'Integrated servers, storage and virtualization. Simplified.' Below the logo, the page title is 'New User Registration'. The form is organized into three main sections: 'Account Information', 'Contact Information', and 'Address Information'. Each section contains several input fields. In the 'Account Information' section, the 'Email (Username)' field has a red vertical bar on its left side, indicating it is required. Similarly, the 'Community Nickname' field also has a red bar. The 'Password' and 'Confirm Password' fields are present but do not have red bars. The 'Contact Information' section includes fields for 'Company Name', 'First Name', 'Last Name', 'Phone', and 'Role', all of which have red bars. The 'Address Information' section includes fields for 'Country', 'Street', 'City', 'State', and 'Postal Code', all with red bars. At the bottom right of the form, there is a blue 'Register' button.

Figure 5-2

7. The registration screen is the same for partners, distributors, and customers; only the pathway differs. Ensure you are at the correct landing.
8. Provide the appropriate information for the three categories: **Account Information**, **Contact Information**, and **Address Information**. The **Email (Username)** field will default to your Portal username for future access. The **Community Nickname** field will be your general-use name in the forums and chat boards. All fields marked in red are required.
9. Disregard the **Password** and **Confirm Password** fields. Your password is generated for you after registration and sent to you by email. If you do fill out a password here it is ignored by the system.
10. Click **Register** once the form is complete. If you registered for the customer Portal and Scale finds an exact match for the account name you provided you will immediately receive your new password via email. If you registered for the customer Portal and no match is found, your request is logged and reviewed for approval. If you are a partner or distributor, your request is always logged and reviewed for approval prior to receiving your password.

You are now registered for a Portal account. After access is granted, the account entitles you to the same offerings as the initial partner or customer account that was registered for your group or company.

Complete the Installation Environment Form and Schedule

Before you can schedule your installation for your cluster you must complete the online Environment form in the Portal. This form is a way for Scale's installation specialists to better understand your environment, the cluster needs, and the expectations for the cluster.

1. Open a web browser and navigate to www.scalecomputing.com.
2. Log in to the customer or partner Portal as appropriate.
3. Select **My Profile** and ensure your timezone is set properly. All scheduling is based on this timezone setting.
4. Point to **Support** and a drop down menu will appear. Select **Installations** from the

drop down choices.

5. Click **Update Environment** on the far left of the appropriate installation case.
6. The **Environment** form will appear as shown in **Figure 5-3**. Select **Edit** to complete the form. Find quick tips and hints for the form and your installation using the **Quick Start Guide** link. You can select **Schedule** from the form or the main Installations page once the Environment form has been completed to schedule your pre-installation call and installation.

Figure 5-3

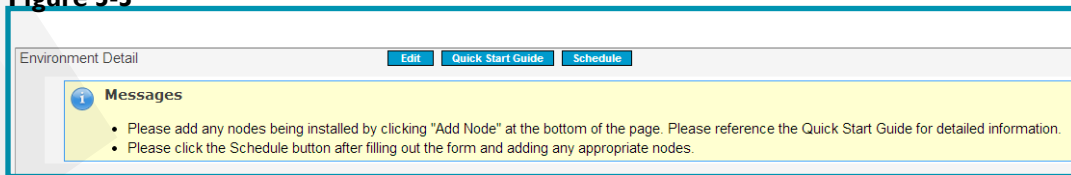

7. You will not be able to schedule anything until the Environment form has been completed and saved. You will see the error in **Figure 5-4** if you try to schedule before the Environment form is completed.

Figure 5-4

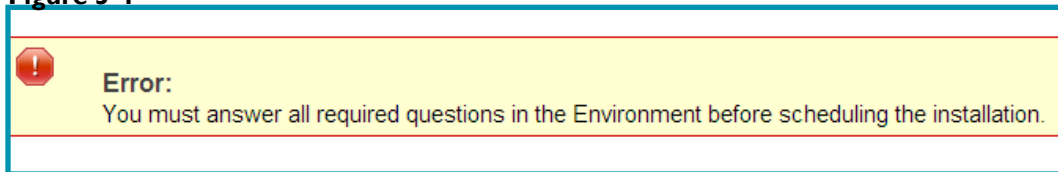

8. Add nodes to the Environment form using the **New Node** link at the bottom of the form shown in **Figure 5-5**. This records the expected IP scheme for your installation specialist to have on hand during the scheduled installation call.

Figure 5-5

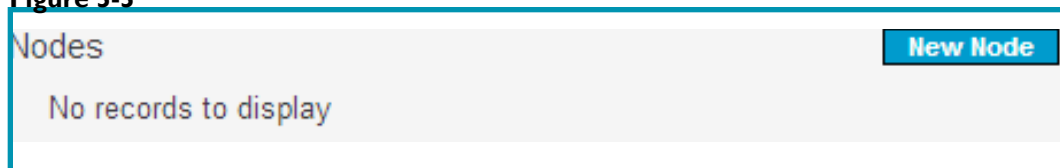

9. Schedule the **Pre-Installation Call** and **Installation** using either of the two options mentioned in **Step 6** above. You will be prompted for the Pre-Installation Call first. By default **No** is selected as shown in **Figure 5-6**. Select **Yes**. The screen in **Figure 5-7** will be shown.

Figure 5-6

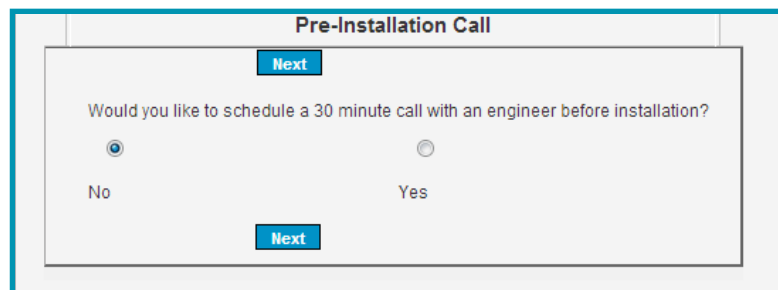

Onboarding Process

Pre-Installation Call

Would you like to schedule a 30 minute call with an engineer before installation?

No Yes

Please select a date/time for your planning call. Your call will take 30 minutes

Phone number for call

Contact name for call

Please choose from the available list of dates:

February 2013

Sun	Mon	Tue	Wed	Thu	Fri	Sat
27	28	29	30	31	01	02
03	04	05	06	07	08	09
10	11	12	13	14	15	16
17	18	19	20	21	22	23
24	25	26	27	28	01	02

Next

Figure 5-7

10. Complete the **Phone number for call** and **Contact name for call** fields. Select an available date from the calendar. A list of times will appear to the right of the calendar as shown in **Figure 5-8**.

Onboarding Process

Pre-Installation Call

Would you like to schedule a 30 minute call with an engineer before installation?

No Yes

Please select a date/time for your planning call. Your call will take 30 minutes

Phone number for call

Contact name for call

Please choose from the available list of dates:

March 2013

Sun	Mon	Tue	Wed	Thu	Fri	Sat
23	24	25	26	27	28	29
30	01	02	03	04	05	06
07	08	09	10	11	12	13
14	15	16	17	18	19	20
21	22	23	24	25	26	27
28	29	30	31			

Available Time Slots on 3/5/2013
*All times are listed in your current time zone.

Select	Time Slot
Select	8:00 AM - 8:30 AM
Select	8:15 AM - 8:45 AM
Select	8:30 AM - 9:00 AM
Select	8:45 AM - 9:15 AM
Select	9:00 AM - 9:30 AM
Select	9:15 AM - 9:45 AM
Select	9:30 AM - 10:00 AM
Select	9:45 AM - 10:15 AM
Select	10:00 AM - 10:30 AM
Select	10:15 AM - 10:45 AM
Select	10:30 AM - 11:00 AM
Select	10:45 AM - 11:15 AM
Select	11:00 AM - 11:30 AM
Select	11:15 AM - 11:45 AM
Select	11:30 AM - 12:00 PM
Select	11:45 AM - 12:15 PM

Figure 5-8

11. Select a time and click **Next**.
12. You may now schedule the **Installation**. The Installation should be scheduled at minimum 24 hours after the requested Pre-Installation Call. Follow the same process as **Step 9 to Step 12** above to schedule the Installation.
13. Read the **Terms & Conditions**. If you agree, select the **I Agree** option and click **Submit**.
14. A confirmation will be shown for your scheduled appointments. You will also receive an email confirmation for each event scheduled. Be sure to verify the listed dates and times in the email and Portal confirmations.
15. Any appointments that need to be rescheduled less than 24 hours in advance will have to be done manually by calling 1-877-SCALE-59. Availability may be limited.

6 Choosing a Cluster Configuration

Redundancy, failover, and performance

Information on choosing a cluster network and node configuration that is right for your environment.

The following topics are included in this chapter:

- **Switch and Node Redundancy**
- **Configuration with Mixed Nodes**

Switch and Node Redundancy*

Scale Computing nodes are designed for network and data redundancy. This section offers tips and best practices for fully utilizing these features.

- Use two switches for each cluster and balance one LAN and one backplane connection on each switch, separated by VLANs with interconnects between the switches; this configuration ensures not only port failover on the nodes, but also port failover on the switches and full switch redundancy if a switch were to fail.
- Use two different UPS for each of the cluster nodes' power supplies and switches, and even different power circuits; this configuration ensures the best possible node and switch power redundancy.
- Always use all four network ports on the nodes, both LAN and both backplane.
- Always use both power supplies on the nodes.
- Nodes should not be geographically dispersed amongst different physical locations; when you set up nodes for your cluster, select one physical location for each cluster.

Configuration with Mixed Nodes

Scale Computing nodes are designed to mix and match in almost all situations for the ideal solution of storage and compute power. In this section you will find some general best practices and considerations for mixing different series of nodes in a single cluster.

- Always match drive sizes in a cluster; if you require more capacity than the current node series can provide, you will need to have at least two nodes of the same drive capacity for proper data redundancy and capacity management.
- Keep your virtual machine (VM) memory (RAM) needs in mind when mixing nodes; ensure you always have enough free RAM available for any single node of VMs to failover to other nodes, particularly large-RAM VMs.
- Different node series offer different drive speeds with SAS and SATA offerings; be aware when mixing SAS and SATA drives that you will always be limited by the slowest drives in daily operations and this can impact performance on the cluster when reading and writing data.
- Adding SAS drives to a SATA cluster will not increase overall cluster performance due to the bottleneck caused by the slower SATA drives as mentioned above.
- Consider drive data mirroring and drive sizes when combining four-drive and eight-drive nodes. Scale offers 1 GB and 10 GB network connections depending on the node series;

* Some of the High Availability features and best practices will not be available / applicable with the Single Node Appliance Configuration.

it is important to remember that a cluster running this combination is always going to be bottlenecked by the 1 GB connections, and the different nodes will require different cable and switch hardware.

- When using the Single Node Appliance Configuration please keep in mind that there is no VM failover available. This means that any maintenance or HyperCore firmware updates will require downtime.

7

Rack and Cable the Nodes

Setting things up

Installing the nodes into the rack and cabling the power and networking for the installation.

The following topics are included in this chapter:

- **Rail Kit Contents for HCI1000 Series Nodes**
- **Install Slides and Rails for HCI1000 Series Nodes**
- **Install the HCI1000 Series Nodes into the Rack**
- **Install the HC2000 and HC4000 Series Nodes into the Rack**
- **Cable the Nodes**

Rail Kit Contents for HCI1000 Series Nodes

A rail kit accompanies each node in your cluster and includes:

- **Three pairs of short brackets** as shown in **Figure 7-1**. Two pairs are threadless and one pair is threaded. It is very likely you will only need one pair. Choose threaded or threadless based on what is most appropriate for your rack.

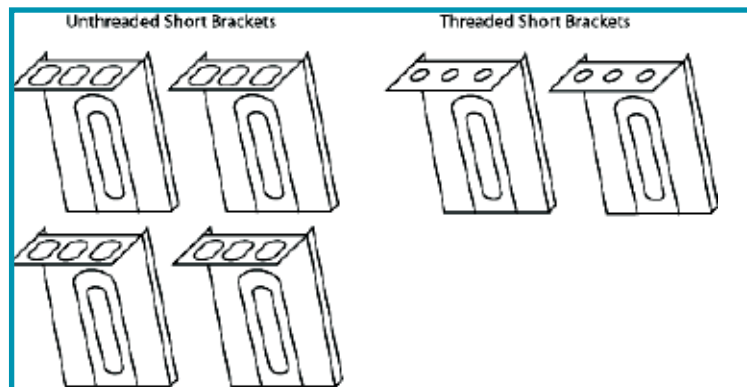

Figure 7-1

- **One pair of front chassis slides** as shown in **Figure 7-2**. These will arrive already assembled on your chassis.



Figure 7-2

- **One pair of back chassis slides** as shown in **Figure 7-3**. These are mounted on the back of the chassis.

Figure 7-3



- **One pair of back rack rails** as shown in **Figure 7-4**. These will be installed on the back of the rack.

Figure 7-4

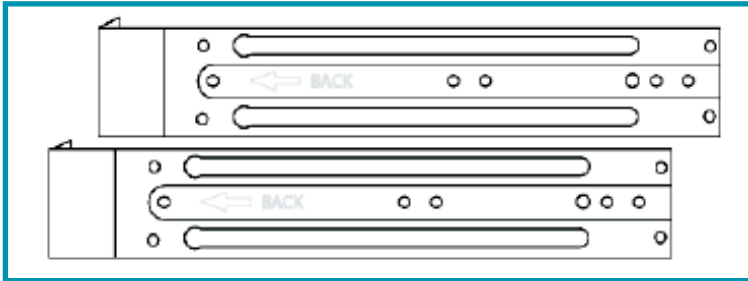

- **One pair of long brackets** as shown in **Figure 7-5**. These are mounted on the rack.

Figure 7-5

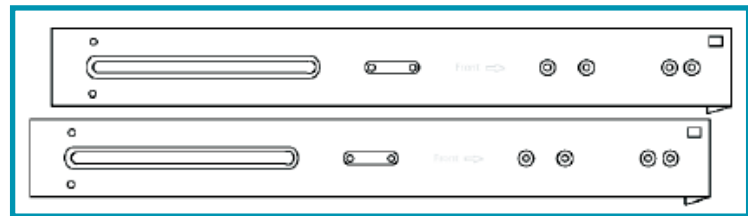

- **Eight panhead screws** as shown in **Figure 7-6**, **eight small flathead screws**, and **eight large flathead screws** as shown in **Figure 7-7**. **Eight washers**, not shown.

Figure 7-6

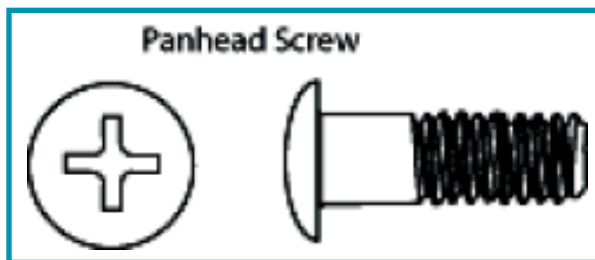
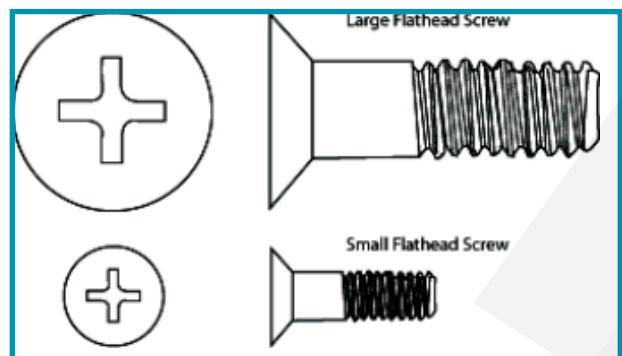

Figure 7-7



Install Slides and Rails for HCI1000 Series Nodes

In order to slide your node in and out of the rack, add slides to the sides and back of the node chassis, then configure the slide assembly for the rack. This process will need to be done for each node.

The front chassis slides are already installed on the nodes. The back rack rails and the long bracket combine to create an outer slide assembly that matches the length of your rack. The pieces you need for each node's assembly are:

- A node
- Front chassis slides (2)
- Back chassis slides (2)
- Panhead screws (8)
- Back rack rails (2)
- Long brackets (2)
- Short brackets (2)
- Phillips-head screwdriver
- Measuring tape (optional)

Installing slides on the node chassis follow the same steps for each node:

1. Orient the slide so the black plastic catch on each faces towards the front of the node. The front slide will have the D-shaped finger hold, the back slide will not. See **Figure 7-8**.

Figure 7-8

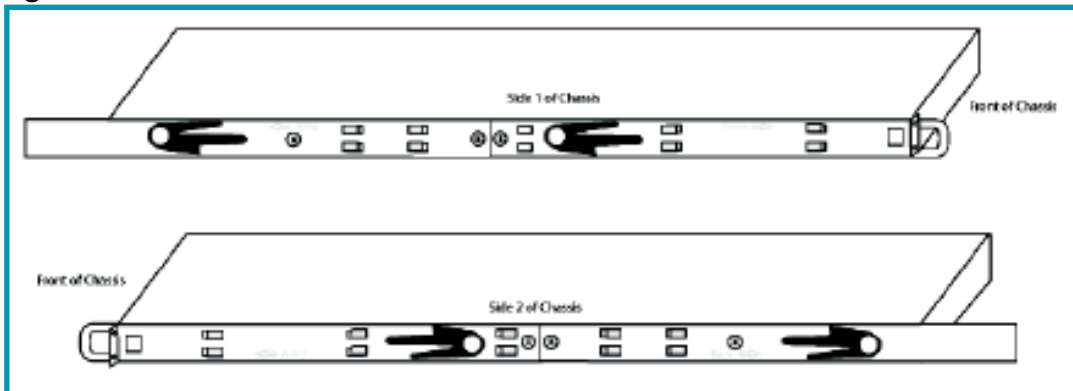

2. Line up the 4 rectangular holes on the slide with the hooks on the side of the chassis and slide it in place. Ensure that the black plastic catch faces out from the chassis so you can see it.
3. Use the panhead screws to secure each slide in place in the pre-drilled holes.

Configuring the back rack rail and rack bracket follow these steps for each node:

1. Slide the long bracket into the back rack rail as shown in **Figure 7-9**. Ensure the long bracket is oriented so the word **Front** and the arrow are facing the front.

Figure 7-9

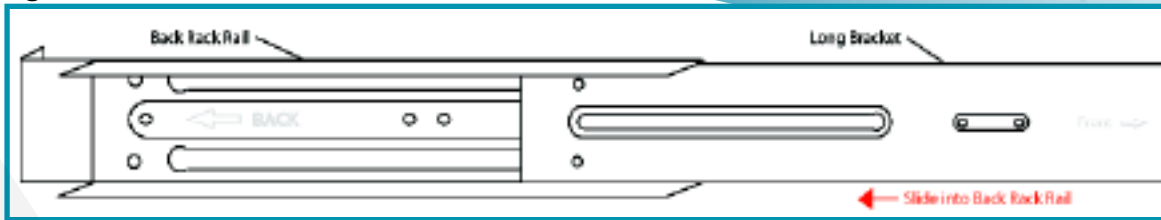

2. Slide the long bracket until it is flush against the end of the back rack rail. This enables you to push the peg on the back rail into the groove on the long bracket.
3. Arrange the back rail so it fits snugly against one of the rack columns. The grooves in the back rack rail and the long bracket should be pointing in towards the rack columns on the other side.
4. Take one of the short brackets and position it so it is flush against the backside of the long bracket.
5. Slide the short bracket until it is flush against the back of the front rack column as shown in **Figure 7-10**.

Figure 7-10

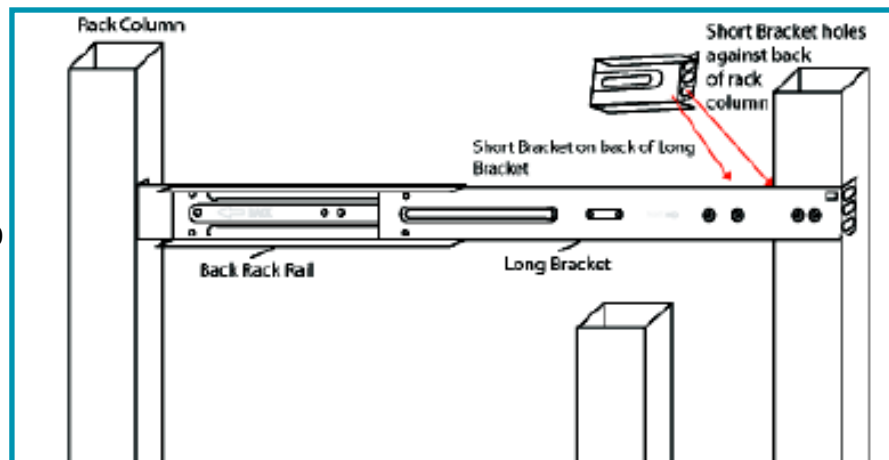

6. When you have sized the rail and brackets, secure them using the panhead screws.
7. Secure the short bracket to the long bracket using one panhead screw through the groove in the short bracket and through the threaded hole. Attach the short bracket so that the head of the panhead screw is on the backside of the long bracket.
8. Secure the long bracket inside the back rack rail with a panhead screw using one of the threaded holes on the grooved side of the back rack rail.
9. Now attach the combined long bracket, back rack rail, and short bracket (outer slide assembly) to the rack columns using flathead screws. It is recommended that you use two screws for each.
10. Repeat these steps for the other side.

Install the HCI000 Series Nodes into the Rack

Push the slides of the node into the grooves of the outer slide assemblies in the rack. Push the node all the way back until it is flush in the rack. Repeat for each node.

Install the HC2000 and HC4000 Series Nodes into the Rack

The HC2000 and HC4000 series nodes come largely pre-configured for a simple click-and-go rack installation.

1. Locate the front of each rail, labeled as such.
2. Orient each end piece to seat in the holes on the front side of your rack
3. Align each end piece in the bottom and top holes of the desired rack space and ensure the latch clicks into place before proceeding further.
4. Repeat **Step 1 to Step 3** for the back of each rail. The completed process will be similar to **Figure 7-11** for each node's rack rails.

Figure 7-11

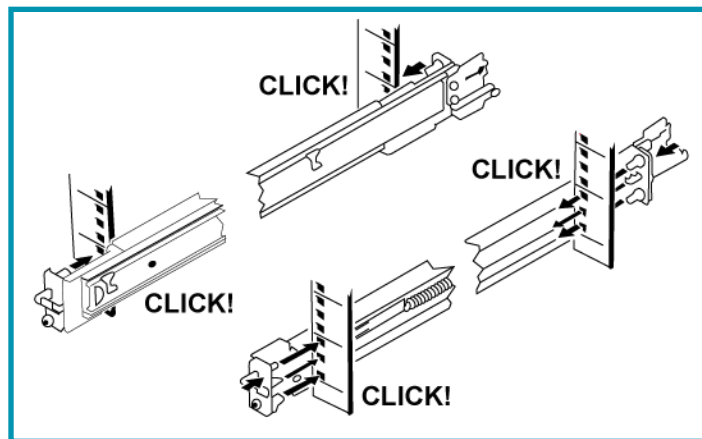

5. Pull the inner slide rails out of the rack until they lock into place, as seen in **Figure 7-12**.

Figure 7-12

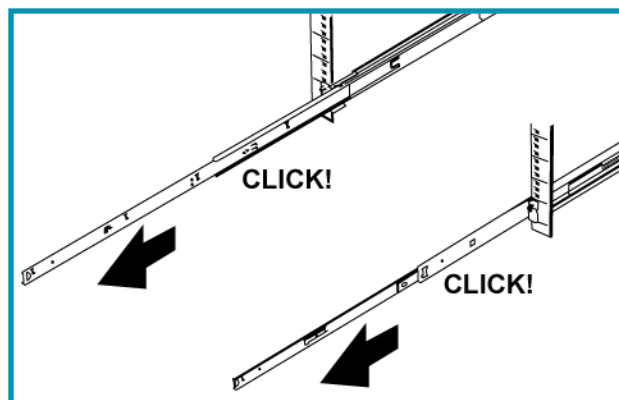

6. Locate the rear rail pins on each side of the system and lower them into the rear slots on the slide rails.
7. Rotate the system down until all the rail pins on the chassis are seated in the corresponding slots, as seen in **Figure 7-13**.

Figure 7-13

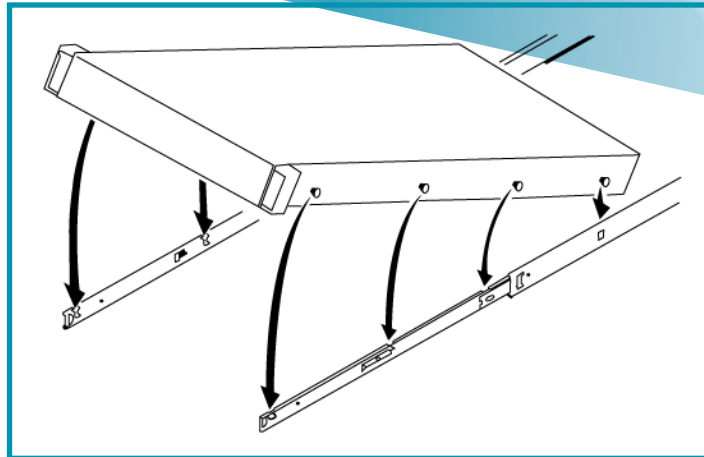

8. Push the chassis inward until the lock levers click into place, step one of **Figure 7-14**.
9. Press the slide-release lock button on both rails and slide the chassis into the rack. Step two of **Figure 7-14**.

Figure 7-14

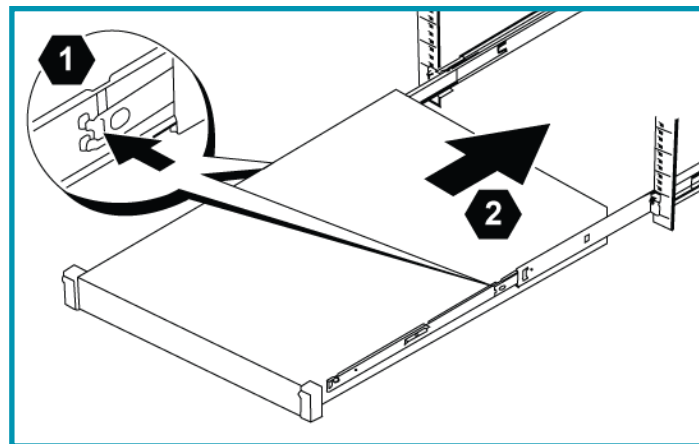

Cable the Nodes

After you install the nodes in the rack, connect the nodes to their designated power outlets per Scale's best practices.

Connect the proper network cables to the nodes. Each node will have two ports labeled for LAN and two ports labeled for backplane. Follow Scale's best practices for network performance, switch setup, and high availability (HA) configuration.

8

Node and Cluster Configuration

Making a cluster

Prior to configuring the individual nodes, be sure to verify network and cabling setup has been completed. The Scale configuration software confirms connectivity between nodes during IP configuration, as well as the ability to connect to a gateway before allowing node configuration to continue.

In order to configure your cluster, you must have serial or graphical console access to the physical nodes. Serial access is VT100 at 115,200 baud. Any standard VGA monitor and USB keyboard also work as a graphical console.

The following topics are included in this chapter:

- **Configuration Checklist**
- **Configure and Initialize the Nodes**

Configuration Checklist

Ensure all cables, cords, and switches are setup correctly before configuring the nodes. The following is a check list to verify before beginning:

- Review this guide
- Double check the network information and IPs
- Verify you meet all of the pre-installation requirements
- Ensure the cluster nodes are set up in the same room, with all components next to one another
- Ensure you have connected everything and your equipment (switches, cables, UPS) are appropriate for your Scale cluster hardware
- Ensure you can access all of the documents you may need to reference during installation
- Have a monitor and keyboard ready and available

Configure and Initialize the Nodes*

All installations should be scheduled at least 24 hours in advance. The installation specialist assisting you will provide the necessary credentials during the scheduled installation time.

NOTE: It is now possible to deploy a Single Node Appliance Configuration. The commands provided below are applicable to a single node or multiple node installation. For a single node installation, proceed through Steps 1 to 4, and then skip to Steps 9 to 11 to complete the installation.

All configuration of the nodes is done from the command line using a monitor and keyboard. Clusters are configured in a top-to-bottom configuration, with the top node in the rack being the designated “first” node.

1. Hook the monitor and keyboard to the top node in the cluster. Log in to the node using the provided credentials.

* See the Single Node Appliance Configuration Note for proper installation steps.

2. Run the command to begin node configuration: `sudo scnodeinit`
3. You will be prompted for each piece of IP and network information. Once the **LAN IP**, **LAN Netmask**, **LAN Gateway**, **Backplane IP of this node**, and **Backplane IP of first node in cluster** (which will be the same as **Backplane IP of this node** on the first node) are filled out, the node will run diagnostic checks to confirm the IPs are valid, available on the network, and the gateway is pingable. See *Figure 8-1* for an example of the first node's IP configuration. See **Figure 8-2** for the full IP verification process.

Figure 8-1

```
LAN IP: 10.205.13.30
LAN Netmask: 255.255.255.0
LAN Gateway: 10.205.13.1
Backplane IP of this node: 172.16.15.1
Backplane IP of first node in cluster: 172.16.15.1
```

- 4a. If you are utilizing the **Single Node Appliance Configuration**, run the command to initialize the single node: `sudo singleNodeCluster=1 scclusterinit`
- 4b. If you are utilizing the cluster configuration, run the command to prepare for cluster initialization on the first node once the first node's IP configuration is complete: `sudo scclusterinit`
5. Configured nodes will appear in the display list as they are configured and verified.
- 6a. If you are utilizing the **Single Node Appliance Configuration**, skip to **Step 9**.
- 6b. If you are utilizing the cluster configuration, move the monitor and keyboard to the next node down. Use the same steps, **Step 2** and **Step 3**, to configure the node. See **Figure 8-2** for the example configuration of subsequent nodes as well as the full IP verification process.

Figure 8-2

```
LAN IP: 10.205.13.31
LAN Netmask: 255.255.255.0
LAN Gateway: 10.205.13.1
Backplane IP of this node: 172.16.15.2
Backplane IP of first node in cluster: 172.16.15.1
Checking parameters. Complete
Checking LAN IP and initializing node for conflicts/availability. Complete
Verifying gateway. Complete
Setting up local networking. Complete
Checking initializing node and gateway after network restart. Complete
Waiting for hardware to complete node initialization. Complete
```

7. Continue the node configuration process for the remaining nodes in the cluster using **Step 2** to **Step 3**.
8. Once all nodes have been configured, return to node one (the top node in the cluster).
9. Verify all nodes that were configured are displayed on the list for cluster initialization, as seen in **Figure 8-3**. If utilizing the **Single Node Appliance Configuration**, only the single node will be shown. When all nodes are shown, follow the prompt and enter **Yes** to complete the cluster initialization as seen in **Figure 8-4**.

Figure 8-3

```
Waiting for nodes. Press ctrl-C to exit or when all nodes intended for this cluster are shown below:
New node: 10.205.13.32
New node: 10.205.13.31
```

Figure 8-4

```
Nodes ready for induction into the cluster:
New node: 10.205.13.32
New node: 10.205.13.31
Enter 'yes' to confirm: █
```

10. It will take approximately 15-20 minutes for the node(s) to initialize. Once complete the HC3 web interface will be accessible using the configured LAN IP of the node(s).
11. Review the [Scale Computing User Guide](#) for your applicable firmware for information on first time configuration tasks in the HC3 web interface.