



# Switched PRO2

**User Guide**

Firmware 8.0



### Instructions

This symbol is intended to alert the user to the presence of important operating and maintenance (servicing) instructions in the literature accompanying the appliance.



### Dangerous Voltage

This symbol is intended to alert the user to the presence of un-insulated dangerous voltage within the product's enclosure that may be of sufficient magnitude to constitute a risk of electric shock to persons.



### Protective Grounding Terminal

This symbol indicates a terminal that must be connected to earth ground prior to making any other connections to the equipment.

### Life-Support Policy

As a general policy, Server Technology® does not recommend the use of any of its products in the following situations:

- life-support applications where failure or malfunction of the Server Technology product can be reasonably expected to cause failure of the life-support device or to significantly affect its safety or effectiveness.
- direct patient care.

Server Technology will not knowingly sell its products for use in such applications unless it receives in writing assurances satisfactory to Server Technology that:

- the risks of injury or damage have been minimized,
- the customer assumes all such risks, and
- the liability of Server Technology is adequately protected under the circumstances.

The term life-support device includes but is not limited to neonatal oxygen analyzers, nerve stimulators (whether used for anesthesia, pain relief or other purposes), auto-transfusion devices, blood pumps, defibrillators, arrhythmia detectors and alarms, pacemakers, hemodialysis systems, peritoneal dialysis systems, neonatal ventilator incubators, ventilators (for adults or infants), anesthesia ventilators, infusion pumps, and any other devices designated as "critical" by the U.S. FDA.

### Notices

301-9999-30 Rev E (102816)

Copyright © 2005-2016 Server Technology, Inc. All rights reserved.

1040 Sandhill Drive

Reno, Nevada 89521 USA

### All Rights Reserved

This publication is protected by copyright and all rights are reserved. No part of it may be reproduced or transmitted by any means or in any form, without prior consent in writing from Server Technology.

The information in this document has been carefully checked and is believed to be accurate. However, changes are made periodically. These changes are incorporated in newer publication editions. Server Technology may improve and/or change products described in this publication at any time. Due to continuing system improvements, Server Technology is not responsible for inaccurate information which may appear in this manual. For the latest product updates, consult the Server Technology web site at [www.servertech.com](http://www.servertech.com). In no event will Server Technology be liable for direct, indirect, special, exemplary, incidental, or consequential damages resulting from any defect or omission in this document, even if advised of the possibility of such damages.

In the interest of continued product development, Server Technology reserves the right to make improvements in this document and the products it describes at any time, without notices or obligation.

The Globe logo is a trademark of Server Technology, Inc., registered in the US. Use of the logos for commercial purposes without the prior written consent of Server Technology may constitute trademark infringement and unfair competition in violation of federal and state laws.

Server Technology, the Globe logo, Sentry, Switched CDU, CDU, PRO2, PIPS, POPS, PDU Power Pivot, and StartUp Stick are trademarks of Server Technology, Inc., registered in the US. EZip is a trademark of Server Technology.

Other trademarks and trade names may be used in this document to refer to either the entities claiming the marks and names or their products. Server Technology, Inc. disclaims any proprietary interest in trademarks and trade names other than its own.



### Please Recycle

Shipping materials are recyclable. Please save them for later use, or dispose of them appropriately.

# Table of Contents

<b>Chapter 1: Introducing the PRO2</b>	<b>5</b>
Welcome to the Server Technology <sup>®</sup> Switched PRO2 .....	5
What's the PRO1? .....	6
About Your User Guide .....	7
PDU Power Pivot <sup>®</sup> .....	7
Star Linking Technology .....	8
Unit Persistence .....	9
Additional PRO2 Resources .....	9
Contact Technical Support .....	10
Equipment Overview .....	11
<b>Chapter 2: Installing the PRO2</b>	<b>12</b>
Standard Accessories .....	12
Optional Accessories .....	12
Additional Required Items .....	12
Safety Precautions .....	13
Input Power Cord Retention Options for PRO2s with IEC C20 Inlets .....	14
Attaching Safety Earth Ground Connection .....	15
Mounting the PRO2 Unit .....	16
<b>Chapter 3: Getting Started with the Firmware</b>	<b>19</b>
On-Board File System .....	19
Intuitive and Consistent Terminology .....	19
Outlet Grouping .....	19
Setting Thresholds .....	19
PRO2 Dashboard View .....	20
The User Interfaces .....	21
Usernames and Passwords .....	21
User Access Rights .....	22
IPv4/IPv6 Support .....	23
<b>Chapter 4: Using the Web Interface</b>	<b>26</b>
Logging In .....	26
Quick Tour of the GUI .....	26
Overview (Viewing the System Dashboard) .....	30
Monitoring (Analyzing Metrics) .....	34
Control (Managing Outlets) .....	48
Configuration (Setting Values) .....	52
Network (Setting Up Network Protocols) .....	92
Access (Managing Users) .....	113
Tools (Using Support Functions) .....	122

<b>Chapter 5: Using the Command Line Interface (CLI)</b>	<b>130</b>
Logging In .....	130
Quick Tour of the Command Line .....	130
List of Commands .....	133
Command Details .....	139
<b>Appendix A: Product Support Information</b>	<b>204</b>
LED Indicators .....	204
Branch Circuit Protection .....	205
Circuit Breaker .....	205
Compact Fuse Holder .....	206
Fuse Retractor, Fuse Access Window, and Fuse Access Cover.....	207
Time-Delay Fuses – Class G .....	208
PROx Network Interface Card (NIC) Swap .....	209
<b>Appendix B: Regulatory Compliance</b>	<b>210</b>
Product Safety .....	210
Notifications .....	210
Product Recycling .....	211
<b>Appendix C: Product Warranty–Technical Support–RMA</b>	<b>212</b>
Warranty .....	212
Contact Technical Support .....	212
Return Merchandise Authorization (RMA) .....	212

# Chapter 1: Introducing the PRO2

## Welcome to the Server Technology® Switched PRO2

The Switched PRO2 is the latest design in Server Technology's reliable power distribution units, providing flexibility for future power management, cost savings, and advanced solutions for data center customers.



### Key Product Features

The Switched PRO2 offers many features for the next generation of power management, including:

- PIPS® and (optionally) POPS® high-accuracy measurements for current, voltage, power, and other key metrics. PIPS is a standard feature on all PRO2 units.
- Auto-Flip LED display gives the proper display orientation no matter how the PRO2 is mounted in the cabinet.
- Outlet naming on all PRO2 products (for both Switched and Smart products).
- Hot-swappable network interface card (NIC) allows swapping the card in the field without causing a change in outlet state. The NIC can easily be replaced even when power is applied.
- Support for IPv6 address names and support for SNMPv3.
- Equipped for the mobile power monitoring solution using a Bluetooth® module (for either Google Android or Apple iOS), along with Server Technology's ST Eye mobile application.
- Branch current measurements on both Switched and Smart PRO2 products, and notification of fuse or breaker failure.
- Several new levels of power monitoring for high-low warning-alarm thresholds and threshold hysteresis.
- If the master unit loses power, redundant power is provided to the master via the first linked unit, ensuring uptime.
- On-board firmware file system to allow direct GUI downloads of system files, firmware version updates, and MIB/OID tree files without using FTP.
- Intuitive and soft-mapped naming conventions used in both the PRO2 hardware and firmware to reflect the system hierarchy of units, cords, lines, phases, over-current protectors (OCPs), branches, outlets, outlet groups, and sensors.

## What's the PRO1?

Like the PRO2, the PRO1 (Switched and Smart) is another new PDU design from Server Technology to provide the same type of flexibility for power management, cost savings, and advanced data center solutions that the PRO2 delivers.

### What's Unique About the PRO1?

Server Technology's PRO1 design allows for PRO2 functionality in a CDU1 form factor.

The PRO1 uses the Sentry4-MIB and the PRO2 firmware, version 8.0.x, allowing PRO1 products to offer the latest features and functions of the PRO2 product family.



Equipment View of the PRO1 Unit

### Feature Comparison: PRO1 vs. PRO2

The PRO1 is similar to the PRO2 in hardware architecture, object mapping, user interfaces (GUI and CLI), firmware (version 8.0.x or later), and new Sentry4-MIB, but the PRO1 **does not** include the following PRO2 items:

- Branch Current Monitoring feature
- TRMS Current Input Monitoring (in some cases rather than PIPS)

The following table shows a detailed benefit comparison:

Product	Benefits
PRO1	<b>CDU with the NIM2/PRO2 network card:</b> <ul style="list-style-type: none"><li>• Faster processor and more memory</li><li>• Hot swap network card</li><li>• Network card swap with no re-programming (PCM)</li><li>• Features/functions can be added as needed</li><li>• Multi-linking (up to 4 units)</li><li>• Power from link unit keeps network up if power from master unit goes down</li><li>• Sentry4-MIB allows additional alarm warning and threshold levels</li></ul>
PRO2	<b>PRO2 architecture with the NIM2 network card:</b> <ul style="list-style-type: none"><li>• PRO1 features, plus additional features</li><li>• PIPS standard</li><li>• Branch monitoring standard</li><li>• Locking data and low voltage cables</li><li>• Smart products with breaker/fuse branch circuit sensing</li><li>• All products 60 degrees Celsius rated</li></ul>

## About Your User Guide

This user guide was designed for data center personnel who monitor power, control outlet actions, and administer equipment operations in the data center network using Server Technology's firmware, version 8.0x or later, on the PRO2 product family.

Your guide provides installation, connection, and mounting instructions for the PRO2 product in the equipment cabinet and illustrates the PRO2's key features in a hardware overview.

Also provided is task-based information for working with the firmware. Step-by-step instructions are presented for daily operational tasks on the PRO2 when using the firmware Web Interface, including GUI screen samples for each function. If CLI is preferred, a separate chapter provides detailed command syntax and usage for every command that can be issued on the PRO2.

## PDU Power Pivot®

Server Technology's PDU Power Pivot® flexible infeed provides a simplified power cord routing to the PRO2 unit with a design that eliminates bend radius issues.

As illustrated below, the PDU Power Pivot capability can deliver a solution for several types of PDU installations and mountings, setting the correct cord angle for overhead power, offset overhead power, concrete floor, raised floor, and intra-rack power.

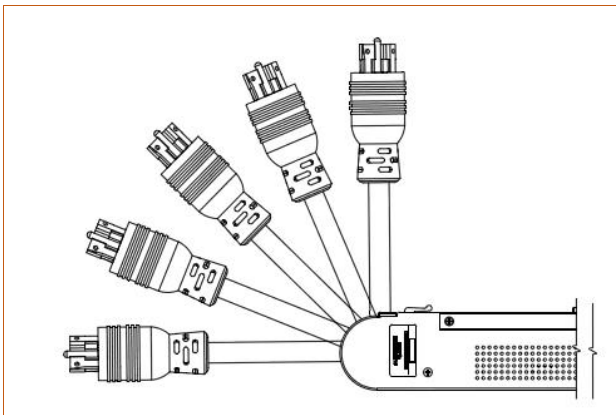

**PDU Power Pivot – Flexible Cord Design**

## Star Linking Technology

Server Technology's PRO2 introduces Star Linking technology that supports the optional linking of up to three expansion (link) units per one PRO2 master unit, allowing a single IP address for multiple cabinets.



**Note:** The Star Linking feature is available only with PRO2 products.

The following illustrations show multi-linking between separate units and within the cabinet:

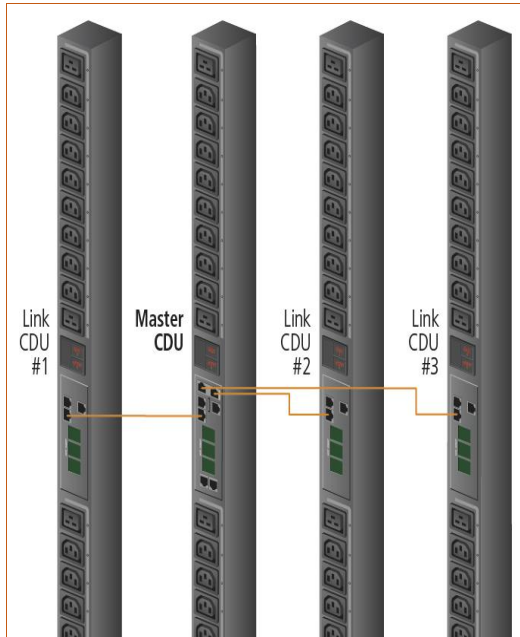

**Multi-Linked PRO2 Units**



**Multi-Linking View in the Equipment Cabinet**

### **Redundant Power and Communication**

The Star Linking arrangement is fault tolerant, with redundant power coming from the first link unit. The arrangement also offers significant cost reduction as the link units do not require a network card.

Another significant advantage of Star Linking technology is that if power in the master unit is lost, communication will continue with the other link units – a major improvement over a daisy chain linking configuration.

### **Outlet Grouping**

The multi-linking arrangement allows outlet grouping across the master and three link units.

### **Cable Length**

The maximum cable length allowed from link unit to master unit is 21-feet.

### **Multi-Linking Module**

In the Star Linking arrangement, the first PRO2 link unit connects via the PRO2 link port. However, the second and third link units in the multi-linking arrangement attach to an optional T-shaped module that connects to the Bluetooth® port on the PRO2 master unit, while still allowing full functionality for Bluetooth® mobile power monitoring.



The module and its connection are illustrated as follows:

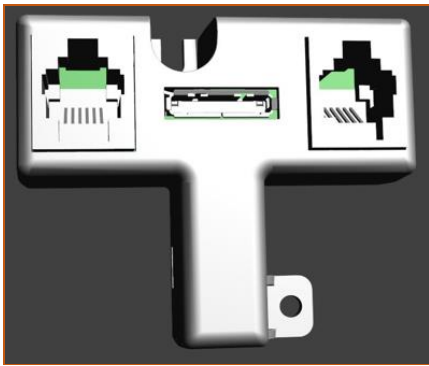

**Multi-Linking Module**



**Connection to Bluetooth® Module Port**

### ***Getting Started***

The optional Star Linking feature is sold as a separate kit purchased from Server Technology. To use the feature, contact your sales representative to order the **PRO2 Multi-Linking Module Kit**, part number **KIT-PRO2LINK-01M**.

The kit contains:

- 1 link module (labeled to show the 2<sup>nd</sup> and 3<sup>rd</sup> link unit)
- 2 linking cables, (21 ft.) 6.4 m

## **Unit Persistence**

Unit Persistence is an internal PRO2 feature that works as follows:

If a link unit is connected to a master unit, and the link unit is disconnected (powered down or accidentally disconnected), and the master unit is restarted, the link unit will be reported as “Not Found” after the restart because the link unit is no longer physically connected to the master.

However, the association between the master/link units is retained to allow the continuation of alerts. If the disconnected link unit is physically re-connected to the master, the “Not Found” status will return to “Normal” status.

To intentionally remove a link unit from connection with a master unit, the link unit must be purged using the Purge function.

Unit persistence affects **all connected PRO2 master/link units** whether or not they are connected in a multi-linking configuration.

## **Additional PRO2 Resources**

For more information about the PRO2, including available product models and an introductory product video, see Server Technology’s Uptime Solutions page:

<http://www.servertech.com/solutions/uptime-solutions>

## Contact Technical Support



### Experience Server Technology's **FREE** Technical Support

Server Technology understands that there are often questions when installing and/or using a new product. Free Technical Support is provided from 8 a.m. to 5 p.m. PST, Monday through Friday. After-hours service is provided to ensure your requests are handled quickly no matter what time zone or country you are located in.

Server Technology, Inc.

1040 Sandhill Drive

Tel: 1-800-835-1515

Web: [www.servertech.com](http://www.servertech.com)

Reno, Nevada 89521 USA

Fax: 775-284-2065

Email: [support@servertech.com](mailto:support@servertech.com)

## Equipment Overview

The following illustration highlights the key operational areas of the Switched PRO2 unit:

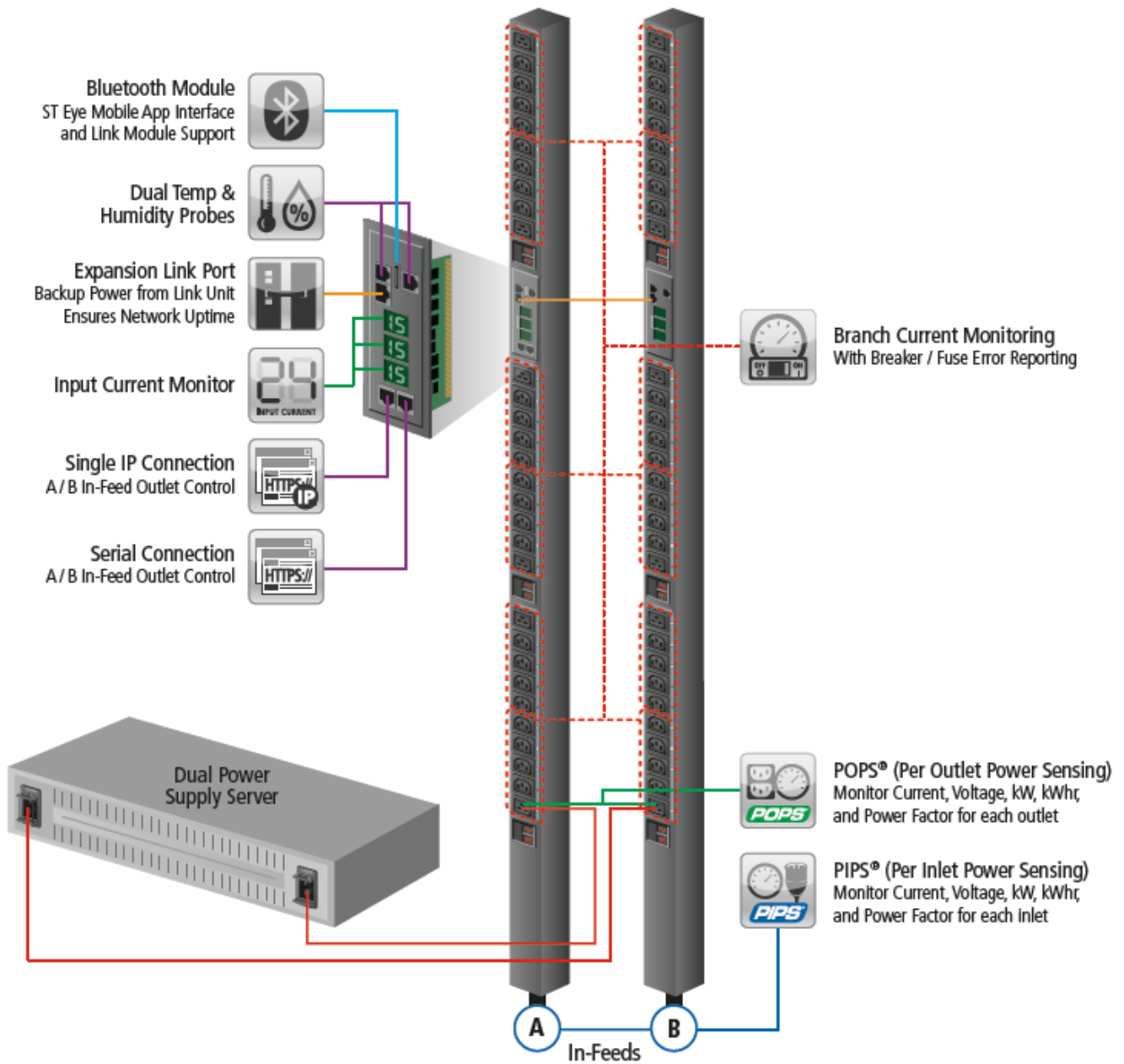

Switched PRO2 – Equipment Overview

## Chapter 2: Installing the PRO2

Before installing your Switched PRO2 unit, look over the following lists to make sure you have all the items shipped with the unit, as well as any other items needed for proper installation.

### Standard Accessories

#### *Mounting Hardware*

- Vertical Models: Two mounting buttons with two M4 (10 mm) screws.
- Horizontal Models: Two removable L-brackets with four M4 screws (for 1U models), or M5 screws (for 2U models).

#### *Cables/Adapters*

- For C2L, C2LG, C2X, C2XG, or SEV models – link cables (6P6C connectors).
- Link units are shipped with a 7-inch link cable and a 14-foot link cable.

#### *Additional Items*

- Units with IEC C20 power inlets: input power cords (ordered separately).

### Optional Accessories













- Star-Link Module Kit (Part No. KIT-PRO2LINK-01M).
- Temperature/Humidity Sensors (Part No. EMTH-1-1).
- Environmental Monitor (Part No. EMCU-1-1B).
- Water Sensor (Part No. EMWS-1-1, used with EMCU-1-1B).
- Vertical mounting brackets; additional mounting options are available in the Accessories section of [www.servotech.com](http://www.servotech.com).

### Additional Required Items

- Flathead and Phillip screwdrivers.
- Screws, washers, and nuts to attach the PRO2 unit to your equipment rack.

## Safety Precautions

This section contains important safety and regulatory information that **must be reviewed** before installing and using the Switched PRO2.

	Only for installation and use in a Restricted Access Location in accordance with the following installation and use instructions.  <b>This equipment should only be installed by trained personnel.</b>	Destiné à l'installation et l'utilisation dans le cadre de Restricted Access Location selon les instructions d'installation et d'utilisation.  <b>Cet équipement est uniquement destiné à être installé par personnel qualifié.</b>	Nur für Installation und Gebrauch in eingeschränkten Betriebszonen gemäß der folgenden Installations- und Gebrauchsanweisungen.  <b>Dieses Gerät ist nur für den Einbau durch Personal vorgesehen.</b>
	This equipment is designed to be installed on a dedicated circuit. The power supply cord shall be a minimum of 1.5m (4.9ft) and a maximum of 4.5m (15ft). If using an extension power cord, the total length shall also be no more than the maximum allowed. The plug is considered the disconnect device and must be easily accessible.	Cet équipement a été conçu pour être installé que un circuit dédié. Le cordon d'alimentation doit être d'au moins 1,5M et un maximum de 4,5m. Si vous utilisez un cordon de rallonge, la longueur totale est également plus que le maximum autorise. La prise est considérée comme un dispositif de coupure et doit être facilement accessible.	Die Geräte sind für eine Installation an einer fest zugeordneten Leitung ausgelegt. Die Stromzuleitung hat eine Mindestlänge von 1,5m, und höchstens 4,5m. Sollten Sie ein Verlängerungskabel, der Gesamtänge auch nicht mehr als die maximal zulässige sein. Der Stecker dient zur Trennung vom Netz und muss einfach erreichbar sein.
	The dedicated circuit must have circuit breaker or fuse protection. PDUs have been designed without a master circuit breaker or fuse to avoid becoming a single point of failure. It is the customer's responsibility to provide adequate protection for the dedicated power circuit. Protection of capacity equal to the current rating of the PDU must be provided and must meet all applicable codes and regulations. In North America, protection must have a 10,000A interrupt capacity.	Le circuit spécialisé doit avoir un disjoncteur ou une protection de fusible. PDUs ont été conçus sans disjoncteur général ni fusible pour éviter que cela devient un seul endroit de panne. C'est la responsabilité du client de fournir une protection adéquate pour le circuit-alimentation spécialisé. Protection de capacité équivalent à la puissance de l'équipement, et respectant tous les codes et normes applicables. Les disjoncteurs ou fusibles destinés à l'installation en Amérique du Nord doivent avoir une capacité d'interruption de 10.000 A.	Der feste Stromkreis muss mit einem Schutzschalter oder einem Sicherungsschutz versehen sein. PDUs verfügt über keinen Hauptschutzschalter bzw. über keine Sicherung, damit kein einzelner Fehlerpunkt entstehen kann. Der Kunde ist dafür verantwortlich, den Stromkreis sachgemäß zu schützen. Der Kapazitätsschutz entspricht der aktuellen Stromstärke der Geräte und muss alle relevanten Codes und Bestimmungen erfüllen. Für Installation in Nordamerika müssen Ausschalter bzw. Sicherung über 10.000 A Unterbrechungskapazität verfügen.
	Models with unterminated power cords: Input connector must be installed by qualified service personnel. Input connector rating must meet all applicable codes and regulations.	Modèles avec cordons d'alimentation non terminées: Le connecteur d'entrée doit être installé par un personnel qualifié. Entrée cote de raccordement doit respecter tous les codes et règlements électriques applicables.	Modelle mit nicht abgeschlossenen Netzkabel: Der Eingangsstecker darf nur von qualifiziertem Wartungspersonal installiert werden. Eingangsanschluss Bewertung müssen alle geltenden und verbindlichen Normen und Vorschriften entsprechen.
	Do not block venting holes when installing this product. Allow for maximum airflow at all times.	Ne bloquez pas les orifices d'aération lors de l'installation de ce produit. Permettre une circulation d'air maximale à tout moment.	Achten Sie darauf, dass keine Belüftungslöcher bei der Installation dieses Produkts. Damit für maximalen Luftstrom zu allen Zeiten.
	Installation Orientation: Vertical units are designed to be installed in vertical orientation.	Installation Orientation: Les unités vertical sont conçues pour être installées dans une orientation verticale.	Installationsausrichtung: Vertical Einheiten sind zur vertikalen Installation vorgesehen.
 	Always disconnect the power supply cord before servicing to avoid electrical shock. For products with two input power cords, both must be disconnected before servicing.	Toujours débrancher le cordon d'alimentation avant de l'ouverture pour éviter un choc électrique. Pour les produits avec deux cordons d'alimentation d'entrée, les deux doivent être déconnectés avant l'entretien.	Trennen Sie das Netzkabel, bevor Sie Wartungsarbeiten Öffnung einen elektrischen Schlag zu vermeiden. Für Produkte mit zwei Eingangsstromkabel, sowohl, müssen vor der Wartung abgeschaltet werden.
	<b>WARNING!</b> High leakage current! Earth connection is essential before connecting supply!	<b>ATTENTION!</b> Haut fuite très possible! Une connection de masse est essentielle avant de connecter l'alimentation !	<b>ACHTUNG!</b> Hoher Ableitstrom! Ein Erdungsanschluss ist vor dem Einschalten der Stromzufuhr erforderlich!
 	<b>WARNING!</b> Cx-xxE-x units double pole/neutral fusing	<b>ATTENTION!</b> Les unités Cx-xxE-x Double Pôle/Fusible sur le Neutre	<b>ACHTUNG!</b> Cx-xxE-x Zweipolige bzw. Neutralleiter-Sicherung
	<b>ATTENTION!</b> Observe precautions for handling Electrostatic Sensitive Devices.	Attention ! Respecter les mesures de sécurité en manipulant des dispositifs sensibles aux décharges électrostatiques.	Achtung! Vorsichtshinweise zur Handhabung elektrostatisch empfindlicher Geräte beachten.
	Products rated for 240/415VAC may be fitted with a plug that is rated for a higher voltage. Caution must be taken to assure that the rating of the unit and the supply voltage match.	Les produits prévus pour 240/415VAC peut être équipé d'un bouchon qui est conçu pour une tension plus élevée. Des précautions doivent être prises pour assurer que la cote de l'unité et la tension d'alimentation correspond.	Produkte die für 240/415VAC zugelassen sind können mit einem Stecker der für eine höhere Spannung ausgestattet sein. Vorsicht ist geboten, um sicherzustellen, dass die erlaubten Betriebswerte des Gerätes und der Versorgungsspannung zueinander passen.

## Input Power Cord Retention Options for PRO2s with IEC C20 Inlets

Determine which Detachable Input Cord was supplied with your PRO2 unit:

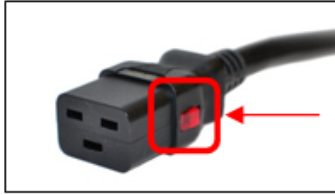

**For the following Detachable Input Cords with the self-locking IEC C19 feature, follow Procedure A below.**

PTCORD-L1, PTCORD-L2, PTCORD-L3, PTCORD-L5, PTCORD-L6, or PTCORD-L7.



**For the following Detachable Input Cords, follow Procedure B below.**

PTCORD-1, PTCORD-2, PTCORD-3, PTCORD-4, PTCORD-5, PTCORD-6, or PTCORD-7.

### **Procedure A**

If the PRO2 was supplied with a Detachable Input Power Cord with a self-locking IEC C19, install it directly into the C20 inlet.

1. Verify the Retention Bracket Assembly (part number KIT-0016) is not installed.
  - a. If KIT-0016 is installed, remove the two screws attaching the bracket to the IEC 60320 C20 inlet to the enclosure.
  - b. Remove the Retention Bracket Assembly.
  - c. Re-attach the two screws to the IEC C20 and securely tighten.
2. Push the C19 from the Detachable Input Cord firmly into the C20 inlet to ensure it is properly seated.

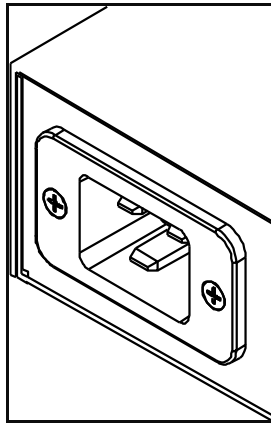

**C20 Inlet Without Retention Bracket Assembly**

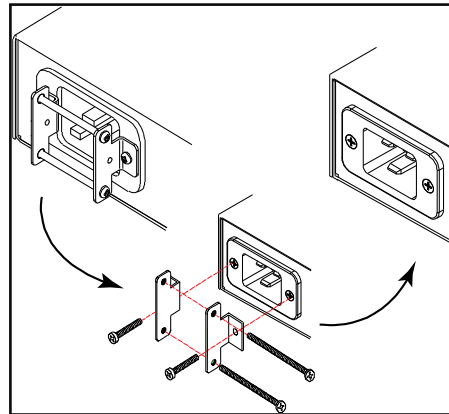

**KIT-0016 Retention Bracket Assembly**

### **Procedure B**

If the PRO2 was supplied with a Detachable Input Power Cord without the self-locking C19 feature, install with the Retention Bracket Assembly (part number KIT-0016), followed by the power cord.

1. Remove the two screws attaching the IEC 60320 C20 inlet to the enclosure.
2. Assemble and attach the Retention Bracket to the enclosure as shown
3. Connect the power cord. Ensure the C19 is fully seated against the C20 inlet. (It may be necessary to loosen some of the Retention Bracket Assembly screws to allow the C19 plug to be properly installed.)
4. Tighten the Retention Bracket Assembly to restrain the power cord.

## Attaching Safety Earth Ground Connection

Server Technology PDUs are supplied with an external safety ground connection to provide an alternate ground path for fault currents, and to maintain the same ground reference between it and the equipment rack.

---

**NOTE:** The auxiliary external ground location may vary. Most PDUs will have it located near the power cord entry located near the  symbol.

**User-supplied materials:**

- One 5 mm internal (or external) tooth star washer;
- One 4.0 mm<sup>2</sup> (10 AWG) wire with 5 mm ring terminal;
- One metric M5 x 6 mm coarse pitch screw.

**Instructions:**

1. Connect one end of the ground wire to the equipment cabinet or local ground.
2. Locate the PDU external ground near the  symbol.
3. Connect the other end with a ring terminal and a M5 screw to the PDU external ground. To ensure proper grounding to the chassis, use a star washer between the ring terminal and the PDU.

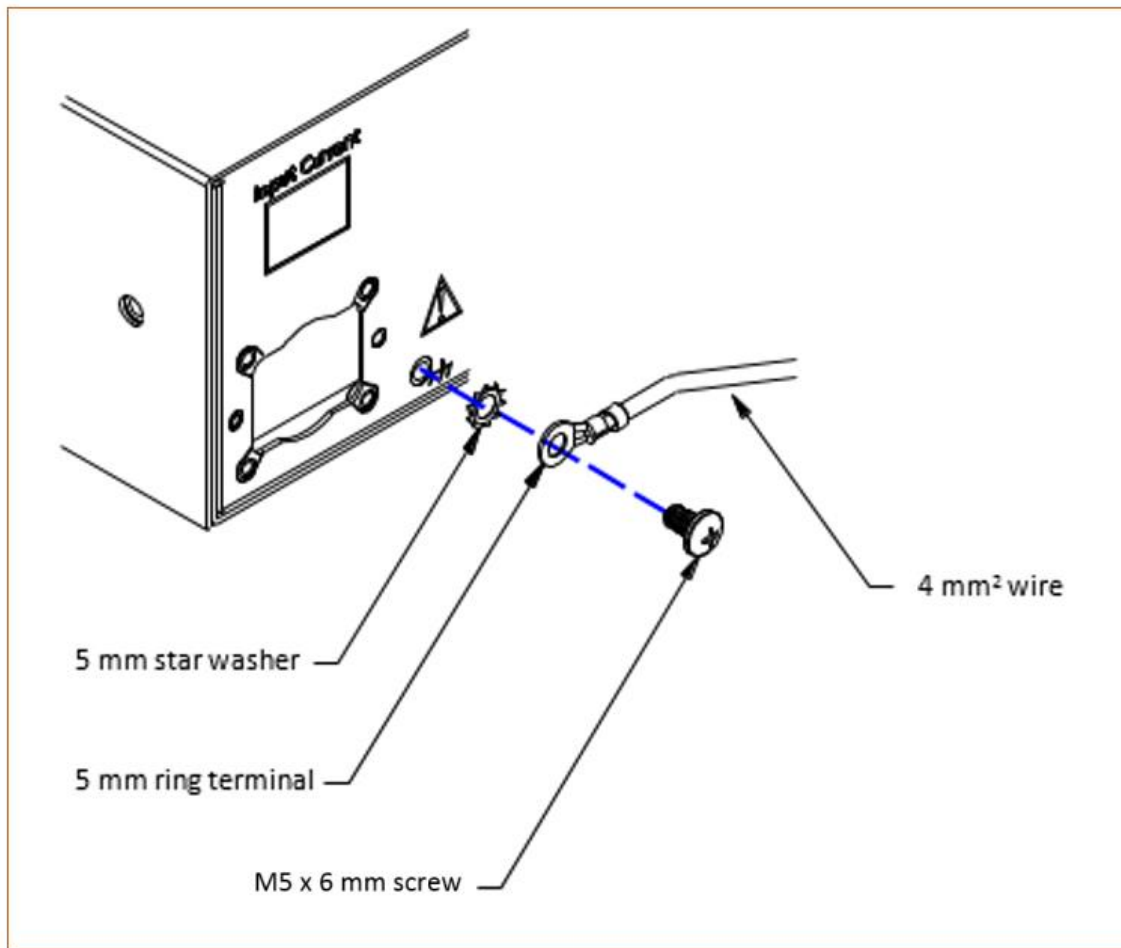

## Mounting the PRO2 Unit

The following illustration shows how to mount the PRO2 unit in vertical or horizontal orientation:

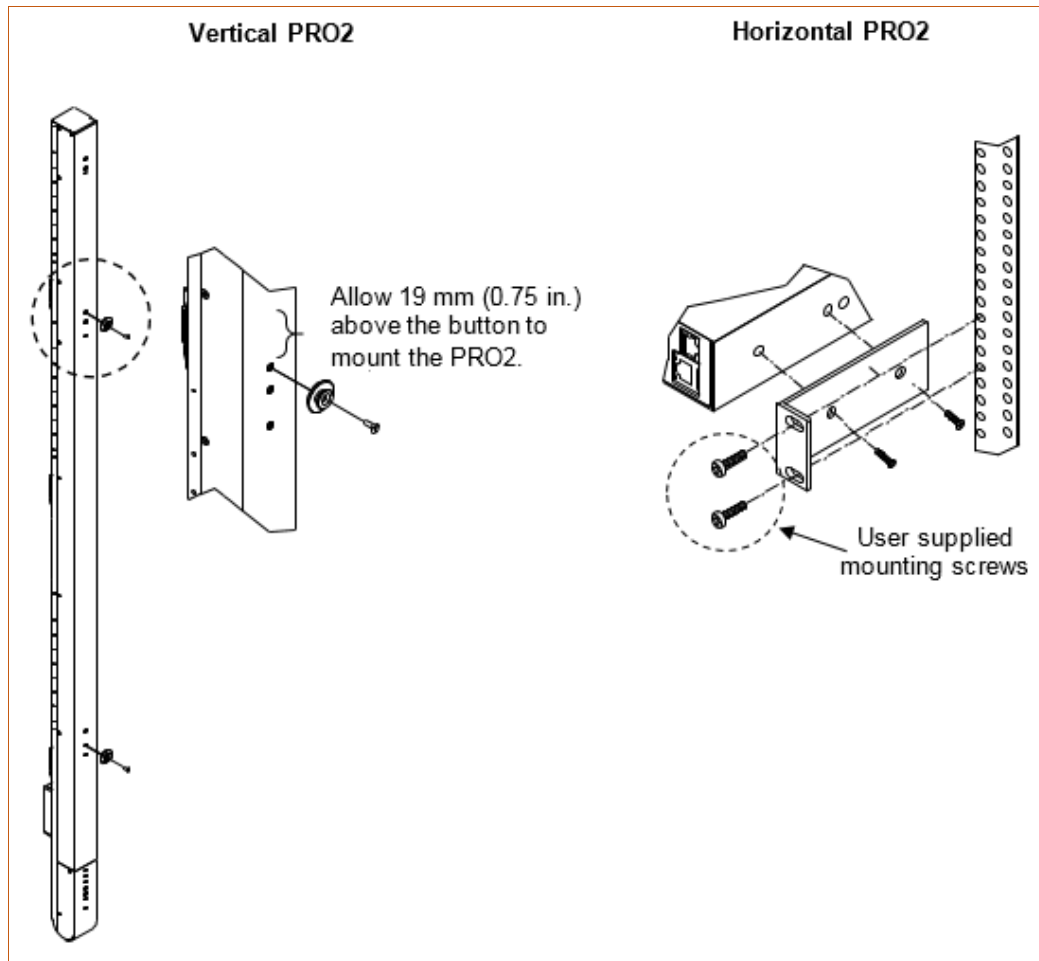

### Horizontal/Rack

1. Select the appropriate bracket mounting points for proper mounting depth within the rack.
2. Attach the L-brackets to these mounting points with two screws for each bracket.
3. Install the enclosure into your rack, using the slots in each bracket. The slots allow about 6 mm (0.25 inch) of horizontal adaptability to align with the mounting holes of your rack.

### Vertical

PRO2 units are supplied with button mounting kit(s). Distribute the buttons vertically and attach to the PRO2 as appropriate for the cabinet. An additional 19 mm (0.75 inch) of clearance is required at the top of the PRO2 to allow the button to mount into the keyholes.



**Note:** For more information about horizontal/vertical mounting options for the PRO2, see the [Server Technology PDU Mounting Bracket Catalog](#):

[https://cdn10.servertech.com/assets/documents/documents/246/original/Mounting\\_Bracket\\_Catalog.2015-09-25.pdf?1453767377#\\_ga=1.196494891.640622464.1488848222](https://cdn10.servertech.com/assets/documents/documents/246/original/Mounting_Bracket_Catalog.2015-09-25.pdf?1453767377#_ga=1.196494891.640622464.1488848222)



## Attaching the Link Unit

Connect the PRO2 link unit with the provided 6P6C crossover cable at the link port on the PRO2 unit. The overall length of the crossover cable should not exceed 25 feet.

## Connecting to the Power Source

On PRO2 units with a rating  $\geq 24$  A, the input power cord is attached to the base of the unit. On PRO2 units with a total maximum output  $< 24$  A, you may need to attach the power cord to the unit before connecting the unit to the power source.

### ***To attach a power cord to the unit:***

1. Plug the female end of the power cord firmly into its connector on the PRO2.
2. If using the Retention Bracket Assembly (Part No. KIT-0016), use a screwdriver to tighten the two screws on the retention bracket.

### ***To connect to the power source:***

1. Plug the male end of the power cord into the AC power source.

## Connecting Devices

To avoid the possibility of noise due to arcing:

1. Keep the on/off switch on the device in the off position until after it is plugged into the outlet.
2. Connect the devices to the PRO2 outlets.



**Note:** Server Technology recommends even distribution of attached devices across all available outlets to avoid exceeding the outlet, branch, or phase limitations.

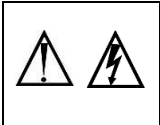

**Always disconnect ALL power supply cords before opening to avoid electrical shock.  
Afin d'éviter les chocs électriques, débranchez TOUTES les câbles électrique avant d'ouvrir  
Vor dem Öffnen immer Netzleitung abziehen um elektrischen Schlag zu vermeiden.**

## Connecting the Sensors

The PRO2 is equipped with two mini RJ11 temperature/humidity ports for attachment of the temperature/humidity sensors. Attach the mini RJ11 plug of the sensor(s) to the appropriate temperature/humidity port.

## Connecting to the Unit

Connection can be made with a serial (RS232) port or with an Ethernet port, as described:

### ***For the Serial (RS232) Port:***

The PRO2 is equipped with an RJ45 serial RS-232 port – for attachment to a PC or networked terminal server – using the supplied RJ45-to-RJ45 crossover cable and the RJ45-to-DB9F serial port adapter, as required.

### ***For the Ethernet Port:***

The PRO2 is equipped with an RJ45 10/100Base-T Ethernet port for attachment to an existing network. This connection allows access to the PRO2 unit via Telnet or Web.

## **Network Defaults**

The PRO2 is configured with the following network defaults to allow unit configuration out-of-the-box through either Telnet or Web. However, note that when the PRO2 is installed on a DHCP-enabled network, the following network defaults **do not apply** because the PRO2 ships with DHCP support enabled by default.

Network Defaults (for **non**-DHCP-enabled networks):

- IP Address: 192.168.1.254
- Subnet Mask: 255.255.255.0
- Gateway: 192.168.1.1

## **Reconfigure the Network Connection**

A local PC network connection must be reconfigured as follows. For detailed instructions about this connection, contact your system administrator. Note that a restart of the system may be required for the network reconfiguration to take effect.

- IP Address: 192.168.1.x (where “x” is 2-253)
- Subnet Mask: 255.255.255.0

## Chapter 3: Getting Started with the Firmware

This chapter introduces several key features of the firmware (version 8.0x or later) for the PRO2.



**Note:** Firmware, version 8.0, for the PRO2 product is not compatible with other Server Technology Rack Power Distribution Unit products. There is no upgrade path from earlier PDI products to PRO2 products.

### On-Board File System

The firmware Web Interface provides an embedded file system to give quick access to system configuration files, as well as the on-board and downloadable Sentry4-MIB and OID Tree for the PRO2, eliminating website MIB/OID downloads.

The page also allows GUI-based file uploads (without FTP) for system, configuration, and firmware versions. However, all PRO2 configuration/system files, MIB, and OID Tree can also be accessed via FTP/SFTP.

### Intuitive and Consistent Terminology

The design of the firmware includes intuitive and soft-mapped naming conventions between the interfaces (Web and CLI) and the PRO2 product. For example, the firmware GUI areas (cords, lines, phases, over-current protectors, branches, outlets, sensors, etc.) match the same areas designed in the PRO2 hardware architecture.

Outlet numbers are named 1-n sequentially and the outlet name is not tied to infeeds or branches. Input cords are also simply named 1-n sequentially (like 1-24), no longer 1-n for each phase (like XY 1-8, YZ 1-8, ZX 1-8).

Also, firmware naming formats match the exact silkscreened names on the hardware unit.

### Outlet Grouping

An outlet group is named group with a collection of PRO2 outlets assigned to the group. Outlet groups can be granted access to selected outlets by the administrative user (via the Web interface or CLI), and outlet activity by group can be monitored on a separate Web interface page for outlet group monitoring.

### Setting Thresholds

When setting threshold values, the PRO2 firmware allows expanded alerting capabilities. Threshold values can be set by the administrative-user for multiple low/high warning/alarm levels (and threshold hysteresis), as listed below in the following PRO2 areas.

Every item shown in the following list – for which a threshold can be set – also has a corresponding Monitoring page for viewing the item's current threshold values and operational status.

- Branch current (low and high).
- Cord power (low and high), cord apparent power (low and high), cord power factor (low), 3-phase out-of-balance (high).
- Line current (low and high).
- Outlet current (low and high), outlet power (low and high), outlet power factor (low).
- Phase voltage (low and high), phase power factor (low).
- Temperature sensor (low and high).
- Humidity sensor (low and high).
- Analog-to-Digital (ADC) sensor (low and high) – if an EMCU is connected to the PRO2 unit.

## PRO2 Dashboard View

The firmware **Overview > System** page provides a fast and high-level view of the overall condition of the PRO2 unit. The sub-system status view shows the current operational state of individual PRO2 (units, cords, lines, etc.).

The color-coded status icon for each area is hot-linked to the corresponding monitoring page to show the operating details behind the status, for example:

ID	Line Name	Current Capacity	State	Status
AA1	AA:L1	32A	On	Normal
AA2	AA:L2	32A	On	Normal
AA3	AA:L3	32A	On	Normal
AA4	AA:N	32A	On	Normal
BA1	BA:L1	32A	On	Normal
BA2	BA:L2	32A	On	Normal
BA3	BA:L3	32A	On	Normal
BA4	BA:N	32A	off	Normal

ID	Line Name	Current (A)	Utilized	Status
AA1	AA:L1	0.00A	0.0%	Normal
AA2	AA:L2	0.00A	0.0%	Normal
AA3	AA:L3	0.00A	0.0%	Normal
AA4	AA:N	0.00A	0.0%	Normal
BA1	BA:L1	2.18A	6.8%	Normal
BA2	BA:L2	0.28A	0.8%	Normal
BA3	BA:L3	1.93A	6.0%	Normal

## The User Interfaces

The Switched PRO2 offers two built-in user interfaces:

- Web interface (GUI) accessed via HTTP-enabled Ethernet connections.
- Command Line Interface (CLI) for serial and Telnet connections.

Both interfaces allow power monitoring of PIPS/POPS data points, temperature/humidity measurements, system/network configuration, outlet control, ST Eye Bluetooth® connection, user account management, and numerous other operations for the Switched PRO2.

Either interface can be used as preferred; most firmware operations can be performed on GUI screens or by CLI commands on the command line. When using either interface, the availability of firmware functions for your user login account depends on your current user access rights as granted by the system administrator.

## Username and Passwords

The Switched PRO2 is shipped with one default administrative user account (username/password is admn/admn). There is no “i” in the admn username or password.

Only an administrative user can manage user accounts, such as creating new user accounts, removing user accounts, and changing user passwords.

The PRO2 supports a maximum of 112 defined user accounts with the following restrictions:

User Account	Length	Case-Sensitive	Spaces Allowed
Usernames	1-32 characters	No	No
Passwords	1-32 characters	Yes	Yes



**Note:** For security, Server Technology recommends first creating a new user account with administrative rights, and then removing the default admn account.

## User Access Rights

The following table defines the user rights granted by the administrative user for access to PRO2 operations using either the Web GUI or the Command Line interface (CLI). Only the options for which the user has access rights will be available in the firmware for the user.

User Access Level (highest to lowest)	Description
Administrator	Administrative user; full access for all configuration, user management, all outlet power control actions (On, Off, Reboot), status, and serial/pass-thru ports.
Power User	Full access for all outlet power control actions (On, Off, Reboot), status, and serial/pass-thru ports. <b>Note: The Power User does not have access to user management.</b>
User	Partial access for outlet power control actions (On, Off, Reboot), status, and pass-thru of assigned outlets, outlet groups, and serial/pass-thru ports.
Reboot-Only User	Partial access for outlet power control actions (Reboot), status, and pass-thru of assigned outlets, outlet groups, and serial/pass-thru ports.
On-Only User	Partial access for outlet power control actions (On), status, and pass-thru of assigned outlets, outlet groups, and serial/pass-thru ports.
View-Only User	Partial access for status and pass-thru of assigned outlets, outlet groups, and serial/pass-thru ports.

The administrative user can also grant administrative-level rights to other user accounts, allowing the PRO2 unit to have more than one administrative user.

Administrative access rights cannot be removed from the default **adm** user account until an administrative user grants administrative access rights to another user account.

To use administrative commands, the user must be granted administrative user access rights.

## IPv4/IPv6 Support



**Note:** Throughout the Web and CLI firmware interfaces, both IPv4 and IPv6 formats are accepted wherever a hostname or IP address is provided.

Server Technology uses IPv6 “dual stack” support in the firmware PRO2 product line. IPv6 has been designed to succeed IPv4 as the dominant communications protocol for internet traffic, to avoid depletions of the IPv4 address space, and to allow more IP address growth. Many devices already in use support IPv6.

IPv6 has several new operational methods:

- Static IPv6 Address: The IPv6 equivalent of Static IPv4.
- DHCPv6 Address: The IPv6 equivalent of a DHCP IPv4 address, also known as a “stateful” auto-configuration of DHCPv6.
- IPv6 Stateless Auto-Configured Address – (RFC 4862): An automatically-generated unique link-local IPv6 address used for client based configurations. This address is always present in the Server Technology dual stack and cannot be disabled.
- DHCPv6 Stateless Auto-Configured Address – (RFC 3736): A “stateless” Dynamic Host Configuration Protocol (DHCP) service for IPv6 (DHCPv6). This address is used by nodes to obtain configuration information, such as addresses of DNS recursive name servers that do not require the maintenance of any dynamic state for individual clients.

### ***Protocol Support for PRO2 Firmware***

#### **IPv6 and IPv4 Protocols:**

The PRO2 firmware supports the following network IPv6 **and** IPv4 protocols:

- DNS Ping
- FTP (or SFTP) Server SNMPv1/2/3
- FTP (or SFTP) Updates SNTTP
- HTTP or HTTPS
- SMTP
- Static IPv6 DHCPv6 (stateless and stateful)
- Syslog SNMPv1/2/3 Traps
- Telnet SSH

#### **IPv4-Only Protocols:**

The PRO2 firmware supports the following network IPv4-only protocols:

- Cisco EnergyWise
- LDAP
- Load Shedding \*
- RADIUS \*
- TACACS+

\* = may work with IPv6 addresses, but not tested.

## Network-Enabled Modes



### Notes:

- For all network-enabled modes described below, the PRO2 will set an auto-configured IPv6 address, and if IPv6 router announcements are active, a stateless DHCP IPv6 address will also be set. Further, in all network-enabled modes, at least one IPv4 or one IPv6 address will be active.
- For maximum backward compatibility, the default network mode is “IPv4 only”.

Descriptions for the network-enabled modes:

- Network disabled – No IPv4 or IPv6 addresses available.
- IPv4 only, DHCP disabled (static IPv4) – If the IPv4 Static Address and Net Mask of the PRO2 are valid, they will be set.
- IPv4 only, DHCP enabled (DHCP IPv4) – The PRO2 will try to resolve an IPv4 DHCP address. If a DHCP address cannot be obtained after 90 seconds, the PRO2 can: (1) optionally fall back to its static IPv4 settings, or (2) indefinitely wait to acquire an address based on DHCP configuration settings. **This setting is the default.**
- Dual IPv6/IPv4, DHCP disabled (static IPv6/IPv4) – If the IPv6 Static Address and prefix of the PRO2 are valid, they will be set. Otherwise, the PRO2 will attempt to use DHCPv6 to obtain an IPv6 address. In addition, if the IPv4 Static Address and Net Mask of the PRO2 are valid, they will be set.
- Dual IPv6/IPv4, DHCP enabled (DHCP IPv6/IPv4) – The PRO2 will try to resolve both its IPv6 and IPv4 addresses by DHCP. If both DHCP requests are answered, the **primary** DNS server of the PRO2 will become the **primary** IPv6 DNS server, and the **secondary** DNS server of the PRO2 will become the **primary** IPv4 DNS server. If only one of the DHCP requests is answered, the DNS servers of the PRO2 will map to the **primary** and **secondary** DNS server from that request. If a DHCP address cannot be obtained after 90 seconds, the PRO2 can: (1) optionally fall back to its static IPv4 and/or IPv6 settings, or (2) indefinitely wait to acquire an address based on DHCP configuration settings.



## Viewing Network Status

You can obtain the IPv6 network status through the firmware Web Interface or Command Line Interface (CLI). For the CLI, use the **show network** command as follows:

```
Switched CDU: show network
```

```
Network Configuration
State:          Static IPv4      Network:        Dual IPv6/IPv4
Link:           Up                Negotiation:    Auto
Speed:          100 Mbps          Duplex:         Full
MAC:            00-0A-9C-60-0029
AutoCfg IPv6:  FE80::20A:9CFF:FE60:29/64
IPv4 Address:   10.1.2.65           Subnet Mask:    255.255.0.0
IPv4 Gateway:   10.1.1.1
DNS1:           10.1.5.133
DNS2:           10.1.5.134

Static IPv4/IPv6 Settings
IPv6 Address:   ::/64
IPv6 Gateway:   ::
IPv4 Address:   10.1.2.65           Subnet Mask:    255.255.0.0
IPv4 Gateway:   10.1.1.1
DNS1:           10.1.5.133
DNS2:           10.1.5.134

DHCP Settings
DHCP:           disabled
FQDN:           enabled [sentry-600029]
Boot Delay:     disabled
Static Fallback: disabled

Network Services
FTP Server:     enabled      Port: 21
FTP Updates:   disabled    Port: 21
SSH:           enabled      Port: 22      Auth: Password, Kb-Int
Telnet:        enabled      Port: 23
HTTP:          enabled      Port: 80
HTTPS:         enabled      Port: 443     Installed Cert: Self Generated
User Cert:     Disabled
Stored Files:  None
User Passphrase: (none)
SNMPv1/2:      enabled      Port: 161    TrapPort: 162
SNMPv3:        disabled    Port: 161    TrapPort: 162
SPM Access:    enabled
```



**Note:** The fields IPv4 Address, IPv4 Subnet Mask, IPv4 Gateway, DNS1, and DNS2 are equivalent to existing PRO2 IPv4 settings except that current network settings and static settings are displayed separately. This allows you to view both static configuration settings and active network settings that can be obtained using DHCP. The DNS addresses may be in IPv4 or IPv6 (based on RFC4291) format at this time.

# Chapter 4: Using the Web Interface

This chapter shows how to work with the firmware GUI (version 8.0x or later) for the PRO2.

## Logging In

Logging into the Web interface directs the Web client to the configured IP address of the Switched unit.

### To login by Web interface

In the firmware login window, provide a valid username and password, and click **OK**.

If you enter an invalid username or password, you will be prompted again.

You are given three attempts for a valid username/password combination, after which the session ends and a protected page will be displayed



**Note:** The default firmware username/password is admn/admn. There is no "i" in admn.

## Quick Tour of the GUI

The web interface provides web-based access to the firmware for the Switched unit. The interface is designed with three major screen sections shown in the following screen example:

1. System Header: Displays PRO2 description/location, IP address, and user/access level.
2. Navigation Bar: Provides access to PRO2 power monitoring, control actions, and configuration.
3. Details Window: Shows control/status information based on option selected in navigation bar.

The screenshot displays the PRO2 Sentry Switched PDU web interface. The top navigation bar includes 'Server Technology' and 'PRO2 Sentry Switched PDU'. The main content area is titled 'Overview' and contains several sections:

- System Information:** Firmware: Sentry Switched CDU Version 8.0a (Beta 10); Uptime: 0 days 2 hours 17 minutes 57 seconds; Ethernet NIC S/N: 9600010; Active Users: 1.
- Sub-system status:** A row of status indicators for Units, Cords, Lines, Phases, OCPs, Branches, Outlets, Sensors, and UPS, all showing green checkmarks.
- Line status:** A table with columns for ID, Line Name, Current, Current (A), and Status. It lists five lines (AA1, AA2, AA3, CA1, DA1) with a current of 0.00A and a status of 'Normal'. A callout box '3' highlights the 'Current' column.
- Temperature status:** A table with columns for ID, Sensor Name, Temp, Temperature (°C), and Status. It lists eight sensors (A1-E2) with temperatures ranging from 22.6°C to 23.6°C and a status of 'Normal'.
- Humidity status:** A table with columns for ID, Sensor Name, Humidity, Relative Humidity (%), and Status. It lists eight sensors (A1-E2) with humidity levels ranging from 28% to 32% and a status of 'Normal'.

The left navigation bar includes 'Overview', 'System', 'Monitoring', 'Control', 'Configuration', and 'Tools'. A callout box '2' highlights the 'Tools' menu item. The system header at the top right contains a callout box '1'.

Example of PRO2 Firmware Web Interface: Overview > System Page



**Note:** The optional blinking PRO2 location string (IP address) in the System Header may not work with all web browsers.

## Working with the Pages

### Using a configuration page:

Select an option from the navigation bar (left) and work with the option in the details window (right).

Section headers tell you the purpose of the sections.

Some pages display links in this area (or on other parts of the page) to reach more pages or to return to the previous page.

To configure PRO2 values, type values in boxes, select from drop-down menus, or check checkboxes as indicated on a page, and click the **Apply** button to save your edits. The **Cancel** button resets to the page default values before your edits and refreshes the page.

If you enter a value that is out-of-range (for example all 9's) and click **Apply**, an error message displays to show the valid range, for example, "Must be a valid integer from 200 to 240."

### Using the All or None global action:

Some pages offer global control actions with links, entry boxes, or drop-down menus that apply a single action to All items in the section (or page) or to None of the items.

## Summary of the GUI Options

### Overview

The Overview > System option is the first stop for high-level and fast monitoring of major PRO2 operational areas. The page displays a quick view of color-coded icons showing current status of the units, cords, branches, lines, phases, sensors. Click an icon for the related monitoring page to view the metrics behind the status.

The System page also shows color-coded graphs for the operational status of line current and temperature/humidity sensor readings.

General system information displays on the page to show firmware version in use, uptime data, Ethernet NIC serial number, and current number of active users.

The System page dynamically updates status and threshold values with a full-screen refresh to reflect the latest PRO2 details for instant assessment and response.

### Monitoring

The Monitoring option provides viewing of dynamically updated metrics for the PRO2 operational areas that have the highest power impact on the unit and the data center.

The design of the GUI monitoring pages follows the major areas in the hardware architecture of the PRO2, providing a separate and detailed page for the overall status of units, cords, lines, OCPs, branches, outlets, groups, and sensors.

Each system object for which a threshold can be configured – such as line current and phase voltage – has a corresponding monitor page that displays up-to-the-minute power metrics.

Many metrics are presented on the pages in color-coded graphs for at-a-glance monitoring. A regular full-page refresh dynamically updates these details to reflect the current condition of the PRO2, providing the opportunity for instant assessment and fast response to critical system issues.

### Control

The Control option allows the issuing of control actions On, Off, and Reboot for all PRO2 individual outlets, global outlets, and named outlet groups.

Outlet details are also available by individual outlet to provide the outlet's general identification, socket type, capacity, operational state, power factor, as well as color-coded graphs for current and power.

A PRO2 unit with Per Outlet Power Sensing (POPS) technology will also display values for current capacity used and reactance.

### Configuration

The Configuration option allows administrative access to all options for setting PRO2 values. The pages are organized into three major areas of configuration:

- **System** (options for PRO2 hardware areas)
- **Network** (options for setting up network protocols)
- **Access** (options for local/remote user access and management)

## Network

The Network option provides network setup options for the protocols supported by PRO2: DHCP/IP, Email/SMTP, FTP/SFTP, HTTP/HTTPS, LDAP, RADIUS, SNMP, SNTP, Syslog, TACACS+, and Telnet/SSH. The **Network** option only allows the administrator to set up network protocol parameters. To configure how the PRO2 user uses the network and system, see the **Access** option.

## Access

The Access option determines how a PRO2 user works with the network and system by configuring the options related to a user: authentication, privilege levels, user access to the unit, and additional functions for individual local users and user groups. The **Access** option only allows the administrator to determine how the PRO2 user uses the network and system. To set up network protocol parameters, use the **Network** option.

## Tools

The Tools option is a collection of several utility options for miscellaneous system actions: changing user password, pinging other network devices, viewing the system/debug log, and uploading new firmware versions. Also included are several options for rebooting the PRO2, resetting the PRO2 to factory defaults, and restarting the PRO2 with user preferences.

## Overview (Viewing the System Dashboard)

The **System** page of the Web interface is the first stop for high-level and fast monitoring of major PRO2 operational areas. The page displays a quick view of color-coded icons showing current status of the units, cords, branches, lines, phases, sensors. Click an icon for the related monitoring page to view the metrics behind the status.

The System page also shows color-coded graphs for the operational status of line current and temperature/humidity sensor readings.

General system information displays on the page to firmware version in use, uptime data, Ethernet NIC serial number, and current number of active users.

The System page dynamically updates status and threshold values with a full-screen refresh to reflect the latest PRO2 details for instant assessment and response.

The screenshot shows the PRO2 System Dashboard. The left pane contains navigation options: Overview, System, Monitoring, Control, Configuration, and Tools. The main content area displays system information (Firmware: Sentry Switched CDU Version 8.0a (Beta 10), Uptime: 2 days 0 hours 15 minutes 10 seconds, Ethernet NIC S/N: 9600041, Active Users: 2) and sub-system status (Units: ✓, Cords: ✓, Lines: ✗, Phases: ✓, OCPs: ✓, Branches: ✓, Outlets: ✓, Sensors: ✓). Below this are three tables: Line status, Temperature status, and Humidity status, each with columns for ID, Name, Value, Graph, and Status. A callout box states: "The sub-system icons across the page match the left-pane Monitoring options. Click either the icon name or select a monitoring option to display the related monitoring page."

ID	Line Name	Current	Current (A)	Status
AA1	AA:L1	0.00A	0.0	Normal
AA2	AA:L2	0.00A	0.0	Normal
AA3	AA:L3	0.00A	0.0	Normal
AA4	AA:N	0.00A	0.0	Normal
BA1	BA:L1	2.12A	0.0	Normal
BA2	BA:L2	0.25A	0.0	Normal
BA3	BA:L3	2.21A	0.0	Normal
BA4	BA:N	--	--	Read Error

ID	Sensor Name	Temp	Temperature (°C)	Status
A2	Temp_Sensor_A2	22.9°C	-8.8	Normal
B2	Temp_Sensor_B2	23.0°C	-8.8	Normal

ID	Sensor Name	Humidity	Relative Humidity (%)	Status
A2	Humid_Sensor_A2	19%	0.0	Normal
B2	Humid_Sensor_B2	20%	0.0	Normal

### How to Read the Metrics

The color-coded status icons and graphs on the System page update dynamically (normal-green, warning-yellow, critical-red) with the latest metrics of the unit, line status, and temperature/humidity sensor status.

### About Auto-Scaling

The displayed graphs reflect the internal function of *auto-scaling*. This means that if the threshold range of values changes for the graph, the graph will auto-scale to the appropriate range, allowing the graphs to still present relevant and consistent information.

### What To Look For

The dynamic performance of the System page is essential for monitoring new PRO2 installation or watching for power distribution changes in hi-density environments. High-level status information on the System page gives the chance to correct of an operating condition before it affects the entire device network.

System administrators and power users can also view the System graphs to quickly identify thermal and humidity issues that might otherwise escalate to infrastructure repairs if left unchecked.







## Overview > System Page Definitions

The System page uses the following fields and definitions:

Field	Description
ID	System-assigned internal name that cannot be changed.
Name	User-defined descriptive name for each line or temperature/humidity sensor.
Current, Temp, Humidity	Current state of the reported input load (in amps), current temperature (temperature scale °C °F, as configured), or current percent of relative humidity (%RH).
Low Limit	User-defined low limit of the load, temperature, or humidity graph. These values depend on the sensor limitation and cannot be set by the user. For example, a 0°C low limit would be displayed as 0 for a temperature sensor graph in Celsius.
High Limit	Displays the high limit of the load, temperature, or humidity graph. For the temperature/humidity sensors, these values depend on the physical sensor limits and cannot be set by the user. For example, a 100°C high limit would be displayed as 100 in the high limit in a (Celsius) temperature sensor graph.
Sensor Graph and Level Indicator	The horizontal sensor graph shows current operating conditions with color-coded icons, described in the following table, Status Icons and Descriptions". The level indicator  appears in the graph to indicate relative position of the current data value with respect to the minimum (low limit) and maximum (high limit) values displayed at the left end and right end of the graph.

## Status Icons and Descriptions

The System page uses the following icons to report current operating conditions:

Icon	Status	Description
	Reading	Unit is reading a new or restored sensor.
	Normal	Normal operation.
	Low/High Warning	Current value outside user-configured threshold range.
	Low/High Alarm	Current value outside user-configured threshold range.
	Lost	Connection has been lost to a sensor that was previously detected.
	Read Error	Error polling data from the PRO2.

## Sensor Graph Color-Coding

The sensor graph colors change dynamically to communicate operating conditions:



### For Line (Load) Status:

Green = Normal

Yellow = low warning/high warning (threshold configured by user)

Red = low alarm/high alarm (threshold configured by user)

Configure line current thresholds and threshold hysteresis at **Configuration > System > Lines**.

### For Temperature Status:

Violet = coldest; low alarm (threshold configured by user)

Blue = cold; low warning (threshold configured by user)

Green = acceptable temperature range

Yellow – warm; high warning (threshold configured by user)

Red = hot; high alarm (threshold configured by user)

Configure low/high temperature thresholds and threshold hysteresis at **Configuration > System > Sensors**.

### For Humidity Status:

Violet = wettest; high alarm (threshold configured by user)

Blue = wet; high warning (threshold configured by user)

Green = acceptable percentage of relative humidity

Yellow = dry; low warning (threshold configured by user)

Red = driest; low alarm (threshold configured by user)

Configure low/high temperature thresholds and hysteresis at **Configuration > System > Sensors**.

## System Information

This section of the Summary page provides general information:

- **Firmware:** Current firmware version
- **Uptime:** Cumulative time the PRO2 has been up and running since the last unit restarted. Shows continuous, real-time system updates with an approximate 5-second automatic refresh. A manual refresh is not required.
- **Ethernet NIC S/N:** The serial number of the PRO2 derived from the Ethernet NIC.
- **Active Users:** Number of active user sessions accessing the firmware. These sessions include serial, Telnet, SSH, and Web sessions. Also shows sessions that an unauthorized user may be attempting to access the system. The number changes instantly as the number of active user sessions changes. A total of 4 concurrent web user sessions are allowed (HTTPS or HTTPS).



**Note:** Depending on the web browser, multiple web accesses from the same machine are often considered as one active user.



## Sub-System Status

This Sub-System section of the Summary page provides a quick status view of the current operational state of major PRO2 areas (units, cords, branches, etc.) showing a color-coded status icon.

Also provided is a link from each of the sub-system areas to the related monitoring page:

Sub-system status							
<b>Units</b>	<b>Cords</b>	<b>Lines</b>	<b>Phases</b>	<b>OCPs</b>	<b>Branches</b>	<b>Outlets</b>	<b>Sensors</b>
✓	✓	✗	✓	✓	✓	✓	✓

Click the name of one of the PRO2 system areas to display its corresponding Monitoring page.

Line current									
	ID	Line Name	Current (A)			Utilized	Status		
✓	AA1	AA:L1	<b>0.00A</b>	0.0	▼	32.0	<b>0.0%</b>	<b>Normal</b>	
✓	AA2	AA:L2	<b>0.00A</b>	0.0	▼	32.0	<b>0.0%</b>	<b>Normal</b>	
✓	AA3	AA:L3	<b>0.00A</b>	0.0	▼	32.0	<b>0.0%</b>	<b>Normal</b>	
✓	AA4	AA:N	<b>0.00A</b>	0.0	▼	32.0	<b>0.0%</b>	<b>Normal</b>	
✓	BA1	BA:L1	<b>2.17A</b>	0.0	▼	32.0	<b>6.7%</b>	<b>Normal</b>	
✓	BA2	BA:L2	<b>0.00A</b>	0.0	▼	32.0	<b>0.0%</b>	<b>Normal</b>	
✓	BA3	BA:L3	<b>2.23A</b>	0.0	▼	32.0	<b>6.9%</b>	<b>Normal</b>	
✗	BA4	BA:N	--						<b>Read Error</b>

View detailed operating status on the Monitoring page.

● Read Error

## Monitoring (Analyzing Metrics)

The **Monitoring** section of the Web interface provides viewing of dynamically updated metrics for the PRO2 operational areas that have the highest power impact on the unit and the data center.

The design of the GUI monitoring pages follows the major areas in the hardware architecture of the PRO2, providing a separate and detailed page for the overall status of units, cords, lines, OCPs, branches, outlets, groups, and sensors.

Each system object for which a threshold can be configured – such as line current and phase voltage – has a corresponding monitor page that displays up-to-the-minute power metrics.

Many metrics are presented on the pages in color-coded graphs for at-a-glance monitoring. A regular full-page refresh dynamically updates these details to reflect the current condition of the PRO2, providing the opportunity for instant assessment and fast response to critical system issues.

### Monitoring > Units

The **Units** page is a high-level quick reference for the PRO2 units in the network, identifying the connected master/link units (and any connected external monitoring devices), the current LED display orientation of the PRO2 units, and the overall current operational status of all units and devices.



Unit status		ID	Unit Name	Unit Type	Display Orientation	Status
<input checked="" type="checkbox"/>	A	Master	Master	Auto (Normal)	Normal	
<input checked="" type="checkbox"/>	C	Link2	Link	Auto (Normal)	Normal	
<input checked="" type="checkbox"/>	D	Link3	Link	Auto (Normal)	Normal	
<input checked="" type="checkbox"/>	E	EMCU	EMCU	--	Normal	

#### What to look for:

The operating status of all units (master and link) should be Normal (green). The Status field reports the overall health of the units and their connectivity, not an exceeded user-defined threshold. Depending on a yellow or red status message, basic troubleshooting will be needed to determine the best solution for the affected unit.

## Monitoring > Cords

The **Cords** page displays cord hardware specifications, overall operational status of each cord, and individual color-coded graphs and status for cord active power (W), cord apparent power (VA), power factor (if present), and cord 3-phase out-of-balance level (%).



**Note:** The inlet type, frequency, power capacity, and energy rating of the cord were determined for the PRO2 product at factory assembly and cannot be user-edited.

Cord status							
ID	Cord Name	Inlet Type	Frequency	Power Capacity	Energy	State	Status
AA	Master_Cord_A	IEC-60309	60Hz	22080VA	356.1kWh	On	Normal

Cord power			
ID	Cord Name	Active Power (W)	Status
AA	Master_Cord_A	500W	Normal

Cord apparent power			
ID	Cord Name	Apparent Power (VA)	Status
AA	Master_Cord_A	502VA	Normal

Cord power factor			
ID	Cord Name	Power Factor	Status
AA	Master_Cord_A	1.00	Normal

Cord 3-phase out-of-balance level (%)			
ID	Cord Name	3-phase out-of-balance level	Status
AA	Master_Cord_A	20.0%	High Warning

### What to look for:

The cord power graphs display a blinking warning (yellow) when the total input load exceeds the user-defined threshold. If an overload occurs, a blinking error condition (red) is displayed. The unit continues to display yellow and red states until the condition changes or the issue has been resolved.

The default input feed high load threshold is 80% of the input feed maximum load capacity.

Cord power thresholds are user-defined at **Configuration > System > Cords**.

## Monitoring > Lines

The **Lines** page shows overall line operational status, line load capacity, line state, and a color-coded graphic for the current used by each line.

The screenshot shows the 'Lines' monitoring page for a PRO2 Sentry Switched PDU. The interface includes a navigation menu on the left with options like Overview, Monitoring, Units, Cords, Lines, Phases, Over-Current Protectors, Branches, Outlets, Groups, Sensors, UPS, Control, Configuration, and Tools. The main content area displays the following data:

Line status					
ID	Line Name	Current Capacity	State	Status	
✓ AA1	AA:L1	30A	On	Normal	
✓ AA2	AA:L2	30A	On	Normal	
✓ AA3	AA:L3	30A	On	Normal	
✓ CA1	CA:L	30A	On	Normal	
✓ DA1	DA:L	30A	On	Normal	

Line current					
ID	Line Name	Current (A)	Utilized	Status	
✓ AA1	AA:L1	0.00A	0.0	0.0%	Normal
✓ AA2	AA:L2	0.00A	0.0	0.0%	Normal
✓ AA3	AA:L3	0.00A	0.0	0.0%	Normal
✓ CA1	CA:L	0.00A	0.0	0.0%	Normal
✓ DA1	DA:L	0.00A	0.0	0.0%	Normal

### What to look for:

The line status and line current status should be Normal, and the line current should be operating within defined thresholds.

The line current graph displays a blinking warning (yellow) when the total input load on an infeed exceeds the user-defined threshold. If an overload occurs, a blinking error condition (red) is displayed. The unit continues to display yellow and red states until the condition changes or the issue has been resolved.

The default input feed high load threshold is 80% of the input feed maximum load capacity.

The line current thresholds are user-defined at **Configuration > System > Lines**.

## Monitoring > Phases

The **Phases** page reports the current phase status, voltage, and power factor.



### What to look for:

The phase status, voltage status, and phase power factor should be Normal, and the phase voltage and power factor should be operating within defined thresholds.

The phase voltage graph displays a blinking warning (yellow) when the total input load on an infeed exceeds the user-defined set threshold. If an overload occurs, a blinking error condition (red) is displayed.

The unit continues to display yellow and red states until the condition changes or the issue has been resolved. The same color-coding applies to the phase power factor graph if the threshold is exceeded.

The default input feed high load threshold is 80% of the input feed maximum load capacity.

Phase voltage and power factor thresholds are user-defined at **Configuration > System > Phases**.

## Monitoring > Over-Current Protectors

The **Over-Current Protectors (OCPs)** page displays the current status, type, and current capacity (A) for any OCPs connected to the PRO2 unit. If there are no OCPs on the unit, the OCP monitoring page will not be available.

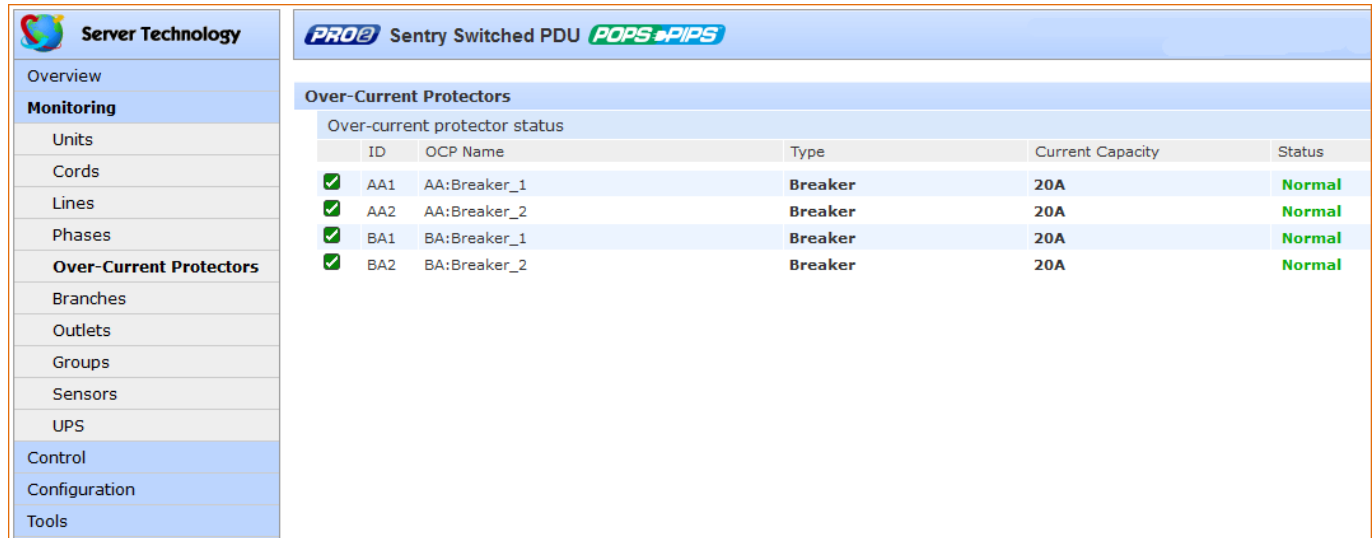

The screenshot shows the 'Server Technology' web interface for a 'PRO2 Sentry Switched PDU'. The 'Monitoring' section is active, and the 'Over-Current Protectors' page is displayed. A table titled 'Over-current protector status' lists the following data:

ID	OCP Name	Type	Current Capacity	Status
AA1	AA:Breaker_1	Breaker	20A	Normal
AA2	AA:Breaker_2	Breaker	20A	Normal
BA1	BA:Breaker_1	Breaker	20A	Normal
BA2	BA:Breaker_2	Breaker	20A	Normal

### What to look for:

The operating status of all OCPs listed should be Normal.

## Monitoring > Branches

The **Branches** page displays branch status that supports the standard Branch Current Monitoring feature of the PRO2. Branch Current Monitoring allows the configuration of thresholds on the branch circuit to provide notification before a breaker trips. Displayed on the page are branch current (A), percentage of current utilized, and threshold status.

**Note:** The PRO2 allows the capability to load-shed based on branch current status.

The screenshot shows the 'Server Technology' interface for a 'PRO2 Sentry Switched PDU'. The left sidebar contains navigation options: Overview, Monitoring (selected), Units, Cords, Lines, Phases, Over-Current Protectors, Branches, Outlets, Groups, Sensors, UPS, Control, Configuration, and Tools. The main content area is titled 'Branches' and contains two tables.

Branch status							
ID	Branch Name	OCP ID	Phase ID	Current Capacity	State	Status	
✓ AA1	AA:Branch_1	AA1	AA1	20A	On	Normal	
✓ AA2	AA:Branch_2	AA2	AA1	20A	On	Normal	
✓ BA1	BA:Branch_1	BA1	BA1	20A	On	Normal	
✓ BA2	BA:Branch_2	BA2	BA1	20A	On	Normal	

Branch current							
ID	Branch Name	Current (A)	Utilized	Status			
✓ AA1	AA:Branch_1	0.00A	0.0	20.0	0.0%	Normal	
✓ AA2	AA:Branch_2	0.00A	0.0	20.0	0.0%	Normal	
✓ BA1	BA:Branch_1	0.00A	0.0	20.0	0.0%	Normal	
✓ BA2	BA:Branch_2	0.00A	0.0	20.0	0.0%	Normal	

### What to look for:

Branch names are set internally on the PRO2 at factory assembly and cannot be changed. Branch operations status should be Normal and branch current should be within defined thresholds. Branch threshold range values are affected by changing the current capacity of an over-current protector (OCP).

The branch status and branch current status displays a blinking warning (yellow) and red (error condition) when a branch exceeds the user-defined thresholds. The branch continues to display yellow and red states until the condition changes or the issue has been resolved.

Branch current thresholds are user-defined at **Configuration > System > Branches**.

## Monitoring > Outlets

The **Outlets** page lists the outlets in the PRO2 unit with a quick overview of general outlet information, including operational status based on user-configured thresholds for current, active power, and power factor.

Also displayed are the last user action (on, off, reboot) issued on the outlet (shown in the State column), and the outlet's last reported condition (shown in the Control State column).

The page allows a fast drill-down from the ID link for more operational data about a specific outlet in the list.

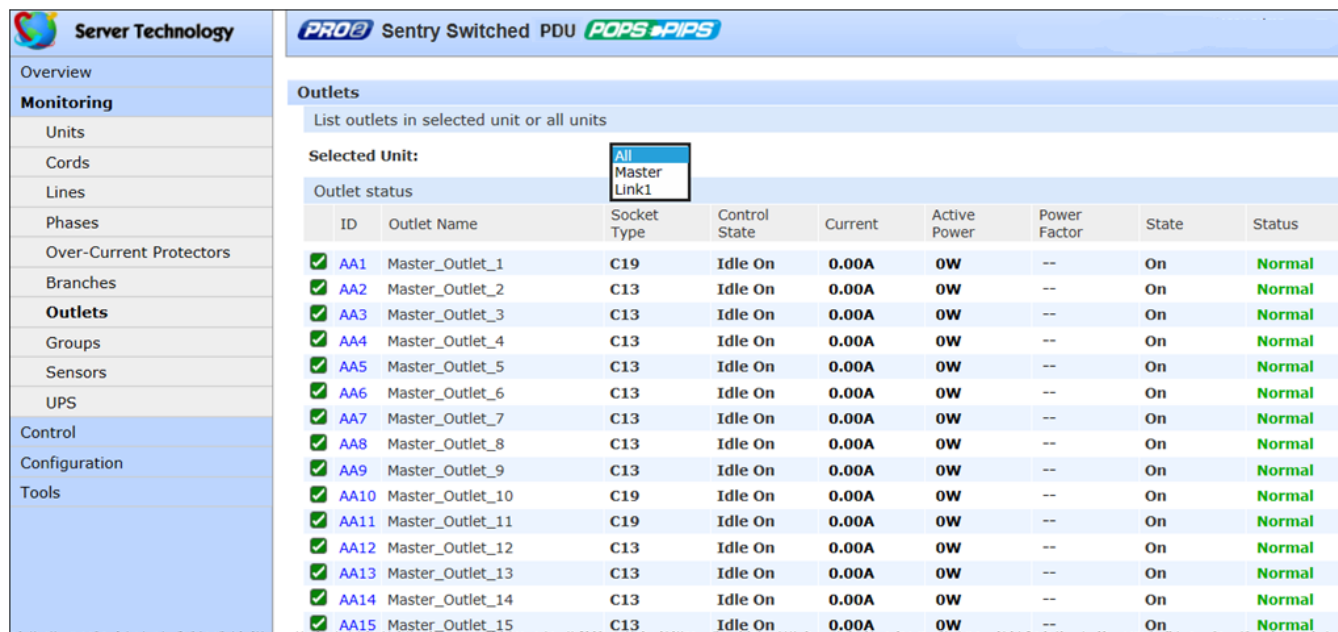

The screenshot shows the 'Server Technology' monitoring interface. The main content area is titled 'Outlets' and displays a table of outlet information. A dropdown menu for 'Selected Unit' is open, showing 'All Master Link1'. The table has columns for ID, Outlet Name, Socket Type, Control State, Current, Active Power, Power Factor, State, and Status. All outlets are currently in a 'Normal' status.

ID	Outlet Name	Socket Type	Control State	Current	Active Power	Power Factor	State	Status
AA1	Master_Outlet_1	C19	Idle On	0.00A	0W	--	On	Normal
AA2	Master_Outlet_2	C13	Idle On	0.00A	0W	--	On	Normal
AA3	Master_Outlet_3	C13	Idle On	0.00A	0W	--	On	Normal
AA4	Master_Outlet_4	C13	Idle On	0.00A	0W	--	On	Normal
AA5	Master_Outlet_5	C13	Idle On	0.00A	0W	--	On	Normal
AA6	Master_Outlet_6	C13	Idle On	0.00A	0W	--	On	Normal
AA7	Master_Outlet_7	C13	Idle On	0.00A	0W	--	On	Normal
AA8	Master_Outlet_8	C13	Idle On	0.00A	0W	--	On	Normal
AA9	Master_Outlet_9	C13	Idle On	0.00A	0W	--	On	Normal
AA10	Master_Outlet_10	C19	Idle On	0.00A	0W	--	On	Normal
AA11	Master_Outlet_11	C19	Idle On	0.00A	0W	--	On	Normal
AA12	Master_Outlet_12	C13	Idle On	0.00A	0W	--	On	Normal
AA13	Master_Outlet_13	C13	Idle On	0.00A	0W	--	On	Normal
AA14	Master_Outlet_14	C13	Idle On	0.00A	0W	--	On	Normal
AA15	Master_Outlet_15	C13	Idle On	0.00A	0W	--	On	Normal

### What to look for:

The operating status of all outlets should be Normal. If necessary, view operational details for an outlet. The ID and socket type are determined at factory assembly and cannot be user-configured.

Each outlet has a unique number, and the numbering sequence of outlets is not associated with the PRO2's branch or phase number. For example, a 30-outlet PRO2 unit (either single-phase or 3-phase) unit will have outlet numbers sequenced from 1 to 30.

The outlet status displays a blinking warning (yellow) and red (error condition) when an outlet exceeds the user-defined thresholds. The status continues to display yellow and red states until the condition changes or the issue has been resolved.

A descriptive text outlet name can be configured at **Configuration > System > Outlets**.



**To view details for an outlet:**

1. From the Control > Outlets page, click the ID link for any outlet in the list, such as AA2 in this example.

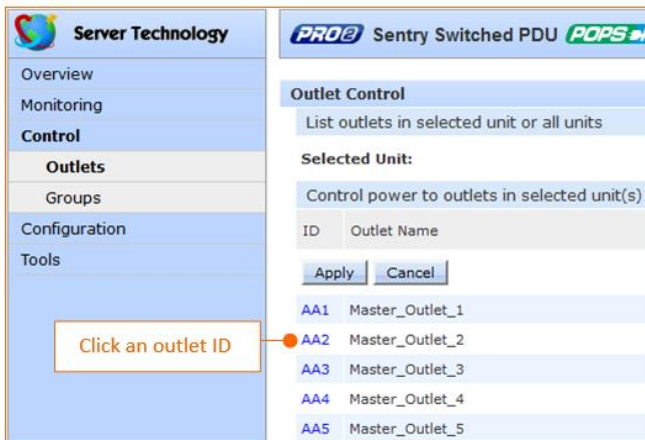

2. The AA2 Outlet Details page displays specific information about the selected outlet that includes capacity and usage, along with status graphs for outlet current (A) and outlet power (W).

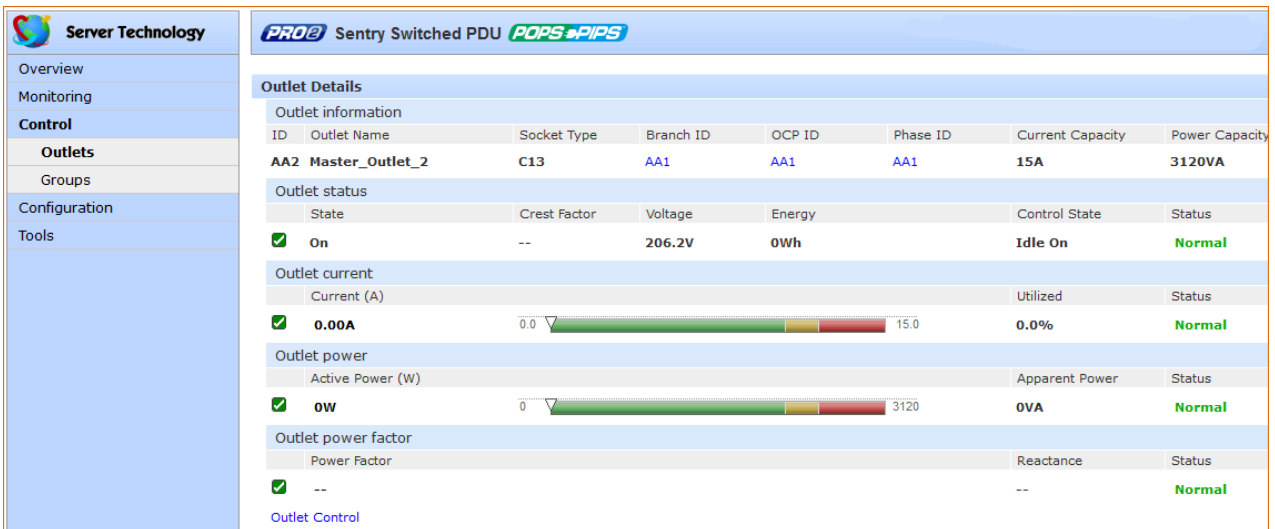

3. To return to the previous monitoring page, click the Outlet Monitor link.

## Monitoring > Groups

The **Groups** page shows the status of all outlets in a user-defined outlet group. An outlet group is named group with a collection of PRO2 outlets assigned to the group.

The page also allows a fast drill-down by outlet ID for more details about the outlet.

**Server Technology** | **PRO2 Sentry Switched PDU** | **POPS PIPS**

**Groups**

List outlets in selected group

Selected Group:  Select an outlet group from the drop-down list.

Status of all outlets in selected group

ID	Outlet Name	Socket Type	Control State	Current	Power	Power Factor	State	Status
AA1	Master_Outlet_1	C19	Idle On	0.00A	0W	--	On	Normal
AA2	Master_Outlet_2	C13	Idle On	0.00A	0W	--	On	Normal
AA3	Master_Outlet_3	C13	Idle On	0.00A	0W	--	On	Normal
AA4	Master_Outlet_4	C13	Idle On	0.00A	0W	--	On	Normal
AA5	Master_Outlet_5	C13	Idle On	0.00A	0W	--	On	Normal
AA6	Master_Outlet_6	C13	Locked On	0.00A	0W	--	On	Normal
AA7	Master_Outlet_7	C13	Locked On	0.00A	0W	--	On	Normal
AA8	Master_Outlet_8	C13	Idle On	0.00A	0W	--	On	Normal
AA9	Master_Outlet_9	C13	Idle On	0.00A	0W	--	On	Normal
AA10	Master_Outlet_10	C19	Idle On	0.00A	0W	--	On	Normal
AA11	Master_Outlet_11	C13	Idle On	0.00A	0W	--	On	Normal
AA12	Master_Outlet_12	C13	Idle On	0.00A	0W	--	On	Normal
AA13	Master_Outlet_13	C13	Idle On	0.00A	0W	--	On	Normal
AA14	Master_Outlet_14	C13	Idle On	0.00A	0W	--	On	Normal
AA15	Master_Outlet_15	C13	Idle On	0.00A	0W	--	On	Normal

The outlets in this list were administrator-assigned to "Outlet\_Group\_1".

### What to look for:

The operating status of all outlets within a selected group should be Normal. If necessary, view operational details for an outlet.

The outlet status for a group displays a blinking warning (yellow) and red (error condition) when an outlet exceeds the user-defined thresholds. The status continues to display yellow and red states until the condition changes or the issue has been resolved.

Creating an outlet group and assigning outlet access to the group is done at **System > Configuration > Groups**.

### To view operational details for an outlet in an outlet group:

1. From the Groups page, select an outlet group from the drop down list.

**Server Technology** | **PRO2 Sentry Switched PDU** | **POPS PIPS**

**Groups**

List outlets in selected group

Selected Group:  Select an outlet group.

Status of all outlets in selected group

ID	Outlet Name	Type	State
AA1	Master_Outlet_1	C19	Idle On
AA2	Master_Outlet_2	C13	Idle On
AA3	Master_Outlet_3	C13	Idle On
AA4	Master_Outlet_4	C13	Idle On
AA5	Master_Outlet_5	C13	Idle On
AA6	Master_Outlet_6	C13	Locked On
AA7	Master_Outlet_7	C13	Locked On
AA8	Master_Outlet_8	C13	Idle On
AA9	Master_Outlet_9	C13	Idle On
AA10	Master_Outlet_10	C19	Idle On

Click an outlet ID.

- When you click an outlet ID link in the list, the details page for that outlet displays:

The screenshot displays the 'Sentry Switched PDU' monitoring interface. On the left is a navigation menu with categories like 'Monitoring' and 'Control'. The main content area shows 'Outlet Details' for 'AA9 Master\_Outlet\_9'. It includes a table for 'Outlet information', a table for 'Outlet status', and three status graphs: 'Outlet current', 'Outlet power', and 'Outlet power factor'. Each graph shows a green bar representing current usage and a red bar representing capacity, with a 'Normal' status indicator.

Outlet information							
ID	Outlet Name	Socket Type	Branch ID	OCP ID	Phase ID	Current Capacity	Power Capacity
AA9	Master_Outlet_9	C13	AA1	AA1	AA1	15A	3120VA

Outlet status						
State	Crest Factor	Voltage	Energy	Control State	Status	
On	--	206.8V	0Wh	Idle On	Normal	

Outlet current			
Current (A)	Utilized	Status	
0.00A	0.0%	Normal	

Outlet power			
Active Power (W)	Apparent Power	Status	
0W	0VA	Normal	

Outlet power factor		
Power Factor	Reactance	Status
--	--	Normal

[Group Monitor](#)

- The AA14 Outlet Details page displays specific information about the selected outlet that includes capacity and usage, along with status graphs for outlet current (A) and outlet power (W).
- To return to the previous monitoring page, click the Group Monitor link.

## Monitoring > Sensors

The **Sensors** page provides a quick view of the operating status and color-coded graphic showing current operating value of environmental sensors for temperature and humidity.

Temperature sensor status				
ID	Sensor Name	Temperature (°C)		Status
✓ A1	Temp_Sensor_A1	24.9°C	-8.8	59.8

Humidity sensor status				
ID	Sensor Name	Relative Humidity (% RH)		Status
✓ A1	Humid_Sensor_A1	24% RH	0.0	100.0

### What to look for:

The operating status of all sensors should be Normal, and operating temperature or relative humidity should be within defined thresholds.

### Temperature Status

The Temperature graph displays a blinking warning or critical error whenever temperature exceeds low or high threshold. The PRO2 continues to display the status until the condition changes or the issue has been resolved.

#### Temperature graph colors:

- Violet = coldest; low alarm (threshold configured by user)
- Blue = cold; low warning (threshold configured by user)
- Green = acceptable temperature range
- Yellow – warm; high warning (threshold configured by user)
- Red = hot; high alarm (threshold configured by user)

The default range of low/high temperature threshold values is -40 to 123(C°). Temperature threshold values are user-defined at **Configuration > System > Sensors**.

### Humidity Status

The Humidity graph displays a blinking warning or critical error whenever humidity exceeds low or high threshold. The PRO2 continues to display the status until the condition changes or the issue has been resolved.

#### Humidity graph colors:

- Violet = wettest; high alarm (threshold configured by user)
- Blue = wet; high warning (threshold configured by user)
- Green = acceptable percentage of relative humidity
- Yellow = dry; low warning (threshold configured by user)
- Red = driest; low alarm (threshold configured by user)

The default range of low/high relative humidity threshold values is 0-100%RH. Humidity threshold values are user-defined at **Configuration > System > Sensors**.

### Temperature/Humidity Sensor Status

Status	Description
Found	The PRO2 found the sensor and connection is established.
Not Found	On a fresh reboot, the PRO2 does not find a sensor.
Lost	The connection to a previously found sensor is now lost.
No Comm	Communication loss occurred due to a hardware issue (not loss of communication with the probes). <sup>1</sup>

<sup>1</sup> The ENV part of the sensor supports two temperature/humidity (T/H) probes as part of the master unit, two T/H probes as part of the link unit, and the optional EMCU-1-18 (which can support two T/H probes, four contact-closure monitoring points, and one water sensor). The “No Comm” sensor status is not loss of communication with the probes themselves.

## Environmental Monitor (EMCU) Status

If an EMCU is connected to the PRO2, the Sensors pages will also include monitoring of water, contact closures, and analog-to-digital (ADC) sensors.

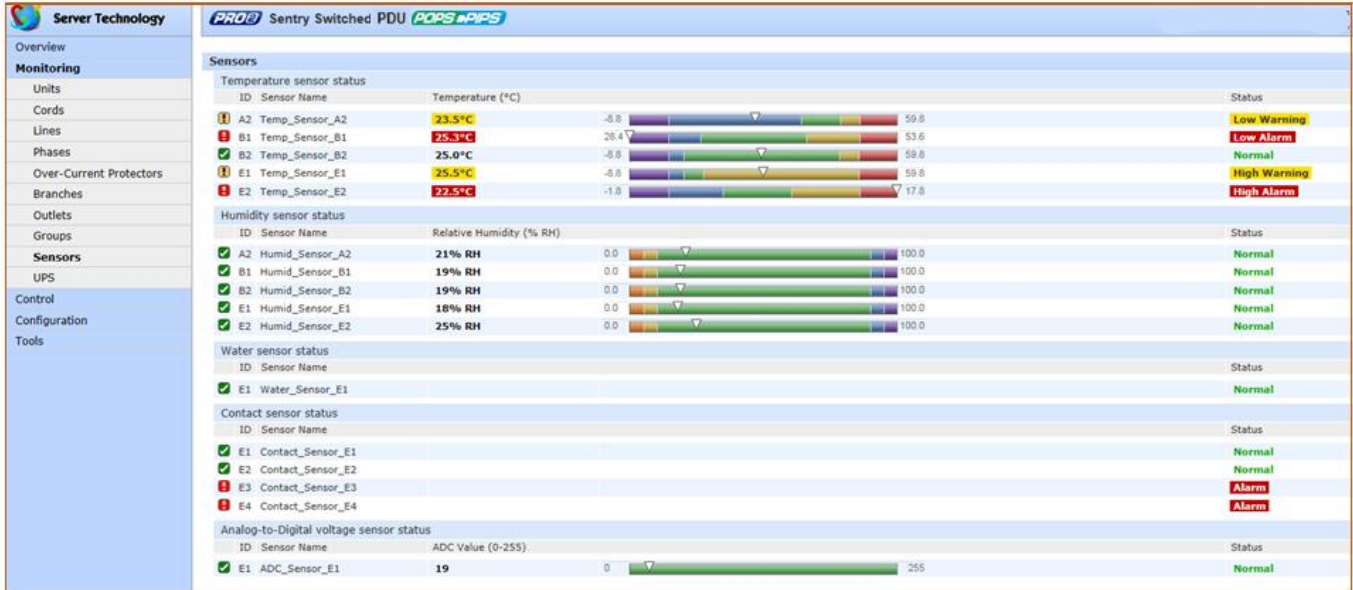

### What to look for:

The operating status of all sensors should be Normal and operating within defined thresholds. View the color-coded graph showing current operating range within thresholds for the ADC.

Water and contact closure sensors can have either Normal or Alarm status – there are no other states or value ranges.

The ADC sensors can be configured at **Configuration > System > Sensors**

## Monitoring > UPS

The **UPS** page identifies each UPS device connected to the PRO2 unit, displaying hostname/IP address and UPS status.

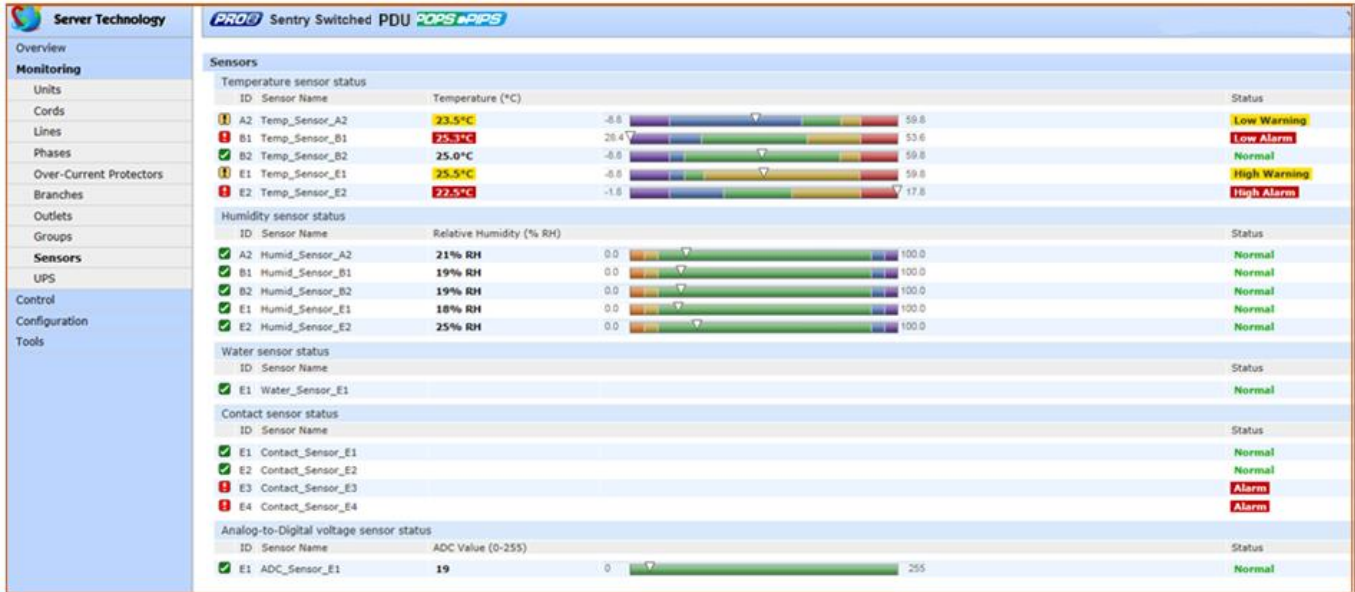

### What to look for:

Monitoring page will be blank if a UPS has not been connected to, and configured for, the PRO2. After connecting a UPS to the unit, configure the UPS and the lines to be powered by the UPS at **Configuration > System > UPS**.

## Control (Managing Outlets)

The **Control** section of the Web interface allows the issuing of outlet control actions On, Off, and Reboot for individual outlets in a master unit (or in all units), for all outlets globally in a master unit (or in all units), and for named outlet groups.

Outlet details are also available by individual outlet to provide the outlet's general identification, socket type, capacity, operational state, power factor, as well as color-coded graphs for current and power.

A PRO2 unit with Per Outlet Power Sensing (POPS) technology will also display values for current capacity used and reactance.

### Control > Outlets

The **Outlet Control** page displays outlets assigned to the current user:

Note the three outlet control drop-down menus:

**Step 1.** Choose outlet control for all units or for the master unit only.

**Step 2.** Based on the unit selected in Step 1, (a) select the outlet control command All On, All Off, or All Reboot to issue on all outlets on the page, or (b) select the outlet control command On, Off, Reboot to issue on a specific outlet on the page.

ID	Outlet Name	Control Action	Wake On	0.00A	0W	--	On	Normal
AA1	Master_Outlet_1	None	Wake On	0.00A	0W	--	On	Normal
AA2	Master_Outlet_2	None	Wake On	0.00A	0W	--	On	Normal
AA3	Master_Outlet_3	None	Wake On	0.00A	0W	--	On	Normal
AA4	Master_Outlet_4	None	Wake On	0.00A	0W	--	On	Normal
AA5	Master_Outlet_5	None	Wake On	0.00A	0W	--	On	Normal
AA6	Master_Outlet_6	None	Wake On	0.00A	0W	--	On	Normal
AA7	Master_Outlet_7	None	Wake On	0.00A	0W	--	On	Normal
AA8	Master_Outlet_8	None	Wake On	0.00A	0W	--	On	Normal

#### What to look for:

- Provides viewing of outlet current, power, power factor, current control state applied to the PRO2, and status information.
- Includes an ID link for viewing detailed operational data about the outlet.
- Allows the issuing of outlet power control actions (On, Off, Reboot) on individual outlets or on all outlets globally, in a master unit or in all units.

#### To issue outlet control actions (globally on all outlets or on individual outlets):

1. From the Selected Unit drop-down menu, choose All or Master. The page refreshes to show the outlets available for the selected unit.
2. To issue outlet control **globally** on all displayed outlets, from the Control Action drop-down menu, select All On, All Off, or All Reboot. To issue outlet control on one or more **individual** outlets, from the Control action drop-down menu for the individual outlet(s), select On, Off, or Reboot.
3. Click **Apply**. The command action is issued immediately on the specified outlet(s).



**To view detailed operational details for an outlet:**

1. From the Outlet Control page, click the Outlet ID link for any outlet in the list, such as AA2 in this example.

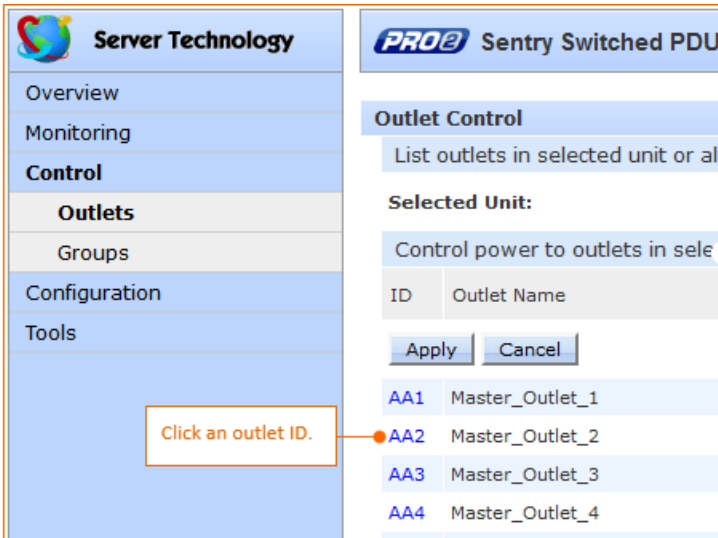

2. The Outlet Details page displays for outlet AA2 showing power, capacity, and other operational information:

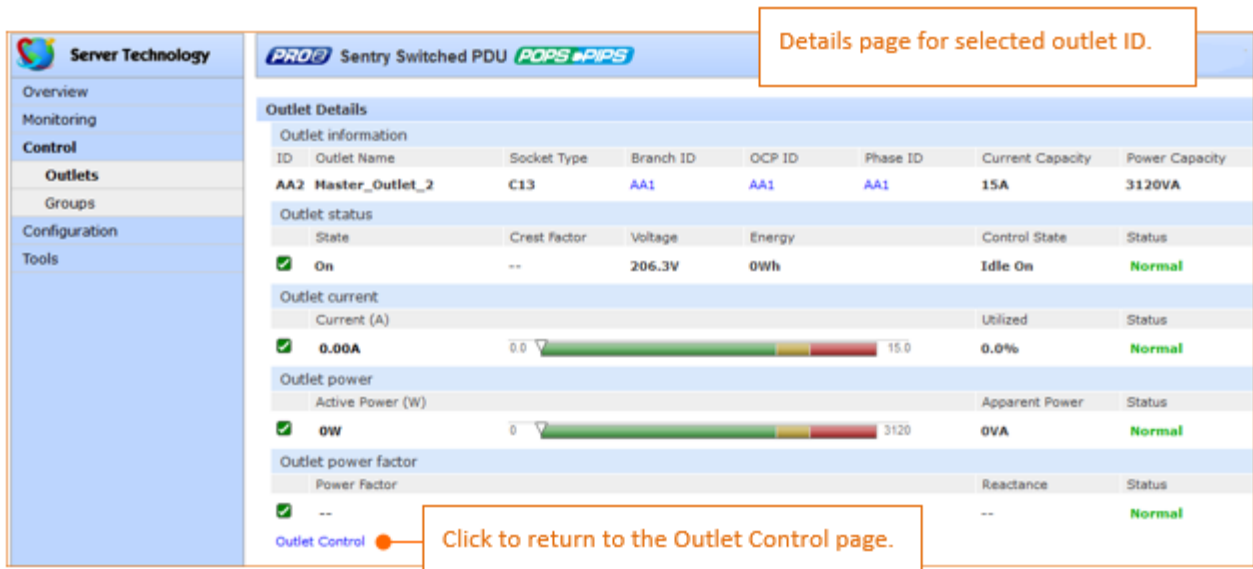

## Control > Groups

The **Control Groups** page displays outlet groups assigned to a current user and allows power control actions (On, Off, Reboot) to be applied to all outlets in a selected outlet group.



**Note:** An outlet group is a named collection of outlets in a PRO2 (up to four enclosures) with a single IP address.

ID	Outlet Name	State	Current	Power	Factor	State	Status
AA4	Master_Outlet_4	Idle On	0.00A	0W	--	On	Normal
AA6	Master_Outlet_6	Locked On	0.00A	0W	--	On	Normal
AA7	Master_Outlet_7	Locked On	0.00A	0W	--	On	Normal
AA16	Master_Outlet_16	Idle On	0.00A	0W	--	On	Normal
BA13	Link1_Outlet_13	Idle On	0.00A	0W	--	On	Normal

### To issue outlet control on a specific outlet group:

1. From the group drop-down menu, select the outlet group by name.
2. From the control action drop-down menu, select the outlet command On, Off, or Reboot.
3. Click **Apply**. The command is issued immediately on all outlets in the selected outlet group.

## Outlet State/Control State Descriptions

The following table shows the differences between outlet state and control state

- The **outlet state** is the current operating state of the outlet.
- The **control state** is the last user-issued control action on the outlet.

Outlet State	Control State	Description
On	On	Outlet is on.
Off	Off	Outlet is off.
Off	Pend On	Outlet is off and about to turn on in response to a sequence timer.
Off	Reboot	Outlet is off and a Reboot action has been initiated.
On	Idle On	A restart has occurred – last control state has been maintained.
On	Idle Off	A restart has occurred – last control state has been maintained.
On	Wake On	A power-loss has occurred – wakeup state has been applied.
Off	Wake Off	A power-loss has occurred – wakeup state has been applied.
On/Wait	Off	Outlet state in transition – re-query of outlet status required.
Off/Wait	On	Outlet state in transition – re-query of outlet status required.
On/Error	(varies)	Error state – outlet should be off but current is sensed at the outlet.
Off/Error	(varies)	Error state – outlet should be on but no current is sensed at the outlet.
Off/Fuse	On	Outlet should be on but a blown fuse has been detected.
On/Fuse	On	Outlet should be on but a blown fuse has been detected downstream
No Comm	(varies)	Communication to the outlet has been lost – control state will be applied when communication is re-established.

## Configuration (Setting Values)

The **Configuration** section allows administrative access to all options for setting PRO2 values. The pages are organized into three major areas of configuration:

- **System** (options for PRO2 hardware areas)
- **Network** (options for setting up network protocols)
- **Access** (options for local/remote user access and management)

### System > About

The **About** page allows: (1) reference for system-wide configuration data, (2) configuration of the system location, and (3) the option for a blinking system location on PRO2 GUI monitoring pages.

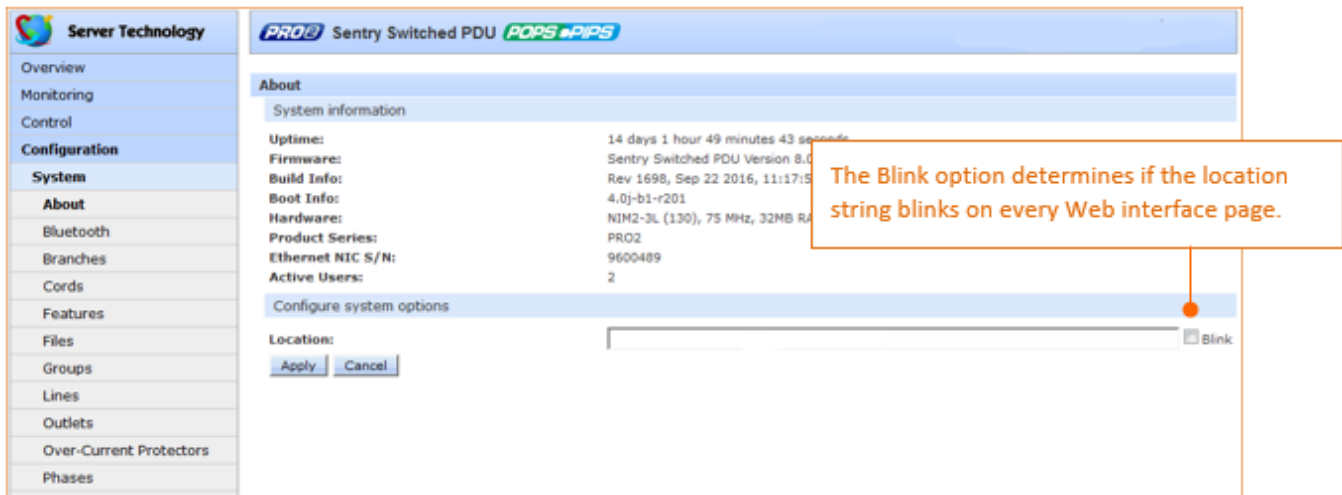

The screenshot shows the 'About' page in the PRO2 Sentry Switched PDU configuration interface. The page is divided into two main sections: 'System information' and 'Configure system options'. The 'System information' section lists various system details, and the 'Configure system options' section includes a 'Location' text box and a 'Blink' checkbox. A callout box points to the 'Blink' checkbox with the text: 'The Blink option determines if the location string blinks on every Web interface page.'

### Viewing system reference information:

- **Uptime:** Cumulative time the PRO2 has been up and running since the last unit restarted. Shows continuous, real-time system updates with an approximate 5-second automatic refresh. A manual refresh is not required.
- **Firmware:** Current firmware version.
- **Build Info:** Displays revision number and date/time of most recent firmware version build.
- **Boot Info:** Identification number from the system boot loader.
- **Hardware:** Displays information about the PCB used in the PRO2 unit.
- **Ethernet NIC S/N:** The serial number of the PRO2 derived from the Ethernet NIC.
- **Active Users:** Number of users currently logged in.

### To set the blink option:

1. Type a descriptive PRO2 location name that appears in the system eader section of every Web interface page (upper right corner).
2. (Optional) Check the Blink checkbox to enable blinking of the PRO2 location string (IP address) on the Web interface pages. Even if Blink is enabled, the blinking may not work with all web browsers.
3. Click **Apply**.

## System > Bluetooth

The **Bluetooth** page allows configuration of the parameters needed for the Bluetooth™ mobile monitoring solution.

The screenshot shows the configuration interface for the Bluetooth module. On the left is a navigation menu with options like Overview, Monitoring, Control, Configuration, System, About, Bluetooth, Branches, Cords, Features, Files, Groups, Lines, Outlets, Over-Current Protectors, and Phases. The main area is titled 'Bluetooth' and contains the following settings:

- Bluetooth:**  Enable
- Name:** ST Eye
- Pin Code:** 9611
- Discoverability:** Limited
- Transmission Power:** 0 dbm

Buttons for 'Apply' and 'Cancel' are located at the bottom left of the configuration area.

### To configure Bluetooth™ options

1. To enable Bluetooth mobile monitoring, check Enable.
2. Provide a value for the Bluetooth parameters: name, pin code, discoverability, and transmission power, as described in the following table.
3. Click **Apply**.

### Bluetooth™ Firmware Parameters

Parameter	Description and Values/Range
Bluetooth Name	Descriptive name of the Bluetooth module that displays in the list of discovered modules on the Android mobile device or Apple iPad/iPhone. The default module name is "ST Eye". Valid length of name is 1-31 characters; the name cannot be blank.
Bluetooth Discoverability	Settings that determine the current status of the pushbutton on the Bluetooth module: <ul style="list-style-type: none"><li>• Enabled: The Bluetooth module is discoverable, even without pressing the pushbutton.</li><li>• Limited: (Default) The pushbutton on the Bluetooth module must be pressed to make the module discoverable for 60-seconds.</li><li>• Disabled: The Bluetooth module is never in discoverable mode.</li></ul>
Bluetooth Pin Code	The pin code is available for legacy Bluetooth modules that require a pin to pair the module. Although not used in current Bluetooth modules, the pin code is supported if needed. Default is 9611; must be 4-digits; range is 0000 to 9999.
Bluetooth Transmission Power	Designated transmission power (dbm) for the Bluetooth module. Lowering the transmission power reduces the effective range of the module. Default is 0; range is -6 to 4 dbm.



#### Notes:

- The ST Eye mobile app and the Bluetooth module may not be included with the PRO2.
- The ST Eye mobile app supports one concurrent session.
- Learn more about the Bluetooth monitoring solution (for either Android or iOS) at Server Technology's Technical Notes page [http://www.servertech.com/support/technical\\_library/technical\\_notes/](http://www.servertech.com/support/technical_library/technical_notes/)

## System > Branches

The **Branches** page provides the Branch Current Monitoring feature of the PRO2 to support up to six branches to measure, report, and alert (in Amps) per branch circuit for breaker and fuse errors.

The **Branches** pages allows setting multiple load levels for low/high warning/alarm values (A) for branch current thresholds, plus threshold hysteresis (A).

The page also sets sets SNMP Trap and Email notifications for branch events.

For dynamic monitoring of branch status and current, see the separate **Monitoring > Branches** page.

The screenshot shows the 'Branches' configuration page for a PRO2 Sentry Switched PDU. The page has a left sidebar with navigation options: Overview, Monitoring, Control, Configuration (selected), System, About, Bluetooth, Branches (selected), Cords, Features, Files, and Groups. The main content area is titled 'Branches' and contains a 'Configure branch settings' table. The table has columns for ID, Branch Name, SNMP Trap Notifications, and Email Notifications. Below the table are 'Apply' and 'Cancel' buttons, and a link for 'Branch Current Thresholds'.

ID	Branch Name	SNMP Trap Notifications	Email Notifications
AA1	AA:Branch_1	<input checked="" type="checkbox"/>	<input checked="" type="checkbox"/>
AA2	AA:Branch_2	<input type="checkbox"/>	<input checked="" type="checkbox"/>
BA1	BA:Branch_1	<input checked="" type="checkbox"/>	<input type="checkbox"/>
BA2	BA:Branch_2	<input checked="" type="checkbox"/>	<input checked="" type="checkbox"/>

Apply Cancel

[Branch Current Thresholds](#)

### About the branches:

- Branch names are not user-defined and cannot be changed.
- Branch values affect the setting on the OCP, if an OCP is connected to the PRO2. Not all PRO2 units will have an OCP; therefore, branch threshold range values will be affected by changing the current capacity on the OCP.

### To configure branch settings:

1. For each branch listed on the page, check (or uncheck) the SNMP Trap Notifications and/or Email Notifications checkboxes to enable (or disable) branch event notification for a specific branch.
2. Click **Apply**.

## Setting Branch Current Thresholds

From the Branches page, click the link Branch Current Thresholds to display the related thresholds edit page:

The screenshot shows the 'Branch Current Thresholds' configuration page. On the left is a navigation menu with categories like Overview, Monitoring, Control, Configuration, System, and Tools. The main content area is titled 'Branch Current Thresholds' and includes a 'Configure branch current hysteresis' section with a 'Hysteresis' input field set to 1.0 A. Below this is a 'Configure branch current thresholds' table with columns for ID, Branch Name, Low Alarm, Low Warning, High Warning, and High Alarm. The table lists four branches: AA1, AA2, BA1, and BA2, each with its respective current thresholds. At the bottom of the table are 'Apply' and 'Cancel' buttons, and a 'Branch Configuration' link.

ID	Branch Name	Low Alarm	Low Warning	High Warning	High Alarm
AA1	AA:Branch_1	0.0 A	0.0 A	14.0 A	16.0 A
AA2	AA:Branch_2	0.0 A	0.0 A	14.0 A	16.0 A
BA1	BA:Branch_1	0.0 A	0.0 A	14.0 A	16.0 A
BA2	BA:Branch_2	0.0 A	0.0 A	14.0 A	16.0 A
		All A	All A	All A	All A

### To set branch current thresholds:

1. Set the threshold hysteresis value (in Amps). Hysteresis is the values between the event state and recovery. Provide 0.0 to 10.0A. Default is 1.0A.
2. Provide the current load (A) for low/high warning/alarm threshold for a displayed branch on the page. Valid range is between 0-max (Max Current) in **show branches** command.
3. Click **Apply**.

## System > Cords

The **Cords** page configures the single input power cord in the PRO2 hardware architecture that reports infeed data for the unit, allowing the setting of multiple cord threshold levels for power, apparent power, power factor, 3-phase out-of-balance, and threshold hysteresis.

The value for *nominal voltage* – the point where an alert is received – is established on the **Cords** page.

The Cords page also sets SNMP Trap and Email notifications for cord events.

For dynamic monitoring of cord status, related power data, and out-of-balance levels, see the separate **Monitoring > Cords** page.

ID	Cord Name	Inlet Type	Nominal Voltage	Current Capacity	SNMP Trap Notifications	Email Notifications	
AA	Master_Cord_A	L15-30P	208 V	30 A	<input checked="" type="checkbox"/>	<input checked="" type="checkbox"/>	
CA	Link2_Cord_A	L6-30P	208 V	30 A	<input checked="" type="checkbox"/>	<input checked="" type="checkbox"/>	
DA	Link3_Cord_A	L6-30P	208 V	30 A	<input checked="" type="checkbox"/>	<input checked="" type="checkbox"/>	
		<input type="text" value="All"/>	V	<input type="text" value="All"/>	A	All None	All None

[Cord Power Thresholds](#)  
[Cord Apparent Power Thresholds](#)  
[Cord Power Factor Thresholds](#)  
[Cord 3-Phase Out-Of-Balance Thresholds](#)

Links to additional Cords pages for setting power thresholds and 3-phase out-of-balance thresholds.

### To configure cord settings:

1. In the Cord Name field, provide a descriptive text name, from 0-32 characters. The ID is a system-assigned internal name and cannot be changed.
2. View the reported type of inlet displayed for the cord.
3. In the Nominal Voltage field, set the value (in Volts) to be the mid-point of the Monitoring graphs, so that nominal voltage is the point where you are alerted for an alarm. Range is 0-max (max is factory nominal voltage) in the **show cords** command.
4. Set the current load for the cord in the Current Capacity field. Range is 0-max (max is factory current capacity) in the **show cords** command.
5. For each cord listed, check (or uncheck) SNMP Trap Notifications and/or Email Notifications to enable/disable notifications for cord events.
6. Click **Apply**.



## Configuring Cord Power Thresholds

Click the power thresholds link at the bottom of the Cords page to display the configuration page:

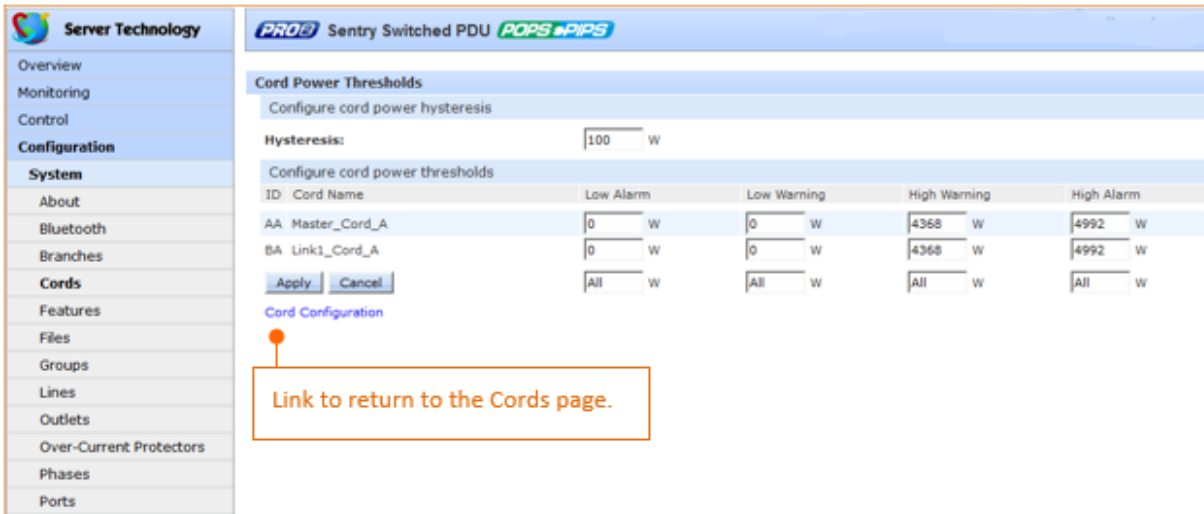

ID	Cord Name	Low Alarm	Low Warning	High Warning	High Alarm
AA	Master_Cord_A	0 W	0 W	4368 W	4992 W
BA	Link1_Cord_A	0 W	0 W	4368 W	4992 W

### To set power thresholds:

1. Provide the threshold hysteresis between event state and recovery (W). Range is 0-1000W; default is 100W.
2. Set the low/high alarm and low/high warning threshold values (W). Cord power does not include power factor. Range is min 0W; max is power capacity shown in **cstat** command.
3. Click **Apply**.

## Configuring Cord Apparent Power Thresholds

Click the apparent power thresholds link at the bottom of the Cords page to display the configuration page:

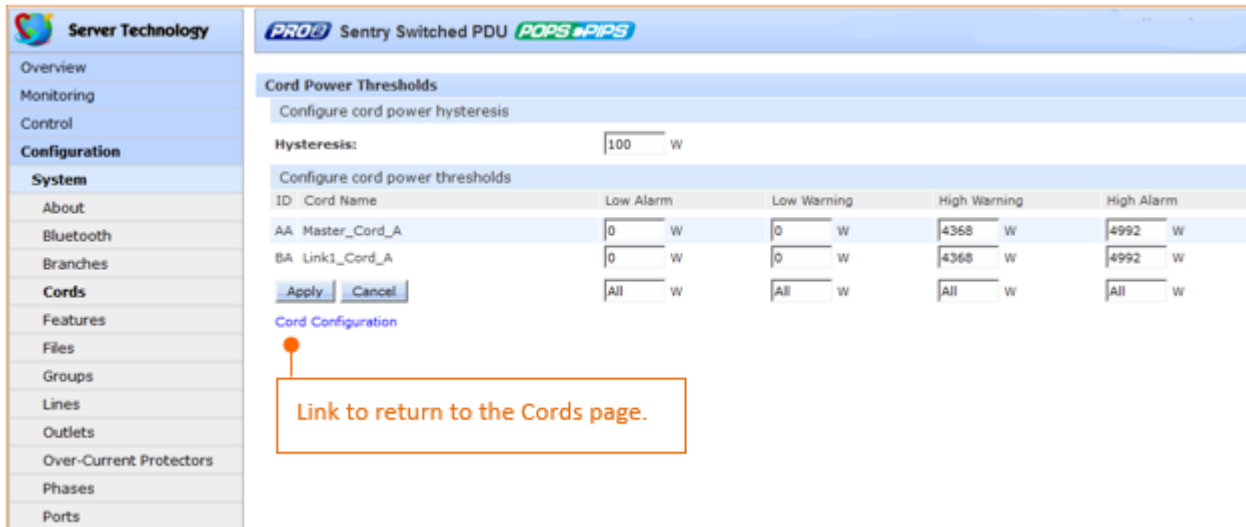

ID	Cord Name	Low Alarm	Low Warning	High Warning	High Alarm
AA	Master_Cord_A	0 W	0 W	4368 W	4992 W
BA	Link1_Cord_A	0 W	0 W	4368 W	4992 W

**To set apparent power thresholds:**

1. Provide the threshold hysteresis between event state and recovery (VA). Range is 0-1000VA; default is 100VA.
2. Set the low/high alarm and low/high warning threshold values (VA). Cord apparent power includes power factor. Range is min 0VA; max is power capacity shown in **cstat** command.
3. Click **Apply**.

**Configuring Cord Power Factor Thresholds**

Click the power factor thresholds link at the bottom of the Cords page to display the configuration page:

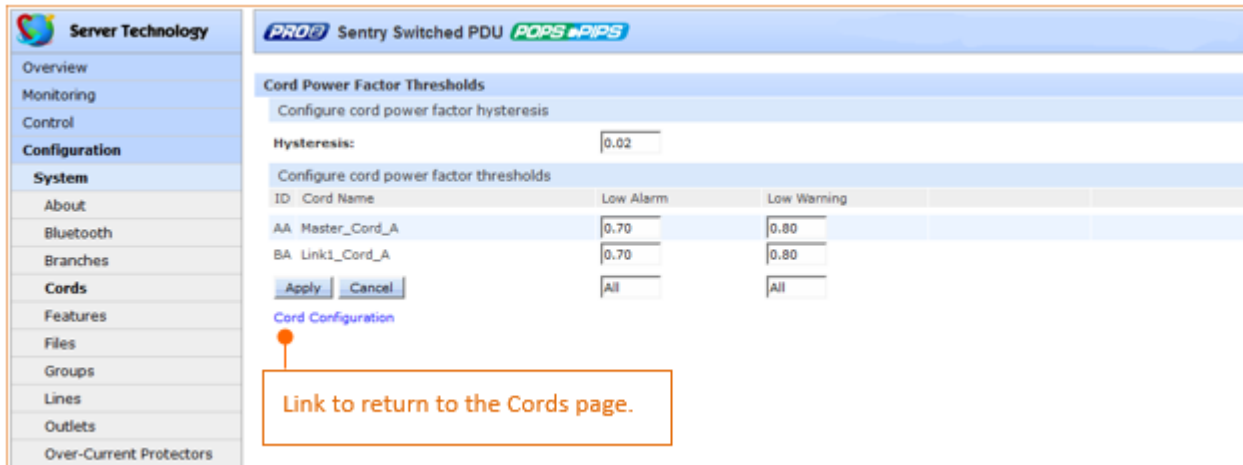

**To set power factor thresholds:**

1. Provide a numeric value for the threshold hysteresis between event state and recovery. Range is 0.0-0.20; default is 0.02.
2. Set numeric values for the low alarm/warning power factor thresholds. Range is min 0.00; max is 1.00.
3. Click **Apply**.

## Configuring 3-Phase Out-Of-Balance Thresholds

Click the out-of-balance link at the bottom of the Cords page to display the configuration page:

ID	Cord Name	High Warning	High Alarm
AA	Master_Cord_A	15 %	20 %
BA	Link1_Cord_A	15 %	20 %
		All %	All %

### To set out-of-balance factor thresholds:

1. Provide a percent for threshold hysteresis between event state and recovery. Range is 0-10%; default is 2%.
2. Set percent for high warning/alarm out-of-balance thresholds. Range is min 0%, max is 200%.
3. Click **Apply**.



### Notes:

- Out-of-balance is the percent power difference between phases of a cord.
- When a device with 3-phase input voltage is out-of-balance, efficiency is reduced and the unit is prevented from reaching maximum capacity, making it necessary to adjust distribution of the loads.

## System > Features

The **Features** page allows the activation of add-on features available from Server Technology.

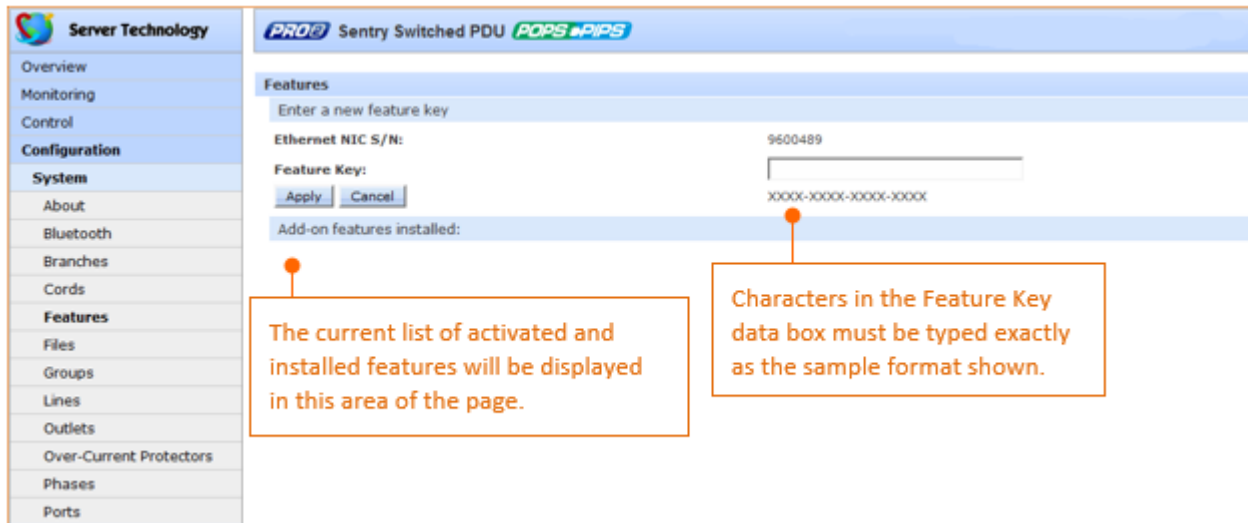

### **To activate a feature:**

1. In the Feature Key field, type the key provided by Server Technology.
2. Click **Apply**. A restart of the PRO2 is required after activating a feature.



**Note:** For more information about add-on features, such as Smart Load Shedding, contact your Server Technology sales representative.

## System > Files

The **Files** page provides a separate embedded file system to give quick access to system configuration files directly from the PRO2 GUI page, as well as the on-board and downloadable Sentry4-MIB and OID Tree for the PRO2, eliminating website MIB/OID downloads.



**Note:** CDU products continue to use the current Sentry3-MIB. The new Sentry4-MIB and its new OID tree are designed exclusively for the PRO2 products.

The page also allows GUI-based file uploads (without FTP) for system, configuration, and firmware versions. However, all PRO2 configuration/system files, MIB, and OID Tree can also be accessed via FTP at **Configuration > Network > FTP**.



**Note:** There is no CLI equivalent function for the GUI **Configuration > System > Files** page.

Date/Time	File	Size (Bytes)
09/07/2012 09:10 AM	dictionary.sti	2419
09/21/2016 03:00 PM	Sentry4.mib	154892
09/21/2016 03:00 PM	Sentry4OIDTree.txt	49424
11/04/2016 12:19 PM	config.bak	20920
11/04/2016 12:19 PM	config.ini	33185

### Uploading Files

Simple file upload without the need for FTP. Upload a firmware version or specific system configuration file by browsing and selecting the file in the Upload File field, and clicking **Upload**. A confirmation message displays to indicate the upload was successful and the system will require a restart.

### File View

The File View section of the page is a list of displayed files showing date/time stamp, file name, and file size. Several file types are shown in the list, described on the following pages:

## dictionary.sti

This dictionary file contains the defined and formatted RADIUS vendor-specific attributes (VSA), generated by, and available from, Server Technology.

The PRO2 is configured to recognize and use the configuration values in the file as specified by the network administrator, indicating to the RADIUS server that the defined attributes are based on Server Technology's unique enterprise vendor code. For more information about the dictionary file and RADIUS, see [About RADIUS Vendor-Specific Attributes \(VSA\)](#).

```
#
# dictionary.sti
#
VENDOR      STI      1718

#
# Attributes
#
ATTRIBUTE   STI-Access-Level  1  integer  STI
ATTRIBUTE   STI-Env-Mon      2  integer  STI
ATTRIBUTE   STI-Outlets     3  string   STI
ATTRIBUTE   STI-Groups    4  string   STI
ATTRIBUTE   STI-Ports    5  string   STI

      VALUE   STI-Access-Level  Admin      1
      VALUE   STI-Access-Level  Power-User 2
      VALUE   STI-Access-Level  User        3
      VALUE   STI-Access-Level  Reboot-Only 4
      VALUE   STI-Access-Level  On-Only    5
      VALUE   STI-Access-Level  View-Only  6

      VALUE   STI-Env-Mon  Yes  1
      VALUE   STI-Env-Mon  No   2
```

## sentry4.mib

For SNMP network monitoring, values from the PRO2 are reported using the new Sentry4-MIB. (Note that earlier PDU products continue to use the current Sentry3-MIB). The new Sentry4-MIB and its new OID tree are designed exclusively for PRO2 products.

Reported MIB objects in the PRO2 Sentry4-MIB are identified with a new “st4” prefix as part of the object name. You may be familiar with MIB objects for the PDU, for example, outletWakeupState. However, when the SNMP monitoring system displays a value for the MIB object name, st4outletWakeupState, based on the “st4” prefix in the name, you will recognize that the reported value is coming from a PRO2 unit, not from an earlier PDU product.

The Sentry4-MIB and OID tree for the PRO2 can be accessed on-board in the GUI via **Configuration > System > Files**, or accessed by using the Server Technology FTP site the same way as with the Sentry3-MIB and OID tree for the earlier PDU products.

```
--
-- Copyright(C) 2003-2014 Server Technology, Inc.
--

Sentry4-MIB DEFINITIONS ::= BEGIN

IMPORTS
    MODULE-IDENTITY, enterprises, Integer32,
    OBJECT-TYPE, NOTIFICATION-TYPE          FROM SNMPv2-SMI
    OBJECT-GROUP, NOTIFICATION-GROUP, MODULE-COMPLIANCE FROM SNMPv2-CONF
    TEXTUAL-CONVENTION, DisplayString       FROM SNMPv2-TC;

sentry4 MODULE-IDENTITY
    LAST-UPDATED "201412231130Z" -- 23 December 2014
    ORGANIZATION "Server Technology, Inc."
    CONTACT-INFO
        "Server Technology, Inc.
        1040 Sandhill Road
        Reno, NV 89521
        Tel: (775) 284-2000
        Fax: (775) 284-2065
        Email: mibmaster@servertech.com"
    DESCRIPTION
        "This is the MIB module for the fourth generation of the
        Sentry product family. This includes the PRO2 series of
        Smart and Switched Cabinet Distribution Unit (CDU) and
        Power Distribution Unit (PDU) products."
    REVISION "201412231130Z" -- 23 December 2014
    DESCRIPTION
        "Initial release."
    ::= { serverTech 4 }
```

## sentry4OIDTree.txt

The Sentry4OIDTree is the new OID tree structure that identifies PRO2 data objects for SNMP network monitoring. The Sentry4OIDTree is not backward-compatible with the Sentry3OIDTree.

Continue to use the Sentry3OIDTree for SNMP network monitoring of PDU products, and use the Sentry4OIDTree exclusively for PRO2 products.

```
serverTech Sentry4-MIB Object-Id Tree
-- created from sentry4 (201412231130Z)

<unit> = st4UnitIndex, 1 to 6 per system
<cord> = st4InputCordIndex, 1 to 4 per unit
<line> = st4LineIndex, 1 to 4 per cord
<phase> = st4PhaseIndex, 1 to 6 per cord
<ocp> = st4OcpIndex, 1 to 64 per cord
<branch> = st4BranchIndex, 1 to 64 per cord
<outlet> = st4OutletIndex, 1 to 128 per cord
<temp> = st4TempSensorIndex, 1 to 2 per unit
<humid> = st4HumidSensorIndex, 1 to 2 per unit
<water> = st4WaterSensorIndex, 1 per unit
<cc> = st4CcSensorIndex, 1 to 4 per unit
<adc> = st4AdcSensorIndex, 1 per unit

r- = read-only
rw = read-write
-- = not accessible

serverTech(enterprises 1718) .1.3.6.1.4.1.1718
|
+--sentry4(1.3.6.1.4.1.1718.4) +- .4
|
| +--st4Objects(1) +- .1
| |
| | +--st4System(1) +- .1
| | |
| | | +--st4SystemConfig(1) +- .1
| | | |
| | | | +-- r- st4SystemProductName(1) +- .1 .0
| | | | +-- rw st4SystemLocation(2) +- .2 .0
| | | | +-- r- st4SystemFirmwareVersion(3) +- .3 .0
| | | | +-- r- st4SystemFirmwareBuildInfo(4) +- .4 .0
| | | | +-- r- st4SystemNICSerialNumber(5) +- .5 .0
| | | | +-- r- st4SystemNICHardwareInfo(6) +- .6 .0
| | | | +-- r- st4SystemFeatures(10) +- .10 .0
| | | | +-- rw st4SystemFeatureKey(11) +- .11 .0
| | | | +-- r- st4SystemConfigModifiedCount(20) +- .20 .0
| | | | +-- r- st4SystemUnitCount(21) +- .21 .0
```

## config.bak (or \*.bak)

This configuration backup file (firmware version 8.0x or later), when uploaded, restores a PRO2 unit, including network, SNTP, and FTP settings.

User-configuration values are restored, **except**:

- DHCP/IP values in network settings
- SNAP password
- SNMP sysName (unless restoring to the same unit from which the backup came, based on NIC serial number, in which case the sysName is restored)
- User-loaded x-509 certificate and key
- Factory-configuration values, for example NIC serial number and profile, are not backed up or restored.



## System > Groups

The **Groups** page lets the administrator create and name a new outlet group and assign to the group access rights to individual (or all) outlets. For dynamic monitoring of outlets assigned to a group, see the separate **Monitoring > Groups** page.

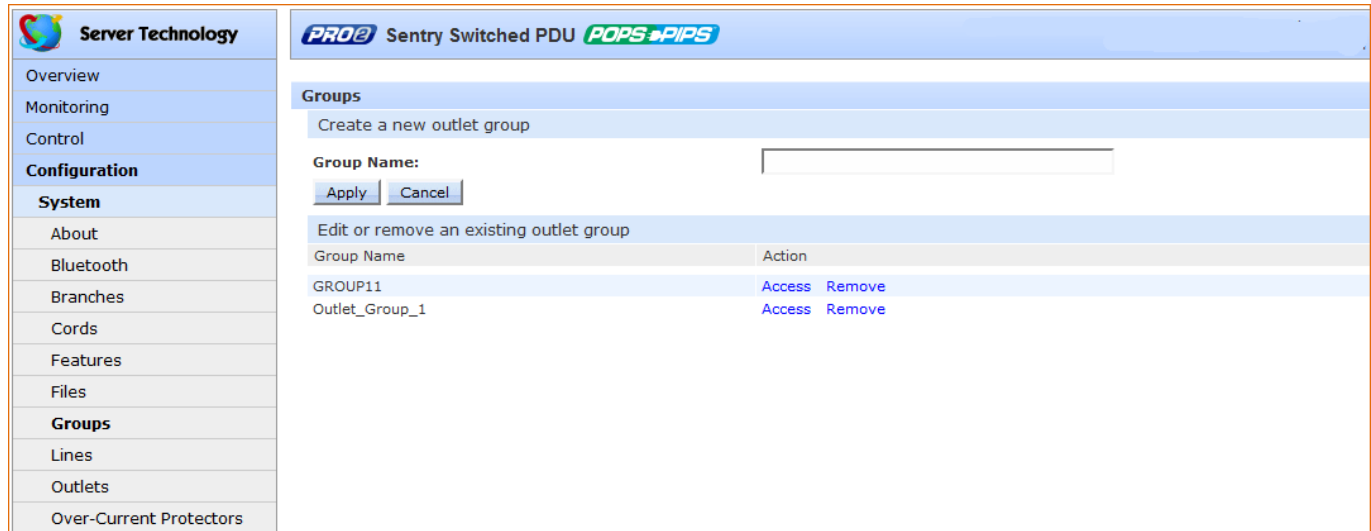

The screenshot shows the configuration interface for a PRO2 Sentry Switched PDU. On the left is a navigation menu with categories like Server Technology, Configuration, and System. The main area is titled 'Groups' and has two sections: 'Create a new outlet group' with a text input field and 'Apply'/'Cancel' buttons, and 'Edit or remove an existing outlet group' with a table of existing groups.

Group Name	Action
GROUP11	<a href="#">Access</a> <a href="#">Remove</a>
Outlet_Group_1	<a href="#">Access</a> <a href="#">Remove</a>

### To create a new outlet group:

1. In the Group Name field, type the new name for the outlet group.
2. Click **Apply**. The newly added name displays in the lower part of the page in a list of group names for editing or removing.

### To grant individual outlet access rights to an outlet group:

1. For the group name displayed in the list, click the Access link. The Group Access page displays to allow granting access rights to individual outlets by checking corresponding outlet checkboxes (or unchecking a checkbox to deny rights).
2. Click **Apply**. Access rights are applied to the outlets for the outlet group.

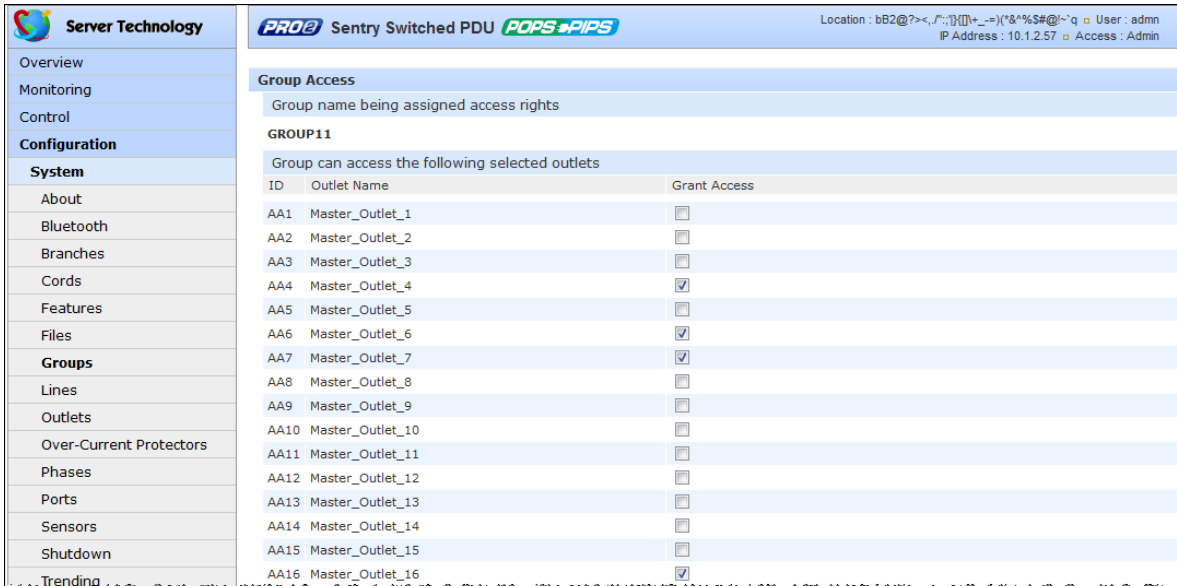

### To grant access rights to all outlets for an outlet group:

1. For the group name displayed in the list, click the Access link as described directly above.



2. At the bottom of the Group Access page, click the All link to grant access to all outlets listed on the page (or click the None link to deny access to all outlets listed).
3. Click **Apply**.

## System > Lines

The Lines page configures the separate area of the PRO2 cord architecture that reports current line load, allowing the setting of multiple line threshold levels, plus threshold hysteresis. The page also sets SNMP Trap and Email notifications for line events.

For dynamic monitoring of line status and current, see the separate **Monitoring > Lines** page.

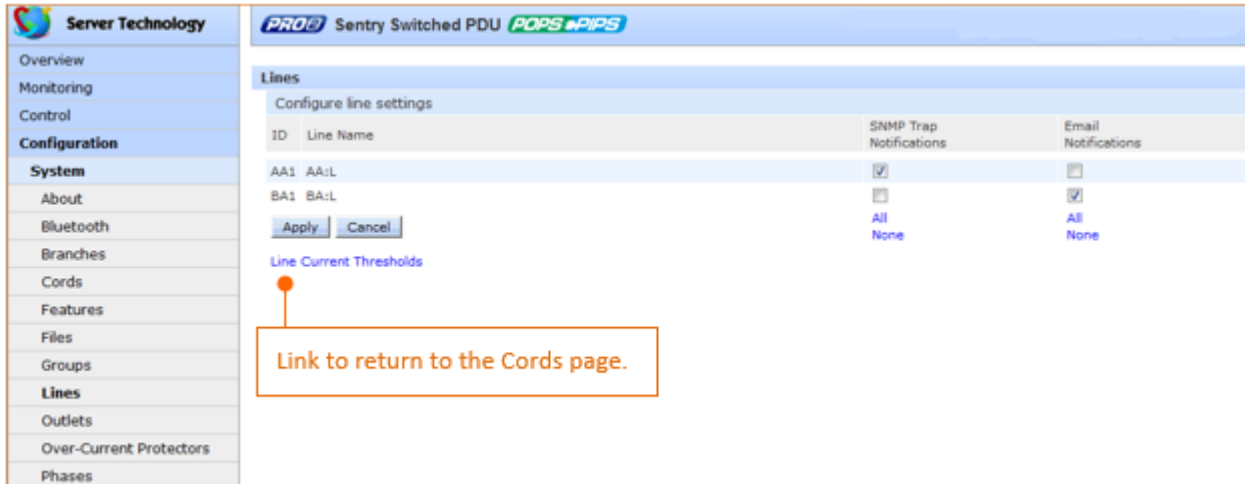

The screenshot shows the 'Lines' configuration page for a PRO2 Sentry Switched PDU. The page has a left sidebar with navigation options: Overview, Monitoring, Control, Configuration, System, About, Bluetooth, Branches, Cords, Features, Files, Groups, Lines, Outlets, Over-Current Protectors, and Phases. The main content area is titled 'Lines' and contains a 'Configure line settings' section. Below this is a table with the following data:

ID	Line Name	SNMP Trap Notifications	Email Notifications
AA1	AA:L	<input checked="" type="checkbox"/>	<input type="checkbox"/>
BA1	BA:L	<input type="checkbox"/>	<input checked="" type="checkbox"/>

Below the table are 'Apply' and 'Cancel' buttons. Underneath is a link for 'Line Current Thresholds' with a red dot icon. A callout box with an orange border points to this link and contains the text: 'Link to return to the Cords page.'

### To configure line settings:

1. For each line listed, check (or uncheck) SNMP Trap Notifications and/or Email Notifications to enable/disable notifications for line events. To enable (or disable) all lines for SNMP Trap or Email notifications, click All (or None).
2. Click **Apply**.



**Note:** The format of PRO2 line names is a standard and fixed naming structure and cannot be edited.

Example of line names:

AA:L1, AA:L2, AA:L3, AA:N (Master unit: Lines 1, 2, 3, and Line N for neutral)

BA:L1, BA:L2, BA:L3, BA:N (Link unit: Lines 1, 2, 3, and Line N for neutral)

## Configuring Line Current Thresholds

Click the thresholds link at the bottom of the Lines page to display the configuration page:

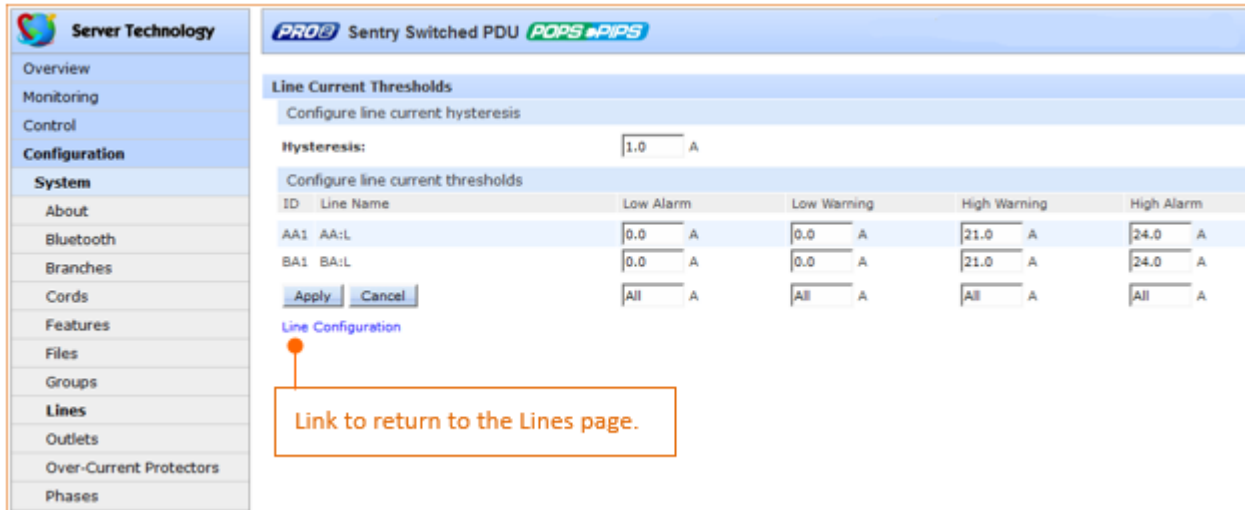

ID	Line Name	Low Alarm	Low Warning	High Warning	High Alarm
AA1	AA:L	0.0 A	0.0 A	21.0 A	24.0 A
BA1	BA:L	0.0 A	0.0 A	21.0 A	24.0 A
	All	All A	All A	All A	All A

### To set line current thresholds:

1. Provide the threshold hysteresis between event state and recovery (A). Range is 0.0-10.0A; default is 1.0A.
2. Set the low/high alarm and low/high warning current load threshold values (A). Range is min 0A; max is current limit displayed in **show lines** command.
3. Click **Apply**.

## System > Outlets

The **Outlets** page allows configuration of global outlet parameters and outlet shutdown options, including the setting of multiple threshold levels for outlet current, outlet power, and outlet power factor, plus the threshold hysteresis. The page also sets sets SNMP Trap and Email notifications for outlet events.

For outlet management: the issuing of On, Off, and Reboot commands on individual outlets and all outlets globally, see the separate **Control > Outlets** page and **Control > Groups** page.

For dynamic monitoring of outlet status, see the separate **Monitoring > Outlets** page.

For configuring and the assignment of outlets to user-defined outlet groups, see the separate **Configuration > Groups** page.

**Server Technology** | **PRO2 Sentry Switched PDU** | **POPS+PIPS**

**Outlets**  
Configure global outlet options

Sequence Interval (seconds):   
 Reboot Delay (seconds):   
 State Change Logging:  Enable

List outlets in selected unit  
 Selected Unit:

Configure unit outlet options

ID	Outlet Name	Socket Type	Extra On Delay	Wake Up State	Locked / No Control	SNMP Trap Notifications	Email Notifications
AA1	Master_Outlet_1	C19	0 sec	On	<input type="checkbox"/>	<input checked="" type="checkbox"/>	<input checked="" type="checkbox"/>
AA2	Master_Outlet_2	C13	0 sec	On	<input type="checkbox"/>	<input checked="" type="checkbox"/>	<input type="checkbox"/>
AA3	Master_Outlet_3	C13	0 sec	On	<input type="checkbox"/>	<input type="checkbox"/>	<input checked="" type="checkbox"/>
AA4	Master_Outlet_4	C13	0 sec	On	<input type="checkbox"/>	<input checked="" type="checkbox"/>	<input checked="" type="checkbox"/>
AA5	Master_Outlet_5	C13	0 sec	On	<input type="checkbox"/>	<input checked="" type="checkbox"/>	<input checked="" type="checkbox"/>
AA6	Master_Outlet_6	C13	0 sec	On	<input checked="" type="checkbox"/>	<input checked="" type="checkbox"/>	<input checked="" type="checkbox"/>

AA16	Master_Outlet_16	C13	0 sec	On	<input type="checkbox"/>	<input checked="" type="checkbox"/>	<input checked="" type="checkbox"/>
AA17	Master_Outlet_17	C13	0 sec	On	<input type="checkbox"/>	<input checked="" type="checkbox"/>	<input checked="" type="checkbox"/>
AA18	Master_Outlet_18	C13	0 sec	On	<input type="checkbox"/>	<input checked="" type="checkbox"/>	<input checked="" type="checkbox"/>
AA19	Master_Outlet_19	C13	0 sec	On	<input type="checkbox"/>	<input checked="" type="checkbox"/>	<input checked="" type="checkbox"/>
AA20	Master_Outlet_20	C19	0 sec	On	<input type="checkbox"/>	<input checked="" type="checkbox"/>	<input checked="" type="checkbox"/>
AA21	Master_Outlet_21	C19	0 sec	On	<input type="checkbox"/>	<input checked="" type="checkbox"/>	<input checked="" type="checkbox"/>
AA22	Master_Outlet_22	C13	0 sec	On	<input type="checkbox"/>	<input checked="" type="checkbox"/>	<input checked="" type="checkbox"/>
AA23	Master_Outlet_23	C13	0 sec	On	<input type="checkbox"/>	<input checked="" type="checkbox"/>	<input checked="" type="checkbox"/>
AA24	Master_Outlet_24	C13	0 sec	On	<input type="checkbox"/>	<input checked="" type="checkbox"/>	<input checked="" type="checkbox"/>
AA25	Master_Outlet_25	C13	0 sec	On	<input type="checkbox"/>	<input checked="" type="checkbox"/>	<input checked="" type="checkbox"/>
AA26	Master_Outlet_26	C13	0 sec	On	<input type="checkbox"/>	<input checked="" type="checkbox"/>	<input checked="" type="checkbox"/>
AA27	Master_Outlet_27	C13	0 sec	On	<input type="checkbox"/>	<input checked="" type="checkbox"/>	<input checked="" type="checkbox"/>
AA28	Master_Outlet_28	C13	0 sec	On	<input type="checkbox"/>	<input checked="" type="checkbox"/>	<input checked="" type="checkbox"/>
AA29	Master_Outlet_29	C13	0 sec	On	<input type="checkbox"/>	<input checked="" type="checkbox"/>	<input checked="" type="checkbox"/>
AA30	Master_Outlet_30	C19	0 sec	On	<input type="checkbox"/>	<input checked="" type="checkbox"/>	<input checked="" type="checkbox"/>

Apply Cancel

Outlet Current Thresholds  
 Outlet Power Thresholds  
 Outlet Power Factor Thresholds

Links to outlet threshold configuration pages.

### To configure outlet options:

1. Set the Sequence Delay (in seconds) to determine the delay between turning on the outlets. Range is 0-15 seconds.
2. Set the Reboot Delay (in seconds) to set an extra on delay when rebooting an outlet.
3. Check to enable the State Change Logging feature. This option shows outlet state change as a reported event in all system/debug logs.
4. In the Outlet Name field, provide a descriptive text name, from 0-32 characters. The ID is a system-assigned internal name and cannot be changed

5. View the reported type of socket displayed for the outlet.
6. In the Extra On Delay field, for a specific outlet, set the value (in seconds) for an extra delay when turning on the outlet. Range is 0-900 seconds.
7. From the drop-down menu, select the On, Off, Last option for the wakeup state of the outlet. Wakeup state sets the default outlet control state after system power up. The option Last is the last known power state of the outlet.
8. For the Locked/No Control checkbox, check (to lock the outlet) or uncheck (to unlock the outlet). The Locked feature determines if control actions (on, off, reboot) are enabled/disabled for the outlet after the wakeup state is applied. When an outlet is configured in the locked state, the outlet locks at its current control state (on or off), and the outlet control state changes to Locked On or Locked Off.



**Note:** The locked outlet will not be affected by group actions or Smart Load Shedding actions. SNMP and CLI control actions will be ignored for a locked outlet.

9. For each outlet listed, check (or uncheck) SNMP Trap Notifications and/or Email Notifications to enable (or disable) notifications for outlet events.
10. Click **Apply**.

### Configuring Outlet Current Thresholds

Click the current thresholds link at the bottom of the Outlets page to display the configuration page:

Server Technology		Hysteresis:		Configure outlet current thresholds									
		0.0 A		ID	Outlet Name	Low Alarm		Low Warning		High Warning		High Alarm	
Overview		AA1	Master_Outlet_1	0.0	A	0.0	A	14.0	A	16.0	A		
Monitoring		AA2	Master_Outlet_2	0.0	A	0.0	A	10.5	A	12.0	A		
Control		AA3	Master_Outlet_3	0.0	A	0.0	A	10.5	A	12.0	A		
<b>Configuration</b>		AA4	Master_Outlet_4	0.0	A	0.0	A	10.5	A	12.0	A		
<b>System</b>		AA5	Master_Outlet_5	0.0	A	0.0	A	10.5	A	12.0	A		
About		AA6	Master_Outlet_6	0.0	A	0.0	A	10.5	A	12.0	A		
Bluetooth		AA7	Master_Outlet_7	0.0	A	0.0	A	10.5	A	12.0	A		
Branches		AA8	Master_Outlet_8	0.0	A	0.0	A	10.5	A	12.0	A		
Cords		AA9	Master_Outlet_9	0.0	A	0.0	A	10.5	A	12.0	A		
Features		AA10	Master_Outlet_10	0.0	A	0.0	A	14.0	A	16.0	A		
Files		AA11	Master_Outlet_11	0.0	A	0.0	A	14.0	A	16.0	A		
Groups		AA12	Master_Outlet_12	0.0	A	0.0	A	10.5	A	12.0	A		
Lines		AA13	Master_Outlet_13	0.0	A	0.0	A	10.5	A	12.0	A		
<b>Outlets</b>		AA14	Master_Outlet_14	0.0	A	0.0	A	10.5	A	12.0	A		
Over-Current Protectors		AA15	Master_Outlet_15	0.0	A	0.0	A	10.5	A	12.0	A		
Phases													

#### To set outlet current thresholds:

1. Provide threshold hysteresis between event state and recovery (A). Range is 0.0-10.0A; default is 1.0A.
2. Set the low/high alarm and low/high warning threshold values (A) for outlet current load. Range is min 0.0A; max is max current shown in **show outlets** command.
3. Click **Apply**.

## Configuring Outlet Power Thresholds

Click the outlet power thresholds link at the bottom of the Outlets page to display the configuration page:

The screenshot shows the configuration page for the PRO2 Sentry Switched PDU. The page title is "Outlet Power Thresholds" and it includes a sub-section "Configure outlet power hysteresis" with a text input field set to "0" W. Below this is another sub-section "Configure outlet power thresholds" which contains a table with 13 rows of outlet configurations. Each row includes an ID, Outlet Name, and four threshold columns: Low Alarm, Low Warning, High Warning, and High Alarm. Each threshold column has a text input field and a unit "W".

ID	Outlet Name	Low Alarm	Low Warning	High Warning	High Alarm
AA1	Master_Outlet_1	0 W	0 W	2912 W	3328 W
AA2	Master_Outlet_2	0 W	0 W	2184 W	2496 W
AA3	Master_Outlet_3	0 W	0 W	2184 W	2496 W
AA4	Master_Outlet_4	0 W	0 W	2184 W	2496 W
AA5	Master_Outlet_5	0 W	0 W	2184 W	2496 W
AA6	Master_Outlet_6	0 W	0 W	2184 W	2496 W
AA7	Master_Outlet_7	0 W	0 W	2184 W	2496 W
AA8	Master_Outlet_8	0 W	0 W	2184 W	2496 W
AA9	Master_Outlet_9	0 W	0 W	2184 W	2496 W
AA10	Master_Outlet_10	0 W	0 W	2912 W	3328 W
AA11	Master_Outlet_11	0 W	0 W	2912 W	3328 W
AA12	Master_Outlet_12	0 W	0 W	2184 W	2496 W
AA13	Master_Outlet_13	0 W	0 W	2184 W	2496 W

### To set outlet power thresholds:

1. Provide the threshold hysteresis between event state and recovery (W). Range is 0-1000W; default is 10W.
2. Set the low/high alarm and low/high warning threshold values (W) for outlet power (without power factor). Range is min 0W, max is power capacity in **ostat** details command.
3. Click **Apply**.

## Configuring Outlet Power Factor Thresholds

Click the outlet power factor thresholds link at the bottom of the Outlets page to display the configuration page:

The screenshot shows the configuration page for the Sentry Switched CDU. The left sidebar contains a navigation menu with categories like Overview, Monitoring, Control, Configuration, System, and Outlets. The main content area is titled 'Outlet Power Factor Thresholds' and includes a sub-section for 'Configure outlet power factor hysteresis' with a text input field set to '0.02'. Below this is a table for 'Configure outlet power factor thresholds' with columns for ID, Outlet Name, Low Alarm, and Low Warning. The table lists 20 outlets, each with a Low Alarm value of 0.70 and a Low Warning value of 0.80.

ID	Outlet Name	Low Alarm	Low Warning
AA1	Master_Outlet_1	0.70	0.80
AA2	Master_Outlet_2	0.70	0.80
AA3	Master_Outlet_3	0.70	0.80
AA4	Master_Outlet_4	0.70	0.80
AA5	Master_Outlet_5	0.70	0.80
AA6	Master_Outlet_6	0.70	0.80
AA7	Master_Outlet_7	0.70	0.80
AA8	Master_Outlet_8	0.70	0.80
AA9	Master_Outlet_9	0.70	0.80
AA10	Master_Outlet_10	0.70	0.80
AA11	Master_Outlet_11	0.70	0.80
AA12	Master_Outlet_12	0.70	0.80
AA13	Master_Outlet_13	0.70	0.80
AA14	Master_Outlet_14	0.70	0.80
AA15	Master_Outlet_15	0.70	0.80
AA16	Master_Outlet_16	0.70	0.80
AA17	Master_Outlet_17	0.70	0.80
AA18	Master_Outlet_18	0.70	0.80
AA19	Master_Outlet_19	0.70	0.80
AA20	Master_Outlet_20	0.70	0.80

### To set outlet power factor thresholds:

1. Provide a numeric value for the threshold hysteresis between event state and recovery. Range is 0.0-0.20; default is 0.02.
2. Set numeric values for the low alarm/warning outlet power factor thresholds. Range is min 0.00; max is 1.00.
3. Click **Apply**.



## System > Over-Current Protectors (OCPs)

The **Over-Current Protectors** page configures current load settings for each OCP connected to the PRO2 unit as a standard and separate area of the PRO2 architecture. The page also sets sets SNMP Trap and Email notifications for OCP events.

For dynamic monitoring of OCP status, see the separate **Monitoring > Over-Current Protectors** page. A failed OCP status (for either Switched or Smart PRO2 products) is reported on the monitoring page.

The screenshot shows the configuration page for Over-Current Protectors on a PRO2 Sentry Switched PDU. The page has a left-hand navigation menu with categories like Overview, Monitoring, Control, Configuration, System, About, Bluetooth, Branches, Cords, Features, Files, Groups, Lines, Outlets, Over-Current Protectors, Phases, and Ports. The main content area is titled 'Over-Current Protectors' and includes a sub-header 'Configure over-current protector settings'. Below this is a table with columns for ID, OCP Name, Type, Current Capacity, SNMP Trap Notifications, and Email Notifications. The table lists four OCPs: AA1 AA:Breaker\_1, AA2 AA:Breaker\_2, BA1 BA:Breaker\_1, and BA2 BA:Breaker\_2. Each row has input fields for current capacity (set to 20 A) and checkboxes for notifications. At the bottom of the table are 'Apply' and 'Cancel' buttons.

ID	OCP Name	Type	Current Capacity	SNMP Trap Notifications	Email Notifications
AA1	AA:Breaker_1	Breaker	20 A	<input checked="" type="checkbox"/>	<input checked="" type="checkbox"/>
AA2	AA:Breaker_2	Breaker	20 A	<input checked="" type="checkbox"/>	<input checked="" type="checkbox"/>
BA1	BA:Breaker_1	Breaker	20 A	<input type="checkbox"/>	<input checked="" type="checkbox"/>
BA2	BA:Breaker_2	Breaker	20 A	<input checked="" type="checkbox"/>	<input type="checkbox"/>
			All A	All None	All None

### To configure the OCP:

1. View the reported type of OCP as displayed on the page, either breaker or fuse.
2. Set the Current Capacity (A) for the OCP as its maximum current load. Range is 1-max current as displayed in the **show ocp** command.
3. For each outlet listed, check (or uncheck) SNMP Trap Notifications and/or Email Notifications to enable (or disable) notifications for OCP events.
4. Click **Apply**.

## System > Phases

The **Phases** page configures multiple threshold levels for phase voltage and power factor, plus threshold hysteresis (for AC products only). The page also sets sets SNMP Trap and Email notifications for phase events.

For dynamic monitoring of phase status, voltage, and power factor, see the separate **Monitoring > Phases** page.

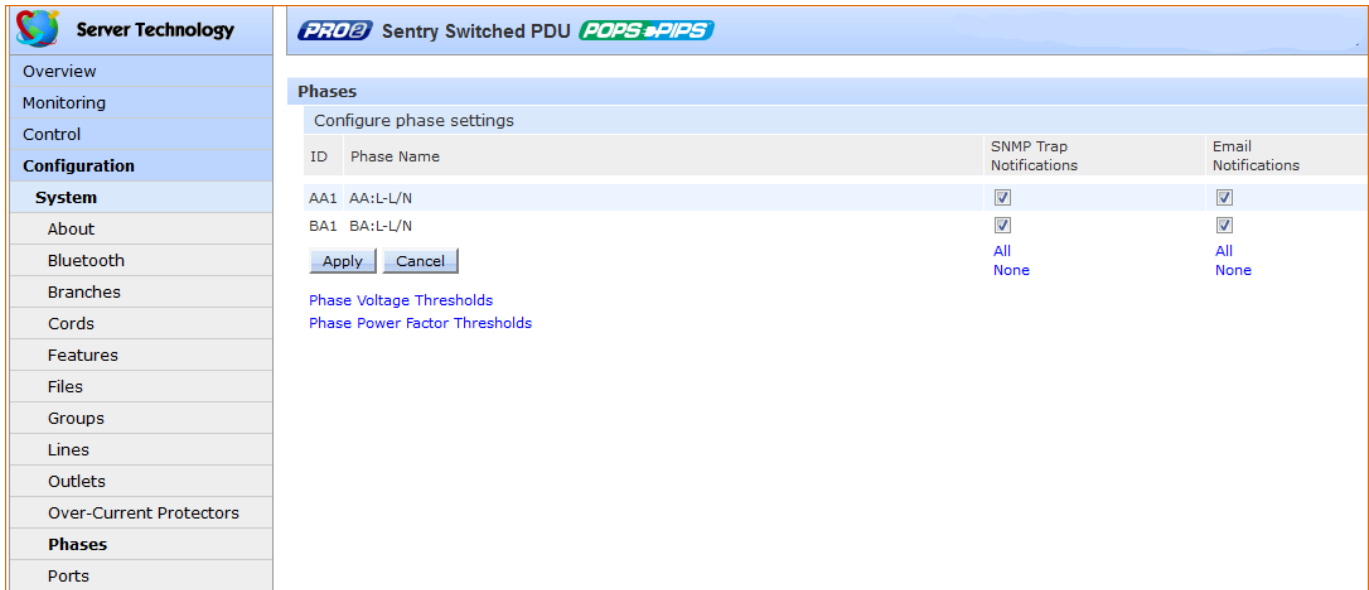

The screenshot shows the 'Phases' configuration page for a 'PRO2 Sentry Switched PDU'. The page is titled 'Configure phase settings' and contains a table with the following columns: ID, Phase Name, SNMP Trap Notifications, and Email Notifications. Two phases are listed: AA1 (AA:L-L/N) and BA1 (BA:L-L/N). Both have checkboxes for both notification types, which are currently checked. Below the table are 'Apply' and 'Cancel' buttons, and links for 'Phase Voltage Thresholds' and 'Phase Power Factor Thresholds'.

ID	Phase Name	SNMP Trap Notifications	Email Notifications
AA1	AA:L-L/N	<input checked="" type="checkbox"/>	<input checked="" type="checkbox"/>
BA1	BA:L-L/N	<input checked="" type="checkbox"/>	<input checked="" type="checkbox"/>

### To set phase event notifications:

1. For each phase listed, check (or uncheck) SNMP Trap Notifications and/or Email Notifications to enable (or disable) notifications for phase events.
2. Click **Apply**.

## Configuring Phase Voltage Thresholds

Click the phase voltage thresholds link at the bottom of the Phases page to display the configuration page:

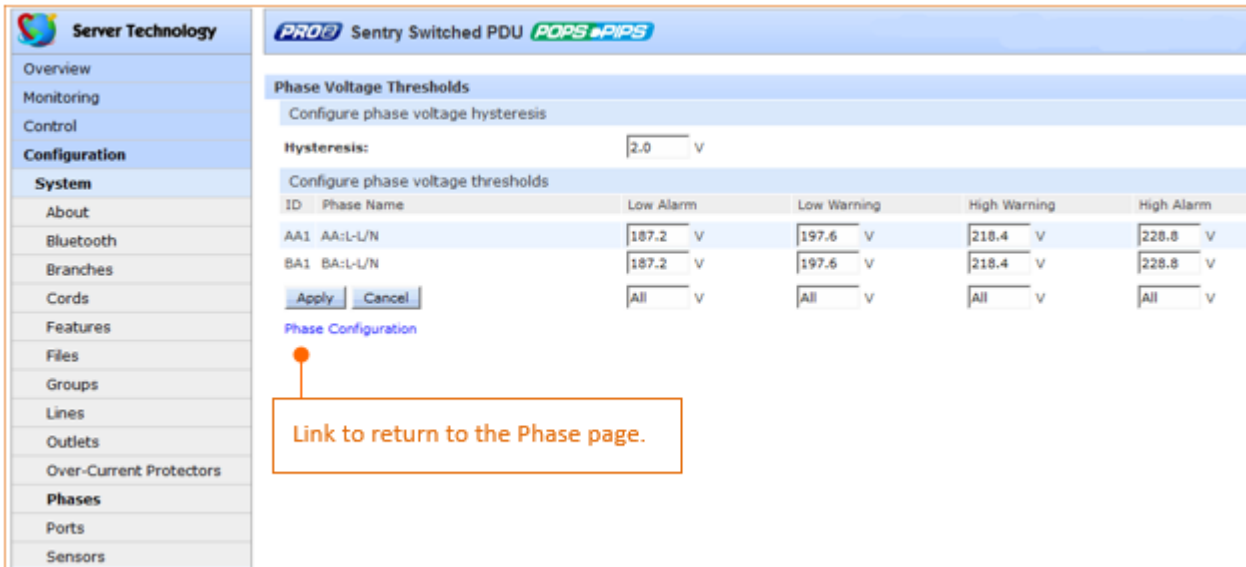

The screenshot shows the configuration page for a Sentry Switched PDU. The left sidebar contains a navigation menu with categories like Overview, Monitoring, Control, Configuration, System, and Phases. The main content area is titled 'Phase Voltage Thresholds' and includes a 'Configure phase voltage hysteresis' section with a text input field set to '2.0' V. Below this is a 'Configure phase voltage thresholds' table with columns for ID, Phase Name, Low Alarm, Low Warning, High Warning, and High Alarm. The table contains two rows: AA1 AA:L-L/N and BA1 BA:L-L/N, with values for each threshold. There are 'Apply' and 'Cancel' buttons below the table. A 'Phase Configuration' link is also visible. A red callout box points to the 'Phase Configuration' link with the text 'Link to return to the Phase page.'

ID	Phase Name	Low Alarm	Low Warning	High Warning	High Alarm
AA1	AA:L-L/N	187.2 V	197.6 V	218.4 V	228.8 V
BA1	BA:L-L/N	187.2 V	197.6 V	218.4 V	228.8 V

### To set phase voltage power thresholds:

1. Provide the threshold hysteresis between event state and recovery (V). Range is 0.0-20.0V; default is 2.0V.
2. Set the low/high alarm and low/high warning threshold values(V) for phase voltage.
3. Click **Apply**.



**Note:** The range of phase voltage minimum and maximum values varies by product. To verify the nominal phase voltage by product, issue the CLI command **set cord nomvolts**, for example:

```
Switched CDU: set cord nomvolts
                Cord name or ID: Master_Cord_A
                Cord nominal voltage (200-240 Volts):
```

## Configuring Phase Power Factor Thresholds

Click the phase power factor thresholds link at the bottom of the Phases page to display the configuration page:

**PRO2** Sentry Switched PDU **POPS** **PIPS**

### Phase Power Factor Thresholds

Configure phase power factor hysteresis

Hysteresis:

Configure phase power factor thresholds

ID	Phase Name	Low Alarm	Low Warning
AA1	AA:L-L/N	<input type="text" value="0.70"/>	<input type="text" value="0.80"/>
BA1	BA:L-L/N	<input type="text" value="0.70"/>	<input type="text" value="0.80"/>

[Phase Configuration](#)

Link to return to the Phase page.

### To set phase power factor thresholds:

1. Provide a numeric value for the threshold hysteresis between event state and recovery. Range is 0-0.20; default is 0.02.
2. Set numeric values for the low alarm/warning phase power factor thresholds. Range is min 0.00; max is 1.00.
3. Click **Apply**.

## System > Ports

The **Ports** page configures options for the external serial port on the PRO2 unit.

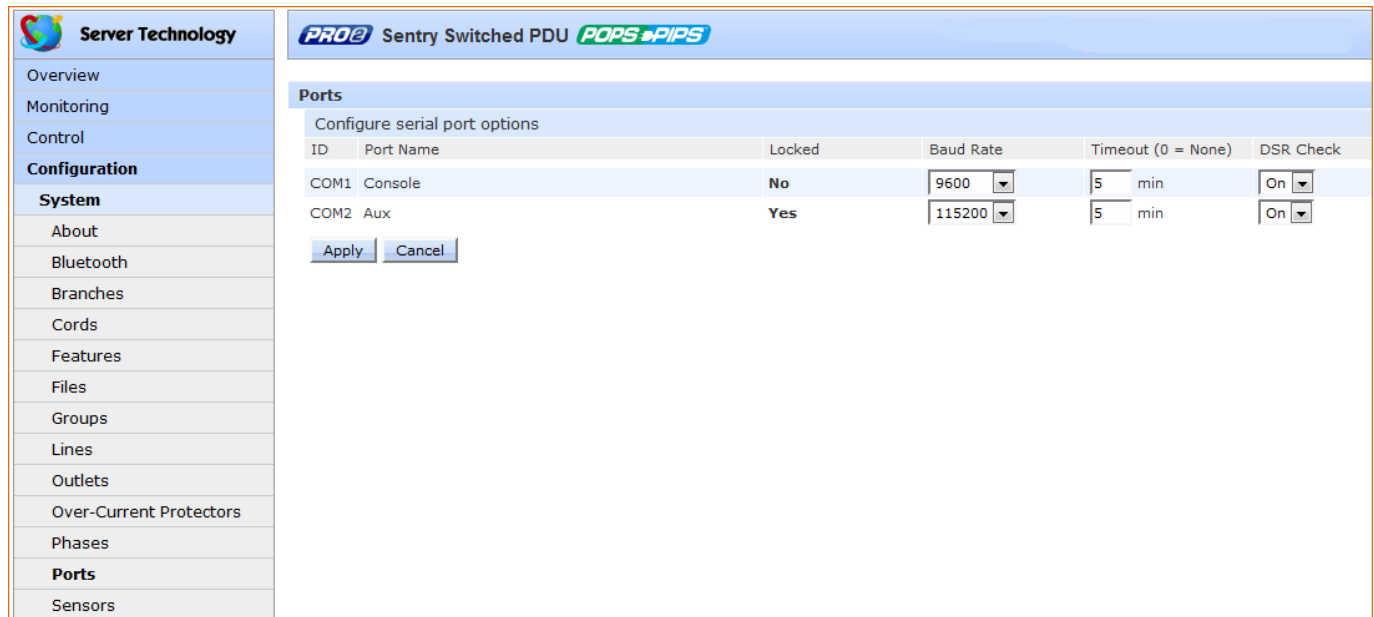

The screenshot shows the configuration interface for a PRO2 Sentry Switched PDU. The left sidebar contains a navigation menu with categories: Overview, Monitoring, Control, Configuration, System, About, Bluetooth, Branches, Cords, Features, Files, Groups, Lines, Outlets, Over-Current Protectors, Phases, Ports, and Sensors. The main content area is titled 'Ports' and includes a sub-header 'Configure serial port options'. Below this is a table with columns: ID, Port Name, Locked, Baud Rate, Timeout (0 = None), and DSR Check. The table contains two rows: COM1 Console (Locked: No, Baud Rate: 9600, Timeout: 5 min, DSR Check: On) and COM2 Aux (Locked: Yes, Baud Rate: 115200, Timeout: 5 min, DSR Check: On). At the bottom of the table are 'Apply' and 'Cancel' buttons.

ID	Port Name	Locked	Baud Rate	Timeout (0 = None)	DSR Check
COM1	Console	No	9600	5 min	On
COM2	Aux	Yes	115200	5 min	On

### To configure the serial port:

1. From the Baud Rate drop-down menu, select the data rate.
2. Set the Timeout value (in minutes) for the serial port inactivity timeout period. The timeout period defines the maximum period of inactivity before automatically closing the pass-thru session. Range is 0-60 (minutes); default is 5 minutes; setting the value to "0" disables the timeout.
3. From the DSR Check drop-down menu, select On or Off to enable or disable serial port active signal checking.
4. Click **Apply**.



#### Notes:

- Pass-Thru connections can only be initiated from the Command Line Interface (CLI) in a Telnet/SSH session.
- One concurrent Serial session is allowed. If the unit has two serial ports, then two simultaneous serial sessions will be supported.

## System > Sensors

The **Sensors** page configures multiple threshold levels for global temperature sensors and relative humidity sensors, plus threshold hysteresis. The page also determines the system-wide temperature scale and sets SNMP Trap and Email notifications for sensor events.

For dynamic monitoring of sensor temperature/humidity and operational status, see the separate **Monitoring > Sensors** page.

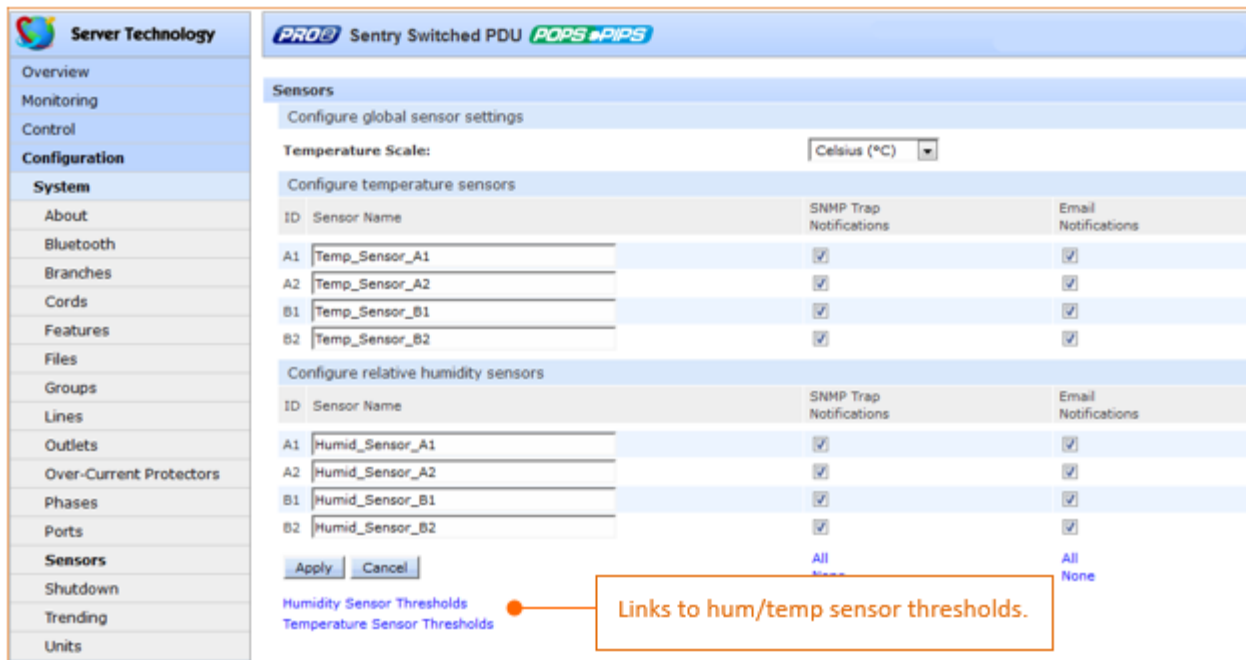

**Server Technology** | **PRO2** Sentry Switched PDU | **POPS** **PIPS**

### Sensors

Configure global sensor settings

Temperature Scale: Celsius (°C)

Configure temperature sensors

ID	Sensor Name	SNMP Trap Notifications	Email Notifications
A1	Temp_Sensor_A1	<input checked="" type="checkbox"/>	<input checked="" type="checkbox"/>
A2	Temp_Sensor_A2	<input checked="" type="checkbox"/>	<input checked="" type="checkbox"/>
B1	Temp_Sensor_B1	<input checked="" type="checkbox"/>	<input checked="" type="checkbox"/>
B2	Temp_Sensor_B2	<input checked="" type="checkbox"/>	<input checked="" type="checkbox"/>

Configure relative humidity sensors

ID	Sensor Name	SNMP Trap Notifications	Email Notifications
A1	Humid_Sensor_A1	<input checked="" type="checkbox"/>	<input checked="" type="checkbox"/>
A2	Humid_Sensor_A2	<input checked="" type="checkbox"/>	<input checked="" type="checkbox"/>
B1	Humid_Sensor_B1	<input checked="" type="checkbox"/>	<input checked="" type="checkbox"/>
B2	Humid_Sensor_B2	<input checked="" type="checkbox"/>	<input checked="" type="checkbox"/>

Apply Cancel

[Humidity Sensor Thresholds](#) | [Temperature Sensor Thresholds](#)

Links to hum/temp sensor thresholds.

### To configure global sensor settings:

1. From the Temperature Scale drop-down menu, select the desired system-wide scale as Celsius (°C) or Fahrenheit (°F).
2. In the Sensor Name field, provide a descriptive text name for individual temperature sensors and/or relative humidity sensors. The ID is a system-assigned internal name and cannot be changed.
3. For each sensor listed, check (or uncheck) SNMP Trap Notifications and/or Email Notifications to enable (or disable) notifications for sensor events.
4. Click **Apply**.

## Configuring Humidity Sensors Thresholds

Click the humidity sensor thresholds link at the bottom of the Sensors page to display the configuration page:

The screenshot shows the 'Humidity Sensor Thresholds' configuration page for a Sentry Switched PDU. The page includes a sidebar with navigation options like Overview, Monitoring, Control, Configuration, System, About, Bluetooth, Branches, Cords, Features, Files, Groups, Lines, Outlets, Over-Current Protectors, Phases, Ports, Sensors, and Shutdown. The main configuration area has a 'Hysteresis' input set to 2. Below it is a table for configuring humidity sensor thresholds.

ID	Humidity Sensor Name	Low Alarm	Low Warning	High Warning	High Alarm
A1	Humid_Sensor_A1	5 % RH	10 % RH	90 % RH	95 % RH
A2	Humid_Sensor_A2	5 % RH	10 % RH	90 % RH	95 % RH
B1	Humid_Sensor_B1	5 % RH	10 % RH	90 % RH	95 % RH
B2	Humid_Sensor_B2	5 % RH	10 % RH	90 % RH	95 % RH
		All % RH	All % RH	All % RH	All % RH

Below the table are 'Apply' and 'Cancel' buttons. A 'Sensor Configuration' link is highlighted with a red dot and a callout box that says 'Link to return to the Sensors page.'

### To set humidity sensor thresholds:

1. Provide the threshold hysteresis between event state and recovery(%RH). Range is 0-20%RH; default is 2%RH.
2. Set the low/high alarm and low/high warning threshold values for the humidity sensor(%RH). Range is min 0%RH, max100%RH.
3. Click **Apply**.

## Configuring Temperature Sensors Thresholds

Click the temperature sensor thresholds link at the bottom of the Sensors page to display the configuration page:

The screenshot shows the configuration page for Humidity Sensor Thresholds. The interface includes a left-hand navigation menu with categories like Overview, Monitoring, Control, Configuration, System, and Shutdown. The main content area is titled 'Humidity Sensor Thresholds' and contains a 'Configure humidity sensor hysteresis' section with a 'Hysteresis' input field set to 2. Below this is a table for 'Configure humidity sensor thresholds' with columns for ID, Humidity Sensor Name, Low Alarm, Low Warning, High Warning, and High Alarm. The table lists four sensors (A1, A2, B1, B2) with their respective threshold values. At the bottom of the table are 'Apply' and 'Cancel' buttons, and a 'Sensor Configuration' link. An orange callout box points to the 'Sensor Configuration' link with the text 'Link to return to the Sensors page.'

ID	Humidity Sensor Name	Low Alarm	Low Warning	High Warning	High Alarm
A1	Humid_Sensor_A1	5 % RH	10 % RH	90 % RH	95 % RH
A2	Humid_Sensor_A2	5 % RH	10 % RH	90 % RH	95 % RH
B1	Humid_Sensor_B1	5 % RH	10 % RH	90 % RH	95 % RH
B2	Humid_Sensor_B2	5 % RH	10 % RH	90 % RH	95 % RH
		All % RH	All % RH	All % RH	All % RH

### To set temperature sensor thresholds:

1. Provide the threshold hysteresis between event state and recovery temperature. Range is 0-30° Celsius, or 0-54° Fahrenheit; default is 1° Celsius or 2° Fahrenheit.
2. Set the low/high alarm and low/high warning threshold values for the temperature sensor(°). Range is minimum -40° to maximum 123° Celsius, or minimum -40° to maximum 253° Fahrenheit.
3. Click **Apply**.



## Configuring Environmental Monitoring (EMCU) Thresholds

If an EMCU is connected to the PRO2 unit, the Sensors page will also allow configuration of water, contact closure and analog-to-digital (ADC) voltage sensors – to provide sensor name and SNMP/Email notifications.

In addition, for ADC voltage sensors only, high/low warning/alarm thresholds can be set. Water and contact closure sensors can have either Normal or Alarm status – there are no other states or value ranges.

**Sensors**

Configure global sensor settings

Temperature Scale:

Configure temperature sensors

ID	Sensor Name	SNMP Trap Notifications	Email Notifications
A1	<input type="text" value="Temp_Sensor_A1"/>	<input checked="" type="checkbox"/>	<input checked="" type="checkbox"/>
A2	<input type="text" value="Temp_Sensor_A2"/>	<input checked="" type="checkbox"/>	<input checked="" type="checkbox"/>
B1	<input type="text" value="Temp_Sensor_B1"/>	<input checked="" type="checkbox"/>	<input checked="" type="checkbox"/>
B2	<input type="text" value="Temp_Sensor_B2"/>	<input checked="" type="checkbox"/>	<input checked="" type="checkbox"/>
E1	<input type="text" value="Temp_Sensor_E1"/>	<input checked="" type="checkbox"/>	<input checked="" type="checkbox"/>
E2	<input type="text" value="Temp_Sensor_E2"/>	<input checked="" type="checkbox"/>	<input checked="" type="checkbox"/>

Configure relative humidity sensors

ID	Sensor Name	SNMP Trap Notifications	Email Notifications
A1	<input type="text" value="Humid_Sensor_A1"/>	<input checked="" type="checkbox"/>	<input checked="" type="checkbox"/>
A2	<input type="text" value="Humid_Sensor_A2"/>	<input checked="" type="checkbox"/>	<input checked="" type="checkbox"/>
B1	<input type="text" value="Humid_Sensor_B1"/>	<input checked="" type="checkbox"/>	<input checked="" type="checkbox"/>
B2	<input type="text" value="Humid_Sensor_B2"/>	<input checked="" type="checkbox"/>	<input checked="" type="checkbox"/>
E1	<input type="text" value="Humid_Sensor_E1"/>	<input checked="" type="checkbox"/>	<input checked="" type="checkbox"/>
E2	<input type="text" value="Humid_Sensor_E2"/>	<input checked="" type="checkbox"/>	<input checked="" type="checkbox"/>

Configure water sensors

ID	Sensor Name	SNMP Trap Notifications	Email Notifications
E1	<input type="text" value="Water_Sensor_E1"/>	<input checked="" type="checkbox"/>	<input checked="" type="checkbox"/>

Configure contact sensors

ID	Sensor Name	SNMP Trap Notifications	Email Notifications
E1	<input type="text" value="Contact_Sensor_E1"/>	<input checked="" type="checkbox"/>	<input checked="" type="checkbox"/>
E2	<input type="text" value="Contact_Sensor_E2"/>	<input checked="" type="checkbox"/>	<input checked="" type="checkbox"/>
E3	<input type="text" value="Contact_Sensor_E3"/>	<input checked="" type="checkbox"/>	<input checked="" type="checkbox"/>
E4	<input type="text" value="Contact_Sensor_E4"/>	<input checked="" type="checkbox"/>	<input checked="" type="checkbox"/>

Configure analog to digital voltage sensors

ID	Sensor Name	SNMP Trap Notifications	Email Notifications
E1	<input type="text" value="ADC_Sensor_E1"/>	<input type="checkbox"/>	<input type="checkbox"/>

[ADC Sensor Thresholds](#)  
[Humidity Sensor Thresholds](#)  
[Temperature Sensor Thresholds](#)

### To set ADC voltage sensor thresholds:

1. Click the ADC sensor thresholds link at the bottom of the Sensors page to display the configuration page:

**ADC Sensor Thresholds**

Configure ADC sensor hysteresis

Hysteresis:

Configure ADC sensor thresholds

ID	ADC Sensor Name	Low Alarm	Low Warning	High Warning	High Alarm
E1	ADC_Sensor_E1	<input type="text" value="0"/>	<input type="text" value="0"/>	<input type="text" value="255"/>	<input type="text" value="255"/>

[Sensor Configuration](#)

2. Provide the threshold hysteresis between event state and recovery. Range is 0-20; default is 1.
3. Set the low/high alarm and low/high warning threshold values for the ADC sensor. Range is 0-255; default is 0.
4. Click **Apply**.

## System > Shutdown

The **Shutdown** page configures the remote shutdown options for outlets (for Switched PRO2 products only).

The PRO2 supports the ability to initiate an orderly shutdown of a specific outlet or outlet group after performing a user-specified shutdown operation.

The shutdown also protects open application files prior to a server being powered down. Shutdown signaling is initiated over the existing TCP/IP network and requires the use of a remote shutdown agent.

The screenshot shows the configuration page for the Shutdown feature on a PRO2 Sentry Switched PDU. The page title is "Shutdown" and it lists controlled outlets in the selected unit. The selected unit is "dD4\$~`!@#%&^&\*()\_+\_=j". Below this, there is a table to configure unit shutdown settings for 20 outlets (AA1 to AA20). Each outlet row includes a checkbox for enabling the shutdown, a field for Shutdown/Delay (90 sec), a checkbox for enabling the script, a field for Script/Delay (1 min), and a field for Hostname/IP.

ID	Outlet Name	Shutdown/Delay	Script/Delay	Hostname/IP
AA1	Master_Outlet_1	<input type="checkbox"/> 90 sec	<input type="checkbox"/> 1 min	
AA2	Master_Outlet_2	<input type="checkbox"/> 90 sec	<input type="checkbox"/> 1 min	
AA3	Master_Outlet_3	<input type="checkbox"/> 90 sec	<input type="checkbox"/> 1 min	
AA4	Master_Outlet_4	<input type="checkbox"/> 90 sec	<input type="checkbox"/> 1 min	
AA5	Master_Outlet_5	<input type="checkbox"/> 90 sec	<input type="checkbox"/> 1 min	
AA6	Master_Outlet_6	<input type="checkbox"/> 90 sec	<input type="checkbox"/> 1 min	
AA7	Master_Outlet_7	<input type="checkbox"/> 90 sec	<input type="checkbox"/> 1 min	
AA8	Master_Outlet_8	<input type="checkbox"/> 90 sec	<input type="checkbox"/> 1 min	
AA9	Master_Outlet_9	<input type="checkbox"/> 90 sec	<input type="checkbox"/> 1 min	
AA10	Master_Outlet_10	<input type="checkbox"/> 90 sec	<input type="checkbox"/> 1 min	
AA11	Master_Outlet_11	<input type="checkbox"/> 90 sec	<input type="checkbox"/> 1 min	
AA12	Master_Outlet_12	<input type="checkbox"/> 90 sec	<input type="checkbox"/> 1 min	
AA13	Master_Outlet_13	<input type="checkbox"/> 90 sec	<input type="checkbox"/> 1 min	
AA14	Master_Outlet_14	<input type="checkbox"/> 90 sec	<input type="checkbox"/> 1 min	
AA15	Master_Outlet_15	<input type="checkbox"/> 90 sec	<input type="checkbox"/> 1 min	
AA16	Master_Outlet_16	<input type="checkbox"/> 90 sec	<input type="checkbox"/> 1 min	
AA17	Master_Outlet_17	<input type="checkbox"/> 90 sec	<input type="checkbox"/> 1 min	
AA18	Master_Outlet_18	<input type="checkbox"/> 90 sec	<input type="checkbox"/> 1 min	
AA19	Master_Outlet_19	<input type="checkbox"/> 90 sec	<input type="checkbox"/> 1 min	
AA20	Master_Outlet_20	<input type="checkbox"/> 90 sec	<input type="checkbox"/> 1 min	

### To configure shutdown settings:

1. For an individual outlet in the list, type the desired Shutdown/Delay for the outlet (in seconds), or accept the 90-second default, and check the corresponding checkbox. The shutdown/delay sets the time to wait after the shutdown notification before changing outlet state; range is 1-900 seconds; default is 90 seconds.
2. For an individual outlet in the list, type the desired Script/Delay for the outlet (in minutes) to set the time to wait after the script has executed to change outlet state, and check the corresponding checkbox; range is 1-15 minutes; default is 1 minute.
3. Provide the hostname/IP address for the target server.
4. Click **Apply**.

### About the Remote Shutdown Feature

When the Remote Shutdown Agent is installed on the server and the Shutdown feature is configured on the PRO2, the following **shutdown process** occurs:

1. The Off or Reboot command is received by the PRO2.
2. Shutdown signal is sent to the Remote Shutdown Agent on the target server.
3. The Remote Shutdown Agent initiates a systematic shutdown of the target server for all actions that remove power from the outlet (such as the Off and Reboot commands), and allows the execution of user-defined scripts to perform custom activities, like safely shutting down open databases.
4. The PRO2 removes power from the outlet.

## Shutdown and Smart Load Shedding

The Smart Load Shedding feature allows the load shedding of outlet loads, both on CDU and PRO2 products, based on UPS condition (on-battery), temperature level, and input current load.

The Shutdown feature for Switched products is also supported by the extended license-key feature Smart Load Shedding. A systematic shutdown is initiated by Smart Load Shedding events such as high temperature, high infeed load, and UPS “on battery” conditions.

## Supported Operating Systems for Shutdown

Remote Shutdown Agents are available for the following operating systems:

- Windows: 2000, 2003, XP.
- Linux: Red Hat 7.3, 8.0; Red Hat Enterprise 2.1 ES (update 5); 3.0 ES (update 4); Novell SUSE Linux Enterprise Server.
- Unix: HP-UX 11.0, 11i v1, 11i v2; IBM AIX 4.3, 5.3; Sun Solaris 8, 9, 10.
- Novell Netware: 6

## Installing the Shutdown Agent



**Note:** For all operating systems shown below, if the IP address of the PRO2 is left blank in the last step of these installation instructions, any PRO2 can send a shutdown signal to the server.

### *Windows*

1. Browse to the location of the Remote Shutdown Agent installation files.
2. Run **setup.exe** by double-clicking the icon.
3. Reply to the standard installation prompts.
4. For additional security, when prompted, enter the IP address of the PRO2 that will be sending the shutdown signal.

### *Linux*

1. Browse to the location of the Remote Shutdown Agent installation files.
2. Run **SetupRA**.
3. For additional security, when prompted enter the IP address of the PRO2 that will be sending the shutdown signal.

### *Unix*

1. Browse to the location of the Remote Shutdown Agent installation files.
2. Run **Install**.
3. For additional security, when prompted enter the IP address of the PRO2 that will be sending the shutdown signal.

### *Novell Netware*

1. Browse to the location of the Remote Shutdown Agent installation files.
2. From the NetWare system console, load the configuration module (**pmconfig.nlm**) using the default path.
3. For additional security, when prompted enter the IP address of the PRO2 that will be sending the shutdown signal.

## System > Trending

The **Trending** page generates a report (and related source data sets) of measured system trends over a 7-day period, with the range of each day from midnight to midnight. The trend data in the report is for viewing and analysis only – no actions occur automatically based on the data.

Each time a measurement is taken on the PRO2 unit, the measurement is aggregated into the metrics for the current day. The aggregation process includes updating the maximum and minimum values for each measurement, as well as updating the average with the new measurement.

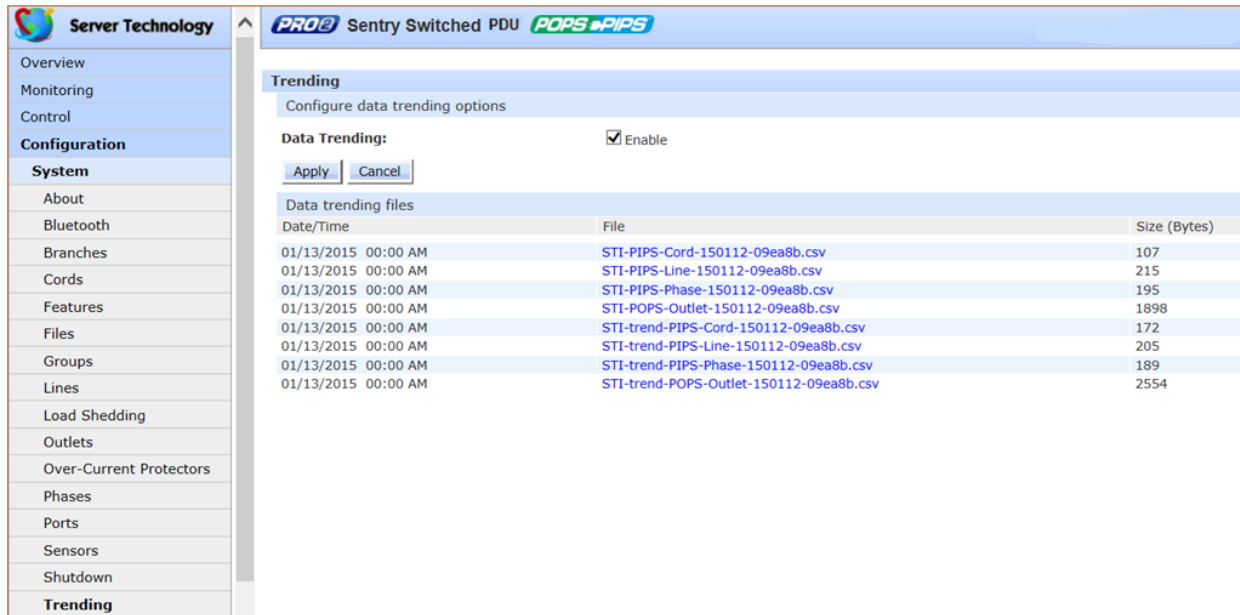

Date/Time	File	Size (Bytes)
01/13/2015 00:00 AM	STI-PIPS-Cord-150112-09ea8b.csv	107
01/13/2015 00:00 AM	STI-PIPS-Line-150112-09ea8b.csv	215
01/13/2015 00:00 AM	STI-PIPS-Phase-150112-09ea8b.csv	195
01/13/2015 00:00 AM	STI-POPS-Outlet-150112-09ea8b.csv	1898
01/13/2015 00:00 AM	STI-trend-PIPS-Cord-150112-09ea8b.csv	172
01/13/2015 00:00 AM	STI-trend-PIPS-Line-150112-09ea8b.csv	205
01/13/2015 00:00 AM	STI-trend-PIPS-Phase-150112-09ea8b.csv	189
01/13/2015 00:00 AM	STI-trend-POPS-Outlet-150112-09ea8b.csv	2554

### To activate the trending feature:

1. Check the Enable checkbox.
2. Click **Apply**. The page automatically displays generated .csv trend report files, along with related source data sets, for viewing.

### System Requirements for Trending

- Firmware, version 8.0x or later.
- SNTP must be enabled (to keep track of when the daily measurements are taken).

## What Data Does Trending Measure?

### ■ REQUIREMENTS

For the Trending feature to occur and display (for viewing only) on the PRO2 GUI at **System > Trending**, SNTP must be enabled to keep track of when daily measurements are taken.

Certain measurements for PIPS and POPS (if POPS is present) are tracked by the Trending feature:

For all PIPS cords/phases/lines, the following measurements are tracked:

- Phase voltage
- Line current
- Cord watts
- Cord power factor

### ■ WHAT IS MEASURED?

For all POPS outlets, the following measurements are tracked:

- Current
- Watts
- Power factor

### ■ ADDITIONAL TRACKED METRICS

For all of the above PIPS/POPS measurements, the following metrics will also be tracked:

- Minimum measurement
- Maximum measurement
- “In-use average” measurement



**Note:** PIPS is a standard feature on all PRO2 units, but if the unit does not have POPS, then only the PIPS measurements will be tracked.

### ■ REQUIREMENTS

For the Trending feature to occur and display (for viewing only) on the PRO2 GUI at **System > Trending**, SNTP must be enabled to keep track of when daily measurements are taken.

Certain measurements for PIPS and POPS (if POPS is present) are tracked by the Trending feature:

For all PIPS cords/phases/lines, the following measurements are tracked:

- Phase voltage
- Line current
- Cord watts
- Cord power factor

## How Does the Trending Feature Work?

Each time a measurement is taken on the PRO2 unit, the measurement is aggregated into the metrics for the current day. The aggregation process includes updating the maximum and minimum values for each measurement, as well as updating the average with the new measurement.

Any measurements that have no current or are turned off will not be aggregated; this means the “in-use average” metric will be the reported metric.

Each day’s worth of data will be stored in flash memory with a timestamp for use in generating a trending report. Only data from the last 8 days is kept. The report is not stored in flash memory but is regenerated into RAM after a system reboot.

If there is no data set that is 8 days old (1 week ago) for comparison, the trending data will indicate 100% increase for all reported trending data.

If the system is updated or units are moved/changed/removed/added, all trending will be restarted. In the event of communication loss to link units, trending data will not be lost.

### About the Trending Report

- The report (and the data sets the report is generated from) are all stored separately.
- The report is created at midnight.
- The report contains the percent change of the average, maximum, and minimum measurements of the day compared to the daily metrics from the same day on the previous week (7 days ago).
- The data set contains the actual values that the report was generated from: the average, maximum, and minimum for the day

	A	B	C	D	E
1	Line ID	Amps min	Amps ma	Amps avg	6-Jan-2015
2	AA1	0	0	0	
3	AA2	0.25	1.64	1.021	
4	AA3	0.68	2.13	2.118	
5	AA4	0.25	2.29	1.216	
6	BA1	0.25	0.29	0.256	
7	BA2	0.27	0.29	0.278	
8	BA3	0.29	0.35	0.309	
9	BA4	-	-	-	

Example of Line source data set

	A	B	C	D	E	F
1	Line ID	Name	% chg Am	% chg Am	% chg Am	11-Jan-15
2	AA1	AA:L1	-	-	-	
3	AA2	AA:L2	-	-	-	
4	AA3	AA:L3	-	-	-	
5	AA4	AA:N	-	-	-	

Example of Line trend report

### Accessing and Distributing the Trend Report and Data Sets

The report (and the individual data sets the report is generated from) are available at all times at **Configuration > System > Trending** as comma delimited text files (HTTP, HTTPS, FTP, SFTP interfaces).

The file format name of the report and data sets is "STI-trend-(object)-yymmdd-macaddress.csv".

Optionally, after the report is generated, the report (and the most recent 24-hour period of data in a data set file) can be sent as an attachment to the primary and secondary "send to" email addresses.

## System > Units

The **Units** page sets a descriptive system name for each PRO2 unit, configures asset management identification, determines outlet sequence, and sets the display orientation of the mounted unit. The page also sets sets SNMP Trap and Email notifications for unit events.

The Purge and Restore link on the Units page displays another page to allow the clearing of current values in non-volatile (NV) memory from individual units, and the resetting of those values back to factory defaults.

The screenshot shows the configuration page for a PRO2 Sentry Switched PDU. The left sidebar contains a navigation menu with categories like Overview, Monitoring, Control, Configuration, System, About, Bluetooth, Branches, Cords, Features, Files, Groups, Lines, Outlets, Over-Current Protectors, Phases, Ports, Sensors, Shutdown, Units, UPS, Network, Access, and Tools. The main content area is titled 'Units' and contains two tables.

Unit Identification					
ID	Unit Type	Model Number	Product Serial Number	Asset Tag	Identify
A	Master	STV-6503K	STVU0000118	testtag1	<input type="checkbox"/>
B	Link	SEV-4503K	(not set)	AGHWERAFS	<input type="checkbox"/>

Configure unit settings					
ID	Unit Name	Outlet Sequence	Display Orientation	SNMP Trap Notifications	Email Notifications
A	Master	Normal	Auto	<input checked="" type="checkbox"/>	<input checked="" type="checkbox"/>
B	Link1	Normal	Auto	<input checked="" type="checkbox"/>	<input checked="" type="checkbox"/>

Buttons: Apply, Cancel, All None, All None, Unit Purge & Restore

### To configure the PRO2 unit:

1. (Optional) Provide an asset tag identification for listed master and/or link units and check the Identity checkbox.
2. In the Unit Name field, provide a descriptive text name for the unit, from 0-32 characters. The ID is a system-assigned internal name and cannot be changed.
3. For Switched products, the PRO2 allows configuration of the power-on sequence of the outlets with the following available options. From the Outlet Sequence drop-down menu, select an option:
  - Normal: (Default) Powers on outlets in ascending numeric order by outlet number, for example, from outlet 1-8.
  - Reversed: Powers on outlets in descending order by outlet number; for example, from outlet 8-1. The Reversed option is useful when the PRO2 is mounted with inverted orientation and the last outlet (in this example, outlet 8) is in the first position.
4. From the Display Orientation drop-down menu, select an option:
  - Normal: Sets the LED display to be right-side up (for vertical mounting of the unit), and outlet sequencing to be 1 to n.
  - Inverted: Sets the LED display to be upside down.
  - Auto (Default): Sets automatic LED display orientation using internal orientation sensor.
5. For each unit listed on the page, check (or uncheck) the SNMP Trap Notifications and/or Email Notifications checkboxes to enable (or disable) unit event notification for a specific unit.



## Set Unit Defaults – System Settings Unchanged

The Set Unit Defaults – System Settings Unchanged function resets the following subset of configuration items (in the NIC of the master PRO2 unit) to factory default values:

- Power items: Cords, lines, phases, over-current protectors (OCPs), branches, outlets.
- Sensor items: Temperature, humidity, water\*, contact closure\*, ADC\*  
(\* = EMCU unit only)
- User-configuration items related to the above power/sensor areas: Object names, thresholds, hysteresis, nominal values, limits, system location, notification enables, shutdown settings, Bluetooth® options, Smart Load Shedding options, outlet options, and more.



**Note:** User-configured system-level items **will not be reset** to factory defaults: Users, groups, network, LDAP, TACACS, features, UPS devices, login banner, etc.

### To purge/restore NV memory:

1. From the **Units** page, click the Unit Purge & Restore link to display the following page:

ID	Unit Name	Unit Type	Model Number	Product SN	Asset Tag	Status
A	Master	Master	STV-6503K	STVU0000118	testtag1	Normal
B	Link1	Link	SEV-4503K	(not set)	AGHWERAFS	Normal

2. From the drop-down menu, select a unit as listed on the page by its internal system-assigned number in the ID field, such as unit A, unit B, etc., or select all units.

- No Action
- Unit A
- Unit B
- Unit C
- Unit D
- Unit E
- Unit F
- All Units

3. Click **Purge**. A message displays to confirm the purge action. The units selected will have NV memory purged and restored to factory default values.

## System > UPS

The **UPS** page manages UPS devices connected to a PRO2 unit. A connected UPS device can be added to or deleted from the system. Several device options are available for configuration, including a configurable UPS name, and assignment of PRO2 lines to be powered by the UPS.

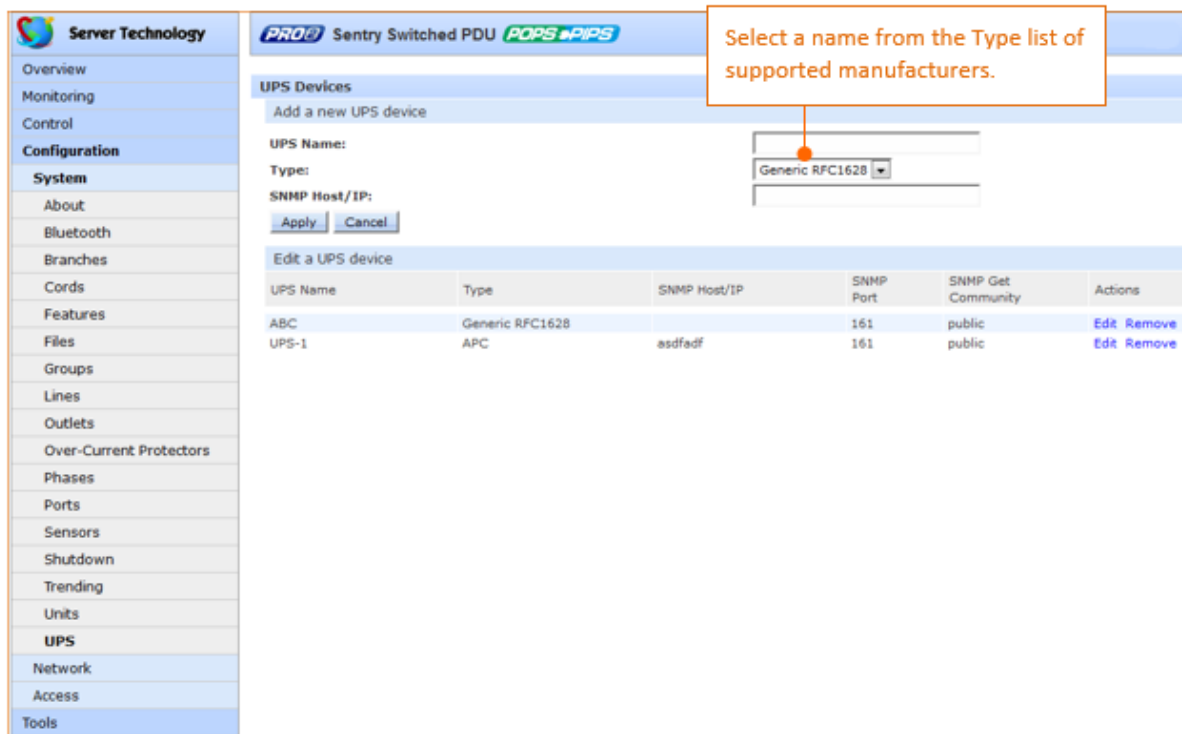

Select a name from the Type list of supported manufacturers.

UPS Name	Type	SNMP Host/IP	SNMP Port	SNMP Get Community	Actions
ABC	Generic RFC1628		161	public	Edit Remove
UPS-1	APC	asdfadf	161	public	Edit Remove

### To add a new UPS:

1. Type a UPS name.
2. Select the UPS manufacturer from the Type drop-down menu.
3. Type an SNMP hostname/IP address in the field provided.
4. Click **Apply**. The new UPS displays in the list of UPS devices. The list displays in alphabetic order by UPS name.

### Configuring a UPS:

For a UPS listed on the page, click the Edit link to display the edit window:

#### UPS Device Edit

Edit settings for this UPS device

**UPS Name:** ABC

**Type:** Generic RFC1628

**SNMP Host/IP:**

**SNMP Port:** 161 (default 161)

**SNMP Get Community String:** public

**SNMP Status Object ID:** .1.3.6.1.2.1.33.1.4.1.0

**SNMP On Utility Value:** 3

**SNMP On Battery Value:** 5

#### Configure lines powered by this UPS device

ID	Line Name	Powered by this UPS
AA1	AA:L	<input type="checkbox"/>
BA1	BA:L	<input type="checkbox"/>

[All](#)  
[None](#)

[UPS Configuration](#)

### To configure a UPS:

1. From the Type drop-down list, select the UPS manufacturer.
2. Type the desired values for the SNMP-related fields or accept the defaults as shown on the page.
3. Check the corresponding checkboxes for the line(s) that are powered by the UPS. To select all lines for the UPS, click All (or click None to deselect all lines).
4. Click **Apply**.

### To remove a UPS:

1. For a UPS listed, click the Remove link. You will be prompted to confirm the removal of the UPS.

## Network (Setting Up Network Protocols)

The **Network** section of the Web interface provides network setup options for the protocols supported by PRO2: DHCP/IP, Email/SMTP, FTP, HTTP/HTTPS, LDAP, RADIUS, SNMP, SNTP, Syslog, TACACS+, and Telnet/SSH.



**Note:** The **Network** section only allows the administrator to set up network protocol parameters. To configure how the PRO2 user uses the network and system, see the **Access** section.

### Network > DHCP/IP

The **DHCP/IP** page allows configuration of the acquisition method for the protocol stack, viewing of current network communication settings, determining static IPv4/IPv6 address formats, and enabling DHCP options.

DHCP/IP	
Network configuration	
Network:	IPv4 Only
State:	Static IPv4
Link:	Up
Speed:	100 Mbps
Duplex:	Full
Negotiation:	Auto
Ethernet MAC Address:	00-0A-9C-60-01-E9
Autocfg IPv6 Address:	FE80::20A:9CFF:FE60:1E9/64
IPv4 Address:	10.1.2.57
IPv4 Subnet Mask:	255.255.0.0
IPv4 Gateway:	10.1.1.1
Primary DNS:	10.1.5.133
Secondary DNS:	10.1.5.134
Configure static IPv4/IPv6 settings	
IPv6 Address:	:: /64
IPv6 Gateway:	::
IPv4 Address:	10.1.2.57
IPv4 Subnet Mask:	255.255.0.0
IPv4 Gateway:	10.1.1.1
Primary DNS:	10.1.5.133
Secondary DNS:	10.1.5.134
Configure DHCP settings	
DHCP:	<input type="checkbox"/> Enable
FQDN:	<input checked="" type="checkbox"/> Enable sentry-6001e9
Boot Delay:	<input type="checkbox"/> Enable
Static Address Fallback:	<input type="checkbox"/> Enable
<input type="button" value="Apply"/> <input type="button" value="Cancel"/>	

#### To configure DHCP/IP:

1. Network: Determines the acquisition method used for the protocol stack: “Disabled”, “Dual IPv6/IPv4”, or “IPv4 only”. For maximum backward compatibility, accept the default network mode “IPv4 only”.
2. View the fields in the next section of the page as a quick reference for current network parameters:

For more information about how PRO2 handles the network with IPv6/IPv4 options, see [Network-Enabled Modes](#) in this user guide.

### **To configure static IPv4/IPv6:**

1. IPv4/IPv6 Address/Gateway: Provide the address for these fields in either IPv4 or IPv6 format.
2. IPv4 Subnet Mask: If IPv4 is used, supply the IP address for the subnet mask in IPv4 format.
3. Primary/Secondary DNS: Provide the IP address for the primary and secondary DNS hostnames.

### **To configure DHCP settings:**

1. DHCP: Check (or uncheck) Enable to enable/disable DHCP support.
2. FQDN: Provide the fully-qualified domain name (FQDN) name and check Enable.
3. Boot Delay: Check (or uncheck) the Enable checkbox to enable/disable the Boot Delay option with the following results:
  - Enable: The Boot Delay option gives the PRO2 approximately 100-seconds to establish a connection through a DHCP server. The interval allows various network component activities to occur as the PRO2 powers up (such as obtaining SNTP time stamps for logging).
  - Disable: (Default) The Boot Delay option forces the PRO2 to boot after approximately 5-seconds regardless of the DHCP acquisition state. This speeds up a boot when a DHCP server is connected to one of the outlets in the PRO2. In this configuration, SNMP traps, SNTP, and other protocols will not be available until a DHCP address has been resolved.



#### **Notes:**

- The Boot Delay option executes only when DHCP is enabled.
  - The firmware can detect network link integrity and will wait for network connection. This means that if the network is not currently connected, the enabled Boot Delay option will be ignored.
4. Static Address Fallback: Check (or uncheck) the Enable checkbox to enable/disable the Static Address Fallback option with the following results:
    - Enable: The Static Address Fallback option informs the PRO2 to automatically fall back to a static address if a DHCP server does not respond after 90-seconds.
    - Disable: (Default) The Static Address Fallback option generates DHCP server requests until the PRO2 obtains a dynamic address.



#### **Notes:**

- The Static Address Fallback option executes only when DHCP is enabled.
- If the DHCP server boot time is excessive, you may need to disable the DHCP Static Address Fallback option.
- The DHCP Static Address Fallback option does not apply when WLAN is enabled.

## **Network Defaults**

The PRO2 has the following network defaults to allow unit configuration through Telnet or Web:

IP Address: 192.168.1.254

Subnet Mask: 255.255.255.0

Gateway: 192.168.1.1

The initial local PC network connection must be configured as follows:

IP Address: 192.168.1.x (where x is 2-253).

Subnet Mask: 255.255.255.0



**Note:** The PRO2 must be restarted after network configuration changes.

## Network > Email/SMTP

The **Email/SMTP** page allows configuration of the Email/SMTP protocol and email options.

**Server Technology** | PRO2 Sentry Switched PDU | POPS to PIPS

### Email/SMTP

Configure email / simple mail transport protocol options

SMTP Host:

SMTP Port: 25 (default 25)

SMTP Authentication: None with SMTP Username

SMTP Username:

SMTP Password:   Change

'From' Address:

Primary 'Send To' Address:

Secondary 'Send To' Address:

Subject ID: Use Default [Sentry\_600029]

### Configure email notification options

Email Notifications:  Enable

EVENT Messages:  Enable

AUTH Messages:  Enable

POWER Messages:  Enable

CONFIG Messages:  Enable

Trend Files:  Enable

To test email: After configuring the Email/SMTP page, you can send a test email to the target (primary and secondary) email destinations by clicking the Test button.



### Authentication Notes:

- SMTP authentication allows the mail client in the PRO2 to log into the mail server during the process of sending an email. The mail server may require this login to relay mail to another mail server.
- The supported SMTP authentication types are: None (default, no SMTP authentication); Digest-MD5; CRAM-MD5, Login, Plain, and Any. SMTP authentication occurs with a configured username/password, or the address in the 'From' Address field with 'From' Address selected can be used in place of the username.

### To configure SMTP protocol options:

1. Type the hostname/IP address in the SMTP Host field (either IPv4 or IPv6 format).
2. Provide the port number or accept the default as shown.
3. From the drop-down menu, select the authentication method, and from the "with" menu, select username or 'from' as described directly above in the notes.
4. Type the desired Email/SMTP username; spaces are not allowed.
5. Type the password for the username. The password sets the SMTP authentication with the username. Acceptable passwords are 1-32 alphanumeric characters, case-sensitive, and spaces are not allowed. To change the password, type over it, and check the Change box.
6. Provide the 'From' email address.
7. Provide the Primary/Secondary 'Send To' email address. If the primary 'send to' address fails, the system then attempts to send the email to the secondary 'send to' address.
8. From the Subject ID drop-down menu, select the "Sentry\_nnnnnn" default option (where "nnnnnn" is the last 3 octets of the MAC address), or select the "Location" option to specify the email subject line.
9. Click **Apply**.

***To configure Email notification options:***

1. Check the Enable checkbox to enable Email notifications to be sent.
2. For the event notifications shown, check the corresponding Enable checkbox to enable an alert message via email. The events are:
  - EVENT: System activity event
  - AUTH: Authentication event
  - POWER: Power event
  - CONFIG: System configuration event
  - Trend Files: Sends the trend files via Email
3. Click **Apply**.



## Network > FTP

The **FTP** configuration page allows configuring the settings required for the FTP client to perform FTP firmware uploads and automatic system uploads/downloads.

The screenshot shows the configuration page for the PRO2 Sentry Switched PDU. The left sidebar contains a navigation menu with categories: Server Technology, Overview, Monitoring, Control, Configuration, System, Network, DHCP/IP, Email/SMTP, FTP, HTTP/HTTPS, LDAP, RADIUS, SNMP, SNTP, Syslog, TACACS+, Telnet/SSH, Access, and Tools. The main content area is titled 'FTP' and is divided into two sections: 'Configure FTP client options' and 'Configure FTP server options'. The 'Configure FTP client options' section includes fields for Host (10.1.2.100), Username (taxe), Password (with a Change button), Directory (/firmware/8.0f/), and Filename (pro-v80f.bin). It also has an 'Automatic Updates' section with an 'Enable' checkbox, a 'Scheduled Day' dropdown (Monday), and a 'Scheduled Hour' dropdown (12 AM), along with a 'Test' button. The 'Configure FTP server options' section has an 'FTP Server' checkbox (checked) and 'Apply' and 'Cancel' buttons.

### To configure FTP client options:

1. Type the hostname/IP addresses in the Host field (IPv4 or IPv6 format).
2. Type the FTP username in the Username field, 1-32 characters, spaces are allowed.
3. Provide a password for the FTP username. To change the password, check the Change box and type the new password.
4. Type the file path to be uploaded to the Directory field.
5. Type the filename to be uploaded in the Filename field.
6. The PRO2 is capable of scheduling automatic firmware updates. When enabled and configured, the PRO2 regularly checks the FTP server for a new firmware image and uploads the image. To enable Automatic Updates, check the Enable checkbox.
7. From the Scheduled Day and Scheduled Hour drop-down menus, select the desired day/hour for the automatic update.
8. The FTP upload configuration validates that the unit is able to contact and log into the specified FTP server, download the firmware file, and verify that the firmware file is valid for the unit. To initiate the test, click the **Test** button.

### To configure FTP server options:

1. In the FTP Server area at the bottom of the page, check the **Enable** checkbox.



#### Notes:

- The FTP server must be enabled for configuration upload or download.
- Secure File Transport Protocol (SFTP) is also supported for encrypted SSH transport over the network.

## Network > HTTP/HTTPS

The **HTTP/HTTPS** page configures server options for HTTP, HTTPS, and SSL, including user-defined certificates. The page also determines settings for the Sentry Power Manager (SPM) enterprise software product.

The screenshot shows the configuration page for a Sentry Switched PDU. The interface is divided into a left-hand navigation menu and a main configuration area. The navigation menu includes sections like Overview, Monitoring, Control, Configuration, System, Network, and Tools. The main area is titled 'HTTP/HTTPS' and contains three sections: 'Configure HTTP server options', 'Configure HTTPS/SSL server & user certificate options', and 'Configure Sentry Power Manager secure access options (HTTPS Required)'. The first section has 'HTTP Server' (checked) and 'HTTP Port' (80). The second section has 'HTTPS Server' (checked), 'HTTPS Port' (443), 'User Certificate' (unchecked), 'Passphrase' (empty), 'Stored Files' (None), and 'Installed Certificate' (Factory). The third section has 'SPM Access' (checked) and a 'Reset' button. 'Apply' and 'Cancel' buttons are at the bottom left.

### To configure HTTP and HTTPS/SSL:

1. Server: Check (or uncheck) the Enable checkboxes to enable/disable support for the HTTP and/or HTTPS/SSL server options.
2. Port: Type a port number or accept the default HTTP/HTTPS/SSL port numbers as displayed. The HTTP default port number is 80; the SSL default port number is 443.



### Notes:

- SSL-encrypted (HTTPS) must be used for secure website connections.
- The number of concurrent HTTP/S sessions supported depends on the web browser in use.

### To configure HTTPS/SSL only:

1. User Certificate: Check (or uncheck) the Enable checkbox to enable/disable support for custom user certificates.
2. Passphrase: Provide a passphrase (0-63 characters) for the new user certificate. To change the passphrase, type a new passphrase and check the Change checkbox
3. Stored Files: This section displays a message (described in the following table) to confirm the upload status of the user certificate and its related public key.

### Custom User Certificate Messages

Message	Description and Valid Values/Range
Cert & Key	Both the user certificate and its key were uploaded successfully.
Cert	User certificate was uploaded without a key.
No Cert	User certificate was not uploaded.
Factory Encrypted	User certificate was encrypted and uploaded at product assembly.
None	Neither the user certificate nor its key were uploaded.

4. Installed Certificate: Shows the type of certificate that was installed – Factory, User, Company.

### To configure Sentry Power Manager (SPM) options:

The Sentry Power Manager (SPM) is Server Technology's enterprise management software product for the data center. The configuration options provided allow you to enable/disable SPM and reset the SPM password to its default.

1. SPM Secure Access: Check (or uncheck) the Enable checkbox to enable/disable SPM Secure Access. If your operation does not currently use SPM, you can disable this option. However, when the option is disabled, the PRO2 will not be able to use the secure network features or advanced remote configuration provided by SPM.
2. SPM Password: Each PRO2 unit has a unique default SPM password that communicates between SPM and the PRO2. For added security, when SPM discovers a PRO2 in the network, SPM changes the default password to a different (and unique) password and continues to manage or alter passwords as required for on-going system security. To reset the SPM password, click the **Reset** button.
3. Click **Apply**.



#### Notes:

- The SPM options apply only if you are currently using SPM.
- Both HTTP and HTTPS/SSL must be enabled or the SPM Secure Access will not be allowed. When allowed, the SPM Secure Access checkbox is enabled by default.
- Do not reset the SPM Password if SPM communication has already been established.

## Network > LDAP

The LDAP page determines the protocol settings required to enable LDAP support.



**Note:** The **Network > LDAP** page is for LDAP network protocol management only. To manage LDAP user groups, see the **Access > LDAP Groups** page.

The Change Access Configuration link takes you to the Access page to determine user access method for LDAP.

### To configure LDAP:

1. LDAP: Enabled or Disabled displays on the page to show current LDAP status.
2. Primary/Secondary Host: Provide the hostname/IP address of the Directory Services server.
3. Port: Set the port number for the LDAP server, 1-65535 (Default is 389).
4. Bind Type: Sets the bind method for the LDAP server. The PRO2 supports three standard LDAP bind methods:
  - Simple: Uses unencrypted delivery of username-password over the network to the LDAP server for authentication, showing user credentials in plain text.
  - TLS/SSL: (LDAP over TLS/SSL) Uses a trusted authority certificate to provide encryption of LDAP authentication.
  - MD5: Provides strong protection using 1-way hash encoding that does not transmit the username-password over the network.
5. From the Bind Type drop-down menu, select Simple, TLS/SSL, or MD5. If TLS/SSL is selected, MD5 binding is disabled.
6. Search Bind: Provide the base distinguished name (DN) for the search bind and the Search Bind Password for the base DN. To change the password, type the new password, and check the Change checkbox.
7. User Search: Provide the distinguished name (DN) for the user search.
8. Filter: The User Search Filter sets the filter used for the username search at login.
9. Group Membership Attribute: Sets the user class distinguished name (DN) or names of groups a user is a member of.
10. Group Search: Click to enable the setting of the bind to search groups for the username (in addition to searching the usernames for its list of group memberships).

11. Base DN: Indicates where the LDAP group search will start.
12. User Membership Attribute: The user membership option allows the searching of directory entries of groups for a user membership attribute to find the groups for which the user is a member. Provide a comma-delimited string of up to two attribute names whose values in the search results are the users that are members of the group. Maximum numbers of characters is 61.
13. Click **Apply**.

## Network > RADIUS

The **RADIUS** page provides configuration options for RADIUS server support.

The screenshot shows the 'RADIUS' configuration page. On the left is a navigation menu with 'RADIUS' selected. The main content area is titled 'RADIUS' and contains a 'Configure RADIUS options' section. Below this, there are fields for 'Primary Server' and 'Secondary Server', each with sub-fields for 'Shared Secret', 'Port', 'Timeout', and 'Retries'. There are 'Apply' and 'Cancel' buttons at the bottom. A callout box on the right points to a 'Change Access Configuration' link, with text explaining that this link leads to the 'Access' page to determine user access methods.

### To configure the RADIUS server:

1. RADIUS: Enabled or Disabled displays on the page to show current RADIUS status.
2. Sets the Primary/Secondary RADIUS server hostname/IP address used for RADIUS authentication requests. Maximum 63 characters.
3. Shared Secret: The RADIUS authentication key used for authentication requests. Up to 48 uppercase and lowercase alphanumeric and other typed characters (ASCII 33 to 126 decimal) are allowed; spaces are allowed; control characters are not allowed. To change the secret, edit the Shared Secret field (characters are not displayed) and check the Change checkbox.
 

**Note:** The secret that was set for the primary server will not be cleared when setting the secret for the secondary server, and vice versa.
4. Port Number: Used by the RADIUS server for incoming RADIUS authentication requests. Provide a custom port number or accept the default port numbers as displayed. Valid range is 1-65535; default as shown on the screen is 1812.
5. Timeout: Specifies the time interval (in seconds) to wait for a reply from the RADIUS server before resending an authentication request. Provide the custom timeout value or accept the default timeout as displayed. Valid range is 1-30 seconds; default is 5 seconds.
6. Retries: Indicates the number of times an authentication request is sent to the RADIUS server. The PRO2 attempts authentication on the primary server until the number of retries is reached, then attempts authentication with the secondary server. If the PRO2 does not receive a response from the retry attempts, the authentication request will be rejected. Provide a number in the Retries field. Valid range is 0-10; default is 2.
7. Click **Apply**.

## About RADIUS Vendor-Specific Attributes (VSA)

In addition to the protocol-required attributes, the RADIUS authentication process can be extended by using private vendor-specific attributes (VSA). This extension allows Server Technology to create its own proprietary attributes to support features and services using the PRO2 in the RADIUS authentication process.

Server Technology has defined and formatted RADIUS vendor-specific attributes (VSA) in the dictionary.sti file, which is available from Server Technology. The PRO2 is configured to recognize and use the configuration values in the file as specified by the network administrator, indicating to the RADIUS server that the defined attributes are based on Server Technology's unique enterprise vendor code.

Using the format of the dictionary.sti file (located on the Server Technology FTP site at ftp.servertech.com), the PRO2 RADIUS implementation supports the following vendor-specific attributes:

### Vendor-Specific Attribute (VSA) Descriptions

Attribute	Description
STI-Access-Level	Indicates user access level for the Switched PRO2; values are 1-6 as follows; a valid access level is required or access to the unit is denied.  Valid Access Levels: 1 = Admin 2 = Power User 3 = User 4 = Reboot Only 5 = On Only 6 = View Only
STI-Env-Mon	Determines user access rights to environmental monitoring; values are Yes or No. For the STI-Access-Level value other than 1 (Admn), if STI-Env-Mon is not included for a user, default is no.
STI-Outlets	Specifies user access rights to outlets; values are space-delimited strings of absolute IDs, names, or the special keyword "ALL". String values are case-sensitive and limited to 253 characters. This attribute can be repeated to append strings that declare additional access rights. For STI-Access Level values other than 1 (Admn) and 2 (Power User), if STI-Outlets is not included for a user, the default is no outlet.
STI-Groups	Specifies user access rights to groups of outlets; values are space-delimited strings of absolute IDs, names, or the special keyword "ALL". String values are case-sensitive and limited to 253 characters. This attribute can be repeated to append strings that declare additional access rights. For STI-Access Level values other than 1 (Admn) and 2 (Power User), if STI-Groups is not included for a user, the default is no group.
STI-Ports	Specifies user access rights to ports; values are space-delimited strings of absolute IDs, names, or the special keyword "ALL". String values are case-sensitive and limited to 253 characters. This attribute can be repeated to append strings that declare additional access rights. For STI-Access Level values other than 1 (Admn) and 2 (Power User), if STI-Ports is not included for a user, the default is no ports.



**Note:** User access levels must be configured using the **dictionary.sti** file. If the administrator does not use the **dictionary.sti** file to configure a user, the user will not have access rights to the PRO2.

### Examples:

Administrator with full access and configuration rights:

```
sti-admin Auth-Type := Local, User-Password == "admin"  
STI-Access-Level = Admin
```

Power user with environmental monitoring allowed and full outlet/group/port access rights:

```
sti-power Auth-Type := Local, User-Password == "power"  
STI-Access-Level = Power-User,  
STI-Env-Mon = Yes
```

User with environmental monitoring not allowed and specific outlet/group/port access rights:

```
sti-user Auth-Type := Local, User-Password == "user"  
STI-Access-Level = User,  
STI-Env-Mon = No,  
STI-Outlets = ".A1 .A2 Rtr1 Rtr2 Srvr1 Srvr2",  
STI-Outlets += ".A3 .A4 Rtr3 Rtr4 Srvr3 Srvr4",  
STI-Groups = "Routers Servers",  
STI-Ports = "Console"
```

View-Only user with environmental monitoring allowed and all outlet and group access rights:

```
sti-view Auth-Type := Local, User-Password == "view"  
STI-Access-Level = View-Only,  
STI-Env-Mon = Yes,  
STI-Outlets = "ALL",  
STI-Outlets = "ALL"
```

## Network > SNMP

The **SNMP** page provides the protocol and agent configuration options for SNMP support.

The screenshot shows the 'SNMP' configuration page. On the left is a navigation menu with 'SNMP' selected. The main content area is titled 'Configure SNMP agent options'. It is divided into three sections:

- SNMPv2 Agent:** Includes a checked 'Enable' checkbox, 'GET Community (RO):' (public), and 'SET Community (RW):' (private).
- SNMPv3 Agent:** Includes an unchecked 'Enable' checkbox, 'Engine ID:' (800006B60200), 'Read/Write Username:' (empty), 'Read/Write User Auth Method:' (None), 'Read/Write User Auth Password:' (empty), 'Read/Write User Privacy Password:' (empty), 'Read-Only Username:' (empty), 'Read-Only User Auth Method:' (None), 'Read-Only User Auth Password:' (empty), and 'Read-Only User Privacy Password:' (empty). Each password field has a 'Change' link.
- SNMP Trap:** Includes 'Format:' (v1), 'v2 Community:' (trap), 'v3 Username:' (empty), 'Destination 1:' (10.1.7.149), 'Destination 2:' (empty), 'IP Restrictions:' (None), 'Error Repeat Time:' (60 seconds), 'System Name:' (Sentry\_6001e9), 'System Location:' (empty), and 'System Contact:' (empty). There are 'Apply' and 'Cancel' buttons at the bottom.

### About SNMP Versions

- The firmware supports SNMP v1, v2c, and v3.
- SNMP version 3 supports authentication and encryption on a per user basis. Authentication types are None and MD5. Encryption types are None and DES. If you use authentication, you must use encryption.
- Two SNMPv3 users are supported: one user with read-write (RW) access, and one user with read-Only (RO) access. Both users have the same configuration parameters, and you can configure each user independently.
- SNMPv2c and SNMPv3 can be enabled or disabled independently. You can have SNMPv2 and/or SNMPv3, or none.

## Concurrent Sessions

SNMP is session-less and supports multiple simultaneous manager operations.

### To configure the SNMP v2 agent:

1. Check (or uncheck) the Enable checkbox to enable/disable SNMP v2 support.
2. GET community (RO): Community strings for GET commands.
3. SET community (RW): Community strings for SET commands.
4. Click **Apply**.



**Note:** The default for SNMP support is **Enabled**. When Server Technology products are shipped, the default SNMP configuration for the GET community string is set to “**public**” and the SET community string is left **blank**.

### To configure the SNMP v3 agent:

1. Check (or uncheck) the Enable checkbox to enable/disable SNMP v3 support.
2. Engine ID: Unique system-assigned ID for each PRO2 unit that cannot be user-edited.
3. For the Read/Write or Read-Only Username: Provide a username between 1-31 characters.
4. For the Read/Write or Read-Only User Auth Method: From drop-down menu, select the MD5 Authentication Only or MD5 Authentication & DES Privacy option, or accept the default None.
5. For the Read/Write or Read-Only User Auth Password: Provide a value between 1-39 characters. To clear the password, check Change checkbox.
6. For the Read/Write or Read-Only User Privacy Password: Provide a value between 1-31 characters. To clear the password, check Change checkbox.
7. Click **Apply**.

### To configure the SNMP trap:

1. Format: Configures the SNMP trap format version. The trap format can be SNMP v1, v2c, or v3. The default is v1, regardless of the versions that are enabled for the agent.
2. v2 Community: SNMP trap community for PRO2.
3. v3 Username: (Optional). Provide a trap username to display on SNMP v3 activity logs to identify user actions. The trap username can be 1-31 alphanumeric characters; spaces are allowed; the name is case sensitive.
4. For Destination 1 and Destination 2: Provide first and second trap destinations as a hostname or IP address.
5. IP Restrictions: From the drop-down menu, select None (default) or Trap Destinations Only. If Trap Destinations Only is selected, SNMP Manager GET and SET requests are allowed only from the IP address of the defined trap destinations.
6. Error Repeat Time: Sets the SNMP trap repeat time for an object in an event condition. Provide a time value from 1 to 65535 (in seconds).
7. System Name/Location/Contact: (Optional) Type the system name, location, and contact string from 1-63 characters.
8. Click **Apply**.



## Network > SNTP

The **SNTP** page provides configuration options for the SNTP server, time zone, and Daylight Saving Time (DST) automatic clock adjustment.

### About Daylight Saving Time (DST)

Support for DST is enabled by default. When enabled, the date and time are automatically adjusted forward one hour between the starting and ending dates/times, which can be configured.



**Note:** If DST is enabled, all system time displays will be shown with the current DST start/end date/time settings.

The default time zone is set for the United States until at least 2015. The time zone format is **mo.w.d/h:m:s**, described as follows:

DST Parameter	Description	Value
mo	Both from January to December	1-12
w	Week number	1-4, or last week
d	Day of the week from Sunday to Saturday	0-6
h	Hour	0-23
m	Minute	0-59
s	Second	0-59

### To configure the SNTP server:

1. Local Date/Time: Displayed to show the local and current DST settings. To increment the settings (based on updates to the options for DST Start/DST End and day/time), click the Update link.
2. The Primary/Secondary Host fields contact the SNTP server. The fields are populated with the the external NTP pool time zones “2.servertech.pool.ntp.org” and “1.servertech.pool.ntp.org” as the default for new PRO2 units that have not yet been time set. To edit the host fields, type the desired hostname/IP address in the Primary/Secondary Host fields.
3. From the Local GMT Offset drop-down menu, select the extended local offset hours and provide minutes. The GMT offset supports all standard international time zones from -12:59 to +14:59. The GMT offset can be set in minutes to accommodate partial-hour time zones.
4. To enable Daylight Saving Time (DST), check the Enable box.
5. From the DST Start/End drop-down menus, set the start/end date/time options.
6. Click **Apply**.

## Network > Syslog

The **Syslog** page supports RFC3164 and RFC5424 compliance and the configuration for standard message logging to enable offline storage and viewing of firmware log messages and system events.

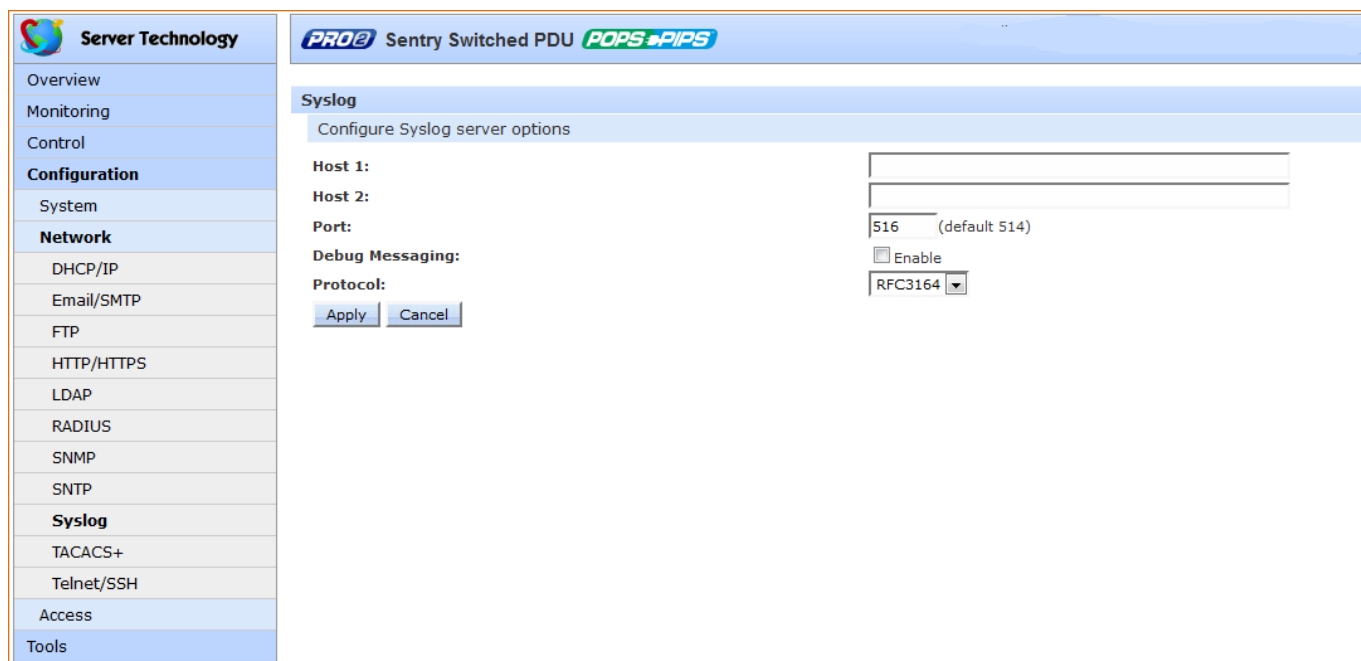

The screenshot shows the 'Syslog' configuration page in the PRO2 web interface. The page title is 'PRO2 Sentry Switched PDU POPS+PIPS'. The main heading is 'Syslog' with a sub-heading 'Configure Syslog server options'. The configuration fields are: 'Host 1:' and 'Host 2:' (both empty text boxes), 'Port:' (text box containing '516' with '(default 514)' next to it), 'Debug Messaging:' (checkbox labeled 'Enable' which is unchecked), and 'Protocol:' (dropdown menu showing 'RFC3164'). At the bottom are 'Apply' and 'Cancel' buttons. On the left is a navigation menu with categories: Overview, Monitoring, Control, Configuration, System, Network, and Syslog. Under 'Network' are DHCP/IP, Email/SMTP, FTP, HTTP/HTTPS, LDAP, RADIUS, SNMP, and SNTP. Under 'Syslog' are TACACS+, Telnet/SSH, Access, and Tools.

### To configure the Syslog server:

1. Host 1/Host2: Set the Syslog server address by typing the hostname/IP address in the Host1 and/or Host2 field(s). Both IPv4 and IPv6 IP address formats are allowed.
2. Port: When Syslog support is enabled, the Syslog server responds to requests on the default Syslog port number 514 as displayed on the page. If necessary, edit the port number.
3. Debug Messaging: To enable debug messaging in the Syslog debug log, check the Enable box.
4. Protocol: From the drop-down menu, select the RFC protocol that determines behavior of the Syslog server and message transmission
5. Click **Apply**.

## Network > TACACS+

The **TACACS+** page allows configuration for TACACS+ server options, encryption key, and user privilege levels.

The Change Access Configuration link takes you to the Access page to determine user access method for TACACS+.

Click link to configure privilege levels.

### To configure TACACS+ server options:

1. Type the hostname/IP address in the Primary/Secondary Host fields (IPv4 or IPv6 format).
2. Type the new port number or accept the default 49 as shown in the screen example. The PRO2 uses the port number to send TACACS+ requests.
3. Click **Apply**.

### About the TACACS+ Encryption Key

The encryption key is used to encrypt all data packets between the PRO2 and the TACACS+ server:

- The key must match the key configured on the TACACS+ server.
- The key can be up to 60 alphanumeric characters and is case sensitive.
- For security, characters in the key are not displayed.
- If you provide “0” for the key, the result may be that the key is not applied, as “0” may not be supported by the TACACS+ server. It is recommended for product environment and security not to enter “0” for the key.
- The Encryption Key Status field on the screen displays “(set)” or “(not set)” to indicate current status of the key.

### To configure the encryption key:

1. Type the New Encryption Key in the field provided.
2. In the Verify New Encryption Key field, retype the key.
3. Click **Apply**.

## Assigning User Access Rights to TACACS+ Privilege Levels

1. At the bottom of the TACACS+ screen, click the TACACS+ Privilege Levels link to display the following edit page which shows the current user access level for each TACACS+ privilege level.

**TACACS+ Privilege Levels**  
Edit or assign access rights to a TACACS+ privilege level

TACACS+ Privilege Level	Access Level	System Monitor	Access Rights	Action
0	User	No	Access	Edit
1	User	No	Access	Edit
2	User	No	Access	Edit
3	User	No	Access	Edit
4	User	No	Access	Edit
5	User	No	Access	Edit
6		No	Access	Edit
7		No	Access	Edit
8		No	Access	Edit
9		No	Access	Edit
10		No	Access	Edit
11	User	No	Access	Edit
12	User	No	Access	Edit
13	User	No	Access	Edit
14	User	No	Access	Edit
15	Admin	Yes	ALL	Edit

[TACACS+ Network Settings](#) Click link to configure the TACACS+ network.

2. For a privilege level shown in the above list, click **Access** to display the Privilege Level Access page:

**TACACS+ Privilege Level Access**  
TACACS+ Privilege Level being assigned access rights

0

TACACS+ Privilege Level can access the following selected monitors

Monitor	Grant Access
System	<input type="checkbox"/>

TACACS+ Privilege Level can access the following selected remote ports

ID	Port Name	Grant Access
COM1	Console	<input type="checkbox"/>
COM2	Aux	<input type="checkbox"/>
		All
		None

TACACS+ Privilege Level can access the following selected groups

Group Name	Grant Access
GROUP11	<input type="checkbox"/>
Outlet_Group_1	<input type="checkbox"/>
	All
	None

TACACS+ Privilege Level can access the following selected outlets

ID	Outlet Name	Grant Access
AA1	Master_Outlet_1	<input type="checkbox"/>
AA2	Master_Outlet_2	<input type="checkbox"/>
AA3	Master_Outlet_3	<input type="checkbox"/>

3. Check individual boxes to grant user access (or uncheck boxes to deny access) to specific system resources: monitors, remote ports, outlet groups, and individual outlets. To grant (or deny) access to all (or none) of the resources in a group, click All or None.
4. Click **Apply**.

## Configuring TACACS+ Privilege Levels

The PRO2 supports 16 different TACACS+ privilege levels. The administrative-level user can configure 15 privilege levels. One level is reserved by default for access to all PRO2 resources by the administrative-level user. Six defined user privilege levels are available: Admin, Power User, User, On-Only User, Reboot-Only User, and View-Only User.

1. At the bottom of the TACACS+ screen, click the TACACS+ Privilege Levels link to display the following edit page which shows the current user access level for each TACACS+ privilege level.

TACACS+ Privilege Level	Access Level	System Monitor	Access Rights	Action
0	User	No	Access	Edit
1	User	No	Access	Edit
2	User	No	Access	Edit
3	User	No	Access	Edit
4	User	No	Access	Edit
5	User	No	Access	Edit
6	lo	lo	Access	Edit
7	lo	lo	Access	Edit
8	lo	lo	Access	Edit
9	lo	lo	Access	Edit
10	lo	lo	Access	Edit
11	User	No	Access	Edit
12	User	No	Access	Edit
13	User	No	Access	Edit
14	User	No	Access	Edit
15	Admin	Yes	ALL	Edit

2. For a privilege level shown in the above list, click **Edit** to display the TACACS+ Privilege Level Edit page:

From the Access Level list, select a user access level for the displayed TACACS+ privilege level.

3. From the Access Level drop-down menu, select a user access level for the displayed TACACS+ privilege level, as described:

User Access Level (highest to lowest)	Description
Administrator	Administrative user; full access for all configuration, all outlet power control actions (On, Off, Reboot), status, and serial/pass-thru ports.
Power User	Full access for all outlet power control actions (On, Off, Reboot), status, and serial/pass-thru ports. <b>Note: The Power User does not have access to user management.</b>
User	Partial access for outlet power control actions (On, Off, Reboot), status, and pass-thru of assigned outlets, outlet groups, and serial/pass-thru ports.
Reboot-Only User	Partial access for outlet power control actions (Reboot), status, and pass-thru of assigned outlets, outlet groups, and serial/pass-thru ports.
On-Only User	Partial access for outlet power control actions (On), status, and pass-thru of assigned outlets, outlet groups, and serial/pass-thru ports.
View-Only User	Partial access for status and pass-thru of assigned outlets, outlet groups, and serial/pass-thru ports.

4. Click **Apply**.

## Network > Telnet/SSH

The **Telnet/SSH** page provides server, port, and authentication options for support of Telnet and SSH.

**Server Technology**

Overview  
Monitoring  
Control  
**Configuration**  
System  
**Network**  
DHCP/IP  
Email/SMTP  
FTP  
HTTP/HTTPS  
LDAP  
RADIUS  
SNMP  
SNTP  
Syslog  
TACACS+  
**Telnet/SSH**  
Access  
Tools

**PRO2** Sentry Switched PDU **POPS+PIPS**

### Telnet/SSH

Configure Telnet server options

Server:  Enable  
Port: 23 (default 23)

Configure SSH server options

Server:  Enable  
Port: 22 (default 22)  
Authentication Method: Keyboard Interactive Or Password

Apply Cancel

### To configure the Telnet server and/or SSH server:

1. Server: Check (or uncheck) the Enable checkbox to enable/disable support for Telnet and/or SSH.
2. Port: Type a custom port number or accept the default port number 23 (for Telnet) or the default port number 22 (for SSH), as displayed on the page.
3. For SSH only – Authentication Method: The SSH server supports the following authentication methods.
  - Keyboard Interactive: The SSH server controls an information field followed by one or more prompts requesting credential information from the SSH client. The client gathers credential information typed by the user and sends it back to the server. The Keyboard Interactive method is controlled by the SSH server.
  - Password: The SSH client gathers username/password credentials and makes the authentication request to the SSH server with the credentials. The Password method is controlled by the SSH client.
  - Keyboard Interactive or Password: (Default). Allows either method.
4. From the drop-down menu, select one of the security methods described above, or accept the default, as displayed
5. Click **Apply**.

### Telnet/SSH Concurrent Sessions

- For Telnet: 4 concurrent sessions allowed; also allowed are 4 Telnet **and** 4 SSH sessions simultaneously.
- For SSH: 4 concurrent sessions allowed; also allowed are 4 SSH **and** 4 Telnet sessions simultaneously.

## The WLAN Solution

A high performance Wireless Local Area Network (WLAN) solution is available, for firmware 8.0c or later, and using Wi-Fi capable PRO2 products.

The wireless network solution is designed according to IEEE standards 802.11b/g/n 2.4 GHz for implementing network connectivity using Wi-Fi.

When enabled, the **Configuration > Network** page displays the WLAN option, as follows, where Wi-Fi settings are configured:

**Server Technology** | **PRO2** Sentry Switched CDU **POPS+PIPS**

### WLAN

Configure wireless local area network options

**WLAN:**  Enable

**SSID:**

**Key:**

**Security:**

**Optional BSSID:**

#### Available wireless access points

Channel	SSID	BSSID	Security	Networks	Signal
1	STI	06:27:22:CF:AB:A0	WPA1WPA2/TKIPAES	11b/g/n	65%
1	Eng	5C:FC:66:68:9B:90	WPA2PSK/AES	11b/g/n	29%
1	STI-Guest	0A:27:22:CF:AB:A0	WPA1PSKWPA2PSK/TKIPAES	11b/g/n	50%
6	STI	DC:9F:DB:1C:FD:C7	WPA1WPA2/TKIPAES	11b/g/n	44%
6	STI	24:A4:3C:04:15:FE	WPA1WPA2/TKIPAES	11b/g/n	81%
11	STI	24:A4:3C:04:18:B4	WPA1WPA2/TKIPAES	11b/g/n	15%
11	STI	00:27:22:FA:13:98	WPA1WPA2/TKIPAES	11b/g/n	34%
11	Eng	A8:9D:21:9B:7B:30	WPA2PSK/AES	11b/g/n	20%
11	STI-Guest	2A:A4:3C:04:18:B4	WPA1PSKWPA2PSK/TKIPAES	11b/g/n	15%
11	STI-Guest	06:27:22:FA:13:98	WPA1PSKWPA2PSK/TKIPAES	11b/g/n	34%
11	FW-WIFI-DEV	EC:1A:59:49:70:E0	WPA2PSK/AES	11b/g/n	100%
11	Ellipsis Jetpack 2BB5	80:D2:1D:50:2B:B5	WPA2PSK/AES	11b/g/n	20%

Scan Complete

Copyright © 2002-2015 All Rights Reserved. [www.servertech.com](http://www.servertech.com) 1.775.284.2000

For more information about setting network configurations for the wireless network, a description of the PRO2 products designated for this solution, and considerations for access point (AP) installation, see Server Technology's website, [www.servertech.com](http://www.servertech.com), for Technical Note, 303-9999-37, "Wi-Fi Solution with 802.11b/g/n Support for Wi-Fi Capable PRO2 Products."



## Access (Managing Users)

The **Access** section of the Web interface determines how a PRO2 user works with the network and system by configuring the options related to a user: authentication, privilege levels, user access to the unit, and additional functions for individual local users and user groups.



**Note:** The **Access** section only allows the administrator to determine how the PRO2 user uses the network and system. To set up network protocol parameters, see the **Network** section.

### Access > General

The **General** page allows configuration of local and remote access settings.

#### To configure general system access:

1. Access Method: From the drop-down menu, select an option to enable one of several authentication methods to control user access to the PRO2. Only one method can be enabled at a time: Local Only (default), LDAP Only, LDAP Then Local, RADIUS Only, RADIUS Then Local, TACACS+ Only, TACACS+ Then Local.
2. Button Configuration Reset: Check (or uncheck) the Enable checkbox to enable (or disable) physical access to the **Reset** button on the PRO2 hardware.

The PRO2 is designed with a reset button on the hardware unit that can be used when a forgotten firmware password prevents logging into the unit. The reset button sets all configuration values back to factory default settings, allowing the administrator to retrieve the admn/admn default administrator login.

To access the button on the unit, you need a non-conductive metallic tool that fits inside the recess. If you press and hold the **Reset** button on the unit for more than 15 seconds, the reset action will terminate.



**Note:** This method of physical access to the unit will not work if the reset button has already been disabled by the administrator through the firmware GUI at **Configuration > Access > General > Button Configuration Reset** (shown in the screen example above) or through the firmware CLI with the **set access button [enabled/disabled]** command. For security, the administrator can choose to disable the button through firmware to inhibit a user from causing a reset on the unit.

3. Local Administrator Account: Removes the last local administrator account when remote authentication (LDAP, TACACS+, or RADIUS) is in use. Only a remotely-authenticated administrator can remove the last local administrator account.

Accept the “Required” option (default), or select “Optional”. Selecting “Optional” disables the restriction to remove the last local administrator, and also enables the Configuration Reset Button.

In turn, disabling the Configuration Reset Button automatically changes the Local Administrator Account to “Required”. When this change occurs, if no local administrator accounts are present, the Configuration Reset Button will be set back to enabled.

Both the Local Administrator Account drop-down and the Configuration Reset Button turn the other field on if one of them has an Optional setting or is unchecked (disabled).



**Note:** For PRO2 or PRO1 units only. If LDAP, TACACS+, or RADIUS is unreachable, or if LDAP, TACACS+, or RADIUS parameters have changed, you may not be able to log into the PRO2 or PRO1 unit.

3. Strong Passwords: From the drop-down menu, select Optional or Required. The PRO2 supports strong passwords for enhanced system security. From the Strong Passwords drop-down menu, select Optional or Required. If Required, the strong password requirement is applied against all new passwords with the following rules:
  - Minimum of 8 characters long, at least one uppercase letter, at least one lowercase letter, one number, and one special character.
  - When a strong password is changed, a minimum of four characters positions must be changed to define the new password.
4. Custom CLI Prompt: Type a custom text string for the Command Line Interface (CLI) prompt, or leave blank for the default prompt “Switched CDU:”
5. CLI Session Timeout: Enter a timeout period (in minutes). The valid timeout range is 1 to 1440 minutes (24 hours); the default is 5 minutes.
6. Web Session Timeout: Enter a timeout period (in minutes). The valid timeout range is 1 to 1440 minutes (24 hours); the default is 5 minutes.
7. Web Log Entries Per Page: Set the number of entries displayed on the system log, from 10 to 250.
8. Default Log Order: From the drop-down menu, specify the order of the event entries on the system log – oldest events or newest events displayed first in the log.
9. StartUp Stick: Check (or uncheck) to enable (or disable) StartUp Stick®. StartUp Stick is a separate Server Technology tool for streamlining the mass configuration of PDU operating parameters.
10. Click **Apply**.

## Login Banner:

Clicking the Login Banner link displays a blank banner edit window. The following example shows a custom message:

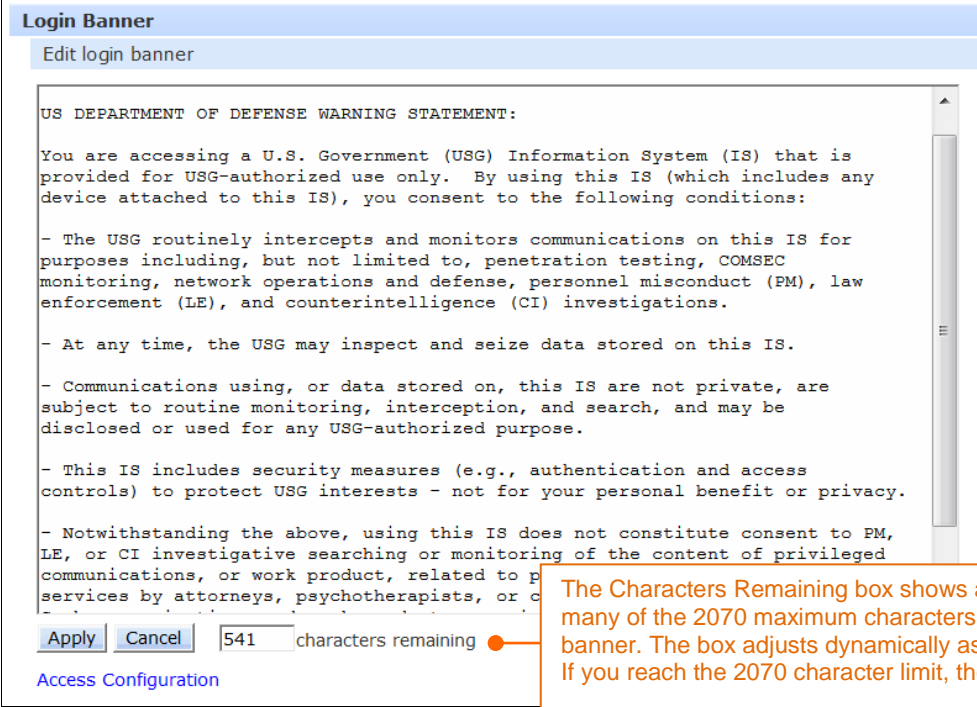

The screenshot shows a web interface titled "Login Banner" with a sub-header "Edit login banner". Below this is a text area containing a warning statement from the US Department of Defense. At the bottom of the text area are "Apply" and "Cancel" buttons, and a character count box showing "541 characters remaining". A callout box points to the character count box with the following text:

The Characters Remaining box shows as you type (in real time) how many of the 2070 maximum characters are still available to complete the banner. The box adjusts dynamically as you type or delete characters. If you reach the 2070 character limit, the box will display "0".

Type the banner text and click **Apply**. To clear the typed entry and start over, click **Cancel**.



### Notes:

- The login banner can be up to 2070 characters long and will be displayed prior to the login prompt.
- If the login banner is left blank, the user will be taken directly to the login prompt.
- For an SSH connection, the banner length is truncated to 1500 bytes in SSH packets to avoid failure of the SSH connection when configured with a long text banner.

## Access > Local Users

The **Local Users** page allows the administrator to manage options for local users, including creating new users, changing user passwords, setting user access level, and granting user access to various resources of the PRO2.

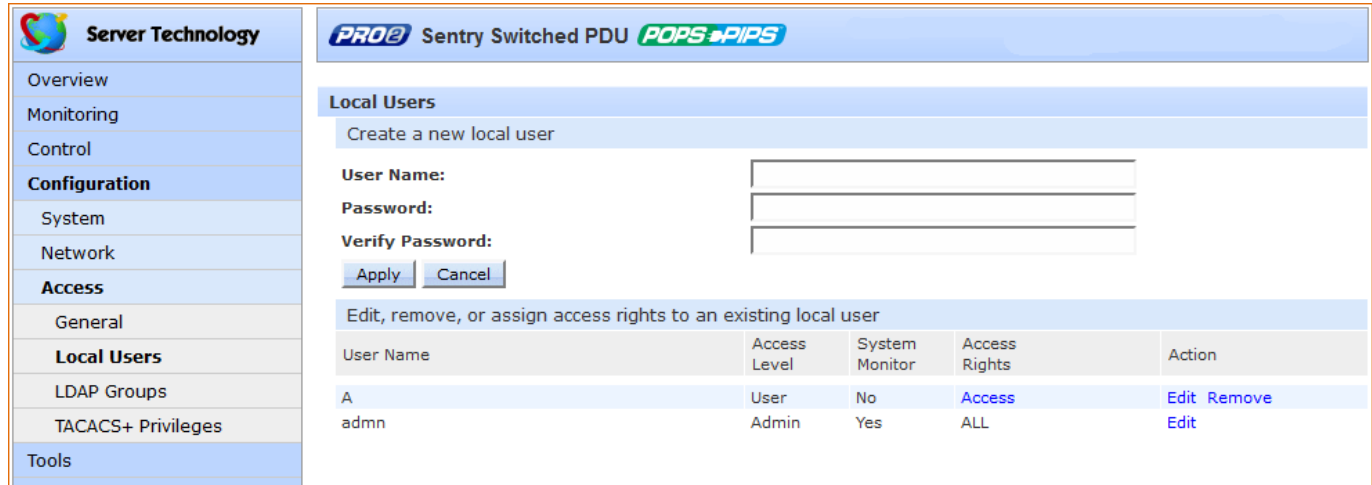

**Local Users**

Create a new local user

User Name:

Password:

Verify Password:

Edit, remove, or assign access rights to an existing local user

User Name	Access Level	System Monitor	Access Rights	Action
A	User	No	<a href="#">Access</a>	<a href="#">Edit</a> <a href="#">Remove</a>
adm	Admin	Yes	ALL	<a href="#">Edit</a>

### To create a new local user:

1. In the User Name field, type a 1-32 character user name; no spaces; user names are not case-sensitive.
2. Type the user's password; type a 1-32 character password; ASCII 33 to 126 decimal characters are allowed; passwords are case-sensitive.
3. Verify the password.
4. Click **Apply**.

### To grant access rights to a user:

1. For the user name displayed in the list, click the Access link. The Local User Access page displays to allow granting access rights to selected PRO2 monitors, remote ports, outlet groups, and individual outlets by checking corresponding checkboxes. To deny access to an individual resource, uncheck the related checkbox. To grant (or deny) access to all resources in a displayed group, click All or None.
2. Click **Apply**.

### To set a user's access level:

1. For the user name displayed in the list, click the Edit link. The Local User Edit page displays.
2. From the Access Level drop-down menu, select the desired user access level as described in the table below.
3. Click **Apply**.

User Access Level (highest to lowest)	Description
Administrator	Administrative user; Full access for all configuration, all outlet power control actions (On, Off, Reboot), status, and serial/pass-thru ports.
Power User	Full access for all outlet power control actions (On, Off, Reboot), status, and serial/pass-thru ports. <b>Note: The Power User does not have access to user management.</b>
User	Partial access for outlet power control actions (On, Off, Reboot), status, and pass-thru of assigned outlets, outlet groups, and serial/pass-thru ports.
Reboot-Only User	Partial access for outlet power control actions (Reboot), status, and pass-thru of assigned outlets, outlet groups, and serial/pass-thru ports.
On-Only User	Partial access for outlet power control actions (On), status, and pass-thru of assigned outlets, outlet groups, and serial/pass-thru ports.
View-Only User	Partial access for status and pass-thru of assigned outlets, outlet groups, and serial/pass-thru ports.
System Monitor	Access to all "stat" commands on the Command Line Interface (CLI).

### To change a user's password:

1. For the user name displayed in the list, click the Edit link. The Local User Edit page displays.
2. Type the user's new password; type a 1-32 character password; ASCII 33 to 126 decimal characters are allowed; passwords are case-sensitive.
3. Verify the new password.
4. Click **Apply**.

### To delete a local user:

1. For the user name displayed in the list, click the Remove link. You will be prompted with a confirmation for the delete action.
2. Click **OK** or **Cancel**.



**Note:** The **adm** default administrator account cannot be removed unless administrative access has already been granted to another administrative account.

## Access > LDAP Groups

The **LDAP Groups** page allows the administrator to manage options for LDAP user groups, including creating new LDAP groups, establishing the LDAP group access level, and granting LDAP group access to various resources of the PRO2.

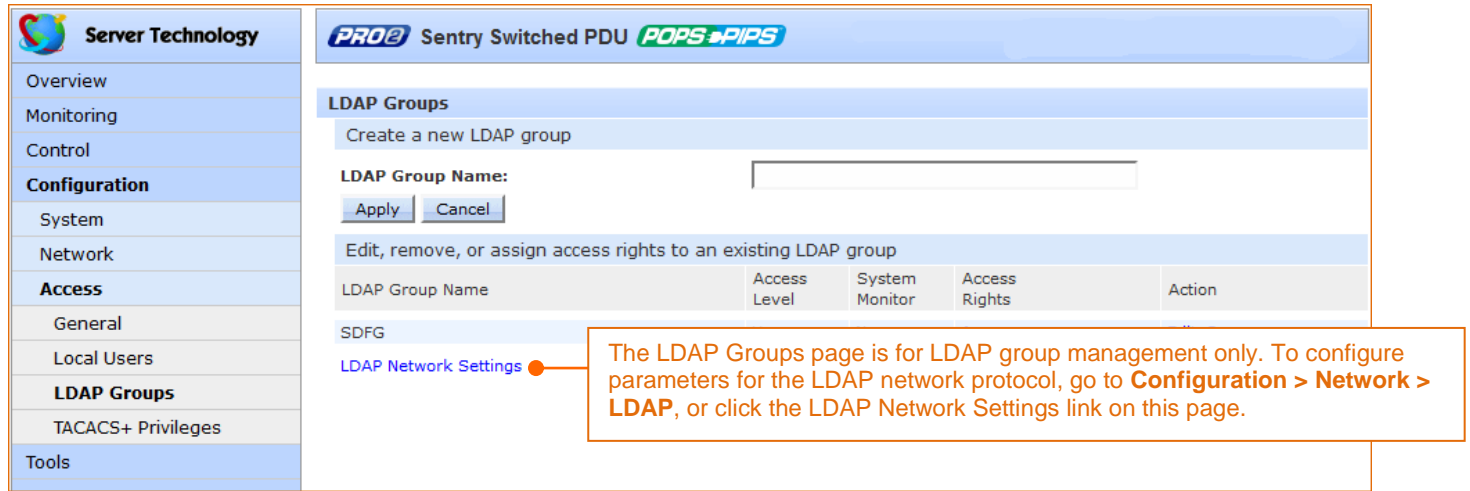

LDAP Group Name	Access Level	System Monitor	Access Rights	Action
SDFG				

### To create a new LDAP group:

1. In the LDAP Group Name field, type a 1-32 character LDAP group name; no spaces; LDAP group names are not case-sensitive.
2. Click **Apply**.

### To grant access rights to an LDAP group:

1. For the LDAP group name displayed in the list, click the Access link. The LDAP Group Access page displays to allow granting access rights to selected PRO2 monitors, remote ports, outlet groups, and individual outlets by checking corresponding checkboxes. To deny access to an individual resource, uncheck the related checkbox. To grant (or deny) access to all resources in a displayed group, click All or None.
2. Click **Apply**.

### To set an LDAP group's access level:

1. For the LDAP group name displayed in the list, click the Edit link. The LDAP Group Edit page displays.
2. From the Access Level drop-down menu, select the desired user access level as described in the table below.
3. Click **Apply**.

User Access Level (highest to lowest)	Description
Administrator	Administrative user; Full access for all configuration, all outlet power control actions (On, Off, Reboot), status, and serial/pass-thru ports.
Power User	Full access for all outlet power control actions (On, Off, Reboot), status, and serial/pass-thru ports. <b>Note: The Power User does not have access to user management.</b>
User	Partial access for outlet power control actions (On, Off, Reboot), status, and pass-thru of assigned outlets, outlet groups, and serial/pass-thru ports.
Reboot-Only User	Partial access for outlet power control actions (Reboot), status, and pass-thru of assigned outlets, outlet groups, and serial/pass-thru ports.
On-Only User	Partial access for outlet power control actions (On), status, and pass-thru of assigned outlets, outlet groups, and serial/pass-thru ports.
View-Only User	Partial access for status and pass-thru of assigned outlets, outlet groups, and serial/pass-thru ports.
System Monitor	Access to all "stat" commands on the Command Line Interface (CLI).

### To delete an LDAP group:

1. For the LDAP group name displayed in the list, click the Remove link. You will be prompted with a confirmation for the delete action.
2. Click **OK** or **Cancel**.

## Access > TACACS+ Privileges

The **TACACS+ Privileges** page allows the administrator to manage options for TACACS+ user groups, including establishing TACACS+ privilege levels and granting TACACS+ privilege level access to various areas of the PRO2.



**Note:** The PRO2 supports 16 different TACACS+ privilege levels with 15 configurable levels and 1 level (“0”) reserved by default for administrator-level access to all PRO2 resources.

Server Technology

- Overview
- Monitoring
- Control
- Configuration**
- System
- Network
- Access**
- General
- Local Users
- LDAP Groups
- TACACS+ Privileges**
- Tools

**TACACS+ Privilege Levels**

Edit or assign access rights to a TACACS+ privilege level

TACACS+ Privilege Level	Access Level	System Monitor	Access Rights	Action
0	User	No	Access	Edit
1	User	No	Access	Edit
2	User	No	Access	Edit
3	User	No	Access	Edit
4	User	No	Access	Edit
5	User	No	Access	Edit
6	User	No	Access	Edit
7	User	No	Access	Edit
8				
9				
10				
11				
12				
13	User	No	Access	Edit
14	User	No	Access	Edit
15	Admin	Yes	ALL	Edit

[TACACS+ Network Settings](#)

The TACACS+ Privileges page is for TACACS+ privilege management only. To configure parameters for the TACACS+ network protocol, go to **Configuration > Network > TACACS+**, or click the TACACS+ Network Settings link on this page.

### To set a TACACS+ privilege level:

1. For the TACACS+ Privilege Level displayed in the list, click the Edit link. The TACACS+ Privilege Level Edit page displays.
2. From the Access Level drop-down menu, select the desired user access level as described in the table below.
3. Click **Apply**.

User Access Level (highest to lowest)	Description
Administrator	Administrative user; Full access for all configuration, all outlet power control actions (On, Off, Reboot), status, and serial/pass-thru ports.
Power User	Full access for all outlet power control actions (On, Off, Reboot), status, and serial/pass-thru ports. <b>Note:</b> The Power User does not have access to user management.
User	Partial access for outlet power control actions (On, Off, Reboot), status, and pass-thru of assigned outlets, outlet groups, and serial/pass-thru ports.
Reboot-Only User	Partial access for outlet power control actions (Reboot), status, and pass-thru of assigned outlets, outlet groups, and serial/pass-thru ports.
On-Only User	Partial access for outlet power control actions (On), status, and pass-thru of assigned outlets, outlet groups, and serial/pass-thru ports.
View-Only User	Partial access for status and pass-thru of assigned outlets, outlet groups, and serial/pass-thru ports.
System Monitor	Access to all “stat” commands on the Command Line Interface (CLI).



***To grant access rights to a TACACS+ privilege level:***

1. For the TACACS+ Privilege Level displayed in the list, click the Access link. The TACACS+ Privilege Level Access page displays to allow granting access rights to selected PRO2 monitors, remote ports, outlet groups, and individual outlets by checking corresponding checkboxes. To deny access to an individual resource, uncheck the related checkbox. To grant (or deny) access to all resources in a displayed group, click All or None.
2. Click **Apply**.

## Tools (Using Support Functions)

The **Tools** section of the Web interface is a collection of several utility options for miscellaneous system actions: changing user password, pinging other network devices, viewing the system/debug log, and uploading new firmware versions.

Also included are several options for rebooting the PRO2, resetting the PRO2 to factory defaults, and restarting the PRO2 with user preferences.

### Tools > Change Password

This **Change Password** option allows firmware users to change their own passwords.

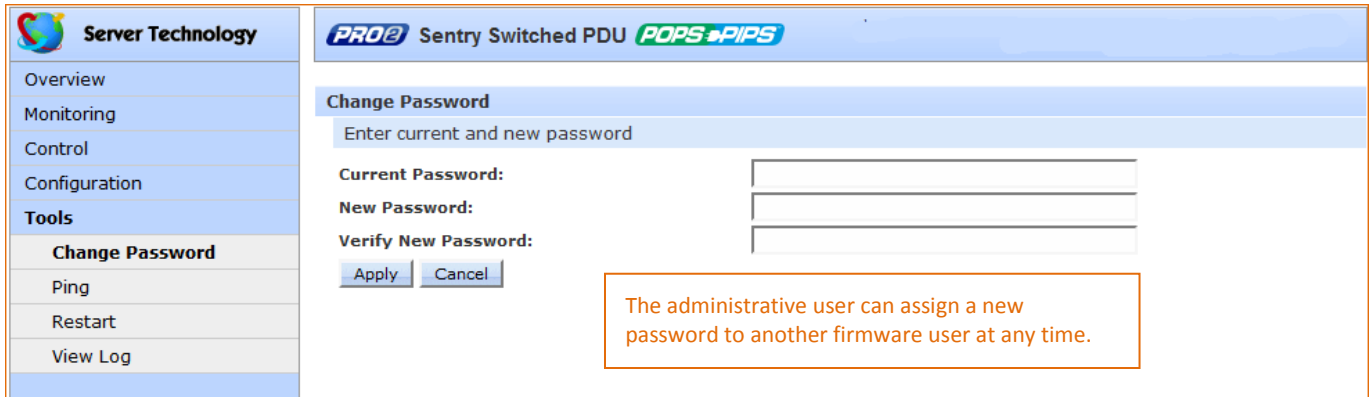

The screenshot shows the 'Change Password' web interface. On the left is a navigation menu with 'Tools' expanded to show 'Change Password'. The main content area has a header 'Change Password' and a sub-header 'Enter current and new password'. It contains three input fields: 'Current Password:', 'New Password:', and 'Verify New Password:'. Below these are 'Apply' and 'Cancel' buttons. A callout box on the right states: 'The administrative user can assign a new password to another firmware user at any time.'

#### **To change your password:**

1. Type your current password, your new password, and verify the new password.
2. Click **Apply**.

## Tools > Ping

The **Ping** option tests the ability of the PRO2 to contact the IP address of another Ethernet-enabled device.

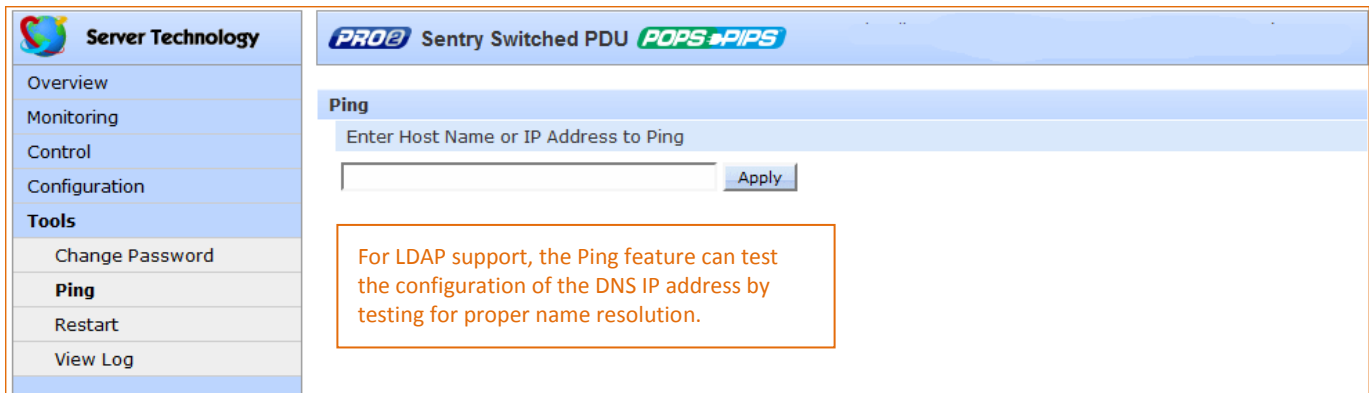

The screenshot shows the web interface for the PRO2 Sentry Switched PDU. On the left is a navigation menu with 'Server Technology' at the top, followed by 'Overview', 'Monitoring', 'Control', 'Configuration', and 'Tools'. Under 'Tools', there are links for 'Change Password', 'Ping', 'Restart', and 'View Log'. The main content area is titled 'Ping' and contains a text input field labeled 'Enter Host Name or IP Address to Ping' and an 'Apply' button. A callout box with an orange border contains the text: 'For LDAP support, the Ping feature can test the configuration of the DNS IP address by testing for proper name resolution.'

### ***To issue a ping:***

1. Type the hostname/IP address to ping (IPv4 or IPv6 format).
2. Click **Apply**.

If the ping was successful, a responding message is displayed, similar to:

10.1.1.70 is responding (<1ms)

## Tools > Restart

The **Restart** option offers several options for restarting the PRO2.

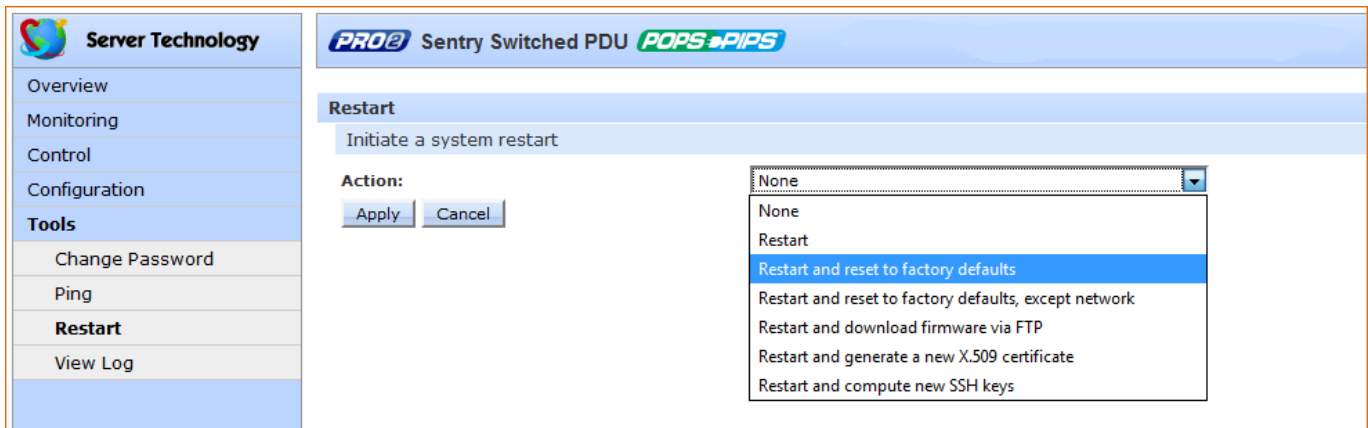

The screenshot shows the web interface for the PRO2 Sentry Switched PDU. On the left is a navigation menu with 'Server Technology' at the top, followed by 'Overview', 'Monitoring', 'Control', 'Configuration', 'Tools', 'Change Password', 'Ping', 'Restart', and 'View Log'. The 'Restart' option is highlighted. The main content area is titled 'Restart' and contains the text 'Initiate a system restart'. Below this is an 'Action:' label and two buttons: 'Apply' and 'Cancel'. To the right of the 'Apply' button is a drop-down menu currently set to 'None'. The menu is open, showing the following options: 'None', 'Restart', 'Restart and reset to factory defaults' (which is highlighted in blue), 'Restart and reset to factory defaults, except network', 'Restart and download firmware via FTP', 'Restart and generate a new X.509 certificate', and 'Restart and compute new SSH keys'.

### ***To initiate a system restart:***

1. From the Action drop-down menu, select a restart option as described in the table below.
2. Click **Apply**.

## Restart Options for the PRO2:



**Note:** PRO2 products support unit persistence. This means that if a link unit is connected to a master unit, and the link unit is disconnected (powered down or accidentally disconnected), and the master unit is restarted, the link unit will be reported as “Not Found” after the restart because the link unit is no longer physically connected to the master.

However, the association between the master/link units is retained to allow the continuation of alerts. If the disconnected link unit is physically re-connected to the master, the “Not Found” status will return to “Normal” status.

To intentionally remove a link unit from connection with a master unit, the link unit must be purged using the Purge function.

Unit persistence affects **all connected PRO2 master/link units** whether or not they are connected in a multi-linking configuration.

This restart option...	performs this action on the PRO2...
Restart	Performs a warm boot; system user/outlet/outlet group configuration settings and outlet states are <b>not</b> changed or reset with the <b>restart</b> command.
Restart and reset to factory defaults	Resets the non-volatile RAM where configuration values are stored. This option clears all administrator-editable fields and resets all CLI configurable options to their factory default values, including all user accounts.  Resetting the PRO2 to factory default values also resets all TCP/IP and Telnet/Web configurations. Reconfiguring TCP/IP and Telnet/Web settings is required.
Restart and reset to factory defaults, except network	Same action as “Restart and reset to factory defaults” described directly above, but network protocol settings are <b>not</b> changed.
Restart and download firmware via FTP	New versions of firmware can be uploaded using FTP. To begin an FTP upload session, you must first configure the FTP host address, username/password, filename, and filepath.  When initiating an FTP upload session, the PRO2 restarts and uploads the firmware file specified with the FTP filename command from the previously configured FTP host.
Restart and generate a new X.509 certificate	Generates a new X.509 certificate issued and signed by a certificate-authority.
Restart and compute new SSH keys	Generates new private and public SSH keys with the proper location and permission.

## About the Reset Button on the PRO2 Unit:

The PRO2 is designed with a **Reset** button on the hardware unit that can be used when a forgotten firmware password prevents logging into the unit. The **Reset** button sets all configuration values back to factory default settings, allowing the administrator to retrieve the admn/admn default administrator login.

To access the button on the unit, you need a non-conductive metallic tool that fits inside the recess. If you press and hold the **Reset** button on the unit for more than 15 seconds, the reset action will terminate.



**Note:** This method of physical access to the unit will not work if the **Reset** button has already been disabled by the administrator through the firmware GUI at **Configuration > Access > General > Configuration Reset Button**, or through the firmware CLI with the **set access button [enabled/disabled]** command. For security, the administrator can choose to disable the button through firmware to inhibit a user from causing a reset on the unit.

## Tools > View Log

This tool displays the internal system event log for viewing by the administrative user. The log records all authentication attempts, power actions, configuration changes, and other system events, and also supports email notifications.

System memory stores more than 4000 entries in a continuously aging log. For permanent off-system log storage, the Syslog protocol is supported.

Server Technology  
PRO2 Sentry Switched PDU POPS+PIPS  
IP Address : 10.1.2.65 Access : Admin

**View Log**

Log Filter:  Filter Clear

System log message list

Index	Date/Time	Lvl	Type	Message
1	Not Available	6	EVENT	Network stack started
2	Not Available	6	EVENT	System boot complete
3	Nov 26 11:17:23	2	EVENT	Over limit (power 494W) detected on cord 'Link1_Cord_A' [BA]
4	Nov 26 11:17:23	2	EVENT	Over limit (apparent power 496VA) detected on cord 'Link1_Cord_A' [BA]
5	Nov 26 11:17:23	2	EVENT	Over limit (current 2.10A) detected on line 'BA:L1' [BA1]
6	Nov 26 11:17:23	2	EVENT	Over limit (current 1.94A) detected on line 'BA:L3' [BA3]
7	Nov 26 11:17:23	3	EVENT	Read error detected on line 'BA:N' [BA4]
8	Nov 26 11:17:23	2	EVENT	High alarm (voltage 235.5V) detected on phase 'BA:L1-N' [BA1]
9	Nov 26 11:17:23	2	EVENT	High alarm (voltage 237.7V) detected on phase 'BA:L2-N' [BA2]
10	Nov 26 11:17:23	2	EVENT	High alarm (voltage 237.0V) detected on phase 'BA:L3-N' [BA3]
11	Nov 26 11:17:23	2	EVENT	Over limit (current 2.05A) detected on branch 'BA:Branch_6' [BA6]
12	Nov 26 11:17:23	5	EVENT	Normal current restored on line 'BA:L1' [BA1]
13	Nov 26 11:17:23	5	EVENT	Normal current restored on line 'BA:L3' [BA3]
14	Nov 26 11:17:23	5	EVENT	Normal voltage restored on phase 'BA:L1-N' [BA1]
15	Nov 26 11:17:23	5	EVENT	Normal voltage restored on phase 'BA:L2-N' [BA2]
16	Nov 26 11:17:23	5	EVENT	Normal voltage restored on phase 'BA:L3-N' [BA3]
17	Nov 26 11:17:23	5	EVENT	Normal current restored on branch 'BA:Branch_6' [BA6]
18	Nov 26 11:17:24	5	EVENT	Normal power restored on cord 'Link1_Cord_A' [BA]
19	Nov 26 11:17:24	5	EVENT	Normal apparent power restored on cord 'Link1_Cord_A' [BA]
20	Nov 26 11:23:24	6	AUTH	User 'admn' logged in from 10.1.7.25 using HTTP
21	Nov 26 11:31:02	6	CONFIG	Group 'Bldg1-A' created by admn
22	Nov 26 11:31:24	6	CONFIG	Group 'Bldg1-A' removed by admn
23	Nov 26 11:31:34	6	CONFIG	Group 'Building1_A' created by admn

### To filter the system log:

1. Type a text string in the Log Filter box.
2. Click the **Filter** button. The system/debug log is searched by the entered text and displays only the matching entries. To clear the filtered page and return to a full system log, click the **Clear** button.

This example shows the filtered results of the system log (highlighted in the example) filtered by “BA:L1”.

Server Technology PRO2 Sentry Switched PDU POPS+PIPS Location : Location Must Exist To Blink User : admin IP Address : 10.1.2.65 Access : Admin

View Log

Log Filter: BA:L1 Filter Clear

System log message list Change

Index	Date/Time	Lvl	Type	Message
5	Nov 26 11:17:23	2	EVENT	Over limit (current 2.10A) detected on line 'BA:L1' [BA1]
8	Nov 26 11:17:23	2	EVENT	High alarm (voltage 235.5V) detected on phase 'BA:L1-N' [BA1]
12	Nov 26 11:17:23	5	EVENT	Normal current restored on line 'BA:L1' [BA1]
14	Nov 26 11:17:23	5	EVENT	Normal voltage restored on phase 'BA:L1-N' [BA1]

<< First Page < Previous Page Next Page > Last Page >>

<< First Page < Previous Page Next Page > Last Page >>

Browse the system (or debug) log by using the page navigation links at the top and bottom of the log.

### To sort system log entries:

The entries in the System/Debug Log can be displayed in ascending or descending order (based on the internal index number in the Index column) by clicking one of the following icons:

For ascending order, click . For descending order, click .

### About the index:

The index number is assigned internally to control the sequence and identity of displayed System/Debug Log entries. The Index cannot be user-edited.

### Date/Time stamp:

The date and time stamp records the details of the system event timeframe. To display the date/time stamp, SNTP server support must be configured.

### Level (Lvl):

Indicates the level of the status icons displayed in the System Log.

### Type:

The System Log supports the following types of event messages:

AUTH: All attempts to authenticate

CONFIG: All changes in system configuration





EVENT: All general system events, for example, exceeded threshold limits

POWER: All requests for a power state change

### Message text:

A text line that describes the detailed parameters of the event. If the event is associated with a user, the user's name will be included in the message text.

## System log status icons:

	Normal
	Configuration Change
	Low/High Warning
	Low/High Alarm

## Options for Log Viewing

Viewing options for the System Log are set on the **Configuration > Access** page:

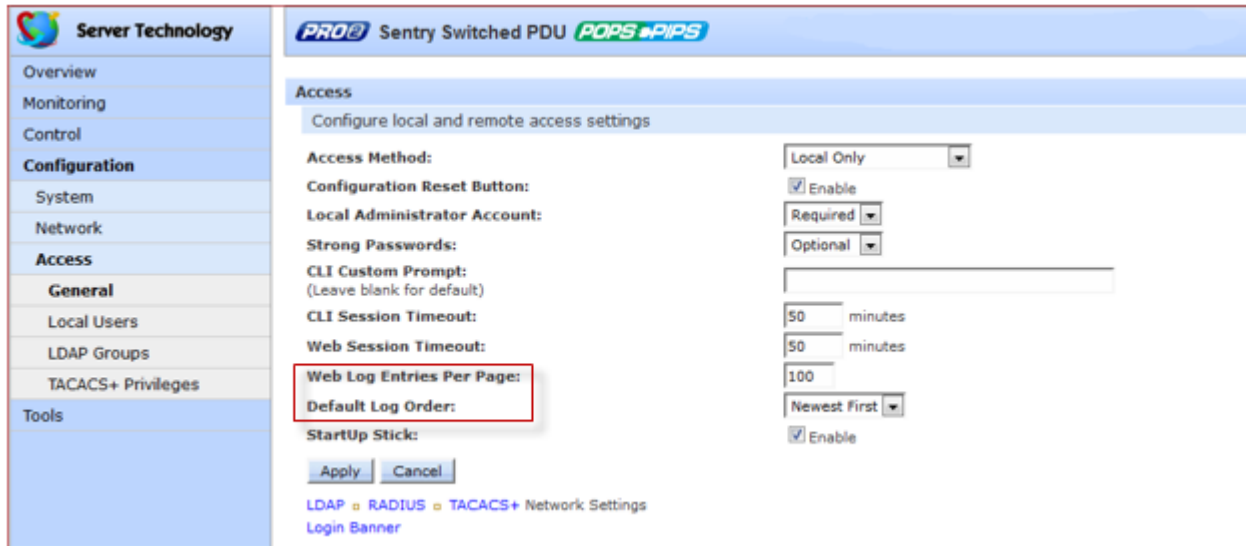

The screenshot shows the configuration page for Sentry Switched PDU. The page is titled "Access" and contains the following settings:

- Access Method: Local Only
- Configuration Reset Button:  Enable
- Local Administrator Account: Required
- Strong Passwords: Optional
- CLI Custom Prompt: (Leave blank for default)
- CLI Session Timeout: 50 minutes
- Web Session Timeout: 50 minutes
- Web Log Entries Per Page: 100
- Default Log Order: Newest First
- Startup Stick:  Enable

The "Web Log Entries Per Page" and "Default Log Order" settings are highlighted with a red box.

- **Web Log Entries Per Page:** Specifies the number of entries displayed on the System Log and the Debug Log. The maximum number of entries in the Debug Log can be set to 4,000. If the total number of entries exceed the maximum entries allowed, then Syslog will be used.
- **Default Log Order:** Sets the display of the Debug Log to the newest entry first or the oldest entry first.



## The Debug Log

Along with the System Log, the Debug Log is also provided. The Change link on each log toggles between logs, as illustrated in the following two examples:

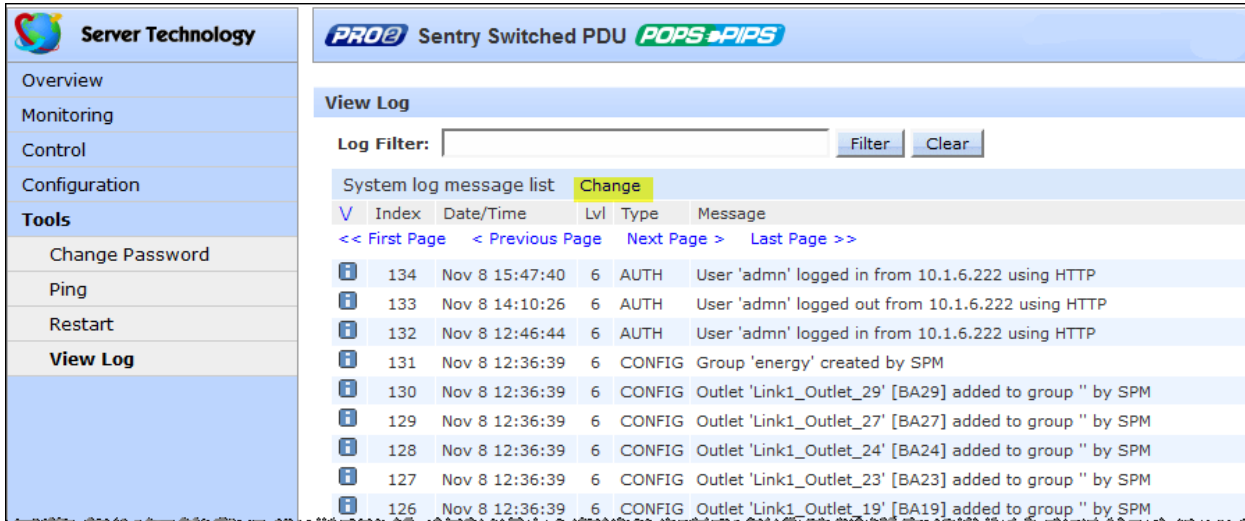

The screenshot shows the 'View Log' section of the web interface. The 'System log message list' is displayed with a 'Change' link highlighted in yellow. The log entries are as follows:

V	Index	Date/Time	Lvl	Type	Message		
<<	First Page	<	Previous Page	Next Page	>	Last Page	>>
	134	Nov 8 15:47:40	6	AUTH	User 'admn' logged in from 10.1.6.222 using HTTP		
	133	Nov 8 14:10:26	6	AUTH	User 'admn' logged out from 10.1.6.222 using HTTP		
	132	Nov 8 12:46:44	6	AUTH	User 'admn' logged in from 10.1.6.222 using HTTP		
	131	Nov 8 12:36:39	6	CONFIG	Group 'energy' created by SPM		
	130	Nov 8 12:36:39	6	CONFIG	Outlet 'Link1_Outlet_29' [BA29] added to group '' by SPM		
	129	Nov 8 12:36:39	6	CONFIG	Outlet 'Link1_Outlet_27' [BA27] added to group '' by SPM		
	128	Nov 8 12:36:39	6	CONFIG	Outlet 'Link1_Outlet_24' [BA24] added to group '' by SPM		
	127	Nov 8 12:36:39	6	CONFIG	Outlet 'Link1_Outlet_23' [BA23] added to group '' by SPM		
	126	Nov 8 12:36:39	6	CONFIG	Outlet 'Link1_Outlet_19' [BA19] added to group '' by SPM		

Click the Change link from the System Log (above) to display the following Debug Log:

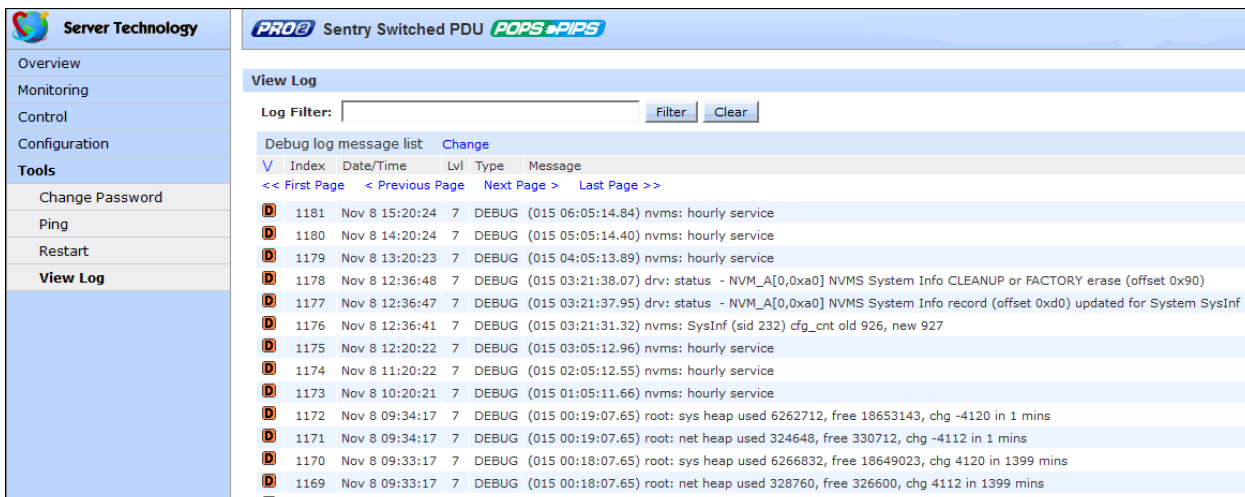

The screenshot shows the 'View Log' section of the web interface. The 'Debug log message list' is displayed with a 'Change' link highlighted in blue. The log entries are as follows:

V	Index	Date/Time	Lvl	Type	Message		
<<	First Page	<	Previous Page	Next Page	>	Last Page	>>
	1181	Nov 8 15:20:24	7	DEBUG	(015 06:05:14.84) nvms: hourly service		
	1180	Nov 8 14:20:24	7	DEBUG	(015 05:05:14.40) nvms: hourly service		
	1179	Nov 8 13:20:23	7	DEBUG	(015 04:05:13.89) nvms: hourly service		
	1178	Nov 8 12:36:48	7	DEBUG	(015 03:21:38.07) drv: status - NVM_A[0,0xa0] NVMS System Info CLEANUP or FACTORY erase (offset 0x90)		
	1177	Nov 8 12:36:47	7	DEBUG	(015 03:21:37.95) drv: status - NVM_A[0,0xa0] NVMS System Info record (offset 0xd0) updated for System SysInf		
	1176	Nov 8 12:36:41	7	DEBUG	(015 03:21:31.32) nvms: SysInf (sid 232) cfg_cnt old 926, new 927		
	1175	Nov 8 12:20:22	7	DEBUG	(015 03:05:12.96) nvms: hourly service		
	1174	Nov 8 11:20:22	7	DEBUG	(015 02:05:12.55) nvms: hourly service		
	1173	Nov 8 10:20:21	7	DEBUG	(015 01:05:11.66) nvms: hourly service		
	1172	Nov 8 09:34:17	7	DEBUG	(015 00:19:07.65) root: sys heap used 6262712, free 18653143, chg -4120 in 1 mins		
	1171	Nov 8 09:34:17	7	DEBUG	(015 00:19:07.65) root: net heap used 324648, free 330712, chg -4112 in 1 mins		
	1170	Nov 8 09:33:17	7	DEBUG	(015 00:18:07.65) root: sys heap used 6266832, free 18649023, chg 4120 in 1399 mins		
	1169	Nov 8 09:33:17	7	DEBUG	(015 00:18:07.65) root: net heap used 328760, free 326600, chg 4112 in 1399 mins		

The icons, fields and information columns shown on the Debug Log function the same way as described for the System Log with the following exceptions:

- The only log type is DEBUG.
- The only icon displayed on log entries indicates a debug entry: .

To return to the System Log, click the Change link again.

## Chapter 5: Using the Command Line Interface (CLI)

This chapter shows how to work with the firmware CLI (version 8.0x or later) for the PRO2.

### Logging In

Logging in through Telnet requires directing the Telnet client to the configured IP address of the unit.

A login through the console (RS232) port requires the use of a terminal or terminal emulation software configured to support ANSI or VT100, and a supported data rate of 300, 1200, 2400, 4800, 9600, 19200, 38400, 57600, or 115200 bps (default rate is 9600); 8 data bits-no parity, 1 stop bit, and device ready output signal (DTR or DSR).

#### **To login by Telnet or RS232 (CLI):**

At the command prompt, initiate a Telnet session (telnet [IP address]). The Telnet session automatically opens the login prompt, showing the current product and firmware version.

```
Sentry Switched CDU Version 8.0
Username: admn
Password:
Location:
Switched CDU:
```

The default administrative-level user login (admn/admn) was used for this example.

Press **Enter**.

The command line prompt, such as “Switched CDU:” (for Cabinet Distribution Unit) in this example, displays for the PRO2 product, and you are now logged into the firmware Command Line Interface (CLI).

If a location identifier was user-defined, that location will also be displayed, as shown in the example.

### Quick Tour of the Command Line

The features and requirements of the command line are presented in this section.

#### **Running Commands**

To run a command, type the command, and while it is displayed on the command line, press **Enter**.

When a command is used to edit configuration settings, the values will be updated immediately.

Commands can be typed in any combination of uppercase and lowercase characters. All characters in the command must be entered correctly and command abbreviations are invalid.

If an invalid command or an incorrectly typed command is entered, one of the following messages displays:

- “Invalid parameter” with a display of the correct menu options, or
- “[command] is not recognized as an internal or external command, operable program, or batch file.”

#### **Using the Escape (ESC) Feature**

At any time during the typing of a command, press **ESC** to cancel and clear all typed characters from the command line.

Even when setting a user password or other command where a specific prompt has displayed, pressing **ESC** quickly cancels the displayed prompt and the typed command.

## Using CTRL-C to Cancel Commands

CLI command operations can be cancelled by using the keys CTRL-C, where applicable.

## Editing Commands

Several editing actions are available when typing a command:

This edit action...	does this on the command line...
Left Arrow ←	Moves cursor to the left to correct a typed character.
Right Arrow →	Moves cursor to the right to correct a typed character.
Backspace Key	Deletes typed command one character at a time.
Insert Key	Inserts a character in the command.
Delete Key	Deletes a character in the command.
Home Key	Moves to the first character of the command.
End Key	Moves to the last character of the command.
Esc	Clears typed characters from the command line.
CTRL-C	Cancels CLI operations, where applicable.

## Retrieving Command History

The CLI provides a command history feature for the last X commands entered, using the **Up** and **Down** keys.

To display a previously entered command, press the ↑ arrow key. After the ↑ arrow key has been pressed, you can then press the ↓ arrow key to display a previously entered command in reverse order. Pressing the keys displays one command at a time.

To erase the command history, press **Esc**.

## Displaying the Command Menu

The main menu of valid top-level commands can be displayed at any time during a CLI session.

At the command prompt, do one of the following:

- Type **help** and press **Enter**
- Type **?** and press **Enter**

### Example:

```
Switched CDU: help
```

```
Switched CDU commands:
```

```
add bstat connect create cstat delete dir list login logmon
logout lstat ocpstat off on ostat password ping pstat reboot
remove restart senstat set show shutdown status sysstat upsstat
ustat version
```

### Example:

```
Switched CDU: ?
```

```
Switched CDU commands:
```

```
add bstat connect create cstat delete dir list login logmon
logout lstat ocpstat off on ostat password ping pstat reboot
remove restart senstat set show shutdown status sysstat upsstat
ustat version
```

## Displaying the Submenus

To view submenus of valid options for a command, type the main command and press **Enter**:

### Example:

```
Switched CDU: set
```

```
'set' menu options:
```

```
access banner bluetooth branch config cord dhcp dns email
energywise feature ftp http https ipv4 ipv6 ldap ldapgroup line
loadshed location net ocp outlet phase port radius sensor snmp
snmp spm ssh syslog tacacs tacpriv telnet unit ups user
```

### Example::

```
Switched CDU: show
```

```
'show' menu options:
```

```
access bluetooth branches config cords email energywise features
ftp ldap lines loadshed log network ocps outlets phases ports
radius sensors shutdown snmp snmp syslog system tacacs units ups
```

## Command Syntax Notes

The following conventions apply to the command syntax shown in the Command Details section:

[argument] mandatory argument that is not prompted for.

[*argument*] optional argument that is not prompted for.

<argument> argument that will be prompted for if not specified on the command line.

{argument} argument that can only be prompted for.

### Example (set access command):

#### set access

Sets user access configurations.

#### Command Syntax

```
set access button [disabled | enabled]
set access clitimeout <value>
set access localadmin [required | optional]
set access logorder [newest | oldest]
set access method [localonly | ldaponly | ldaplocal | radiusonly | radiuslocal |
tacacsonly | tacacslocal]
set access prompt <prompt string>
set access strongpw [optional | required]
set access webloglen <value>
set access webtimeout <value>
```

## List of Commands

Click a linked command name in the following table to display detailed information about using the command.

Command	Description
<b>Add Commands</b>	<b>The Add command group adds control access for outlets/outlet groups, and connection pass-thru to specified ports for LDAP, TACACS+, and local users.</b>
<a href="#">add grouptoldap</a>	Adds control access for an outlet group to an LDAP group.
<a href="#">add grouptotacacs</a>	Adds control access for an outlet group to a TACACS+ privilege level.
<a href="#">add grouptouser</a>	Adds control access for an outlet group to a local user.
<a href="#">add outlettogroup</a>	Adds control access for an outlet to an outlet group.
<a href="#">add outlettoldap</a>	Adds control access for an outlet to an LDAP group.
<a href="#">add outlettotacacs</a>	Adds control access for an outlet to a TACACS+ privilege level.
<a href="#">add outlettouser</a>	Adds control access for an outlet to a local user.
<a href="#">add porttoldap</a>	Adds access to use a connection pass-thru to a specified port to an LDAP group.
<a href="#">add porttotacacs</a>	Adds access to use a connection pass-thru to a specified port to a TACACS+ privilege level.
<a href="#">add porttouser</a>	Adds access to use a connection pass-thru to a specified port to a local user.
<a href="#">bstat</a>	Displays the latest status and metrics for all branches in the system.
<a href="#">connect</a>	Redirects the current CLI session to the target port.
<b>Create Commands</b>	<b>The Create command group creates new outlet groups, LDAP groups, UPS devices, and local users.</b>
<a href="#">create group</a>	Creates a new outlet group.
<a href="#">create ldapgroup</a>	Creates a new LDAP group.
<a href="#">create ups</a>	Creates a new uninterruptable power supply (UPS).
<a href="#">create user</a>	Creates a new local user.
<a href="#">cstat</a>	Displays the latest status and metrics for all cords in the system.
<b>Delete Commands</b>	<b>The Delete command group deletes access for outlets, outlet groups, and connection pass-thru to a specified port from LDAP groups, TACACS+ privilege levels, and local users.</b>
<a href="#">delete groupfromldap</a>	Deletes control access for an outlet group from an LDAP group.
<a href="#">delete groupfromtacacs</a>	Deletes control access for an outlet group from a TACACS+ privilege level.
<a href="#">delete groupfromuser</a>	Deletes control access for an outlet group from a local user.
<a href="#">delete outletfromgroup</a>	Deletes control access for an outlet from an outlet group.

Command	Description
<a href="#">delete outletfromldap</a>	Deletes control access for an outlet from an LDAP group.
<a href="#">delete outletfromtacacs</a>	Deletes control access for an outlet from a TACACS+ privilege level.
<a href="#">delete outletfromuser</a>	Deletes control access for an outlet from a local user.
<a href="#">delete portfromldap</a>	Deletes access to use a connection pass-thru to a specified port from an LDAP group
<a href="#">delete portfromtacacs</a>	Deletes access to use a connection pass-thru to a specified port from a TACACS+ privilege level.
<a href="#">delete portfromuser</a>	Deletes access to use a connection pass-thru to a specified port to a local user.
<a href="#">dir</a>	Directory; displays the contents of the active working path in the file system.
<b>List Commands</b>	<b>The List command displays outlets in an outlet group, users, user groups, outlets, ports, and TACACS+ privileges.</b>
<a href="#">list group</a>	Lists the outlets that are collected in an outlet group.
<a href="#">list groups</a>	Lists all outlet groups.
<a href="#">list ldapgroup</a>	Lists the access level of an LDAP group and any outlet groups, outlets, and ports assigned to that LDAP group.
<a href="#">list ldapgroups</a>	Lists all LDAP groups.
<a href="#">list outlets</a>	Lists all outlets.
<a href="#">list ports</a>	Lists all ports.
<a href="#">list tacpriv</a>	Lists the access level of a TACACS+ privilege level and any outlet groups, outlets, and ports assigned to that TACACS+ privilege level.
<a href="#">list tacprivs</a>	Lists all TACACS+ privilege levels.
<a href="#">list user</a>	Lists the access level of a local user and any outlet groups, outlets, and ports assigned to that user.
<a href="#">list users</a>	Lists all local users.
<a href="#">login</a>	Performs system login and access verification.
<a href="#">logmon</a>	Displays the system log (monitor) messages in the CLI session as they occur.
<a href="#">logout</a>	Quits the current CLI session.
<a href="#">lstat</a>	Displays the latest status and metrics for all lines in the system.
<a href="#">ocpstat</a>	Displays the latest status and metrics for all over-current protectors (OCPs) in the system.
<a href="#">off</a>	Turns off the specified outlet or outlet group.

Command	Description
<a href="#">on</a>	Turns on the specified outlet or outlet group.
<a href="#">ostat</a>	Displays the latest status and metrics for all outlets in the system.
<a href="#">password</a>	Changes the password for the current local user.
<a href="#">ping</a>	Tests the ability of the PRO2 to contact an IP address for another Ethernet-enabled device.
<a href="#">pstat</a>	Displays the latest status and metrics for all phases in the system.
<a href="#">reboot</a>	Turns off the specified outlet or outlet group, and then turns it back on after a delay.
<b>Remove Commands</b>	<b>The Remove command group removes outlet groups, LDAP groups, UPS devices, and local users from the system.</b>
<a href="#">remove_group</a>	Removes an outlet group from the system.
<a href="#">remove_ldapgroup</a>	Removes an LDAP group from the system.
<a href="#">remove_ups</a>	Removes a UPS from the system.
<a href="#">remove_user</a>	Removes a local user from the system.
<a href="#">restart</a>	Restarts the system.
<a href="#">senstat</a>	Displays the latest status and metrics for all sensors in the system.
<b>Set Commands</b>	<b>The Set command group sets the configuration values for numerous system areas.</b>
<a href="#">set_access</a>	Sets user configuration access.
<a href="#">set_banner</a>	Sets the system banner that displays before a user authenticates a user session.
<a href="#">set_bluetooth</a>	Sets Bluetooth® configuration values.
<a href="#">set_branch</a>	Sets branch configuration values.
<a href="#">set_cord</a>	Sets cord configuration values.
<a href="#">set_dhcp</a>	Sets DHCP configuration values.
<a href="#">set_dns</a>	Sets Domain Name System (DNS) server configuration values.
<a href="#">set_email</a>	Sets email configuration values.
<a href="#">set_energywise</a>	Sets Cisco EnergyWise configuration values.
<a href="#">set_feature</a>	Enables new system features.
<a href="#">set_ftp</a>	Sets FTP configuration values.
<a href="#">set_http</a>	Sets HTTP configuration values.

Command	Description
<a href="#">set https</a>	Sets HTTPS configuration values.
<a href="#">set ipv4, set ipv6</a>	Sets IPv4 and IPv6 configuration values.
<a href="#">set ldap</a>	Sets LDAP configuration values.
<a href="#">set ldapgroup</a>	Sets configuration values for LDAP group access rights.
<a href="#">set line</a>	Sets line configuration values.
<a href="#">set loadshed</a>	Sets Smart Load Shedding configuration values. <b>Note:</b> Only available if the Smart Load Shedding feature is activated.
<a href="#">set location</a>	Sets the system location string.
<a href="#">set net</a>	Sets network mode configuration values.
<a href="#">set ocp</a>	Sets over-current protector (OCP) configuration values.
<a href="#">set outlet</a>	Sets outlet configuration values.
<a href="#">set phase</a>	Sets phase configuration values.
<a href="#">set port</a>	Sets serial port configuration values.
<a href="#">set radius</a>	Sets Radius server configuration values.
<a href="#">set sensor</a>	Sets sensor configuration values.
<a href="#">set snmp</a>	Sets SNMP configuration values.
<a href="#">set sntp</a>	Sets SNTP configuration values.
<a href="#">set spm</a>	Sets Sentry Power Manager (SPM) access configuration values.
<a href="#">set ssh</a>	Sets SSH configuration values.
<a href="#">set syslog</a>	Sets Syslog configuration values.
<a href="#">set tacacs</a>	Sets TACACS+ server configuration values.
<a href="#">set tacpriv</a>	Sets TACACS+ configuration values for privilege level access rights.
<a href="#">set telnet</a>	Sets Telnet configuration values.
<a href="#">set trend</a>	Sets power trending configurations.
<a href="#">set unit</a>	Sets PRO2 configuration values.
<a href="#">set ups</a>	Sets UPS device configuration values.



Command	Description
<a href="#">set user</a>	Sets configuration values for local user access rights.
<a href="#">set wlan</a>	Sets the wireless network configuration (for the WLAN solution on specific Wi-Fi capable PRO2 units).
<b>Show Commands</b>	<b>The Show command group displays the current configuration values in the system.</b>
<a href="#">show access</a>	Shows user access configuration values.
<a href="#">show bluetooth</a>	Shows Bluetooth configuration values.
<a href="#">show branches</a>	Shows branch configuration values.
<a href="#">show cords</a>	Shows cord configuration values.
<a href="#">show email</a>	Shows email configuration values.
<a href="#">show energywise</a>	Shows Cisco EnergyWise configuration values.
<a href="#">show features</a>	Shows the enabled system features.
<a href="#">show ftp</a>	Shows FTP configuration values.
<a href="#">show ldap</a>	Shows LDAP configuration values.
<a href="#">show lines</a>	Shows line configuration values.
<a href="#">show loadshed</a>	Shows Smart Load Shedding configuration values. <b>Note:</b> Only available if the Smart Load Shedding feature is activated.
<a href="#">show log</a>	Shows the system event log.
<a href="#">show network</a>	Shows network configuration values.
<a href="#">show ocps</a>	Shows over-current protector (OCP) configuration values.
<a href="#">show outlets</a>	Shows outlet configuration values.
<a href="#">show phases</a>	Shows phase configuration values.
<a href="#">show ports</a>	Shows port configuration values.
<a href="#">show radius</a>	Shows Radius server configuration values.
<a href="#">show sensors</a>	Shows sensor configuration values.
<a href="#">show shutdown</a>	Shows outlet shutdown configuration values.
<a href="#">show snmp</a>	Shows SNMP configuration values.
<a href="#">show sntp</a>	Shows SNTP configuration values.

Command	Description
<a href="#">show syslog</a>	Shows Syslog configuration values.
<a href="#">show system</a>	Shows system uptime, firmware version, firmware build information, boot version, number of active users, and location string.
<a href="#">show tacacs</a>	Shows TACACS+ configuration values.
<a href="#">show trend</a>	Shows power trending configurations.
<a href="#">show units</a>	Shows PRO2 configuration values.
<a href="#">show ups</a>	Shows UPS device configuration values.
<a href="#">show waps</a>	Displays the available wireless access points (for the WLAN solution on specific Wi-Fi capable PRO2 units).
<a href="#">show wlan</a>	Displays the wireless network configurations (for the WLAN solution on specific Wi-Fi capable PRO2 units).
<a href="#">shutdown</a>	Turns off a specified outlet or outlet group after performing a user-specified shutdown operation.
<a href="#">status</a>	Displays the latest status and control state for a specified outlet or outlet group.
<a href="#">sysstat</a>	Displays the count of all system objects (by type), the latest status of the objects, and the count of objects currently in an event condition.
<a href="#">upsstat</a>	Displays the latest status and metrics for all UPS devices in the system.
<a href="#">ustat</a>	Displays the latest status and metrics for all PRO2 units in the system.
<a href="#">version</a>	Displays the current firmware version.

## Command Details

### add grouptoldap

Adds control access for an outlet group to an LDAP group.

#### Command Syntax

```
add grouptoldap <group name | ALL> <LDAP group name>  
add gtl <group name | ALL> <LDAP group name>
```

#### Command Access

Admin level only

### add grouptotacacs

Adds control access for an outlet group to an TACACS+ privilege level.

#### Command Syntax

```
add grouptotacacs <group name | ALL> <TACACS+ privilege level>  
add gtl <group name | ALL> <TACACS+ privilege level>
```

#### Command Access

Admin level only

### add grouptouser

Adds control access for an outlet group to a local user.

#### Command Syntax

```
add grouptouser <group name | ALL> <local user name>  
add gtu <group name | ALL> <local user name>
```

#### Command Access

Admin level only

### add outlettogroup

Adds control access for an outlet to an outlet group.

#### Command Syntax

```
add outlettogroup <outlet name | id | ALL> <group name>  
add otg <outlet name | id | ALL> <group name>
```

#### Command Access

Admin level only

## add outlettoldap

Adds control access for an outlet to an LDAP group.

### Command Syntax

```
add outlettoldap <outlet name | id | ALL> <LDAP group name>  
add otl <outlet name | id | ALL> <LDAP group name>
```

### Command Access

Admin level only

## add outlettotacacs

Adds control access for an outlet to a TACACS+ privilege level.

### Command Syntax

```
add outlettotacacs <outlet name | id | ALL> <TACACS+ privilege level>  
add ott <outlet name | id | ALL> <TACACS+ privilege level>
```

### Command Access

Admin level only

## add outlettouser

Adds control access for an outlet to a local user.

### Command Syntax

```
add outlettouser <outlet name | id | ALL> <local user name>  
add otu <outlet name | id | ALL> <local user name>
```

### Command Access

Admin level only

## add porttoldap

Adds access to use a connection pass-thru to a specified port to an LDAP group.

### Command Syntax

```
add porttoldap <port name | id | ALL> <LDAP group name>  
add ptl <port name | id | ALL> <LDAP group name>
```

### Command Access

Admin level only

## add porttotacacs

Adds access to use a connection pass-thru to a specified port to a TACACS+ privilege level.

### Command Syntax

```
add porttotacacs <port name | id | ALL> <TACACS+ privilege level>  
add ptt <port name | id | ALL> <TACACS+ privilege level>
```

### Command Access

Admin level only

## add porttouser

Adds access to use a connection pass-thru to a specified port to a local user.

### Command Syntax

```
add porttouser <port name | id | ALL> <local user name>  
add ptu <port name | id | ALL> <local user name>
```

### Command Access

Admin level only

## bstat

Displays the latest status and metrics for all branches in the system.

### Command Syntax

```
bstat
```

### Command Access

System Monitor access

## connect

Redirects the current CLI session to the target port.

### Command Syntax

```
connect <target port>
```

### Command Access

Any access level for command; for user level lower than admin, access must be granted to a port for successful connection.

## create group

Creates a new outlet group.

### Command Syntax

```
create group <name>
```

### Command Access

Admin level only

## create ldapgroup

Creates a new LDAP group.

### Command Syntax

```
create ldapgroup <name>
```

### Command Access

Admin level only

## create ups

Creates a new uninterruptable power supply (UPS).

### Command Syntax

```
create ups <name | ups type |> <hostname>
```

### Parameters

The **create ups** command uses the following parameters:

hostname	Hostname or IP address of the UPS.
ups type	Selects UPS type from list of manufacturers. (1-11).

### Command Access

Admin level only

## create user

Creates a new local user.

### Command Syntax

```
create user <name> {password} {verify password}
```

### Command Access

Admin level only

## cstat

Displays the latest status and metrics for all cords in the system.

### Command Syntax

```
cstat
```

### Command Access

System Monitor access

## delete groupfromldap

Deletes control access for an outlet group from an LDAP group.

### Command Syntax

```
delete groupfromldap <group name | ALL> <LDAP group name>  
delete gfl <group name | ALL> <LDAP group name>
```

### Command Access

Admin level only

## delete groupfromtacacs

Deletes control access for an outlet group from a TACACS+ privilege level.

### Command Syntax

```
delete groupfromtacacs <group name | ALL> <TACACS+ privilege level>  
delete gft <group name | ALL> <TACACS+ privilege level>
```

### Command Access

Admin level only

## delete groupfromuser

Deletes control access for an outlet group from a local user.

### Command Syntax

```
delete groupfromuser <group name | ALL> <local user name>  
delete gfu <group name | ALL> <local user name>
```

### Command Access

Admin level only

## delete outletfromgroup

Deletes control access for an outlet from an outlet group.

### Command Syntax

```
delete outletfromgroup <outlet name | id | ALL> <group name>  
delete ofg <outlet name | id | ALL> <group name>
```

### Command Access

Admin level only

## delete outletfromldap

Deletes control access for an outlet from an LDAP group.

### Command Syntax

```
delete outletfromldap <outlet name | id | ALL> <LDAP group name>  
delete ofl <outlet name | id | ALL> <LDAP group name>
```

### Command Access

Admin level only

## delete outletfromtacacs

Deletes control access for an outlet from a TACACS+ privilege level.

### Command Syntax

```
delete outletfromtacacs <outlet name | id | ALL> <TACACS+ privilege level>  
delete oft <outlet name | id | ALL> <TACACS+ privilege level>
```

### Command Access

Admin level only

## delete outletfromuser

Deletes control access for an outlet from a local user.

### Command Syntax

```
delete outletfromuser <outlet name | id | ALL> <local user name>  
delete ofu <outlet name | id | ALL> <local user name>
```

### Command Access

Admin level only

## delete portfromldap

Deletes access to use a connection pass-thru to a specified port from an LDAP group.

### Command Syntax

```
delete portfromldap <port name | id | ALL> <LDAP group name>  
delete pfl <port name | id | ALL> <LDAP group name>
```

### Command Access

Admin level only

## delete portfromtacacs

Deletes access to use a connection pass-thru to a specified port from a TACACS privilege level.

### Command Syntax

```
delete portfromtacacs <port name | id | ALL> <TACACS+ privilege level>  
delete pft <port name | id | ALL> <TACACS+ privilege level>
```

### Command Access

Admin level only



## delete portfromuser

Deletes access to use a connection pass-thru to a specified port to a local user.

### Command Syntax

```
delete portfromuser <port name | id | ALL> <local user name>  
delete pfu <port name | id | ALL> <local user name>
```

### Command Access

Admin level only

## dir

(Directory) Displays the contents of the active working path in the file system.

### Command Syntax

```
.  
dir [.]  
dir [path] [volume]
```

### Parameters

The **dir** command uses the following parameters.

“.”	Displays the current path.
path	Specifies a path.
volume	(FLASH0   RAM0)

### Command Access

Admin level only

## list group

Lists the outlets that are contained in an outlet group.

### Command Syntax

```
list group <group name | ALL>
```

### Command Access

Any access level

## list groups

Lists all outlet groups.

### Command Syntax

```
list groups
```

### Command Access

Any access level

## list ldapgroup

Lists access level of an LDAP group and any outlet groups, outlets, and ports assigned to that LDAP group.

### Command Syntax

list ldapgroup <LDAP group name>

### Command Access

Admin level only

## list ldapgroups

Lists all LDAP groups.

### Command Syntax

list ldapgroups

### Command Access

Admin level only

## list outlets

Lists all outlets.

### Command Syntax

list outlets

### Command Access

Any access level

## list ports

Lists all ports.

### Command Syntax

list ports

### Command Access

Any access level

## list tacpriv

Lists access level of a TACACS+ privilege level and any outlet groups, outlets, and ports assigned to that TACACS+ privilege level.

### Command Syntax

list tacpriv <TACACS+ privilege level>

### Command Access

Admin level only

## list tacprivs

Lists all TACACS+ privilege levels.

### Command Syntax

list tacprivs

### Command Access

Admin level only

## list user

Lists access level of a local user and any outlet groups, outlets, and ports assigned to that user.

### Command Syntax

list user <username>

### Command Access

Admin level only

## list users

Lists all local users.

### Command Syntax

list users

### Command Access

Admin level only

## login

Performs system login and access verification.

### Command Syntax

login

### Command Access

Any access level

## logmon

Log Monitor. Displays the system log (monitor) messages in the CLI session as they occur.

### Command Syntax

logmon [filter]

### Parameters

The **logmon** command uses the following parameter.

filter	Keyword filter for log entries.
--------	---------------------------------

### Usage Guidelines

The log monitor command runs until ESC or RETURN is pressed.

### Command Access

Admin level only

## logout

Quits the current CLI session.

### Command Syntax

logout

### Command Access

Any access level

## Istat

Displays the latest status and metrics for all lines in the system.

### Command Syntax

Istat

### Command Access

System monitor access

## ocpstat

Displays the latest status and metrics for all over-current protectors (OCPs) in the system.

### Command Syntax

ocpstat

### Command Access

System monitor access

## off

Turns off the specified outlet or outlet group.

### Command Syntax

off <name | id | group | ALL>

### Usage Guidelines

The **off** command is for Switched PRO2 products only.

### Command Access

User level and above

## on

Turns on the specified outlet or outlet group.

### Command Syntax

on <name | id | group | ALL>

### Usage Guidelines

The **on** command is for Switched PRO2 products only.

### Command Access

On-Only users or User level and above

## ostat

Displays the latest status and metrics for all outlets in the system.

### Command Syntax

ostat <name | outlet | outlet id | group | ALL>

### Command Access

System monitor access

## password

Changes the password for the current local user.

### Command Syntax

Password {password} {verify password}

### Command Access

Any access level

## ping

Tests the reachability of a host on the IP network.

### Command Syntax

ping <hostname>

### Parameters

The **ping** command uses the following parameter.

hostname	Specifies the host to ping, 0-63 characters.
----------	--

### Command Access

Any access level

## **pstat**

Displays the latest status and metrics for all phases in the system.

### **Command Syntax**

pstat

### **Command Access**

System monitor access

## **reboot**

Turns off the specified outlet or outlet group and then turns it back on after a delay.

### **Command Syntax**

reboot <name | id | group | ALL>

### **Usage Guidelines**

The Reboot command is for Switched PRO2 products only.

### **Command Access**

Reboot-Only users or User level and above

## **remove group**

Removes an outlet group from the system.

### **Command Syntax**

remove group <name>

### **Command Access**

Admin level only

## **remove ldapgroup**

Removes an LDAP group from the system.

### **Command Syntax**

remove ldapgroup <name>

### **Command Access**

Admin level only

## **remove ups**

Removes an uninterruptable power supply (UPS) from the system.

### **Command Syntax**

remove ups <name>

### **Command Access**

Admin level only

## remove user

Removes a local user from the system.

### Command Syntax

```
remove ups <name>
```

### Command Access

Admin level only

## restart

Restarts the system.

### Command Syntax

```
restart [factkeepnet | factory | ftpload | newx509cert | newsshkeys | normal]
```

### Parameters

The **restart** command uses the following parameters.

**Note:** None of the parameters in the following table performs a normal system restart.

factkeepnet	Removes all system configurations except network configuration.
factory	Removes all system configurations.
ftpload	Performs a system update through an FTP load.
newx509cert	Creates a new self-signed SSL X509 certificate.
newsshkeys	Creates a new set of public and private SSH keys.
normal	Performs a normal system restart.

### Command Access

Admin level only; no access in Demo mode

## senstat

Displays the latest status and metrics for all sensors in the system.

### Command Syntax

```
senstat
```

### Command Access

System monitor access

## set access

Sets user access configurations.

### Command Syntax

```
set access button [disabled | enabled]
set access clitimeout <value>
set access localadmin [required | optional]
set access logorder [newest | oldest]
set access method [localonly | ldaponly | ldaplocal | radiusonly | radiuslocal |
tacacsonly | tacacslocal]
set access prompt <prompt string>
set access startupstick [disabled | enabled ]
set access strongpw [optional | required]
set access webloglen <value>
set access webtimeout <value>
```

### Parameters

The **set access** command uses the following parameters:

button	Sets if the Configuration Reset button can reset the system configuration.
clitimeout	Set the CLI session idle time before automatic logout [1-1440 minutes].
localadmin	Removes the restriction to not allow the last local administrator to be removed when remote authentication (LDAP, TACACS+, or RADIUS) is in use.
logorder	Sets the default order of the system log when displayed.
method	Sets the allowed access methods for users.
prompt	Sets the system CLI prompt (0-32 characters).
startupstick	Enables/disables the Startup Stick tool for mass PDU configuration.
strongpw	Sets if strong passwords are required for local users.
webloglen	Sets the number of log entries per page when viewing the log on the Web [10-250 entries].
webtimeout	Sets the Web session idle time before automatic logout [1-1440 minutes].

### Sub-Parameters

The **set access** command uses the following sub-parameters:

localonly	Local authentication only.
ldaponly	Authentication using only the configured LDAP servers.
ldaplocal	Authentication using the configured LDAP servers, then locally if no LDAP match is found.
radiusonly	Authentication using only the configured Radius servers.
radiuslocal	Authentication using the configured Radius servers, then locally if no Radius match is found.
tacacsonly	Authentication using only the configured TACACS servers.
tacacslocal	Authentication using the configured TACACS+ servers, then locally if no TACACS+ match is found.



## Command Access

Admin level only

## set banner

Sets the system banner that displays before a user authenticates a user session.

## Command Syntax

```
set banner <banner text>
```

## Parameters

The **set banner** command uses the following sub-parameters:

banner text	Text for system banner, 0-2070 characters.
-------------	--

## Usage Guidelines

- The banner accepts all printable ASCII characters, plus CRLF.
- CTL-Z terminates banner input.

## Command Access

Admin level only; no access in Demo mode

## set bluetooth

Sets Bluetooth® configuration values.

## Command Syntax

```
set bluetooth [disabled | enabled]
set bluetooth discover [disabled | enabled | limited]
set bluetooth name <name>
set bluetooth pincode <value>
set bluetooth transpwr <value>
```

## Parameters

The **set bluetooth** command uses the following parameters:

discover	Sets the discoverability of the Bluetooth module.
name	Sets the name of the Bluetooth module (1-31 characters).
pincode	Sets the pin code used for Bluetooth pairing (0000-9999).
transpwr	Sets the transmission power for Bluetooth communications.

## Sub-Parameters

The **set bluetooth** command uses the following sub-parameter:

limited	The Bluetooth module will be discoverable to 60-seconds after the module button has been pressed.
---------	---

## Command Access

Admin level only; no access in Demo mode.

## set branch

Sets branch configuration values.

### Command Syntax

```
set branch email [disabled | enabled] <name | id | ALL>
set branch load [alarmhi | alarmlo | warnhi | warnlow] <name | id | ALL> <value>
set branch load hyst <value>
set branch snmpt [disabled | enabled] <name | id | ALL>
```

### Parameters

The **set branch** command uses the following parameters:

email	Email notifications for branch events.
hyst	Hysteresis between event state and recovery (0.0 to 10.0).
load	Current load for a branch. min=0A; max (max current) in <b>show branches</b> command; hyst=0.0-10.0A; default-1.0A.
snmpt	SNMP trap notifications for branch events.

### Sub Parameters

The **set branch** command uses the following sub-parameters:

alarmhi	High alarm value.
alarmlo	Low alarm value.
warnhi	High warning alarm.
warnlo	Low warning alarm.

### Usage Guidelines

min <= alarmlo <= warnlo <= warnhi <= alarmhi <= max

### Command Access

Admin level only

## set cord

Sets cord configuration values.

### Command Syntax

```
set cord email [disabled | enabled] <name | id | ALL>
set cord loadmax <name | id | ALL> <value>
set cord name <name | id> <name string>
set cord nomvolts <name | id | ALL> <value>
set cord outofbal [alarmhi | warnhi] <name | id | ALL> <value>
set cord outofbal hyst <value>
set cord pf [alarmlo | warnlo] <name | id | ALL> <value>
set cord pf hyst <value>
set cord snmpt [disabled | enabled] <name | id | ALL>
set cord va [alarmhi | alarmlo | warnhi | warnlo] <name | id | ALL> <value>
set cord va hyst <value>
set cord watts [alarmhi | alarmlo | warnhi | warnlo] <name | id | ALL> <value>
set cord watts hyst <value>
```

### Parameters

The **set cord** command uses the following parameters:

email	Email notifications for cord events.
hyst	Hysteresis between event state and recovery.
loadmax	Maximum current load for a cord. 1-max factory current in <b>show cords</b> command.
name	Name for the cord. 0-32 characters.
nomvolts	Nominal voltage for the cord. 0-max factory voltage in <b>show cords</b> command.
outofbal	Out-of-balance; the percent power difference between phases of a cord. min 0%, max 200%, hyst 0-10% (default 2%).
pf	Power factor. min 0.00, max 1.00, hyst 0.0-0.20 (default 0.02).
snmpt	SNMP trap notifications for cord events.
va	Power (with power factor included). min 0VA, max (power capacity) in <b>cstat</b> command, hyst 0-1000VA (default 100VA).
watts	Power (without power factor included). Min 0W, max (power capacity) in <b>cstat</b> command, hyst 0-1000W (default 100W).

### Sub-Parameters

The **set cord** command uses the following sub-parameters:

alarmhi	High alarm value.
alarmlo	Low alarm value.
warnhi	High warning alarm.
warnlo	Low warning alarm.

### Usage Guidelines

min <=alarmlo <=warnlo <=warnhi <=alarmhi <=max

### Command Access

Admin level only

## set dhcp

Sets DHCP configuration values.

### Command Syntax

```
set dhcp [disabled | enabled]
set dhcp fqdn [disabled | enabled]
set dhcp fqdn name <name>
set dhcp staticfallback [disabled | enabled]
set dhcp bootdelay [disabled | enabled]
```

### Parameters

The **set dhcp** command uses the following parameters:

fqdn	Fully-qualified domain name (FQDN).
staticfallback	Falls back to static IP address if DHCP fails. <b>Note:</b> The staticfallback option does not apply when WLAN is enabled.
bootdelay	Delays system boot by 100 seconds.

### Sub-Parameters

The **set dhcp** command uses the following sub-parameter:

name	FQDN name. 0-63 characters.
------	-----------------------------

### Command Access

Admin level only

## set dns

Sets domain name system (DNS) server configuration values.

### Command Syntax

```
set dns [primary | secondary] <ipv4/ipv6>
```

### Parameters

The **set dns** command uses the following parameters:

primary	Sets the first DNS server. 0-46 characters.
secondary	Sets the secondary DNS server. 0-46 characters.

### Command Access

Admin level only; no access in Demo mode

## set email

Sets email configuration values.

### Command Syntax

```
set email auth [disabled | enabled]
set email config [disabled | enabled]
set email [disabled | enabled]
set email event [disabled | enabled]
set email fromaddr <email addr>
set email power [disabled | enabled] See Note below.
set email smtp authtype [any | crammd5 | digestmd5 | login | plain | none]
set email smtp host <hostname>
set email smtp password <password>
set email smtp port <port>
set email smtp usefromaddr
set email smtp username <user name>
set email smtp useusername
set email test
set email toaddr1 <email addr>
set email toaddr2 <email addr>
set email trendfiles [disabled | enabled]
set email usesubjloc
set email usesubjdef
```

**Note:** The **set email power** command is for Switched products only.

### Parameters

The **set email** command uses the following parameters:

auth	Sets if authentication log messages are relayed by email
config	Sets if configuration log messages are relayed by email.
event	Sets if event log messages are relayed by email.
fromaddr	Sets the email address the messages are relayed from. 0-48 characters.
power	Sets if power log messages are relayed by email.
authtype	Sets the type of authentication to use when logging into the relay SMTP server.
host	Sets the host where the relay SMTP server is located. 0-63 characters.
password	Sets the password for logging into the relay SMTP server 0-32 characters.
port	Sets the port number for the relay SMTP server, 1-65535 (default 25).
toaddr1	Sets the first address to send email messages to. 0-48 characters.
toaddr2	Sets the second address to send email messages to. 0-48 characters.
trendfiles	Sets the preference to have new trending report files sent out daily to both "toaddr" addresses at midnight.

userfromaddr	Sets to log into the relay SMTP server using the from address.
username	Sets the username for logging into the relay SMTP server. 0-32 characters, spaces are not allowed.
test	Tests the email setting for logging into the relay SMTP.
usesubjloc	Uses the location string as the subject of the relayed emails.
usesubjdef	Uses the default subject as the subject of the relayed emails. (sentry@macoui).
useusername	Set to log into the relay SMTP server using the SMTP username.

### Sub-Parameters

The **set email** command uses the following sub-parameters:

any	Uses any of the authentication methods described in this table.
crammd5	Uses only CRAM-MD5 for authentication.
digestmd5	Uses only Digest MD5 for authentication
login	Uses only login authentication.
plain	Uses only plain authentication.
none	Uses only no authentication.

### Command Access

Admin level only; no access in Demo mode

## set energywise

Sets Cisco EnergyWise configuration values.

### Command Syntax

```
set energywise [disabled | enabled]
set energywise port <UDP port>
set energywise domain <domain name>
set energywise refresh <refresh rate>
set energywise secret <secret key>
```

### Parameters

The **set energywise** command uses the following parameters:

port	Sets the port number of the EnergyWise host. 1-65535 (default 43440).
domain	Sets the domain of the EnergyWise host. 0-63 characters.
refresh	Sets the refresh rate that sends new EnergyWise discovery packets. 30-600 seconds.
secret	Sets the secret key for the EnergyWise server. 0-80 characters.

### Command Access

Admin level only; no access in Demo mode

## set feature

Enables new system features.

### Command Syntax

```
set feature <feature key>
```

### Parameters

The **set feature** command uses the following parameter:

feature key	Key for unlocking system features (XXXX-XXXX-XXXX-XXXX), where X = 0-9 or A-Z.
-------------	--

### Command Access

Admin level only

## set ftp

Sets FTP configuration values.

### Command Syntax

```
set ftp autoupdate [disabled | enabled]
set ftp autoupdate day [sunday-saturday | everyday]
set ftp autoupdate hour [1am-12am | 1pm-12pm]
set ftp directory <path name>
set ftp filename <filename>
set ftp host <hostname>
set ftp password <password>
set ftp server [disabled | enabled]
set ftp test [full]
set ftp username <username>
```

### Parameters

The **set ftp** command uses the following parameters:

autoupdate	Sets to use automatic system firmware updates.
directory	Sets the directory of the update file in remote FTP update server. 0-64 characters.
filename	Sets the name of the update file in remote FTP update server. 0-32 characters.
host	Sets the hostname of remote FTP update server. 0-63 characters.
password	Sets the password for logging into the remote FTP update server. 0-32 characters.
server	Sets if the system can be an FTP server to serve system files.
test	Tests current FTP settings. Using the <b>full</b> sub-parameter ensures connection to the FTP server is correct, verifies firmware can be sent to the PDU, and downloads firmware to the PDU (but does not install firmware).
username	Sets the username for logging into the remote FTP update server. 0-32 characters.

### Sub-Parameters

The **set ftp** command uses the following sub-parameters:

day	Sets the day of the week to automatically update system firmware.
hour	Sets the hour of the day to automatically update system firmware.

### Command Access

Admin level only; no access in Demo mode

## set http

Sets HTTP configuration values.

### Command Syntax

```
set http [disabled | enabled]
set http port <port>
```

### Parameters

The **set http** command uses the following parameter:

port	Sets the port for HTTP connections. 1-65535 (default 443).
------	--

### Command Access

Admin level only; no access in Demo mode

## set https

Sets HTTPS configuration values.

### Command Syntax

```
set https [disabled | enabled]
set https port <port>
set https usercert [disabled | enabled]
set https userpass <passphrase>
```

### Parameters

The **set https** command uses the following parameters:

port	Sets the port for HTTPS connections. 1-65535 (default 80).
usercert	Sets to use user-provided certificates instead of system self-signed certificates.
userpass	Sets the pass phrase for user-provided certificates. 0-63 characters.

### Command Access

Admin level only; no access in Demo mode



## set ipv4, set ipv6

Sets IPv4 and IPv6 configuration values.

### Command Syntax

```
set ipv4 address <ipv4 address>
set ipv4 gateway <ipv4 address>
set ipv4 subnet <ipv4 address>
set ipv6 address <ipv6 address>
set ipv6 gateway <ipv6 address>
set ipv6 prefix <ipv6 CIDR prefix>
```

### Parameters

The **set ipv4** and **set ipv6** commands use the following parameters:

Ipv4 address	Uses the format of XXX.XXX.XXX.XXX, where XXX=0-255.
Ipv6 address	Uses the format of XXX.XXX.XXX.XXX.XXX.XXX.XXX.XXX, where XXXX=0-0xFFFF.
Ipv6 CIDR prefix	Uses the format of /0-64.

### Command Access

Admin level only; no access in Demo mode

## set ldap

Sets LDAP configuration values.

### Command Syntax

```
set ldap bind [simple | tls | md5]
set ldap binddn <distinguished name>
set ldap bindpw <password>
set ldap groupattr <group attribute>
set ldap groupsearch basedn <distinguished name>
set ldap groupsearch [disabled | enabled]
set ldap groupsearch useattr <user attribute>
set ldap primary <hostname>
set ldap secondary <hostname>
set ldap port <port>
set ldap userbasedn <distinguished name>
set ldap userfilter <filter>
```

### Parameters

The **set ldap** command uses the following parameters:

bind	Sets the bind method for the LDAP server.
binddn	Sets the distinguished name (DN) for the bind.
bindpw	Sets the password for the bind.
groupattr	Sets the user class distinguished name (DN) or names of groups a user is a member of.
groupsearch	Sets the bind to search groups for the username in addition to searching the usernames for its list of group memberships.

hostname	Sets the hostname of the Directory Services server.
port	Sets the port number for the LDAP server. 1-65535 (default 389).
userbasedn	Sets the base distinguished name (DN) for the username search at login.
userfilter	Sets the filter used for the username search at login.

#### Sub-Parameters

The **set ldap** command uses the following sub-parameters:

simple	Uses simple bind method.
tls	Uses bind with TLS. (TLS version 1).
md5	Uses Digest MD5 bind.
basedn	Base Distinguished Name (DN).
useattr	Sets the user attribute to search for.

#### Command Access

Admin level only; no access in Demo mode

## set ldapgroup

Sets configuration values for LDAP group access rights.

#### Command Syntax

```
set ldapgroup access [admin ] admin | ononly | poweruser | rebootonly | user |
viewonly] <groupname>
```

```
set ldapgroup sysmon [disabled | enabled] <groupname>
```

#### Parameters

The **set ldap group** command uses the following parameters:

access	Sets the access type of an LDAP group. <b>Note:</b> On-Only, Reboot-Only, and View-Only are available for Switched PRO2 products.
sysmon	Sets system monitor access for an LDAP group.

#### Sub-Parameters

The **set ldap group** command uses the following sub-parameter:

groupname	Name of the LDAP group to change access rights. 0-32 characters.
-----------	--

#### Command Access

Admin level only

## set line

Sets line configuration values.

### Command Syntax

```
set line email [disabled | enabled] <name | id | ALL>
set line load [alarmhi | alarmlo | warnhi | warnlo] <name | id | ALL> <value>
set line load hyst <value>
set line snmpt [disabled | enabled] <name | id | ALL>
```

### Parameters

The **set line** command uses the following parameters:

Email	Email notification for line events.
Hyst	Hysteresis between event state and recovery.
Load	Current load for a line. min = 0A, max (current limit) in <b>show lines</b> command, hyst 0.0-10.0A (default 1.0A).
SNMPT	SNMP trap notifications for line events.

### Sub-Parameters

The **set line** command uses the following sub-parameters:

alarmhi	High alarm value.
alarmlo	Low alarm value.
warnhi	High warning alarm.
warnlo	Low warning alarm.

min <= alarmlo <= warnlo <= warnhi <= alarmhi <= max

### Command Access

Admin level only

## set loadshed

Sets Smart Load Shedding configuration values.

### Command Syntax

```
set loadshed branch [disabled | enabled]
set loadshed line [disabled | enabled]
set loadshed sensor [disabled | enabled]
set loadshed sensor contact [recoveroff | recoveron] <contact sensor name | id | ALL>
set loadshed sensor temp [recoveroff | recoveron] <temp sensor name | id | ALL>
set loadshed sensor water [recoveroff | recoveron] <water sensor name | id | ALL>
set loadshed ups [all | any] <line name | id | ALL>
set loadshed ups [disabled | enabled]
set loadshed ups [recoveroff | recoveron]
set loadshed ups [recoverdelay | sheddelay] <delay>
```

## Parameters

The **set loadshed** command uses the following parameters:

branch	Sets to allow branch shedding events.
line	Sets to allow line shedding events.
sensor	Sets to allows sensor shedding events.
ups	Sets to allow UPS shedding events.

## Sub-Parameters

The **set loadshed** command uses the following sub-parameters:

all	Sheds outlets only when all UP devices on an upstream line go to “on battery”.
any	Sheds outlets when any UPS device on an upstream line goes to “on battery”.
recoverdelay	The delay that a UPS device needs to be “on utility” before recovering outlets. 0-10 minutes.
recovery off	Shed outlets are not recovered Does not recover shed outlets when even conditions are cleared.
recovery on	Automatically recover shed outlets when event conditions are cleared.
sheddelay	The delay that a UPS device needs to be “on battery” before shedding outlets. 0-10 minutes.

## Usage Guidelines

The Smart Load Shedding feature must be enabled.

## Command Access

Admin level only

## set location

Sets the system location string.

## Command Syntax

set location <location string>

## Parameters

The **set location** command uses the following parameter:

location string	Location string text for system location. 0-63 characters.
-----------------	--

## Command Access

Admin level only

## set net

Sets network mode configuration values.

### Command Syntax

```
set net [disabled | ipv4only | dualv6v4]
```

### Parameters

The **set net** command uses the following parameters:

disabled	Disables network access to system.
ipv4only	System only allows IPv4 functionality.
Dualv6v4	System allows IPv6 and IPv4 functionality.

### Command Access

Admin level only; no access in Demo mode.

## set ocp

Sets over-current protector (OCP) configuration values.

### Command Syntax

```
set ocp email [disabled | enabled] <name | id | ALL>
```

```
set ocp loadmax <name | id | ALL> <value>
```

```
set ocp snmpt [disabled | enabled] <name | id | ALL>
```

### Parameters

The **set ocp** command uses the following parameters:

email	Email notifications for OCP events.
loadmax	Maximum current load for an OCP. Valid range is 1 to “max factory current” from the <b>show ocps</b> command.
snmpt	SNMP trap notifications for OCP events.

### Command Access

Admin level only

## set outlet

Sets outlet configuration values.

### Command Syntax

```
set outlet branchevent [disabled | enabled] <name | id | ALL>
set outlet chglogging [disabled | enabled]
set outlet email [disabled | enabled] <name | id | ALL>
set outlet load [alarmhi | alarmlo | warnhi | warnlo] <name | id | ALL> <value>
set outlet load hyst <value>
set outlet name <name | id> <new name>
set outlet snmpt [disabled | enabled] <name | id | ALL>
set outlet watts [alarmhi | alarmlo | warnhi | warnlo] <name | id | ALL> <value>
set outlet watts hyst <value>
```

#### ***For Switched PRO2 products only:***

```
set outlet extondelay <name | id | ALL> <value>
set outlet host <name | id> <hostname>
set outlet lock [disabled | enabled] <name | id | ALL>
set outlet rebootdelay <value>
set outlet script [disabled | enabled] <name | id | ALL>
set outlet script delay <name | id | ALL> <value>
set outlet seqdelay <value>
set outlet shutdown [disabled | enabled] <name | id | ALL>
set outlet shutdown delay <name | id | ALL> <value>
set outlet wakeup [on | off | last] <name | id | ALL>
```

#### ***For the enabled Smart Load Shedding feature:***

```
set outlet contactevent [disabled | enabled] <name | id | ALL> <contact sensor name | id | ALL>
set outlet lineevent [disabled | enabled] <name | id | ALL>
set outlet sensoraction [off | on]
set outlet tempevent [disabled | enabled] <name | id | ALL> <temp sensor name | id | ALL>
set outlet upsevent [disabled | enabled] <name | id | ALL>
set outlet waterevent [disabled | enabled] <name | id | ALL> <water sensor name | id | ALL>
```

#### ***For AC products only:***

```
set outlet pf [alarmlo | warnlo] <name | id | ALL> <value>
set outlet pf hyst <value>
```

### Parameters

The **set outlet** command uses the following parameters:

branchevent	Sets if load shedding (due to branch events) is allowed for an outlet.
chglogging	Sets logging for system outlet state changes
contactevent	Sets if load shedding (due to contact sensor events) is allowed for an outlet.
email	Sets email notifications for outlet events.

extondelay	Sets an extra on delay when turning on an outlet. 0-900 seconds.
host	Sets the hostname for an outlet for script or shutdown actions. 0-63 characters.
hyst	Sets the hysteresis between event state and recovery.
load	Sets the current load for an outlet. min 0.0A, max (max current) in <b>show outlets</b> command, hyst 1.0-10.0A (default 1.0A)
lineevent	Sets if load shedding (due to outlet current load events) is allowed for an outlet.
lock	Sets if control actions are disabled for an outlet after wakeup state is applied.
pf	Sets the power factor. min 0.00, max 1.00, hyst 0.0-0.20 (default 0.02)
rebootdelay	Sets an extra on delay when rebooting an outlet (5-600 seconds).
script	Sets to additionally send request to have shutdown agent run a script before shutting down the host.
sensoraction	Sets the load shedding outlet control action for all sensor alarm events.
seqdelay	Sets the delay between turning on outlets. 0-15 seconds.
shutdown	Sets if notification of pending off state of outlet is sent to outlet host before changing state.
shutdown delay	Sets the remote shutdown delay for an outlet. 1-900 seconds.
snmpt	Sets if SNMP trap notifications for outlet events.
tempevent	Sets if load shedding (due to temperature sensor events) is allowed for an outlet.
upsevent	Sets if load shedding (due to UPS events) are allowed for an outlet.
wakeup	Sets the default outlet control state after system power up.
waterevent	Sets if load shedding (due to water sensor events) is allowed for an outlet
watts	Sets the power (without power factor). min 0W, max (power capacity) in <b>ostat details</b> , hyst 0-1000W (default 10W).

## Parameters

The **set outlet** command uses the following sub-parameters:

script delay	Sets the time to wait after the script has executed to outlet state change. 1-15 seconds.
shutdown delay	Sets the time to wait after the shutdown notification to host before outlet state change. Valid range is 1-900 seconds.
on	Sets outlet to sequence on after system boot.
off	Sets outlet to remain off after system boot.
last	Sets outlet to match its last state prior to system boot after system boot.
alarmhi	Sets high alarm value.
alarmlo	Sets low alarm value.
warnhi	Sets high warning value.
warnlo	Sets low warning value.

min <= alarmlo <= warnlo <= warnhi <= alarmhi <= max

## Command Access

Admin level only



## set phase

Sets phase configuration values.

### Command Syntax

```
set phase email [disabled | enabled] <name | id | ALL>  
set phase pf [alarmlo | warnlo] <name | id | ALL> <value>  
set phase snmpt [disabled | enabled] <name | id | ALL>  
set phase volts [alarmhi | alarmlo | warnhi | warnlo] <name | id | ALL> <value>  
set phase volts hyst <value>
```

#### **For AC products only:**

```
set phase pf hyst <value>
```

### Parameters

The **set phase** command uses the following parameters:

email	Sets email notifications for phase events.
hyst	Sets hysteresis between event state and recovery.
pf	Sets power factor. min 0.00, max 1.00, hyst 0.0-0.20 (default 0.02).
snmpt	Sets SNMP trap notifications for phase events.
volts	Sets voltage. min and max vary by product*, hyst 0.0-20 (default 0.02). * For the min-max range, issue <b>set cord nomvolts all</b> command (press ESC to quit command).

### Sub-Parameters

The **set phase** command uses the following sub-parameters:

alarmhi	Sets high alarm value.
alarmlo	Sets low alarm value.
warnhi	Sets high warning value.
warnlo	Sets low warning value.

### Command Access

Admin level only

## set port

Sets serial port configuration values.

### Command Syntax

```
set port [baud | speed] [1200 | 2400 | 4800 | 9600 | 19200 | 38400 | 57600 | 115200]  
<name | id >  
set port dsrcheck [disabled | enabled] <name | id >  
set port timeout <name | id > <timeout>
```

## Parameters

The **set port** command uses the following parameters:

baud/speed	Sets the number of symbols per second of the serial port.
dsrcheck	Sets to use DSR before making a serial connection.
timeout	Sets the connection idle timeout for pass-thru connections to this port. 0-60 minutes (default 5 minutes).

## Command Access

Admin level only

## set radius

Sets Radius server configuration values.

## Command Syntax

```
set radius [primary | secondary] port <port>
set radius [primary | secondary] retries <retries>
set radius [primary | secondary] host <hostname>
set radius [primary | secondary] secret <shared secret>
set radius [primary | secondary] timeout <timeout>
```

## Parameters

The **set radius** command uses the following parameters:

primary	Sets the first Radius server.
secondary	Sets the second Radius server.
port	Sets the port for Radius sever connections. 1-65535 (default 1812).
retries	Set the maximum retry count for the Radius server. 0-10 (default 2).
host	Sets the Radius server hostname. 0-63 characters.
secret	Sets the shared secret value for the Radius server. 0-48 characters. <b>Note:</b> The secret that was set for the primary server will not be cleared when setting the secret for the secondary server, and vice versa.
timeout	Sets the connection timeout for the Radius server. 1-30 seconds (default 5 seconds).

## Command Access

Admin level only; No access in Demo mode

## set sensor

Sets sensor configuration values.

### Command Syntax

```
set sensor adc [alarmhi | alarmlo | warnhi | warnlo] <name | id | ALL> <value>
set sensor adc email [disabled | enabled] <name | id | ALL>
set sensor adc hyst <value>
set sensor adc name <name | id> <name>
set sensor adc snmpt [disabled | enabled] <name | id | ALL>
set sensor contact email [disabled | enabled] <name | id | ALL>
set sensor contact name <name | id> <name>
set sensor contact snmpt [disabled | enabled] <name | id | ALL>
set sensor humid [alarmhi | alarmlo | warnhi | warnlo] <name | id | ALL> <value>
set sensor humid email [disabled | enabled] <name | id | ALL>
set sensor humid hyst <value>
set sensor humid name <name | id> <name>
set sensor humid snmpt [disabled | enabled] <name | id | ALL>
set sensor temp [alarmhi | alarmlo | warnhi | warnlo] <name | id | ALL> <value>
set sensor temp email [disabled | enabled] <name | id | ALL>
set sensor temp hyst <value>
set sensor temp name <name | id> <name>
set sensor temp snmpt [disabled | enabled] <name | id | ALL>
set sensor water email [disabled | enabled] <name | id | ALL>
set sensor water name <name | id> <name>
set sensor water snmpt [disabled | enabled] <name | id | ALL>
set sensor temp scale [celsius | fahrenheit]
```

### Parameters

The **set sensor** command uses the following parameters:

adc	Sets the analog-to-digital converter sensor. min 0, max 255, hyst 0-20 (default 1).
contact	Sets the contact closure sensor.
humid	Sets the humidity sensor. min 0%RH, max 100%RH, hyst 0-20%RH (default 2%RH).
temp	Sets temperature sensor. For Celsius: min -40°, max 123°, hyst 0-30°, default 1°; For Fahrenheit: min -40°, max 253°, hyst 0-54°, default 2°.
water	Sets the water sensor.
email	Sets the email notifications for sensor events.
hyst	Sets the hysteresis between event state and recovery.
name	Sets the name of the sensor.
snmpt	SNMP trap notifications for sensor events.
scale	Sets temperature scale.

## Sub-Parameters

The **set sensor** command uses the following sub-parameters:

alarmhi	Sets high alarm value.
alarmlo	Sets low alarm value.
warnhi	Sets high warning value.
warnlo	Sets low warning value.

min <= alarmlo <= warnlo <= warnhi <= alarmhi <= max

## Command Access

Admin level only

## set snmp

### Command Syntax

Sets SNMP configuration values.

```
set snmp iprestrict [none | trapdests]
set snmp syscontact <system contact>
set snmp syslocation <location>
set snmp sysname <system name>
set snmp trap dest1 <hostname>
set snmp trap dest2 <hostname>
set snmp trap format [v1 | v2c | v3]
set snmp trap repeat <repeat time>
set snmp v2 [disabled | enabled]
set snmp v2 [getcomm | setcomm | trapcomm] <comm string>
set snmp v3 [disabled | enabled]
set snmp v3 [roauth | rwauth] [none | md5 | md5des]
set snmp v3 [roauthpass | rwauthpass] {password} verify password}
set snmp v3 [roprivpass | rwprivpass] {password} {verify password}
set snmp v3 [rousername | rwusername | trapusername] <username>
```

### Parameters

The **set snmp** command uses the following parameters:

iprestrict	Sets to only allow to trap destinations to have SNMP access
syscontact	System contact string. 0-63 characters.
syslocation	System location string. 0-63 characters.
sysname	System name string. 0-63 characters.
trap	Sets trap notification options.
v2	Sets to allow access with SNMPv2.
v3	Sets to allow access with SNMPv3.

## Sub-Parameters

The **set snmp** command uses the following sub-parameters:

dest1	First SNMP trap destination. 0-63 characters.
dest2	Second SNMP trap destination. 0-63 characters.
format	Format of SNMP trap and header.
repeat	Sets the SNMP trap repeat time for object in an event condition. 1-65535 seconds.
getcomm	Read community string for SNMPv2. 0-32 characters. Default is public.
setcomm	Read/write community string in SNMPv3. 0-32 characters. Default is blank.
trapcomm	Community string in SNMPv2 traps for authentication. 0-32 characters.
ro-prefix	Read-Only SNMPv3 user.
rw-prefix	Read/write SNMPv3 user.
auth	Authentication type for an SNMPv3 user.
authpass	Authentication password for an SNMPv3 user. 0-39 characters.
privpass	Privacy password for an SNMPv3 user. 0-31 characters.
username	Username for an SNMPv3 user. 0-31 characters.
trapusername	Username for trap authentication for SNMPv3 traps. 0-31 characters.
none	No authentication or privacy is used (authpass and privpass are not used).
md5	Authentication but not privacy is used (privpass is not used).
md5des	Authentication and privacy are used

## Command Access

Admin level only; No access in Demo mode.

## set sntp

Sets SNTP configuration values.

### Command Syntax

```
set sntp dst [disabled | enabled]
set sntp dst [end | start] <tz string>
set sntp gmtoffset <offset>
set sntp primary <hostname>
set sntp secondary <hostname>
```

### Parameters

The **set sntp** command uses the following parameters:

dst	Sets to automatically adjust for Daylight Saving Time (DST).
gmtoffset	Sets the adjustment from Coordinated Universal Time (UTC). (-12 to 14). GMT Offset includes both extended hours and minutes.
primary	Sets the first SNTP server. 0-63 characters.
secondary	Sets the second SNTP server. 0-63 characters.

### Sub-Parameters

The **set sntp** command uses the following sub-parameters:

end	Date to end DST.
start	Date to start DST.

### Command Access

Admin level only; no access in Demo mode

## set spm

Sets Sentry Power Manager (SPM) access configuration values.

### Command Syntax

```
set spm [disabled | enabled]
set spm resetpw
```

### Parameters

The **set spm** command uses the following parameter:

resetpw	Sets to reset SPM secure password back to default.
---------	--

### Command Access

Admin level only; no access in Demo mode

## set ssh

Sets SSH configuration values.

### Command Syntax

```
set ssh [disabled | enabled]
set ssh port
set ssh authmethod [all | kbint | password]
```

### Parameters

The **set ssh** command uses the following parameters:

port	Sets port for SSH connections 1-65535 (default is 22).
authmethod	Sets authentication method for SSH connections.

### Sub-Parameters

The **set ssh** command uses the following sub-parameters:

all	Allows either of the authentication methods described in this table.
kbint	Allows only keyboard-interactive authentication.
password	Allows only password authentication.

### Command Access

Admin level only; no access in Demo mode

## set syslog

Sets Syslog configuration values.

### Command Syntax

```
set syslog debugmsg [disabled | enabled]
set syslog host1 <hostname>
set syslog host2 <hostname>
set syslog port <port>
set syslog protocol [rfc3164 | rfc5424]
```

### Parameters

The **set syslog** command uses the following parameters:

debugmsg	Sets to send debug log messages in addition to system log messages.
host1	Sets the first Syslog server. 0-63 characters.
host2	Sets the second Syslog server. 0-63 characters.
port	Sets the port for the Syslog servers. 1-65535 (default 514).
protocol	Sets the format of the Syslog messages.

### Command Access

Admin level only; no access in Demo mode

## set tacacs

Sets TACACS+ server configuration values.

### Command Syntax

```
set tacacs primary <hostname>
set tacacs secondary <hostname>
set tacacs port <port>
set tacacs key {key}
```

### Parameters

The **set tacacs** command uses the following parameters:

primary	Sets the first TACACS+ server (0-63 characters).
secondary	Sets the second TACACS+ server (0-63 characters).
port	Sets the port for the TACACS+ servers 1-65535 (default is 49).
key	Sets the key for authentication with the TACACS+ servers.

### Command Access

Admin level only; no access in Demo mode

## set tacpriv

Sets TACACS+ configuration values for privilege level access rights.

### Command Syntax

```
set tacpriv access [admin | ononly | poweruser | rebootonly | user | viewonly] <priv level>
set tacpriv sysmon [disabled | enabled] <priv level>
```

### Parameters

The **set tacpriv** command uses the following parameters:

access	Sets the access type for a level. <b>Note:</b> On-Only, Reboot-Only, and View-Only are available for Switched PRO2 products.
sysmon	Sets the system monitor access for a level.

### Sub-Parameters

The **set tacpriv** command uses the following sub-parameter:

priv level	The ID of the TACACS+ privilege level to change access rights (0-15).
------------	---

### Command Access

Admin level only



## set telnet

Sets Telnet configuration values.

### Command Syntax

```
set telnet [disabled | enabled]
set telnet port <port>
```

### Parameters

The **set telnet** command uses the following parameters:

port	Sets the port for Telnet connections 1-65535 (default is 23).
------	---

### Command Access

Admin level only; no access in Demo mode

## set trend

Sets power trending configurations.

### Command Syntax

```
set trend [disabled | enabled]
```

### Command Access

Admin level only; no access in Demo mode

## set unit

Sets PRO2 configuration values.

### Command Syntax

```
set unit assettag <name | id> <asset tag>
set unit display [auto | inverted | normal] <name | id | ALL>
set unit email [disabled | enabled] <name | id | ALL>
set unit identify [disabled | enabled] <name | id | ALL>
set unit name <name | id> <new name>
```

#### ***For Switched PRO2 products only:***

```
set unit osequence [normal | reversed] <name | id | ALL>
```

#### ***Factory unlocked only:***

```
set unit golden [disabled | enabled]
set unit prodsn <name | id> <prod sn>
```

#### ***Confirmation required:***

```
set unit purge <name | id | ALL>
set unit snmpt [disabled | enabled] <name | id | ALL>
```

### Parameters

The **set unit** command uses the following parameters:

assettag	The asset tag value of the unit. 0-32 characters.
display	Sets the orientation of the displays on a unit.
email	Email notifications for an event.
golden	Set to have the system not retain unit information.

identify	Set to enable/disable flashing display.
name	The name of the unit. 0-32 characters.
osequence	Sets the outlet sequence order for a unit.
prodsn	Sets the product serial number for a unit. 0-32 characters.
purge	Removes all stored information for a unit.
snmpt	SNMP trap notifications for unit events.

### Sub-Parameters

The **set unit** command uses the following sub-parameters:

auto	Set automatic display orientation using internal orientation sensor.
Inverted	Set display to be upside down.
normal	Set display to be right-side up; set outlet sequencing to be 1 to n.
reversed	Set outlet sequencing to be n to 1.

### Command Access

Admin level only

## set ups

Sets UPS device configuration values.

### Command Syntax

```
set ups addline <UPS#> <line name | id | ALL>
set ups commstr <UPS#> <get community string>
set ups delline <UPS#> <line name | id | ALL>
set ups host <UPS#> <hostname>
set ups oidspoll <UPS#> <oid>
set ups onbattery <UPS#> <value>
set ups onutility <UPS#> <value>
set ups port <UPS#> <port>
set ups type <UPS#> <value>
```

### Parameters

The **set ups** command uses the following parameters:

UPS#	The number of the UPS to change. 1-8.
addline	Adds the specified line to be protected by the UPS.
commstr	Sets the community string for polling the UPS by SNMP. 0-32 characters.
delline	Removes the specified line from a UPS.
host	Hostname for polling the UPS by SNMP. 0-63 characters.

oidspoll	The OID for getting the “on battery”/“on utility” value when polling the UPS by SNMP.
onbattery	Value of the OID when the UPS is in an “on battery” state. 1-65535.
onutility	Value of the OID when the UPS is in an “on utility” state. 1-65535.
port	Port number for polling the UPS by SNMP. 1-65535 (default 161).
type	Sets the type of the UPS; sets default commstr, oidspoll, onbattery, onutility, and port. 1-11.

#### Sub-Parameters

The **set ups** command uses the following sub-parameter:

oid	The OID string with sequences of a dot and a number. 1-65535.
-----	---

#### Command Access

Admin level only

#### set user

Sets configuration values for local user access rights.

#### Command Syntax

```
set user access [admin | ononly | poweruser | rebootonly | user | viewonly] <username>
set user password <username> {password} {verify password}
set user sysmon [disabled | enabled] <username>
```

#### Parameters

The **set user** command uses the following parameters:

access	Sets the access type of a local user. <b>Note:</b> On-Only, Reboot-Only, and View-Only are available for Switched PRO2 products.
password	Sets the password for a local user.
sysmon	Sets system monitor access for a local user.

#### Sub-Parameters

The **set user** command uses the following sub-parameter:

username	The ID of the local user to change access rights. 0-32 characters.
----------	--

#### Command Access

Admin level only

## set wlan

### **Description:**

Sets the wireless network configuration.

### **Command Syntax:**

```
set wlan [disabled | enabled]
set wlan bssid <ap bssid>
set wlan key <ap key>
set wlan mac <mac address>
set wlan security [open | wep-open | wep-shared | wpapsk-aes | wpapsk-tkip | wpapsk-tkipaes |
                  wpa2psk-aes | wpa2psk-tkip | wpa2psk-tkipaes]

set wlan ssid <ap ssid>
```

### **Command Access:**

Admin level only; wireless module installed.

## show access

Shows user access configuration values.

### **Command Syntax**

```
show access
```

### **Command Access**

Admin level only

### **Example**

```
Switched CDU: show access
```

#### Access Configuration

Access Method:	LDAP then local
Configuration Reset Button:	enabled
Local Administrator Account:	required
Strong Passwords:	optional
CLI Custom Prompt:	<none>
CLI Timeout:	5 minute<s>
Web Timeout:	5 minute<s>
Web Log Entries:	100 <per page>
Default Log Order:	newest first
StartUp Stick:	enabled

## show bluetooth

Shows Bluetooth® configuration values.

### Command Syntax

show bluetooth

### Command Access

Admin level only

### Example

Switched CDU: show bluetooth

```
Bluetooth Configuration
Bluetooth:          enabled
Name:              BT-Mod1
Pin code:          0000
Discoverability:   enabled
Transmission Power: 0 (dbm)
```

## show branches

Shows branch configuration values.

### Command Syntax

show branches

### Command Access

Admin level only

### Example

Switched CDU: show branches

```
ID      Branch Name
--      -
AA1     AA:Branch_1
AA2     AA:Branch_2
AA3     AA:Branch_3
BA1     BA:Branch_1
BA2     BA:Branch_2
BA3     BA:Branch_3

ID      SNMP      Email      Max      Current   Current   Current   Current
ID      Notif.     Notif.     Current  Lo-Alrm   Lo-Warn   Hi-Warn   Hi-Alrm
--      -
AA1     enabled    enabled    20A      0.0A      0.0A      14.0A     16.0A
AA2     enabled    enabled    20A      0.0A      0.0A      14.0A     16.0A
AA3     enabled    enabled    20A      0.0A      0.0A      14.0A     16.0A
BA1     enabled    enabled    20A      0.0A      0.0A      14.0A     16.0A
BA2     enabled    enabled    20A      0.0A      0.0A      14.0A     16.0A
BA3     enabled    enabled    20A      0.0A      0.0A      14.0A     16.0A

Common Branch Settings
Branch Current Hysteresis:      1.0A
```

## show cords

Shows cord configuration values.

### Command Syntax

```
show cords
```

### Command Access

Admin level only

### Example

```
Switched CDU: show cords
```

```
ID      Cord Name
--      -
AA      Master_Cord_A
BA      Link_Cord_A

      SNMP      Email      User / Factory      User / Factory
ID      Notif.      Notif.      Current Capacity    Nominal Voltage
--      -
AA      enabled    enabled    30A / 30A           230V / 230V
BA      enabled    enabled    30A / 30A           230V / 230V

      Power      Power      Power      Power      Balance      Balance
ID      Lo-Alarm    Lo-Warn    Hi-Warn    Hi-Alarm    Hi-Warn      Hi-Alarm
--      -
AA      0W          0W          14490W     16560W     15%          20%
BA      0W          0W          14490W     16560W     15%          20%

      App Pwr    App Pwr    App Pwr    App Pwr    PF           PF
ID      Lo-Alarm    Lo-Warn    Hi-Warn    Hi-Alarm    Lo-Alarm     Lo-Warn
--      -
AA      0VA         0VA         14490VA    16560VA    0.70         0.80
BA      0VA         0VA         14490VA    16560VA    0.70         0.80
```

```
Common Cord Settings
```

```
Cord Power Hysteresis:           100
Cord Apparent Power Hysteresis:   100
Cord Power Factor Hysteresis:     0.0
Cord 3-Phase Out-Of-Balance Hyst: 2%
```

## show email

Shows email configuration values.

### Command Syntax

show email

### Command Access

Admin level only

### Example

```
Switched CDU: show email
Email/SMTP Configuration
SMTP Host:          (not set)
SMTP Port:          25
SMTP Authentication: None with SMTP Username
SMTP Username:
SMTP Password:      (not set)
'From' Addr:
'To' Address 1:
'To' Address 2:
Subject ID:         [Sentry_60000a]

Email Notifications: disabled
EVENT Messages:    enabled
AUTH Messages:     disabled
POWER Messages:    disabled
CONFIG Messages:   disabled
Trend Files:       disabled
```

## show energywise

Shows Cisco EnergyWise configuration values.

### Command Syntax

show energywise

### Command Access

Admin level only

### Example

```
Switched CDU: show energywise
EnergyWise Configuration
EnergyWise Endpoint: disabled
Port:                 43440
Domain:                (not set)
Refresh Rate:         180
Secret:                (not set)
```

## show features

Shows the enabled system features.

### Command Syntax

```
show features
```

### Command Access

Admin level only

### Example

```
Switched CDU: show features
Add-on features installed on this system:
  Smart Load Shedding
```

## show ftp

Shows FTP configuration values.

### Command Syntax

```
show ftp
```

### Command Access

Admin level only

### Example

```
Switched CDU: show ftp
FTP Client Configuration
Host:          10.1.2.230
Username:      swcd8
Password:      <not set>
Directory:
Filename:      firmware.bin

Auto Upgrades: disabled
Update Day:    Everyday
Update Hour    12 AM

FTP Server Configuration
Server:        enabled
```



## show ldap

Shows LDAP configuration values.

### Command Syntax

```
show ldap
```

### Command Access

Admin level only

### Example

```
Switched CDU: show ldap
```

#### LDAP Configuration

```
LDAP:                disabled
Primary Host:        <not set>
Secondary Host:      <not set>
Port:                389
Bind Type:           Simple
```

#### Search Bind

```
DN:
Password:            <not set>
```

#### User Search

```
Base DN:
Filter:
```

#### Group Membership

```
Attribute:
```

```
Group Search:        disabled
```

```
Base DN:
User Member
Attribute:
```

## show lines

Shows line configuration values.

### Command Syntax

```
show lines
```

### Command Access

Admin level only

### Example

```
Switched CDU: show lines
```

```
ID      Line Name
--      -
AA1     AA:L1
CA1     CA:L1
DA1     DA:L1

          SNMP      Email      Max      Current  Current  Current  Current
ID      Notif.      Notif.      Current  Lo-Alarm Lo-Warn  Hi-Warn  Hi-Alarm
--      -
AA1     enabled      enabled      30A      0.0A     0.0A     21.0A     24.0A
CA1     enabled      enabled      30A      0.0A     0.0A     21.0A     24.0A
DA1     enabled      enabled      30A      0.0A     0.0A     21.0A     24.0A

Common Line Settings

Line Current Hysteresis:      1.0A
```

## show loadshed

Shows load shedding configuration values.

### Command Syntax

show loadshed

### Command Access

Admin level only

### Example

Switched CDU: show loadshed

General load shedding options:	Status	Action Delay
UPS On-Battery Load Shedding:	disabled	0 minute(s)
UPS On-Utility Auto Recovery:	enabled	0 minute(s)
Line Load Shedding:	disabled	
Branch Load Shedding:	disabled	
Sensor Load Shedding:	disabled	

Line shedding event settings:

ID	Line Name	On-Bat Shed	High Current
--	-----	-----	-----
AA1	AA:L1	disabled	24.0A
BA1	BA:L1	disabled	24.0A

Sensor shedding event settings:

ID	Sensor Name	Type	Auto-Rec	High Temp
--	-----	----	-----	-----
E1	Contact_Sensor_E1	CS	disabled	--
E2	Contact_Sensor_E2	CS	disabled	--
E3	Contact_Sensor_E3	CS	disabled	--
E4	Contact_Sensor_E4	CS	disabled	--
A1	Temp_Sensor_A1	TS	disabled	50C
A2	Temp_Sensor_A2	TS	disabled	50C
B1	Temp_Sensor_B1	TS	disabled	50C
B2	Temp_Sensor_B2	TS	disabled	50C
E1	Temp_Sensor_E1	TS	disabled	50C
E2	Temp_Sensor_E2	TS	disabled	15C
E1	Water_Sensor_E1	WS	disabled	--

Outlet load shedding events:

-Enabled Load-Shed Events-				
ID	Outlet Name	UPS	Line	Branch
AA1	Master_Outlet_1	-	-	-
AA2	Master_Outlet_2	-	-	-
AA3	Master_Outlet_3	-	-	-
AA4	Master_Outlet_4	-	-	-
AA5	Master_Outlet_5	-	-	-

## show log

Shows the system event log.

### Command Syntax

```
show log [filter]
```

### Parameters

The **show log** command uses the following parameter:

filter	Keyword filter for long entries.
--------	----------------------------------

### Command Access

Admin level only

### Example

```
Switched CDU: show log
```

```
There are 8 messages in the system log (#1-#8)
```

```
[1] L6 EVENT: Network stack started
```

```
[2] L6 EVENT: System boot complete
```

```
[3] L2 EVENT: High alarm (temperature 22.9C) detected on temperature sensor 'Temp_Sensor_C2' [C2]
```

```
[4] L5 EVENT: Normal temperature restored on temperature sensor 'Temp_Sensor_C2' [C2]
```

```
[5] May 5 13:54:56 L2 EVENT: High alarm (power 1W) detected on outlet 'Master_Outlet_30' [AA30]
```

```
[6] May 5 13:54:56 L2 EVENT: Low alarm (power factor 0.03) detected on outlet 'Master_Outlet_30' [AA30]
```

```
[7] May 5 13:54:56 L5 EVENT: Normal power factor restored on outlet 'Master_Outlet_30' [AA30]
```

```
[8] May 5 14:38:34 L6 AUTH: User 'admn' logged in from 10.1.7.30 using TELNET
```

## show network

Shows network configuration values.

### Command Syntax

show network

### Command Access

Admin level only

### Example

Switched CDU: show network

#### Network Configuration

```
State:          Static IPv4      Network:        IPv4 only
Link:           Up              Negotiation:    Auto
Speed:          100 Mbps        Duplex:         Full
Ethernet MAC:   00-0A-9C-60-00-0A
AutoCfg IPv6:   FE80::20A:9CFF:FE60:A/64
IPv4 Address:   10.1.2.205          Subnet Mask:    255.255.0.0
IPv4 Gateway:   10.1.1.1
DNS1:           10.1.5.133
DNS2:           10.1.5.134
```

#### Static IPv4/IPv6 Settings

```
IPv6 Address:   FD01::A01:305/64
IPv6 Gateway:   FD01::A01:585
IPv4 Address:   10.1.2.205          Subnet Mask:    255.255.0.0
IPv4 Gateway:   10.1.1.1
DNS1:           10.1.5.133
DNS2:           10.1.5.134
```

#### DHCP Settings

```
DHCP:           disabled
FQDN:           enabled [sentry-ffffff]
Boot Delay:     disabled
Static Fallback: enabled
```

#### Network Services

```
FTP Server:     enabled      Port:      21
FTP Updates:    disabled     Port:      21
SSH:            enabled      Port:      22      Auth:      Password, Kb-Int
Telnet:         enabled      Port:      23
HTTP:           enabled      Port:      80
HTTPS:          enabled      Port:      443     Installed Cert: Factory
User Cert:      enabled

SSL User Certificates: enabled
User Passphrase: <none>
Uploaded Files: None

SNMPv1/2:       enabled      Port:      161     TrapPort: 162
SNMPv3:         disabled     Port:      161     TrapPort: 162
SPM Access:     enabled
```

## show ocps

Shows over-current protection (OCP) configuration values.

### Command Syntax

```
show ocps
```

### Command Access

Admin level only

### Example

```
Switched CDU: show ocps
```

ID	Over-Current Protector Name	SNMP Notif.	Email Notif.	User Current	Factory Capacity
AA1	AA:Breaker_1	enabled	enabled	20A	/ 20A
AA2	AA:Breaker_2	enabled	enabled	20A	/ 20A
AA3	AA:Breaker_3	enabled	enabled	20A	/ 20A

## show outlets

Shows outlet configuration values.

### Command Syntax

show outlets

### Command Access

Admin level only

### Example

Switched CDU: show outlets

ID	Outlet Name				SNMP Notif.	Email Notif.	Max Current
AA1	Master_Outlet_1				enabled	enabled	20A
AA2	Master_Outlet_2				enabled	enabled	15A
AA3	Master_Outlet_3				enabled	enabled	15A

ID	Extra On Delay	Wakeup State	Locked No-Ctl		PF Lo-Alarm	PF Lo-Warn
AA1	0 sec	On	No		0.70	0.80
AA2	0 sec	On	No		0.70	0.80
AA3	0 sec	On	No		0.70	0.80

ID	Current Lo-Alarm	Current Lo-Warn	Current Hi-Warn	Current Hi-Alarm	Power Lo-Alarm	Power Lo-Warn	Power Hi-Warn	Power Hi-Alarm
AA1	0.0A	0.0A	14.0A	16.0A	0W	0W	2912W	3328W
AA2	0.0A	0.0A	10.5A	12.0A	0W	0W	2184W	2496W
AA3	0.0A	0.0A	10.5A	12.0A	0W	0W	2184W	2496W

Common Outlet Settings

Sequence Delay: 2 second(s)  
Reboot Delay: 15 second(s)  
Outlet State Change Logging: disabled  
Outlet Current Hysteresis: 1.0A  
Outlet Power Hysteresis: 10W  
Outlet Power Factor Hysteresis: 0.02

## show phases

Shows phase configuration values.

### Command Syntax

show phases

### Command Access

Admin level only

### Example

Switched CDU: show phases

```
ID      Phase Name
--      -
AA1     AA:L1-L2
AA2     AA:L2-L3
AA3     AA:L3-L1

          SNMP      Email      Nominal
ID      Notif.      Notif.      Voltage
--      -
AA1     enabled      enabled      208V
AA2     enabled      enabled      208V
AA3     enabled      enabled      208V

          Voltage  Voltage  Voltage  Voltage  PF      PF
ID      Lo-Alarm  Lo-Warn  Hi-Warn  Hi-Alarm  Lo-Alarm  Lo-Warn
--      -
AA1     187.2V    197.6V   218.4V   228.8V    --      --
AA2     187.2V    197.6V   218.4V   228.8V    --      --
AA3     187.2V    197.6V   218.4V   228.8V    --      --

Common Phase Settings

Phase Voltage Hysteresis:      2.0V
Phase Power Factor Hysteresis: 0.02
```

## show ports

Shows port configuration values.

### Command Syntax

show ports

### Command Access

Admin level only

### Example

Switched CDU: show ports

```
ID      Port Name      Locked      Baud      Timeout      DSR Chk
--      -
COM1    Console         No          9600      5 min        enabled
COM2    Aux             No          115200    5 min        enabled
```



## show radius

Shows Radius server configuration values.

### Command Syntax

```
show radius
```

### Command Access

Admin level only

### Example

```
Switched CDU: show radius
RADIUS Configuration
RADIUS:          disabled

Primary
Server:          (not set)
Shared Secret:  (not set)
Port:            1812
Timeout:         5 second(s)
Retries:         2

Secondary
Server:          (not set)
Shared Secret:  (not set)
Port:            1812
Timeout:         5 second(s)
Retries:         2
```

## show sensors

Shows sensor configuration values.

### Command Syntax

```
show sensors
```

### Command Access

Admin level only

### Example

```
Switched CDU: show sensors
```

```
Sensor ID Sensor Name
----- --
Temp A1 Temp_Sensor_A1
Temp A2 Temp_Sensor_A2
Temp C1 Temp_Sensor_C1
Temp C2 Temp_Sensor_C2
Humid A1 Humid_Sensor_A1
Humid A2 Humid_Sensor_A2
Humid C1 Humid_Sensor_C1
Humid C2 Humid_Sensor_C2
Contact C1 Contact_Sensor_C1
Contact C2 Contact_Sensor_C2
Contact C3 Contact_Sensor_C3
Contact C4 Contact_Sensor_C4
Water C1 Water_Sensor_C1
ADC C1 ADC_Sensor_C1
```

Sensor	ID	SNMP Notif.	Email Notif.	Lo-Alrm	Lo-Warn	Hi-Warn	Hi-Alrm
Temp	A1	enabled	enabled	1C	5C	45C	50C
Temp	A2	enabled	enabled	1C	5C	45C	50C
Temp	C1	enabled	enabled	1C	5C	45C	50C
Temp	C2	enabled	enabled	1C	5C	45C	50C
Humid	A1	enabled	enabled	5% RH	10% RH	90% RH	95% RH
Humid	A2	enabled	enabled	5% RH	10% RH	90% RH	95% RH
Humid	C1	enabled	enabled	5% RH	10% RH	90% RH	95% RH
Humid	C2	enabled	enabled	5% RH	10% RH	90% RH	95% RH
Contact	C1	enabled	enabled	--	--	--	--
Contact	C2	enabled	enabled	--	--	--	--
Contact	C3	enabled	enabled	--	--	--	--
Contact	C4	enabled	enabled	--	--	--	--
Water	C1	enabled	enabled	--	--	--	--
ADC	C1	disabled	disabled	0	0	255	255

```
Common Sensor Settings
```

```
Temperature Scale: Celsius
Temperature Sensor Hysteresis: 1C
Humidity Sensor Hysteresis: 2% RH
ADC Sensor Hysteresis: 1
```

## show shutdown

Shows outlet shutdown configuration values.

### Command Syntax

show shutdown

### Usage Guidelines

This command is for Switched products only.

### Command Access

Admin level only

### Example

Switched CDU: show shutdown

ID	Outlet Name	Shutdown/Delay	Script/Delay
AA1	Master_Outlet_1	Off / 90 sec	Off / 1 min
AA2	Master_Outlet_2	Off / 90 sec	Off / 1 min
AA3	Master_Outlet_3	Off / 90 sec	Off / 1 min
AA4	Master_Outlet_4	Off / 90 sec	Off / 1 min
AA5	Master_Outlet_5	Off / 90 sec	Off / 1 min
AA6	Master_Outlet_6	Off / 90 sec	Off / 1 min

ID	Outlet Hostname/IP
AA1	(not set)
AA2	(not set)
AA3	(not set)
AA4	(not set)
AA5	(not set)
AA6	(not set)

## show snmp

Shows SNMP configuration values.

### Command Syntax

```
show snmp
```

### Command Access

Admin level only

### Example

```
Switched CDU: show snmp
```

```
SNMP Configuration
```

```
SNMPv2 Agent:          enabled
```

```
  Get Community <RO>:  public
```

```
  Set Community <RW>:
```

```
SNMPv3 Agent:          disabled
```

```
  Engine ID:           8000006B602
```

```
  RW User Name:         <not set>
```

```
  RW User Auth Method:  none
```

```
  RW User Auth Password: <not set>
```

```
  RW User Privacy Pass: <not set>
```

```
  RO User Name:         <not set>
```

```
  RO User Auth Method:  none
```

```
  RO User Auth Password: <not set>
```

```
  RO User Privacy Pass: <not set>
```

```
SNMP Trap:
```

```
  Format:                v1
```

```
  v2 Community:         trap
```

```
  v3 Username:          <not set>
```

```
  Destination 1:
```

```
  Destination 2:
```

```
  IP Restrictions:      No Restrictions
```

```
  Error Repeat Time:    60 second(s)
```

```
SNMP SysName:          Sentry_60000a
```

```
SNMP SysLocation:      FIRMWARE PIPS-POPS Switched 3P
```

```
SNMP SysContact:
```

## show sntp

Shows SNTP configuration values.

### Command Syntax

```
show sntp
```

### Command Access

Admin level only

### Example

```
Switched CDU: show sntp
```

```
SNTP Configuration
```

```
Local Date/Time:      2014-05-06 14:30:41 (DST)
Primary Host:         2.servertech.pool.ntp.org
Secondary Host:       1.servertech.pool.ntp.org
Local GMT Offset:     -8:00 hours

Daylight Saving Time: enabled
DST Start:            2nd Sunday in March at 02:00:00
DST End:              1st Sunday in November at 02:00:00
```

## show syslog

Shows Syslog configuration values.

### Command Syntax

```
show syslog
```

### Command Access

Admin level only

### Example

```
Switched CDU: show syslog
```

```
SYSLOG Configuration
```

```
Host 1:               <not set>
Host 2:               <not set>
Port:                 514
Protocol:             RFC3164
Debug Messaging:     disabled
```

## show system

Shows system uptime, firmware version, firmware build information, boot version, hardware version, number of active users, and location string.

### Command Syntax

```
show system
```

### Command Access

Admin level only

### Example

```
Switched CDU: show system

System Information

Uptime:      1 day 20 hours 0 minutes 13 seconds
Firmware:    Sentry Switched CDU Version 8.0a
Build Info:  Rev 1032, January 7 2015, 10:52:42
Boot Info:   4.0d-r139
Hardware:    NIM2-1L (129), 75 MHz, 16MB RAM, 4MB FLASH
NIC S/N:     9600165
Active Users: 1

Location:    PIPS-POPS Switched
```

## show tacacs

Shows TACACS+ configuration values.

### Command Syntax

```
show tacacs
```

### Command Access

Admin level only

### Example

```
Switched CDU: show tacacs

TACACS+ Configuration

TACACS+:      disabled
Primary Host: <not set>
Secondary Host: <not set>
Port:         49
Key:          <not set>
```

## show trend

Shows power trending configurations.

### Command Syntax

```
show trend
```

### Command Access

Admin level only

### Example

```
Switched CDU: show trend

Trending Configuration

Data Trending:  enabled
```

## show units

Shows CDU configuration values.

### Command Syntax

```
show units
```

### Command Access

Admin level only

### Example

```
Switched CDU: show units

Unit Name:      Master <A>
Type:           Master
Model Number:   STV-6503K
Product S/N:    STVU0000118
Asset Tag:      testtaglasdf
Display Orient: Auto <Normal>
Outlet Sequence: Normal
SNMP Notif.:   enabled
Email Notif.:  enabled

Unit Name:      Link <B>
Type:           Link
Model Number:   SEV-4503K
Product S/N:    <not set>
Asset Tag:      AGHWERAfSasdf
Display Orient: Auto <Normal>
Outlet Sequence: Normal
SNMP Notif.:   enabled
Email Notif:   enabled
```

## show ups

Shows UPS device configuration values.

### Command Syntax

```
show ups
```

### Command Access

Admin level only

### Example

```
Switched CDU: show ups

UPS #1:          Generic RFC1628

SNMP Host/IP:    (not set)
SNMP Port:       161
SNMP Get Community: public
SNMP Status OID: .1.3.6.1.2.1.33.1.4.1.0
SNMP On Utility Val: 0x3
SNMP On Battery Val: 0x5
Line List:
```

## show waps

**Description:**

Displays the available wireless access points.

**Command Syntax:**

```
show waps
```

**Command Access:**

Admin level only; wireless module installed.

## show wlan

**Description:**

Displays the wireless network configurations.

**Command Syntax:**

```
show wlan
```

**Command Access:**

Admin level only; wireless module installed.



## shutdown

Turns off a specified outlet or outlet group after performing a user-specified shutdown operation.

### Command Syntax

```
shutdown <name | id | group | ALL>
```

### Usage Guidelines

For Switched CDU products only.

### Command Access

Admin and Power User

### Example

```
Switched CDU: shutdown
    Outlet name or ID, group name or ALL:
```

## status

Displays the latest status and control state for a specified outlet or outlet group.

### Command Syntax

```
status <name | id | group | ALL>
```

### Usage Guidelines

### Command Access

Any access level

### Example

```
Switched CDU: status all

  ID      Outlet Name      Control State  State  Status
  --      -
  AA1     Master_Outlet_1      Idle On       On     Normal
  AA2     Master_Outlet_2      Idle On       On     Normal
  AA3     Master_Outlet_3      Idle On       On     Normal
  AA4     Master_Outlet_4      Idle On       On     Normal
  AA5     Master_Outlet_5      Idle On       On     Normal
  AA6     Master_Outlet_6      Idle On       On     Normal
```

## sysstat

Displays the count of all system objects (by type), the latest status of the objects, and the count of objects currently in an event condition.

### Command Syntax

```
sysstat
```

### Command Access

System Monitor access

### Example

```
Switched CDU: sysstat
```

Qty	Sub-System	Status	Events
---	-----	-----	-----
2	Units	Normal	0
1	Cords	Normal	0
3	Lines	Normal	0
3	Phases	Normal	0
3	OCPs	Normal	0
3	Branches	Normal	0
30	Outlets	Normal	0
14	Sensors	Normal	0
1	UPS	Normal	0

## upsstat

Displays the latest status and metrics for all UPS devices in the system.

### Command Syntax

```
upsstat
```

### Command Access

System Monitor access

### Example

```
Switched CDU: upsstat
```

ID	UPS Type	Status
--	-----	-----
1	Generic RFC1628	Not Found

## ustat

Displays the latest status and metrics for all CDUs in the system.

### Command Syntax

ustat

### Command Access

System Monitor access

### Example

```
Switched CDU: ustat
  ID      Unit Name          Type   Status
  --      -
  A       Master             Master Normal
  ID      Display Orientation
  --      -
  A       Auto <Inverted>
```

## version

Displays the current firmware version.

### Command Syntax

version

### Command Access

Any access level

### Example

```
Switched CDU: version
Sentry Switched CDU Version 8.0
```

## Appendix A: Product Support Information

### LED Indicators

The following input current LED indicators can be displayed on the Switched PRO2 products:

Behavior/Indicator	Description	Comments/User Action
"--" (flashing double dashes)	Occurs during normal boots, restarts, and firmware flash updates but should revert to displaying amperage values upon completion. Internal communication bus error is indicated if behavior is endless.	If the behavior is endless, contact Server Technology Technical Support at: 1-800-835-1515 or <a href="mailto:support@servertech.com">support@servertech.com</a>
(flashing amperage value)	The current exceeds user-defined "high load" threshold (default setting is 80% of maximum input feed capacity).	Unit blinks a half-second on, half-second off.
"bE"	Breaker Error. The PDU has detected an error with the circuit-breakered Branch Circuit Protection.	Display alternates between showing amperage value for two seconds and flashing "bE" three times. Check to see if the breaker was tripped.
"FE"	Fuse Error. The PDU has detected an error with the fused Branch Circuit Protection.	Display alternates between showing amperage value for two seconds and flashing "FE" three times. Check to see if the fuse was blown or removed.
"oL" (flashing)	Overload.	Current exceeds the input feed capacity.
"UA", "Ub", "UC", "Ud"	Occurs when you select the <b>Configuration &gt; Units &gt; Identify</b> option.	Not an error code; no user action required. Display alternates between showing amperage value for two seconds and flashing "UA", "Ub", "UC", or "Ud" three times.  If unit is a master, "UA" (unit A) flashes.  If unit is one of up-to-three possible link types, these indicators flash: "Ub" (unit B), "UC" (unit C), or "Ud" (unit D).

## Branch Circuit Protection

Server Technology PDUs are equipped with one of several types of Branch Circuit Protection, including internal fuses, retractable fuse holders, and circuit breakers, as illustrated below.

These fuses and circuit breakers meet the strict safety requirements of UL 60950-1 and EN 60950-1 for Branch Circuit Protection.

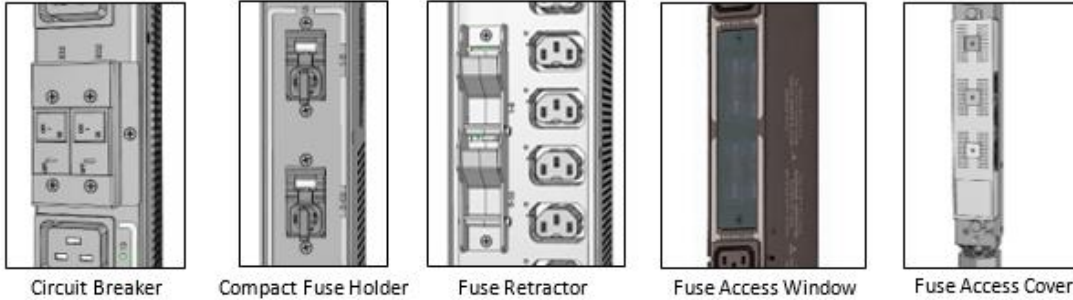

## Circuit Breaker

If a circuit breaker is tripped, it can be reset by pressing or switching it back ON once the cause of the overload or short circuit has been identified, removed, or resolved. Intelligent PDUs with branch circuit sensing will display a flashing *FE* on the input current LED(s) to indicate *Fuse Error*.

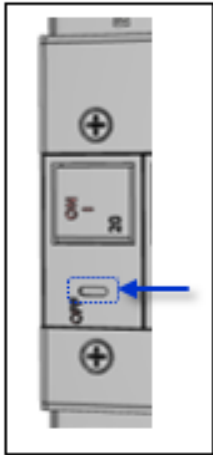

Alternatively, the circuit breaker can be turned OFF manually by inserting a slotted or flat-blade tool into the OFF switch as shown in the illustration on the left.

It is not necessary to disconnect the AC power source to perform this operation.

**NOTE:** This circuit breaker contains no user-serviceable parts. Do not open or disassemble this part.

## Compact Fuse Holder

The Compact Fuse Holder is a UL 98 listed Fused Disconnect Switch that allows the user to turn OFF the branch circuit and safely service the fuse without having to disconnect the PDU AC power source prior to performing this operation.

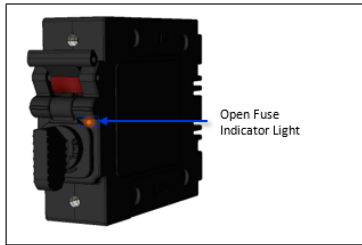

To help identify which fuse is open, blown, or missing, the Open Fuse Indicator Light glows **orange** when the PDU is powered and the Switch Handle is in the ON position.

Additionally, intelligent PDUs with branch circuit sensing will display a flashing *FE* on the input current LEDs to indicate *Fuse Error*.

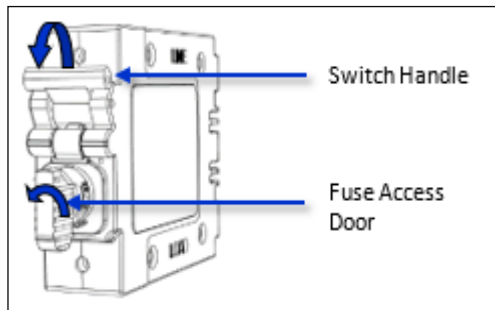

To service the fuse or turn OFF the branch, rotate the Switch Handle toward the Fuse Access Door.

Next, rotate the Fuse Access Door counter clock-wise until it opens.

Only replace the fuse with the same size, type, and ratings as the original fuse.

Reverse these steps after the new fuse(s) is installed.

---

### CAUTION:

- Failure to replace the fuse with the same size, type, and ratings will damage the PDU and the connected and nearby equipment, and will cause electrical shock, fire, explosion, or injury/death.
  - Do not attempt to open the Fuse Access Door without first setting the Switch Handle in the OFF position. Forcibly rotating the Fuse Access Door will damage the fused holder.
-

## Fuse Retractor, Fuse Access Window, and Fuse Access Cover



**The PDU AC power source must be disconnected prior to servicing a unit with the Fuse Retractor, Fuse Access Window, and Fuse Access Cover.**

Intelligent PDUs with branch circuit sensing will display a flashing *FE* on the input current LEDs to indicate *Fault Error*.

For the fuse retractor, rotate the fuse holder exposing the fuse.

For the fuse access window or cover, remove the screws that secure the plastic cover.

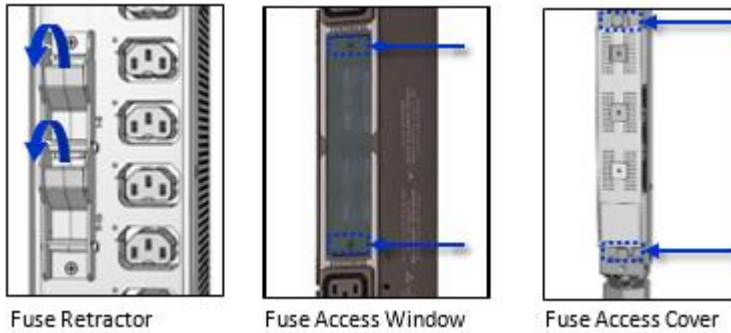

Once the fuses are exposed, carefully remove and replace with a new one of the same size, type, and ratings as the original. A fuse puller may be needed for fuse access windows and covers.

Reverse these steps after the new fuse(s) is installed.

---

### CAUTION:

- Failure to replace the fuse with the same size, type, and ratings will damage the PDU and the connected and nearby equipment, and will cause electrical shock, fire, explosion, or injury/death.
-

## Time-Delay Fuses – Class G

**NOTE:** Server Technology PDUs ship with Bussman SC-20 fuses.

Ampere Rating	Voltage	Interrupting Rating	Bussman Part No.*	Server Technology Part No.
20 A	600 Vac	100,000 A RMS Sym. AC	SC-20	FUSE-SC20G

\* Cooper Bussman Technical Data Sheet 1024

For technical support or service with time-delay fuses, contact Server Technology as follows:



### Experience Server Technology's FREE Technical Support

Server Technology understands that there are often questions when installing and/or using a new product. Free Technical Support is provided from 8 a.m. to 5 p.m. PST, Monday through Friday. After-hours service is provided to ensure your requests are handled quickly no matter what time zone or country you are located in.

Server Technology, Inc.

1040 Sandhill Drive

Tel: 1-800-835-1515

Web: [www.servertech.com](http://www.servertech.com)

Reno, Nevada 89521 USA

Fax: 775-284-2065

Email: [support@servertech.com](mailto:support@servertech.com)



## PROx Network Interface Card (NIC) Swap

The NIC in your PROx PDU is a hot-swappable assembly that can be removed and installed without the loss of output voltage, as described in the following instructions:

1. Remove the Phillips-head retention screws and save for step 4.

**Note:** Some models have either one or two screws, shown in the following two images:



2. Using equal pressure on both sides, pull the NIC out of the PDU enclosure.
3. Install the new NIC, ensuring the NIC is orientated so that it lines up with the connector inside of the PDU enclosure, as illustrated below.

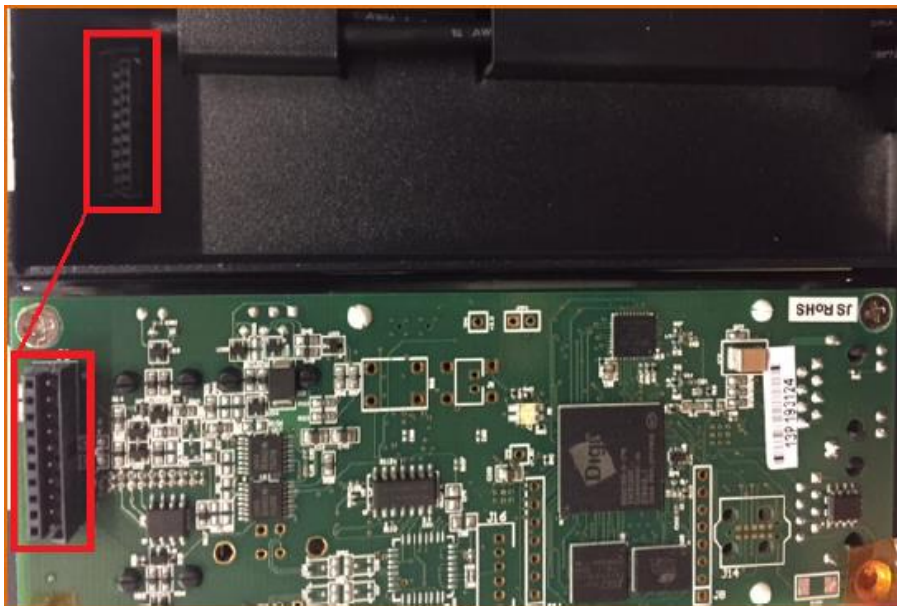

4. Install the Phillips-head retention screws.

# Appendix B: Regulatory Compliance

## Product Safety

Units have been safety tested and certified to the following standards:

- USA/Canada UL 60950-1:2007 and CAN/CSA 22.2 No. 60950-1-07
- European Union EN 60950-1:2006 + A11 + A1 + A12

This product is also designed for Norwegian IT power system with phase-to phase voltage 230V.

## Notifications

### USA Notification

Note: This equipment has been tested and found to comply with the limits for a Class A digital device, pursuant to part 15 of the FCC Rules. These limits are designed to provide reasonable protection against harmful interference when the equipment is operated in a commercial environment. This equipment generates, uses, and can radiate radio frequency energy and, if not installed and used in accordance with the instruction manual, may cause harmful interference to radio communications. Operation of this equipment in a residential area is likely to cause harmful interference in which case the user will be required to correct the interference at the user's own expense.

Modifications not expressly approved by the manufacturer could void the user's authority to operate the equipment under FCC rules.

### Canadian Notification

This Class A digital apparatus complies meets all requirements of the Canadian Interference-Causing Equipment Regulations.

Cet appareil numérique de la classe A respecte toutes les exigences du Règlement sur le matériel brouilleur du Canada.

### European Union Notification

Products with the CE Marking comply with both the EMC Directive (89/336/EEC) and the Low Voltage Directive (73/23/EEC) issued by the Commission of the European Community.

Compliance with these directives implies conformity to the following European Norms:

- EN55022 Electromagnetic Interference
- EN55024 Electromagnetic Immunity
- EN60950-1 Product Safety



- EN61000-3 Harmonics and Flicker

Products with the following mark comply with the RoHS Directive (2002/95/EC) issued by the Commission of the European Community.

## Japanese Notification

この装置は、情報処理装置等電波障害自主規制協議会（VCCI）の基準に基づくクラスA情報技術装置です。この装置を家庭環境で使用すると電波妨害を引き起こすことがあります。この場合には使用者が適切な対策を講ずるよう要求されることがあります。

本製品に同梱または付属しております電源コードは、本製品専用です。本製品以外の製品ならびに他の用途に使用しないで下さい。

## Chinese Notification

关于符合中国《电子信息产品污染控制管理办法》的声明

产品中有毒有害物质的名称及含量

部件名称 (Parts)	有毒有害物质或元素 (Hazardous Substance)					
	铅 (Pb)	汞 (Hg)	镉 (Cd)	六价铬 (Cr (VI))	多溴联苯 (PBB)	多溴二苯醚 (PBDE)
机箱子组件 (Chassis Subassembly)	O	O	O	O	O	O
印刷板组件 (PCAs)	X	O	O	O	O	O

O 表示该有毒有害物质在该部件所有均质材料中的含量均在SJ/T 11363-2006 标准规定的限量要求以下。  
Indicates that this hazardous substance contained in all homogeneous materials of this part is below the limit requirement in SJ/T 11363-2006.

X 表示该有毒有害物质至少在该部件的某一均质材料中的含量超出SJ/T 11363-2006 标准 规定的限量要求。  
Indicates that this hazardous substance contained in at least one of the homogeneous materials of this part is above the limit requirement in SJ/T 11363-2006.

## Product Recycling

### Recycling



Server Technology Inc. encourages the recycling of its products. Disposal facilities, environmental conditions and regulations vary across local, state and country jurisdictions, so Server Technology encourages consultation with qualified professional and applicable regulations and authorities within your region to ensure proper disposal.

### Waste Electrical and Electronic Equipment (WEEE)



In the European Union, this label indicates that this product should not be disposed of with household waste. It should be deposited at an appropriate facility to enable recovery and recycling.

## Appendix C: Product Warranty–Technical Support–RMA

### Warranty

For Server Technology warranty information, visit our website: [www.servertech.com](http://www.servertech.com)

### Contact Technical Support



#### Experience Server Technology's FREE Technical Support

Server Technology understands that there are often questions when installing and/or using a new product. Free Technical Support is provided from 8 a.m. to 5 p.m. PST, Monday through Friday. After-hours service is provided to ensure your requests are handled quickly no matter what time zone or country you are located in.

Server Technology, Inc.

1040 Sandhill Drive

Tel: 1-800-835-1515

Web: [www.servertech.com](http://www.servertech.com)

Reno, Nevada 89521 USA

Fax: 775-284-2065

Email: [support@servertech.com](mailto:support@servertech.com)

### Return Merchandise Authorization (RMA)

If you have a product that is not functioning properly and needs technical assistance or repair, see the Server Technology **Return Merchandise Authorization** process at: [www.servertech.com](http://www.servertech.com)





## Server Technology®

HEADQUARTERS -  
NORTH AMERICA  
Server Technology, Inc.  
1040 Sandhill Road  
Reno, NV 89521  
United States  
1.775.284.2000 Tel  
1.775.284.2065 Fax  
sales@servertech.com  
www.servertech.com  
www.servertechblog.com

Western Europe, Middle East and  
Africa  
Server Technology  
Fountain Court  
2 Victoria Square  
Victoria Street  
St. Albans  
AL1 3TF  
United Kingdom  
+44 (0) 1727 884676 Tel  
+44 (0) 1727 220815 Fax  
salesint@servertech.com

Central Europe, Eastern Europe and  
Russia  
Niederlassung Deutschland  
Server Technology LLC  
42119 Wuppertal  
Germany  
Tel: + 49 202 693917 x 0  
Fax: + 49 202 693917-10  
salesint@servertech.com

APAC  
Server Technology  
Room 2301, 23/F, Future Plaza  
111-113 How Ming Street,  
Kwun Tong, Hong Kong  
Direct line: +852 3916 2048  
Fax Line: +852 3916 2002  
salesint@servertech.com