



Cisco NCS 520 Hardware Installation Guide

First Published: 2018-05-10

Last Modified: 2018-08-10

Americas Headquarters

Cisco Systems, Inc.
170 West Tasman Drive
San Jose, CA 95134-1706
USA
<http://www.cisco.com>
Tel: 408 526-4000
800 553-NETS (6387)
Fax: 408 527-0883



CONTENTS

CHAPTER 1

Safety Warnings 1

- Standard Warning Statements 1
- Safety Guidelines for Personal Safety and Equipment Protection 2
- Safety Precautions for Module Installation and Removal 2
- Safety with Electricity 3
- Power Supply Considerations 6
 - Power Connection Guidelines 6
 - Guidelines for DC-Powered Systems 6
 - Guidelines for AC-Powered Systems 7
 - Prevent Power Loss 7
- Preventing ESD Damage 7

CHAPTER 2

Cisco NCS 520 Overview 9

- Features 9
- External Interfaces 12
 - Network Interfaces 12
 - External Alarm Inputs 12
 - Management Interfaces 12
 - Management ENET Port 12
 - RS232 Console Port 12
 - Zero Touch Provisioning Button 13
- Power Supply and Fans 13
- Licensing 13

CHAPTER 3

Prepare for Installation 15

- Site Planning 15

General Precautions	15
Site Planning Checklist	15
Site Selection Guidelines	16
Airflow for Site Planning	16
Environmental Requirements	17
Physical Characteristics	17
Airflow Guidelines	17
Airflow Guidelines for ETSI Rack Installation	18
Floor Loading Considerations	18
Site Power Guidelines	18
Electrical Circuit Requirements	19
Site Cabling Guidelines	19
Asynchronous Terminal Connections	20
Interference Considerations	20
Rack-Mounting Guidelines	21
Precautions for Rack-Mounting	21
Rack Selection Guidelines	21
Receive the Device	22
Unpack and Verify Shipped Contents	23
Tools and Equipment	24

CHAPTER 4

Install the Device	25
Rack Compatibility	25
Rack Types	25
Set up Device on Rack, Wall, or Desktop	27
Rack Mount	27
Install Rack Brackets	27
Set up Device on Rack	30
Wall Mount	33
Install Wall Brackets	34
Wall Mount the Device	35
Desktop Mount	36
Ground the Device	36
Connect Power Cables	37

Install AC Power Cable	37
Activate AC Power Supply	38
Install DC Power Cable	38
Activate DC Power Supply	39
Connect Gigabit Ethernet Ports	40
Connect SFP Modules	40
Install SFP Modules	41
Remove SFP Modules	41
Connect Fiber Optic SFP Modules	42
Connect RJ-45 Connector	43
Connect Chassis to Network	43
Connect to EIA Console Port	43
Connect a Management Ethernet Cable	44
Connect Cable to Copper Gigabit Ethernet Port	44

CHAPTER 5**Configure the Device 45**

Power up the Device	45
Verify the Front Panel LEDs	45
Verify the Hardware Configuration	46
Check Hardware and Software Compatibility	46
Configure Device at Startup	46
Access the CLI Using the Console	47
Configure Global Parameters	48
Check the Running Configuration Settings	49
Save the Running Configuration to NVRAM	49
Safely Power Down the Device	49

CHAPTER 6**Troubleshooting Aids 51**

Verify Pinout	51
Time-of-Day Port Pinouts	51
Alarm Port Pinouts	52
Management Ethernet Port Pinouts	52
Check Optical Fiber Specifications	52
Check Alarm Conditions	53

Check LED Indicators	53
Power LED	53
CPU Management Port LEDs	54
SFP+ LEDs	54
Copper GE Ports	54
Alarm LED	55



CHAPTER 1

Safety Warnings

This handout topic lists the safety warnings necessary for handling this product. Before you install or service the chassis, review these safety warnings to avoid injuring yourself or damaging the equipment.

For a complete list of translated safety warnings, see the [Regulatory Compliance and Safety Information—Cisco NCS 520](#) document.

The safety warnings are grouped under the following sections:

- [Standard Warning Statements, on page 1](#)
- [Safety Guidelines for Personal Safety and Equipment Protection, on page 2](#)
- [Safety Precautions for Module Installation and Removal, on page 2](#)
- [Safety with Electricity, on page 3](#)
- [Power Supply Considerations, on page 6](#)
- [Preventing ESD Damage, on page 7](#)

Standard Warning Statements



Warning This unit is intended for installation in restricted access areas. A restricted access area can be accessed only by using a special tool, lock and key, or other means of security. Statement 1017



Warning Ultimate disposal of this product must be handled according to all national laws and regulations. Statement 1040



Warning To prevent the system from overheating, do not operate it in an area that exceeds the maximum recommended ambient temperature of 158°F (70°C). Statement 1047



Warning Mount the device on a rack that is permanently affixed to the building. Statement 1049

**Warning**

This device is a Class A Device and is registered for EMC requirements for industrial use. You must be aware. If sold or purchased by mistake, do replace with a residential-use type. Statement 294

**Warning**

This device is a class A product. In a domestic environment, this product may cause radio interference in which case you may be required to take adequate measures. Statement 340

Safety Guidelines for Personal Safety and Equipment Protection

The following guidelines ensure your safety and protect the equipment. This list does not include all the potentially hazardous situations. Therefore, you must be alert.

- Before moving the system, always disconnect all power cords and interface cables.
- Never assume that power is disconnected from a circuit; always check.
- Before and after installation, keep the chassis area clean and dust free.
- Keep tools and assembly components away from walk areas where you or others can trip over them.
- Do not work alone if potentially hazardous conditions exist.
- Do not perform any action that creates a potential hazard to people or makes the equipment unsafe.
- Do not wear loose clothing that may get caught in the chassis.
- When working under conditions that may be hazardous to your eyes, wear safety glasses.

Safety Precautions for Module Installation and Removal

Be sure to observe the following safety precautions when you work on the chassis.

**Warning**

Class 1 laser product. Statement 1008

**Warning**

Do not stare into the beam or view it directly with optical instruments. Statement 1011

**Warning**

Invisible laser radiations present. Statement 1016

**Warning**

Invisible laser radiation may be emitted from disconnected fibers or connectors. Do not stare into beams or view directly with optical instruments. Statement 1051

Safety with Electricity



Warning Before working on a chassis or with power supplies, unplug the power cord on AC units. Disconnect the power at the circuit breaker on DC units. Statement 12



Warning Before working on equipment that is connected to power lines, remove jewelry (including rings, necklaces, and watches). Metal objects heat up when connected to power and ground and can cause serious burns or weld the metal object to the terminals. Statement 43



Warning Avoid using or servicing any equipment that has outdoor connections during an electrical storm. There may be a risk of electric shock from lightning. Statement 1088



Warning Before performing any of the following procedures, ensure that power is removed from the DC circuit. Statement 1003



Warning Read the installation instructions before connecting the system to the power source. Statement 1004



Warning This product relies on the building's installation for short-circuit (overcurrent) protection. For a DC installation, ensure that the branch circuit breaker is rated a maximum 15A for DC systems. For AC systems, 15 A for voltages greater than 200 Vac; 20 A for voltages below 127 Vac. Statement 1005



Warning When you connect or disconnect the power and relay connector with power applied, an electrical arc can occur. This action can cause an explosion in hazardous area installations. Be sure that power is removed from the switch and alarm circuit. Be sure that power cannot be accidentally turned on or verify that the area is nonhazardous before proceeding. Failure to securely tighten the power and relay connector captive screws can result in an electrical arc if the connector is accidentally removed. Statement 1058



Warning Take care when connecting units to the supply circuit so that wiring is not overloaded. Statement 1018



Warning The plug-socket combination must be accessible always, because it serves as the main disconnecting device. Statement 1019



Warning To avoid electric shock, do not connect safety extra-low voltage (SELV) circuits to telephone-network voltage (TNV) circuits. LAN ports contain SELV circuits, and WAN ports contain TNV circuits. Some LAN and WAN ports both use RJ45 connectors. Use caution when connecting cables. Statement 1021



Warning A readily accessible two-poled disconnect device must be incorporated in the fixed wiring. Statement 1022



Warning To reduce the risk of fire, use only 26 AWG or larger telecommunication line cord. Statement 1023



Warning This equipment must be grounded. Never defeat the ground conductor or operate the equipment in the absence of a suitably installed ground conductor. Contact the appropriate electrical inspection authority or an electrician if you are uncertain that suitable grounding is available. Statement 1024



Warning Use copper conductors only. Statement 1025



Warning This unit may have more than one power supply connection. All connections must be removed to de-energize the unit. Statement 1028



Warning To prevent personal injury or damage to the chassis, never attempt to lift or tilt the chassis using the handles on modules (such as power supplies, fans, or cards). These types of handles are not designed to support the weight of the unit. Statement 1032



Warning Connect the unit only to the DC power source that complies with the safety extra-low voltage (SELV) requirements in IEC 60950 based safety standards. Statement 1033



Warning Do not use this product near water. For example, near a bath tub, wash bowl, kitchen sink or laundry tub, in a wet basement, or near a swimming pool. Statement 1035



Warning This product requires short-circuit (overcurrent) protection, to be provided as part of the building installation. Install only in accordance with national and local wiring regulations. Statement 1045



Warning When installing or replacing the unit, ensure the ground connection first and disconnected last. Statement 1046



Warning Failure to securely tighten the power and relay connector captive screws can result in an electrical arc if the connector is accidentally removed. Statement 1058



Warning This equipment is intended to be grounded to comply with emission and immunity requirements. Ensure that the switch functional ground lug is connected to earth ground during normal use. Statement 1064



Warning When you connect or disconnect the power and/or alarm connector with power applied, an electrical arc can occur. This could cause an explosion in hazardous area installations. Be sure that all power is removed from the switch and any other circuits. Be sure that power cannot be accidentally turned on or verify that the area is nonhazardous before proceeding. Statement 1058



Warning Installation of the equipment must comply with local and national electrical codes. Statement 1074

When working on equipment that is powered by electricity, follow these guidelines:

- Locate the room's emergency power-off switch. If an electrical accident occurs, you know where to quickly turn off the power.
- Before starting work on the system, turn off the DC main circuit breaker and disconnect the power terminal block cable.
- Disconnect all power when:
 - Working on or near power supplies
 - Installing or removing a device chassis or network processor module
 - Performing most hardware upgrades
- Never install equipment that appears damaged.
- Carefully examine your work area for possible hazards, such as moist floors, ungrounded power extension cables, and missing safety grounds.
- Never assume that power is disconnected from a circuit; always check.
- Never perform any action that creates a potential hazard to people or makes the equipment unsafe.
- If an electrical accident occurs and you are uninjured:
 - Use caution to avoid injuring yourself.
 - Turn off power to the device.

- If possible, send another person to get medical aid. Otherwise, determine the condition of the victim, and then call for help.
- Determine whether the person needs rescue pulsing or external cardiac compressions; then take appropriate action.

Use the following guidelines when working with any equipment that is disconnected from a power source, but connected to telephone wiring or network cabling:

- When installing or modifying telephone lines, use caution.
- Never install telephone jacks in wet locations unless the jack is designed to handle such locations.
- Never install telephone wiring during a lightning storm.

Power Supply Considerations

Check the power at your site to ensure that you are receiving clean power (free of spikes and noise). If necessary, install a power conditioner.

Power Connection Guidelines

This section provides guidelines for connecting the device power supplies to the site power source.



Warning The plug-socket combination must be accessible at all times, because it serves as the main disconnecting device.



Warning This equipment must be grounded. To reduce the risk of electric shock, never defeat the ground conductor or operate the equipment in the absence of a suitably installed ground conductor. Contact the appropriate electrical inspection authority or an electrician if you are uncertain that suitable grounding is available.



Warning This product requires short-circuit (overcurrent) protection to be provided as part of the building installation. Install only in accordance with national and local wiring regulations.

Guidelines for DC-Powered Systems

Basic guidelines for DC-powered systems include the following:

- Each chassis power supply has its own dedicated input power source. The source must comply with the safety extra-low voltage (SELV) requirements in the UL 60950, CSA 60950, EN 60950, and IEC 60950 standards.
- Protect the circuit by a dedicated two-pole circuit breaker. Ensure that the circuit breaker is sized according to the power supply input rating and local or national code requirements.

- The circuit breaker is considered as the disconnect device and is easily accessible.
- The system ground is the power supply and chassis ground.
- Use the grounding lug to attach a wrist strap for ESD protection during servicing.
- Do not connect the DC return wire to the system frame or to the system-grounding equipment.
- Ensure that the DC return is grounded at the source side.
- Ensure that each power feed of the equipment is connected to different sources.

Guidelines for AC-Powered Systems

Basic guidelines for AC-powered systems include the following:

- Each chassis power supply has its own dedicated branch circuit.
- Ensure that the circuit breaker is sized according to the power supply input rating and local or national code requirements.
- The AC power receptacles that are used to plug in the chassis must be the grounding type. The grounding conductors that connect to the receptacles must connect to protective earth ground at the service equipment.

Prevent Power Loss

Use the following guidelines to prevent power loss to the device:

- To prevent input power loss, ensure that the maximum load on each circuit supplying the power is within the current ratings of the wiring and breakers.
- In some systems, you can use an UPS to protect against power failures at your site. Avoid UPS types that use ferroresonant technology. These UPS types can become unstable with systems such as the device, which can have substantial current-draw fluctuations due to bursty data traffic patterns.

Determining power requirements is useful for planning the power distribution system to support the device.

Preventing ESD Damage



Warning This equipment needs to be grounded. Use a green and yellow 6 AWG ground wire to connect the host to earth ground during normal use.

Electrostatic Discharge (ESD) can damage equipment and impair electrical circuitry. ESD may occur when electronic printed circuit cards are improperly handled and can cause complete or intermittent failures. When removing and replacing modules, always follow these ESD prevention procedures:

- Ensure that the device chassis is electrically connected to earth ground.
- Wear an ESD-preventive wrist strap, ensuring that it makes good skin contact. To channel unwanted ESD voltages safely to ground, connect the clip to an unpainted surface of the chassis frame. To guard against ESD damage and shocks, the wrist strap and cord must operate effectively.
- If no wrist strap is available, ground yourself by touching a metal part of the chassis.

- When installing a component, use any available ejector levers or captive installation screws to properly seat the bus connectors in the backplane or midplane. These devices prevent accidental removal, provide proper grounding for the system, and help to ensure that bus connectors are properly seated.
- When removing a component, use available ejector levers or captive installation screws, if any, to release the bus connectors from the backplane or midplane.
- Handle components by only their handles or edges; do not touch the printed circuit boards or connectors.
- Place a removed component board side up on an antistatic surface or in a static-shielding container. If you plan to return the component to the factory, immediately place it in a static-shielding container.
- Avoid contact between the printed circuit boards and clothing. The wrist strap only protects components from ESD voltages on the body; ESD voltages on clothing can still cause damage.
- Never attempt to remove the printed circuit board from the metal carrier.

For the safety of your equipment, periodically check the resistance value of the antistatic wrist strap. Maintain the value between 1 and 10 Mohm.



CHAPTER 2

Cisco NCS 520 Overview

The Cisco NCS 520 is a small form factor (1RU) next-generation Layer 2 device.

For more information on its features and benefits, see the [Cisco Network Convergence System 520 Data Sheet](#).

- [Features, on page 9](#)
- [External Interfaces, on page 12](#)
- [Power Supply and Fans, on page 13](#)
- [Licensing, on page 13](#)

Features

The Cisco NCS 520 includes these seven variants:

- N520-4G4Z-A (Base)
- N520-X-4G4Z-A (Premium)
- N520-X-4G4Z-D (Premium)
- N520-20G4Z-A (Base)
- N520-20G4Z-D (Base)
- N520-X-20G4Z-A (Premium)
- N520-X-20G4Z-D (Premium)

This subfamily of variants have fixed ENET interfaces (4 x 1GE + 4 x 10GE ports available) and (20 x 1GE + 4 x 10GE ports available), with a single or dual power supply for AC and dual power supplies for DC.

The following figures display the front and back views of the variants. The front views display the power supply, the ports, and the LEDs. The rear views display the fan vents and the ground.

Figure 1: Cisco NCS 520 (N520-4G4Z-A)

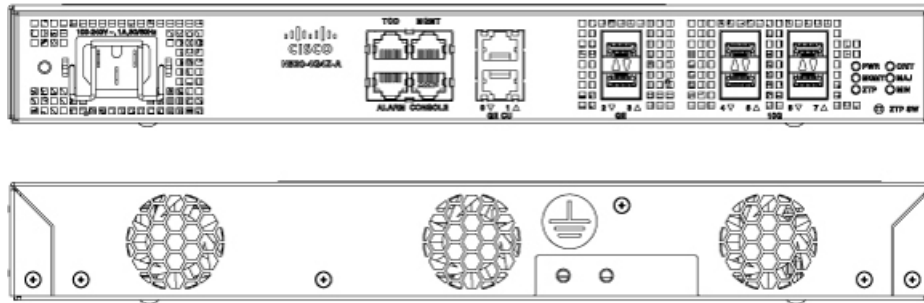

367343

Figure 2: Cisco NCS 520 (N520-X-4GAZ-A)

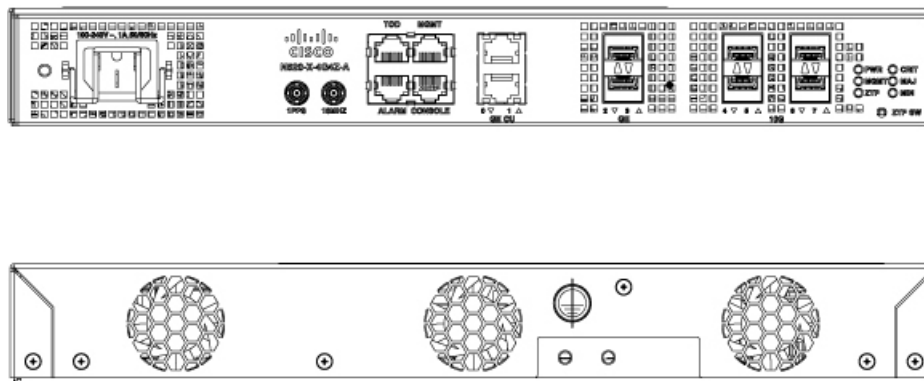

367279

Figure 3: Cisco NCS 520 (N520-X-4G4Z-D)

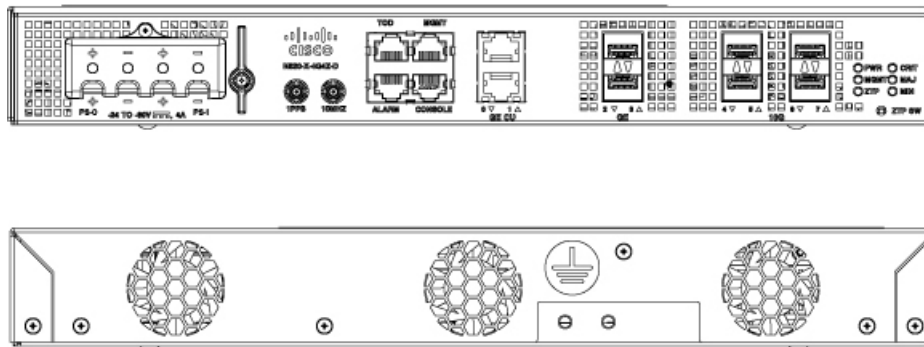

367344

Figure 4: Cisco NCS 520 (N520-20G4Z-A)

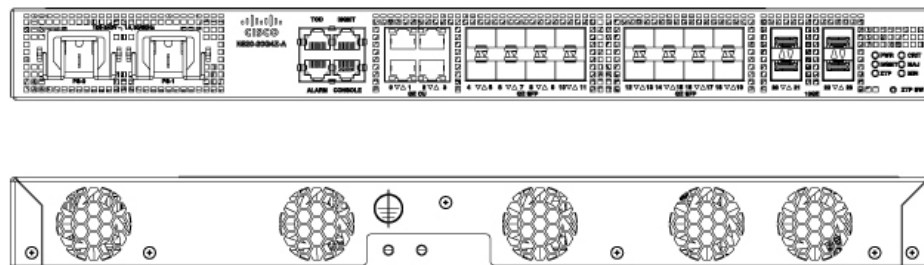

367469

Figure 5: Cisco NCS 520 (N520-20G4Z-D)

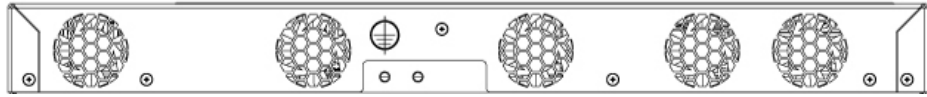
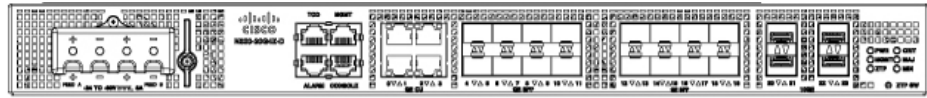

367468

Figure 6: Cisco NCS 520 (N520-X-20G4Z-A)

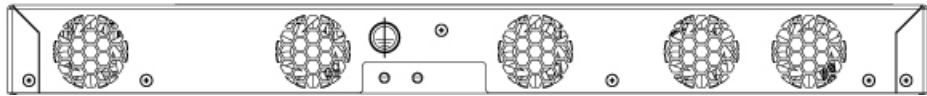
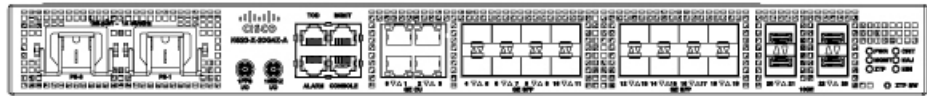

367334

Figure 7: Cisco NCS 520 (N520-X-20G4Z-D)

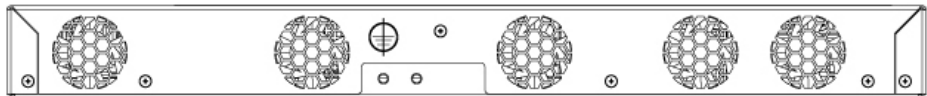
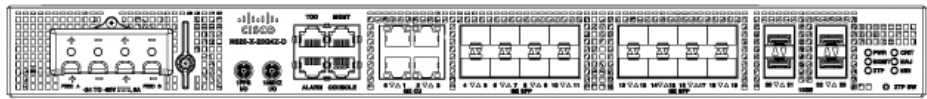

367467

The following table lists the number and type of supported ports:

Table 1: Supported Ports

NCS 520 Subfamily	1 GE Port	10 GE Port
N520-4G4Z-A	4	4
N520-X-4G4Z-A		
N520-X-4G4Z-D		
N520-20G4Z-A	20	4
N520-20G4Z-D		
N520-X-20G4Z-A		
N520-X-20G4Z-D		

For more information on the following, see the [Cisco Network Convergence System 520 Data Sheet](#):

- System specification
- Power specification
- Environment specification
- Safety and compliance
- Ordering information

External Interfaces

The Cisco NCS 520 has these external physical interfaces on the front panel:

Network Interfaces

The network interfaces are provided through these fixed ports:

- GE SFP ports—supports 100/1000 modes
- GE Copper RJ-45 ports—supports 10/100/1000 operation
- 10GE SFP+—supports 10G/1G mode depending on the SFP+/SFP in the network interface slot

External Alarm Inputs

The device supports four dry contact alarm inputs through an RJ-45 jack on the front panel.

The alarm condition is normally open, which indicates that no current flows through the alarm circuit, and the alarm is generated when the current is flowing. Each alarm input can be provisioned as being critical, major, or minor.

Management Interfaces

The Cisco NCS 520 has the following management interfaces:

Management ENET Port

A single management copper ENET port supporting 10/100/1000Base-T operation is provided at the front panel. It uses a standard RJ-45 jack.



Note The management ENET port is not a data plane port.

RS232 Console Port

The RS232 console port provides transmission (Tx), reception (Rx), and grounding (Gnd).

Zero Touch Provisioning Button

The Zero Touch Provisioning (ZTP) button on the front panel initiates the ZTP process on a short press of less than eight seconds. Pressing the ZTP button for more than eight seconds causes a system reset.

Power Supply and Fans

The Cisco NCS 520 supports either AC or DC power supplies in a 1+1 redundant configuration except N520-4G4Z-A and N520-X-4G4Z-A.



Note The power supply units are built in and are not modular.



Note This product requires surge protection as part of the building installation. This requirement is in compliance with the Telcordia GR-1089 NEBS standard for electromagnetic compatibility and safety. Provide an external surge protective device (SPD) at the AC power service equipment.



Note For DC systems, if a surge of more than 500 V is expected, add an external surge device for protection.

The Cisco NCS 520 has fixed fans as a part of the system. The system is designed to operate at its maximum operating temperature of 70°C and at an altitude of 300 meters. If a single fan fails, the system runs at a maximum operating temperature of 65°C. The fan is not removable and therefore, during a failure, the system must be replaced.



Note In case of power supply or fan failure, we recommend that you get a qualified technician to replace the faulty device within 96 hours.

Licensing

The Cisco NCS 520 supports the following types of licenses:

- Metro Access (default)
- Port Licensing—Port Upgrade license is available as a "Pay as you Grow" model.
 - 10G upgrade license

The following method is used to activate the licenses:

- Software Licensing—The Cisco Software License Activation feature is a set of processes and components that activate Cisco software feature sets. You can obtain and validate fee-based Cisco software licenses.



Note Licenses by the Cisco Software Licensing are tied to the UDI of the chassis, and a corresponding watchtower device certificate (WDC) is stored in the system.



CHAPTER 3

Prepare for Installation

Before you install the Cisco NCS 520, you must prepare your site for the installation.

Preparing your site involves these tasks:

- [Site Planning, on page 15](#)
- [Receive the Device, on page 22](#)

Site Planning

The following sections describe how to plan the site for installing of the Cisco NCS 520.

General Precautions

Observe the following general precautions when using and working with your chassis:

- Keep your system components away from radiators and heat sources, and do not block cooling vents.
- Do not spill food or liquids on your system components, and never operate the product in a wet environment.
- Do not push any objects into the openings of your system components. Doing so can cause fire or electric shock by shorting out interior components.
- Position system cables and power supply cable carefully. Route system cables and the power supply cable and plug so that they are not stepped on or tripped over. Ensure that nothing rests on your system component cables or power cable.
- Do not modify power cables or plugs. Consult a licensed electrician or your power company for site modifications. Always follow your local and national wiring rules.
- If you turn off your system to avoid damage to the system components, wait at least 30 seconds before turning it on again.

Site Planning Checklist

Use the following checklist to carry out all site planning tasks:

- The site meets environmental requirements.

- The site's air conditioning system can compensate for the heat dissipation of the chassis.
- The floor space that the chassis occupies can support the weight of the system.
- Electrical service to the site complies with the safety with electricity requirements.
- The electrical circuit servicing the chassis complies with the power supply requirements.
- Console port wiring and cabling limitations have been considered in accordance to TIA/EIA-232F.
- The chassis Ethernet cabling distances are within prescribed limits.
- The equipment rack where the chassis is to be installed complies with prescribed requirements.
- The following factors have been carefully considered when selecting rack: location, safety, ease of maintenance, and proper airflow.

Site Selection Guidelines

The device requires specific environmental operating conditions. Temperature, humidity, altitude, and vibration can affect the performance and reliability of the device.

The device is designed to meet the industry EMC, safety, and environmental standards.

Airflow for Site Planning

Table 2: Cisco NCS 520 Airflow

Device	Feature	Maximum System Airflow (CFM) at Maximum System Temperature
N520-4G4Z-A	Cisco NCS 520 - 4xGE + 4x10GE, commercial temp, AC power supply	25.0
N520-X-4G4Z-A	Cisco NCS 520 - 4xGE + 4x10GE, industrial temp, AC power supply	28.0
N520-X-4G4Z-D	Cisco NCS 520 - 4xGE + 4x10GE, industrial temp, DC power supply	
N520-20G4Z-A	Cisco NCS 520 - 20xGE + 4x10GE, commercial temp, AC power supply	50.0
N520-20G4Z-D	Cisco NCS 520 - 20xGE + 4x10GE, commercial temp, DC power supply	
N520-X-20G4Z-A	Cisco NCS 520 - 20xGE + 4x10GE, industrial temp, AC power supply	57.0
N520-X-20G4Z-D	Cisco NCS 520 - 20xGE + 4x10GE, industrial temp, DC power supply	

Environmental Requirements

Environmental monitoring of the chassis protects the system and components from damage due to excessive voltage and temperature conditions. To ensure normal operation and avoid unnecessary maintenance, plan and prepare your site configuration *before* installation. After installation, ensure that the environmental characteristics continue to be met.

For an outside plant installation (cell site cabinet, hut, and so on), you require to protect the chassis against airborne contaminants, dust, moisture, insects, pests, corrosive gases, polluted air, or other reactive elements. We recommend that you install the unit in a fully sealed enclosure or cabinet. Examples of such cabinets include IP65 cabinets with heat exchanger complying with Telcordia GR487. Temperature must be maintained within -40°C to 70°C .

Place the device inside a space that is protected from direct weather and environmental stresses by an enclosure.

Ensure the operating climate as defined by Class 2 of GR-3108-CORE for premium variants.

- -40°C (-40°F) and 70°C (158°F)
- 5 and 85% RH

Ensure the operating climate as defined by Class 1 of GR-3108-CORE for base variants.

- -5°C (23°F) and 50°C (122°F)
- < 15 to 85% RH

Physical Characteristics

To set the device at its proper location, be familiar with its physical characteristics.

Airflow Guidelines

Cool air is circulated through the chassis by fans that are located along the back of the device.

The internal fans maintain acceptable operating temperatures for the internal components by drawing in cool air through the vents and circulating that air through the chassis.

The direction of airflow is from front-to-back.

To ensure adequate airflow through the equipment rack, we recommend that you always maintain a minimum clearance distance as mentioned in the following specifications.

- Front clearance—5 inches (12.7 centimeters)
- Rear clearance—3.93 inches (10 centimeters)

Note the following points:

- When installing chassis in a back-to-back position with another device, ensure a minimum of 3.93 inches (10 centimeters) airflow clearance between them. Also, ensure that the device behind the chassis is not installed in a way that it blows air into the chassis.
- An over-temperature condition may occur within the rack, if airflow through the rack and the device is restricted, or if the air that is drawn into the rack is warm.

- Ensure that the site is dust free. Dust tends to clog the device fans, reducing the flow of cooling air through the equipment rack and the devices that occupy it, thus increasing the risk of an over-temperature condition.
- Enclosed racks must have adequate ventilation. Because each device generates heat, ensure that the racks are not congested. An enclosed rack must have louvered sides and a fan to provide cool air. Heat that is generated by the equipment near the bottom of the rack may be drawn upward into the intake ports of the equipment above.
- When mounting a chassis on an open rack, ensure that the rack frame does not block the exhaust fans.
- When a rack-installed equipment fails, especially equipment on an enclosed rack, if possible try operating the equipment by itself. Power off all other equipment on the rack (and in adjacent racks) to give the device maximum cooling air and clean power.
- Avoid installing the chassis in a location in which the chassis air intake vents may draw in the exhaust air from an adjacent equipment. Consider how the air flows through the device; the airflow direction is from front to back, with ambient air drawn in from the vents located on the sides of the chassis.

**Caution**

When mounting the device on any type of rack equipment, ensure that the temperature of inlet air to the device does not exceed the specified operating temperature limits of the product.

Airflow Guidelines for ETSI Rack Installation

When you install a device on a 2 or 4-post rack, the front and rear doors of the cabinet must be removed. We recommend that you always maintain a minimum clearance distance as mentioned the following.

- Front clearance—5 inches (12.7 centimeters)
- Rear clearance—3.93 inches (10 centimeters)

To mount the chassis in a 4-post enclosed cabinet, ensure a minimum of 3.93 inches (10 centimeters) of clearance on each side of the chassis.

Floor Loading Considerations

Ensure that the floor under the rack supporting the chassis is able to support the combined weight of the rack and all the other installed equipment.

For additional information about floor loading requirements, see the [GR-63-CORE, Network Equipment Building System \(NEBS\) Requirements: Physical Protection](#) document.

Site Power Guidelines

The chassis has specific power and electrical wiring requirements. Adhering to these requirements ensures reliable operation of the system. Follow these precautions and recommendations when planning your site power for the chassis:

- The redundant power option provides a second, identical power supply to ensure uninterrupted power supply.



Note Applicable only to Cisco N540-24Z8Q2C-SYS, N540X-ACC-SYS, and N540-ACC-SYS routers.

- Connect each power supply to a separate input power source. Otherwise, it results in total power failure to the system due to a fault in the external wiring or a tripped circuit breaker.
- To prevent loss of input power, ensure that the maximum load on each circuit is within the current ratings of the wiring and the breakers.
- Check the power at your site before installation, and periodically after installation, to ensure that you are receiving clean power. If necessary, install a power conditioner.
- Provide proper grounding to avoid personal injury and damage to the equipment due to power surges or lightning striking power lines. The chassis ground must be attached to a central office or other interior ground system.



Warning This product requires short-circuit (overcurrent) protection to be provided as part of the building installation. Install only in accordance with national and local wiring regulations. Statement 1045



Caution This product requires external surge protection device for both AC and DC power feeds to the equipment. For DC power feed, the surge protective device (SPD) must handle common mode and differential mode surge as per the local standards.



Note The chassis installation must comply with all the applicable codes, and is approved for use with only copper conductors. The ground bond-fastening hardware must be compatible and preclude loosening, deterioration, and electrochemical corrosion of hardware and joined material. Attachment of the chassis ground to a central office or other interior ground system must be made with a 6-AWG gauge wire copper ground conductor.

Electrical Circuit Requirements

Each chassis requires a dedicated electrical circuit. If you equip the device with dual-power feeds, provide a separate circuit for each power supply to avoid compromising the power redundancy feature.

The chassis supports both DC source or an AC source. Ensure that equipment grounding is present and observe power-strip ratings. Make sure that the total ampere rating of all the products plugged into the power strip does not exceed 80% of the rating.

Site Cabling Guidelines

This section contains guidelines for wiring and cabling at your site. When preparing your site for network connections to the chassis, consider the type of cable that is required for each component and cable limitations. Consider the distance limitations for signaling, electromagnetic interference (EMI), and connector compatibility. Possible cable types are fiber, thick or thin coaxial, foil twisted-pair, or unshielded twisted-pair cabling.

Also, consider any additional interface equipment that you need, such as transceivers, hubs, switches, modems, channel service units (CSU), or data service units (DSU).

Before you install the chassis, have on hand all additional external equipment and cables. For information about ordering, contact a Cisco customer service representative.

The extent of your network and the distances between the network interface connections depend, in part, on the following factors:

- Signal type
- Signal speed
- Transmission medium

The distance and rate limits that are referenced in the following sections are the IEEE-recommended maximum speeds and distances for signaling purposes. Use this information as a guideline when planning your network connections *before* installing the chassis.

If wires exceed the recommended distances, or if wires pass between buildings, give special consideration to the possibility of a lightning strike in your vicinity. The electromagnetic pulse due to lightning or other high-energy phenomena can easily couple enough energy into unshielded conductors to destroy electronic devices. If you have had problems of this sort in the past, you may want to consult experts in electrical surge suppression and shielding.

Asynchronous Terminal Connections

The chassis provides a console port to connect a terminal or computer for local console access. The port has an RJ-45 connector and supports RS-232 asynchronous data with distance recommendations that are specified in the IEEE RS-232 standard. The available baud rate is 115200 bauds.

Interference Considerations

When wires are run for any significant distance, there is a risk of receiving stray signals on the wires as interference. If interference signals are strong, it results in data errors or equipment damage.

The following sections describe the sources of interference and how to minimize their effects on the chassis.

Electromagnetic Interference

All the equipment that is powered by AC current can propagate electrical energy that can cause EMI and possibly affect the operation of other equipment. The typical sources of EMI are equipment power cords and power service cables from electric utilities.

Strong EMI can destroy the signal drivers and receivers in the chassis. It can even create an electrical hazard by causing power surges through the power lines into installed equipment. These problems are rare, but could be catastrophic.

To resolve these problems, you need specialized knowledge and equipment that could consume substantial time and money. However, you can ensure that you have a properly grounded and shielded electrical environment, paying special attention to the need for electrical surge suppression.

Radio Frequency Interference

When electromagnetic fields act over a long distance, radio frequency interference (RFI) may be propagated. Building wiring can often act as an antenna, receiving the RFI signals and creating more EMI on the wiring.

If you use a twisted-pair cable in your plant wiring with a good distribution of grounding conductors, the plant wiring is unlikely to emit radio interference. If you exceed the recommended distances, use a high-quality twisted-pair cable with one ground conductor for each data signal.

Lightning and AC Power Fault Interference

If signal wires exceed the recommended cabling distances, or if signal wires pass between buildings, you may encounter a lightning strike on the chassis.

The electromagnetic pulse (EMP) generated by lightning or other high-energy phenomena can couple enough energy into unshielded conductors and damage or destroy electronic equipment. For such problems, you must consult with RFI and EMI experts to ensure adequate electrical surge suppression and shielding of signal cables in your operating environment.



Warning

This product requires surge protection as part of the building installation. To comply with the Telcordia GR-1089 NEBS standard for electromagnetic compatibility and safety, an external surge protective device (SPD) is required at the AC or DC power service equipment.

Rack-Mounting Guidelines

The following sections provide guidelines for selecting racks and precautions for mounting the chassis on a rack:

Precautions for Rack-Mounting

Follow these rack-mount guidelines to ensure your safety:

- Ensure that the rack is level and stable before extending a component from the rack.
- Ensure that proper airflow is provided to the components on the rack.
- Do not step on or stand on any component or system when servicing other systems or components on a rack.
- If the rack is provided with stabilizing devices, install the stabilizers before mounting or servicing the chassis.

Rack Selection Guidelines

Ensure the 2 or 4-post, 19 inches (48.3 centimeters) or 23 inches (58.42 centimeters) rack that you select complies with the Electronic Industries Association (EIA) standard for equipment racks (EIA-310-D). The rack must have at least two posts with mounting flanges to mount the chassis.



Caution

When mounting a chassis in any type of rack equipment, ensure that the temperature of the inlet air to the chassis does not exceed the specified operating temperature of the chassis.

The distance between the center lines of the mounting holes on the two mounting posts must be 18.31 inches (46.50 centimeters) \pm 0.06 inch (\pm 0.15 centimeter). The rack-mounting hardware included with the chassis is suitable for most 19 inches (48.3 centimeters) equipment racks.

Install the chassis on a rack with the following features:

- NEBS-compliant, 19 inches (48.3 centimeters) rack or 23 inches (58.42 centimeters).

- EIA or European Telecommunications Standards Institute (ETSI) hole patterns in the mounting rails. The required mounting hardware is shipped with the chassis. If the rack on which you plan to install the chassis has metric-threaded rails, you must provide your own metric-mounting hardware.
- Perforated top and open bottom for ventilation to prevent overheating.
- Leveling feet for stability.

Do not install the device on an enclosed rack because the chassis requires an unobstructed flow of cooling air to maintain the acceptable operating temperature. If you use an enclosed rack, ensure that the airflow requirements are maintained as discussed in the [Airflow Guidelines](#) section.

Receive the Device

Each device is shipped in a container that is strapped to a pallet.

Figure 8: Chassis Package

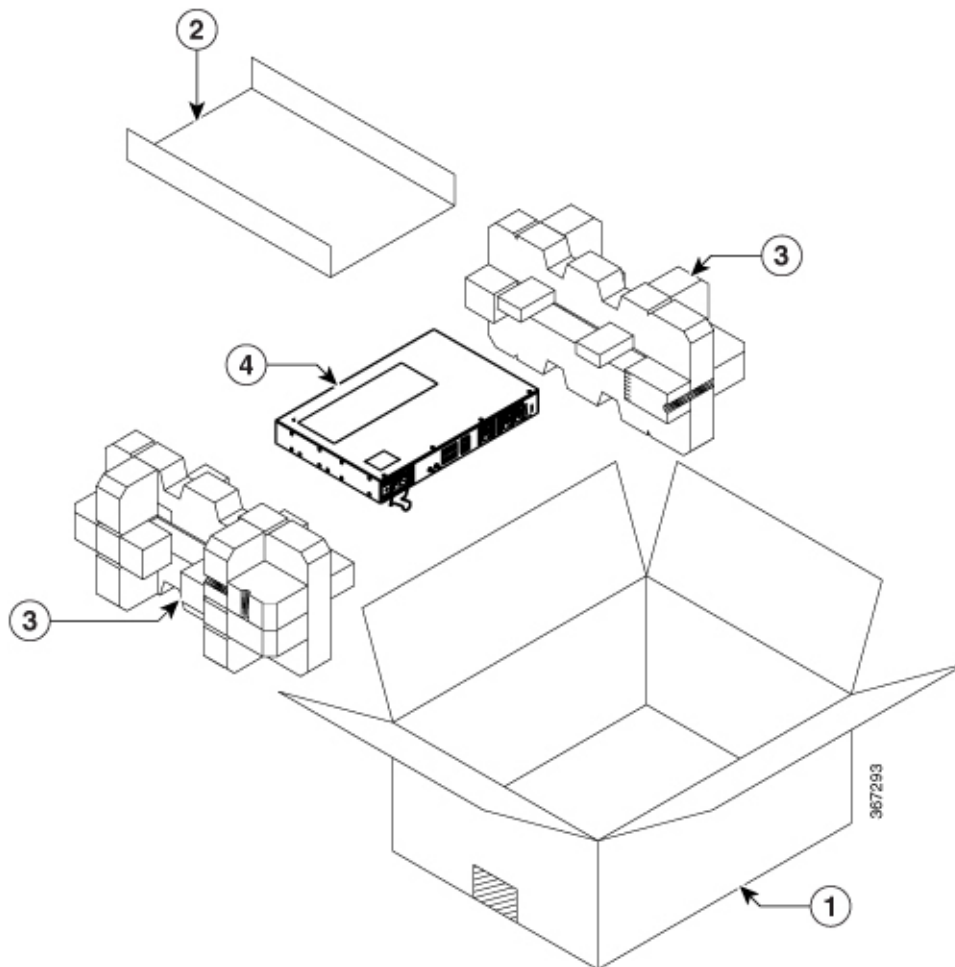

Label	Description	Label	Description
1	Packing carton	3	Assembly packaging material
2	Accessories tray	4	Chassis

Unpack and Verify Shipped Contents

Procedure

-
- Step 1** Inspect the shipping container for any shipping damage. If there is obvious physical damage, contact your Cisco service representative, else continue with the remaining steps.
- Step 2** Unpack the device.
- Step 3** Inspect the device.
- Step 4** Use the following table to verify the contents of the container. Do not discard the shipping container. You will need the container in the future if you move or ship the device.
-

What to do next

Table 3: Default Shipping Container Contents

Component	Description
Device	Cisco NCS 520
ESD, wrist strap (disposable)	One disposable wrist strap (optional)
Documentation	Cisco NCS 500 Series Services Routers Pointer Card
Optional equipment	<p>Check the container for the following optional equipment:</p> <ul style="list-style-type: none"> • Power cord if an AC power supply is shipped. • Lugs if a DC power supply is shipped. <p>Note If you do not specify the type of power cable, US power cable for the AC device variant is supplied.</p>



Note Most Cisco documentation is available online. The chassis Pointer Card that is shipped with your Cisco NCS 500 Series Services Routers contains links and information to other online documentation.



Note If the product is not in use, store the device in the initial packaged condition or in an ESD PE sealed bag with silica gel.

Table 4: Accessories Kit

Variant	Category	PID	Accessories
N520-4G4Z-A N520-X-4G4Z-A	19 inches	N520-RCKMT-19-D2A / N520-RCKMT-19-D2D	Yes
N520-X-4G4Z-D N520-20G4Z-A	23 inches	N520-RCKMT-23-D2A / N520-RCKMT-23-D2D	Yes
N520-20G4Z-D N520-X-20G4Z-A	ETSI	N520-RMT-ETSI-D2A / N520-RMT-ETSI-D2D	Yes
N520-X-20G4Z-D	Wall mount	N520-WALLMT	Yes
	Desktop	NA	Applicable only for N520-4G4Z-A
	Cable bracket	N520-CBL-BRKT	Yes

Tools and Equipment

You need the following tools and equipment to install and upgrade the device and its components:

- ESD-preventive cord and wrist strap
- Antistatic mat or antistatic foam
- Number 1 and Number 2 Phillips-head screwdrivers
- #12-24 pan-head screws to secure the device to the equipment rack.
- Cables for connecting to network ports (based on the configuration)
- Ethernet hub, switch, or PC with a network interface card for connecting to the Ethernet ports
- Console terminal that is configured for 9600 baud, 8 data bits, no parity, no flow control, and 1 stop bit.
- Console cable for connecting to the console port
- Ratcheting torque screwdriver with a Phillips head that exerts up to 30-pound force per square inch (0.02-kilograms force per square millimeter (kgf/mm²)) of pressure.
- Crimping tool as specified by the ground lug manufacturer
- Wire-stripping tools for stripping both 6 and 14-AWG wires
- Tape measure and level
- Ratcheting torque screwdriver with a Phillips head that exerts up to 15 inch-pounds (1.69 newton meters) of torque for attaching the ground wire to the device.



CHAPTER 4

Install the Device

Before you begin this task, ensure that you have read and understood the safety warnings in the [Standard Warning Statements](#) section of the [Safety Warnings](#) handout topic.

Installing the Cisco NCS 520 involves these tasks:

- [Rack Compatibility](#), on page 25
- [Set up Device on Rack, Wall, or Desktop](#), on page 27
- [Ground the Device](#), on page 36
- [Connect Power Cables](#), on page 37
- [Connect Gigabit Ethernet Ports](#), on page 40
- [Connect Chassis to Network](#), on page 43

Rack Compatibility

We recommend that you follow these rack specifications.

Rack Types

Figure 9: Rack specification EIA (19 inches and 23 inches)

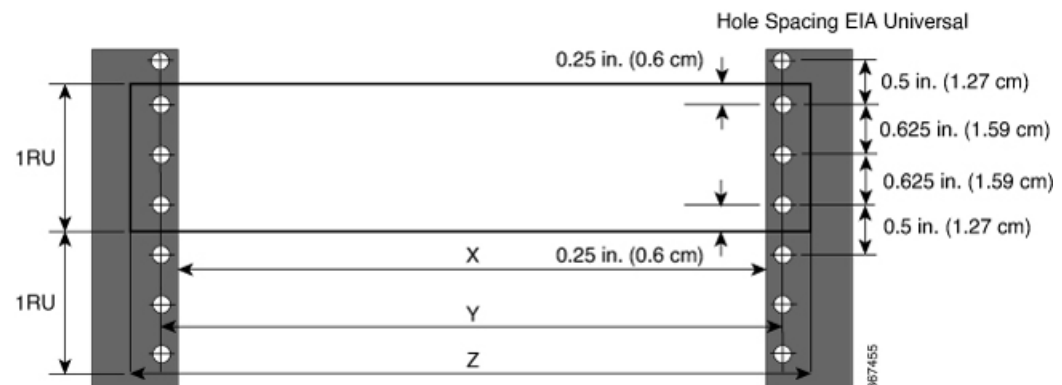
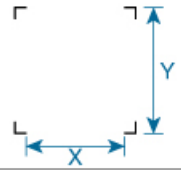
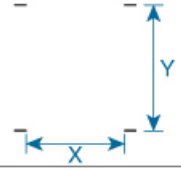
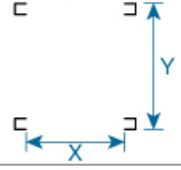

Table 5: Rack specification EIA (19 inches and 23 inches)





Post Type	Rack Type	Rack Front Opening (X)	Rack Mounting Hole Centre-Centre (Y)	Mounting Flange Dimension (Z)
4 Post	19 inches (48.3 centimeters)	17.75 inches (45 centimeters)	18.31 inches (46.5 centimeters)	19 inches (48.2 centimeters)
2 Post				
4 Post	23 inches (58.4 centimeters)	21.75 inches (55.24 centimeters)	22.31 inches (56.6 centimeters)	23 inches (58.4 centimeters)
2 Post				

Figure 10: Four Post Rack Type

4 – Post Type (Hole EIA Universal)		Width Available (X)	Compatibility
All 23" Type rack		552.45mm (21.75")	Yes
All ETSI rack (21" rack)		500.0mm (19.68")	Yes
19" Type rack L-Type Post		17.75" (450.8 mm)	Yes
		17.50" (444.5 mm)	No
19" Type Racks Flat-Post		17.75" (450.8 mm)	Yes
		17.50" (444.5 mm)	No
19" Type racks C-Type Post		17.75" (450.8 mm)	Yes
		17.50" (444.5 mm)	No

367456

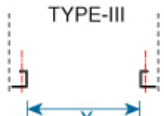
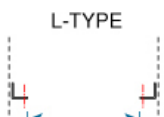
Figure 11: Two Post Rack Type

2 – Post Type (Hole EIA Universal)	X – 19" Rack	Compatibility	X-23" Rack	Compatibility
 <p>TYPE-I</p>	17.75" (450.8 mm)	Yes	21.75" (552.45mm)	Yes
	17.50" (444.5 mm)	No	21.75" (552.45mm)	Yes
 <p>TYPE-II</p>	17.75" (450.8 mm)	Yes	21.75" (552.45mm)	Yes
	17.50" (444.5 mm)	No	21.75" (552.45mm)	Yes
 <p>TYPE-III</p>	17.75" (450.8 mm)	Yes	21.75" (552.45mm)	Yes
	17.50" (444.5 mm)	No	21.75" (552.45mm)	Yes
 <p>L-TYPE</p>	17.75" (450.8 mm)	Yes	21.75" (552.45mm)	Yes
	17.50" (444.5 mm)	No	21.75" (552.45mm)	Yes
 <p>Uneven-TYPE</p>	17.75" (450.8 mm)	Yes	21.75" (552.45mm)	Yes
	17.50" (444.5 mm)	No	21.75" (552.45mm)	Yes

367457

Set up Device on Rack, Wall, or Desktop

You can choose to either set up the Cisco NCS 520 on a rack, wall mount it, or set it up on a desk.

Rack Mount

You must first install rack mounting brackets on to the chassis before you set up the chassis on the rack.

Install Rack Brackets

The device is shipped with rack mounting brackets that are to be secured on the sides of the device.

Procedure

Step 1 Remove the rack mounting brackets from the accessory kit and position them beside the device.

Note You can install the brackets at any of the 3 positions that are shown in the figure.

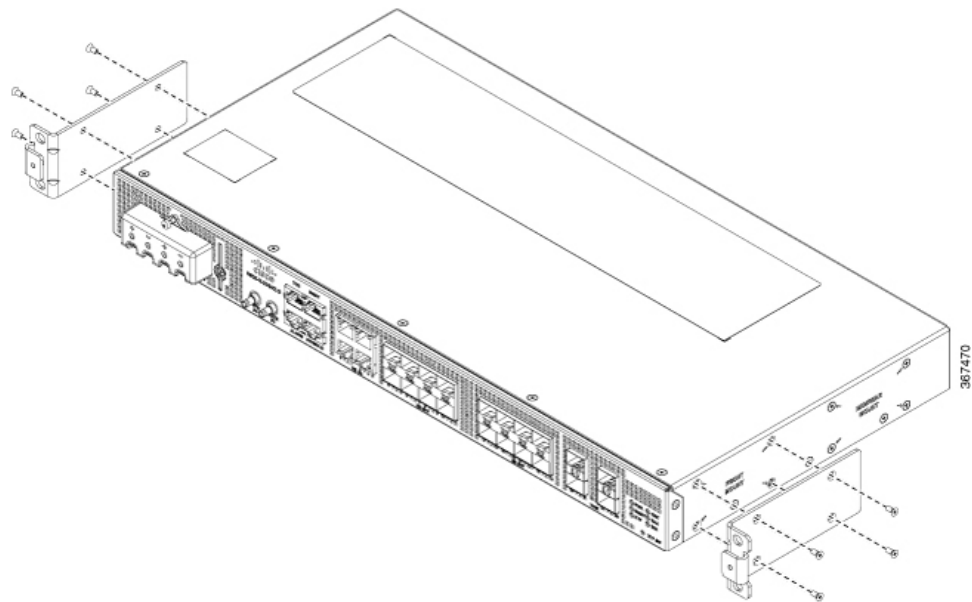
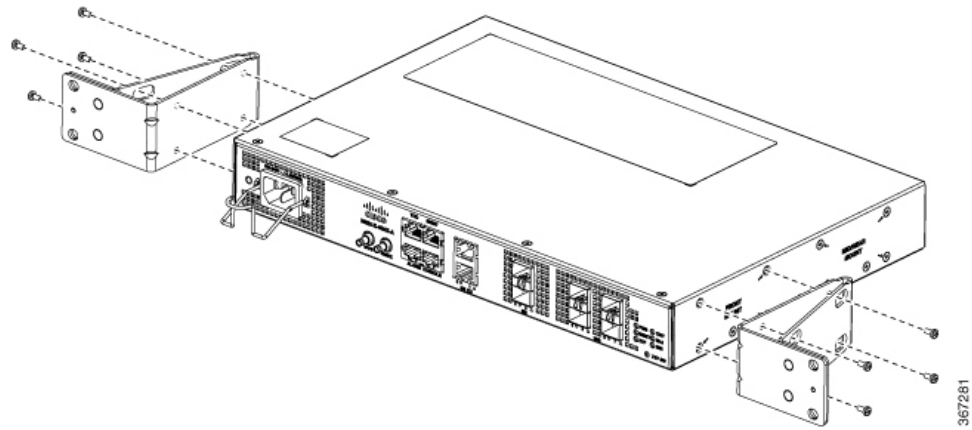
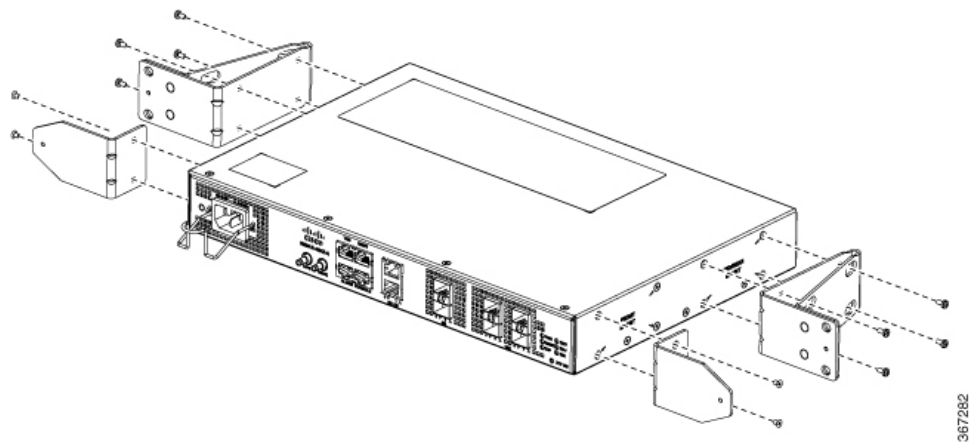
Figure 12: Front Mount Bracket**Figure 13: Middle Mount Bracket**

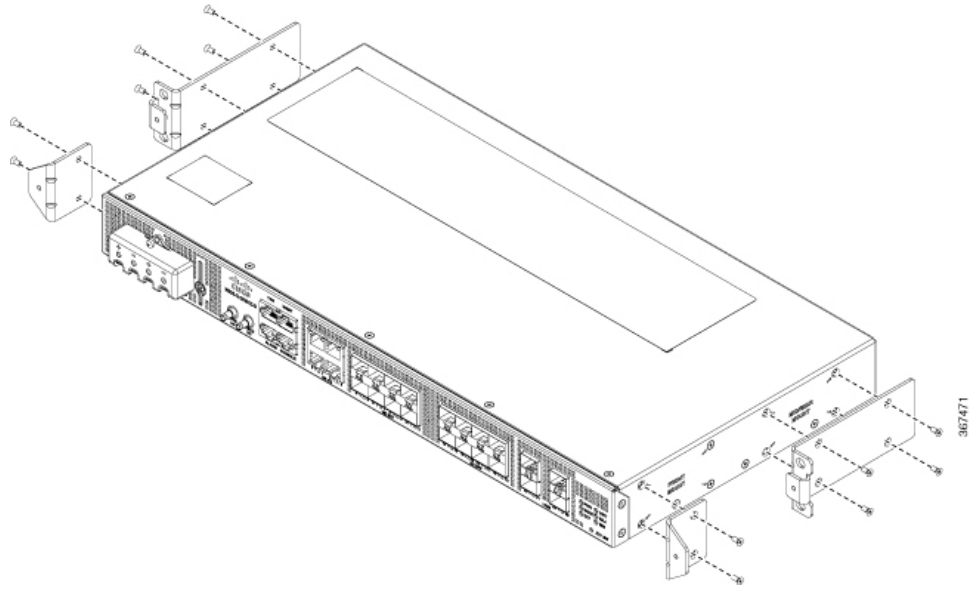
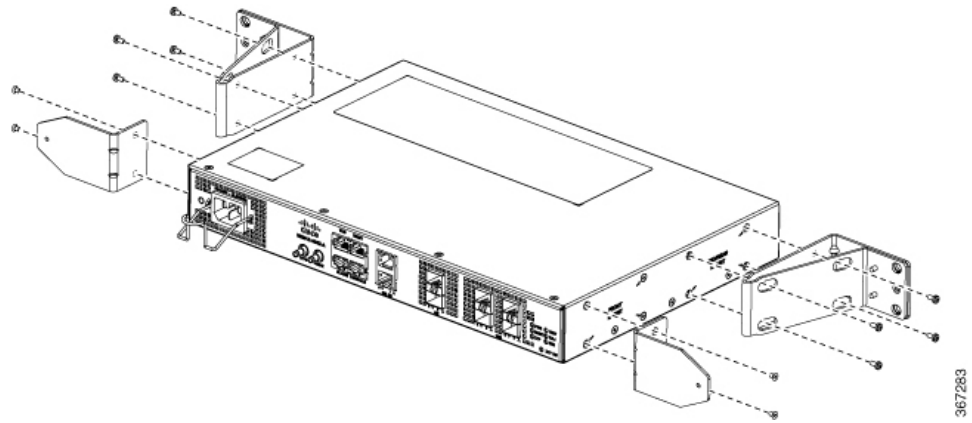
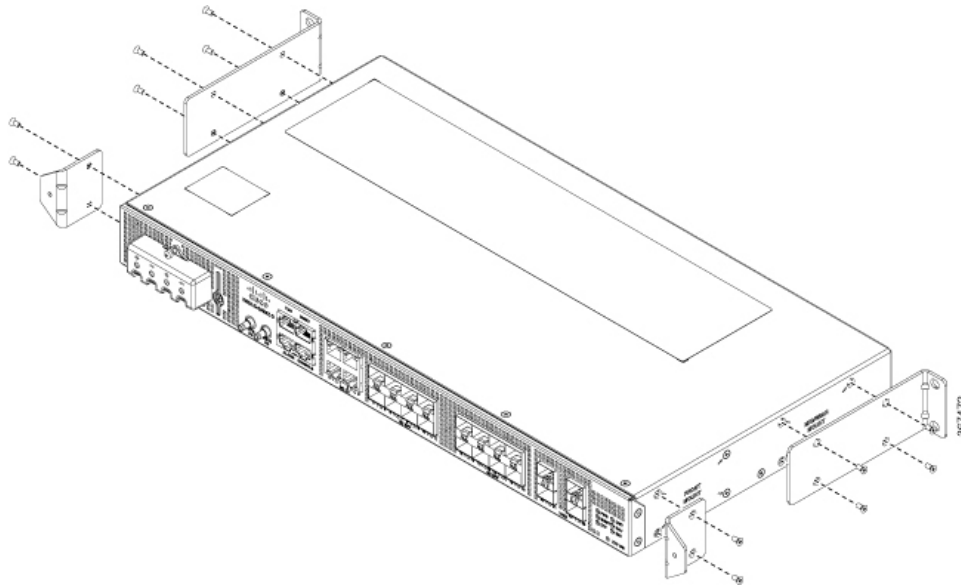

Figure 14: Rear Mount Bracket





- Step 2** Secure the bracket to the device with the recommended maximum torque of 10 inch-pounds (1.1 newton meters).

Set up Device on Rack



Note Ensure adequate clearance when mounting the device on a rack.



Note Install cable guides before installing the device in a 19 inches (48.3 centimeters) EIA rack.

Table 6: Cable Guide Bracket

N520-CBL-BRKT		
Cable Guide Bracket	700-116702-01	700-116637-01
	N520-X-4G4Z-A	N520-X-20G4Z-A
	N520-4G4Z-A	N520-20G4Z-A
	N520-X-4G4Z-D	N520-X-20G4Z-D
	Not Applicable	N520-20G4Z-D

Procedure

- Step 1** Position the cable guide-left and cable guide-right against the front of the device, and align the four screw holes as shown in the figure.
- Step 2** Secure the cable guides with four M6x12mm screws that are supplied with the cable kit. The recommended maximum torque is 26 inch-pounds (3 newton meters).
- Step 3** Position the device on the rack, and use the images as a guide to set up the device.

Figure 15: Front Mount Bracket with Cable Guide

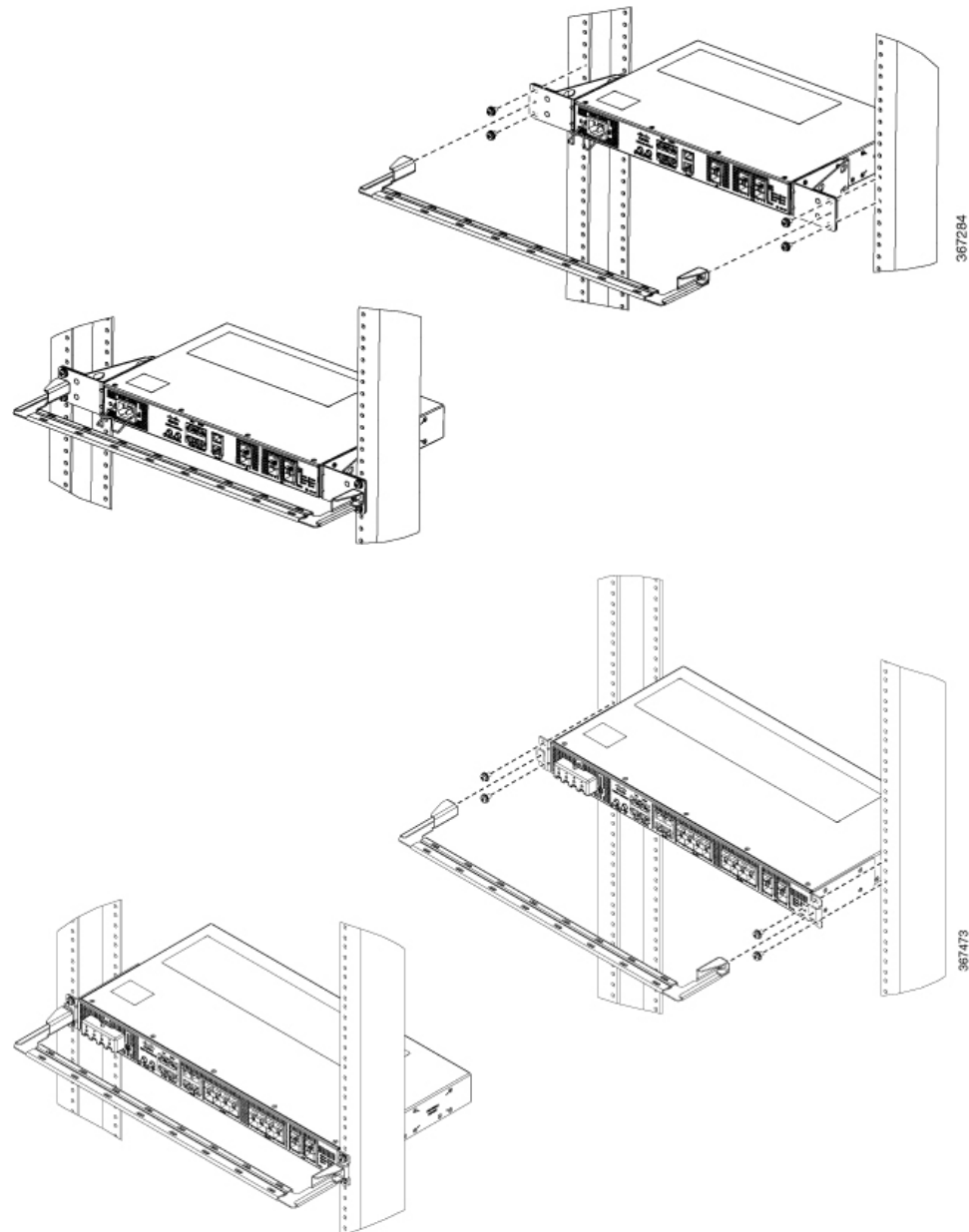

Figure 16: Middle Mount Bracket with Cable Guide

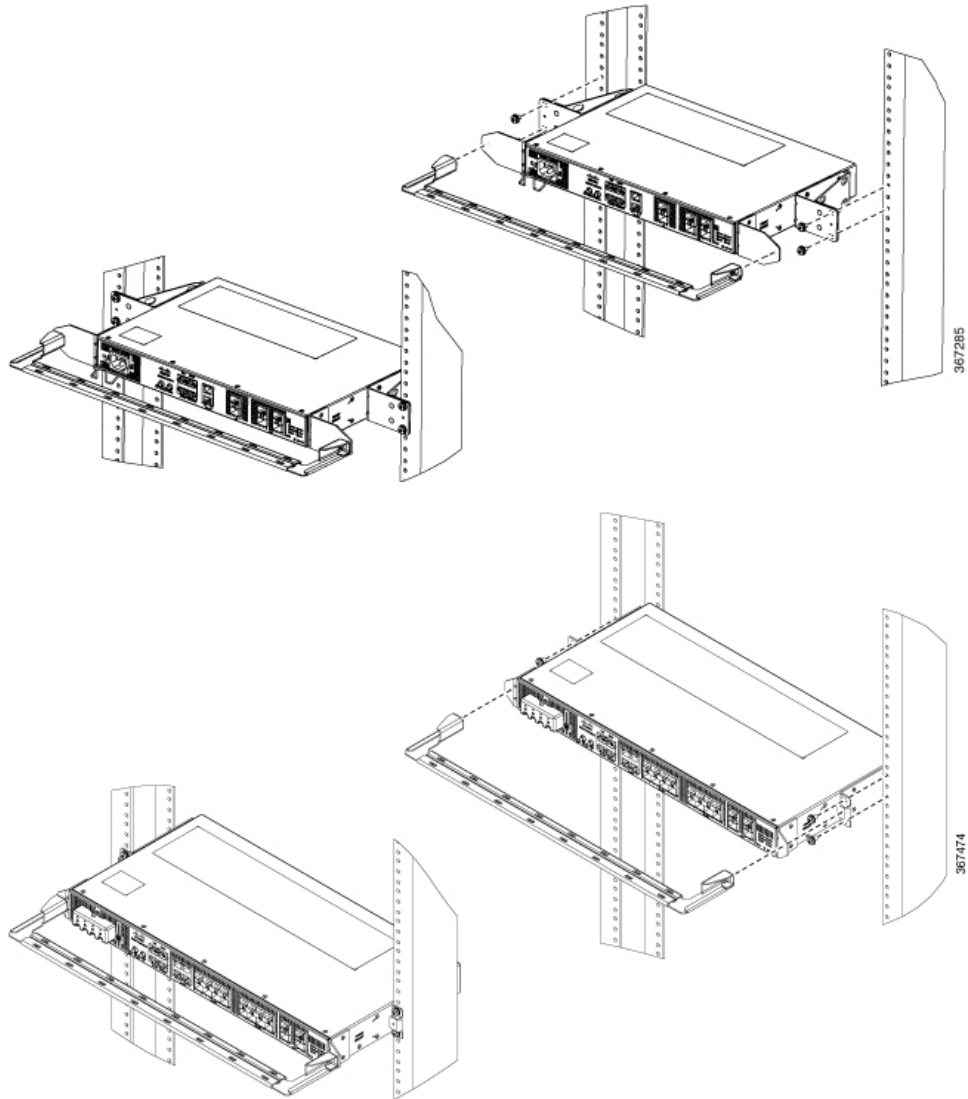
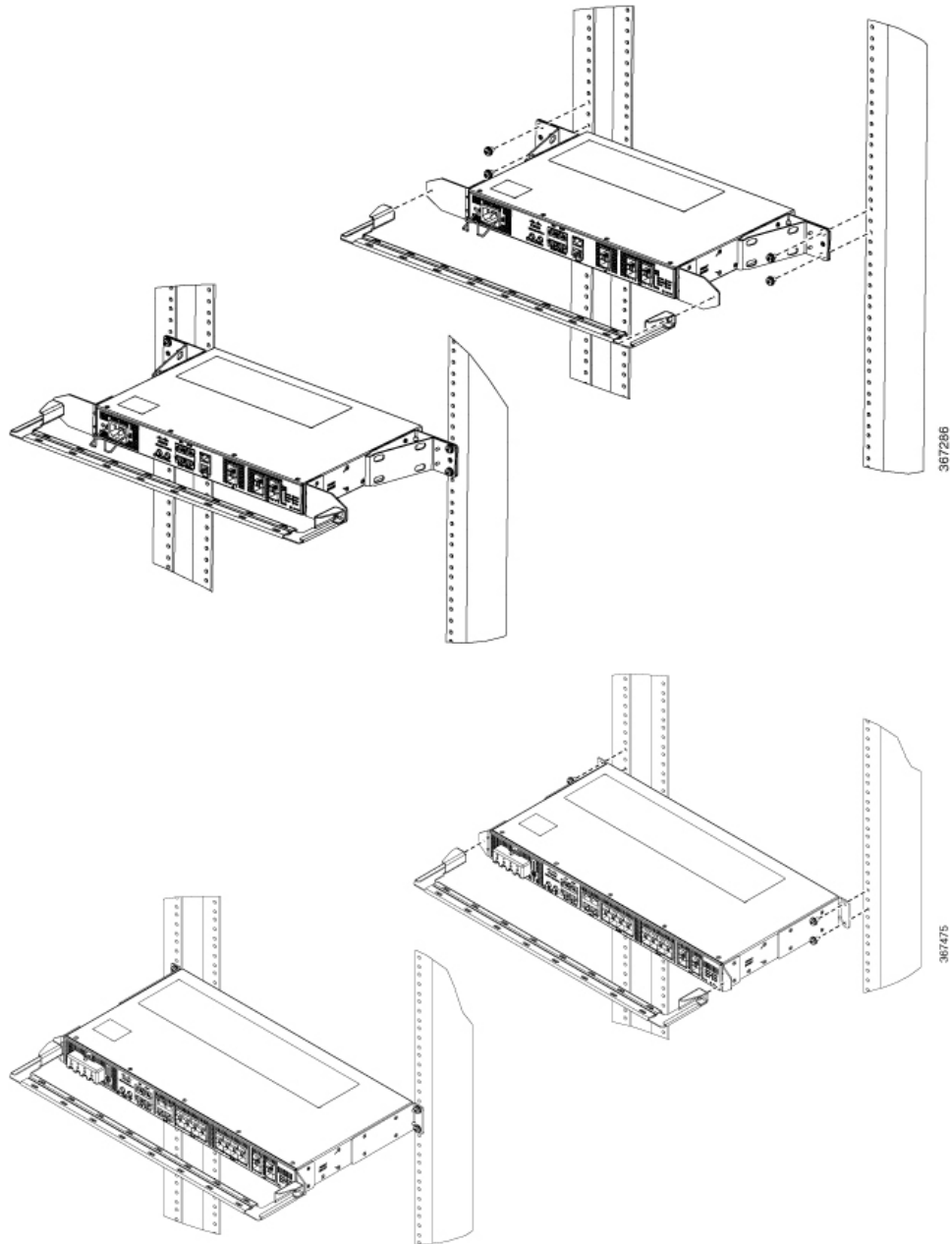

Figure 17: Rear Mount Bracket with Cable Guide



Step 4 Use a tape measure and level to verify that the device is installed straight and on level.

Wall Mount

Install the wall mounting brackets and cable guides on to the chassis before you mount the chassis on the wall.

Install Wall Brackets

The device is shipped with wall mounting brackets that are to be secured on the sides of the device.

Procedure

Step 1 Remove the wall mounting brackets from the accessory kit and position them beside the device.

Note You can install the brackets as shown in the figure.

Figure 18: Wall Mount Bracket

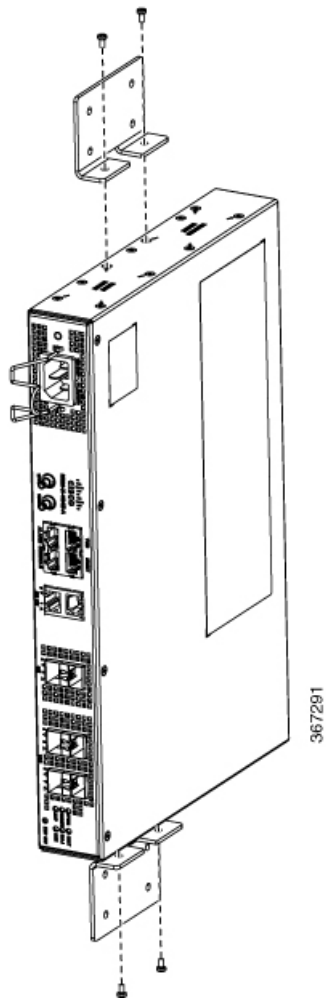

- Step 2** Secure the bracket to the device with the recommended maximum torque of 10 inch-pounds (1.1 newton meters).

Wall Mount the Device



Note Install cable guides before mounting the device on the wall.

Procedure

- Step 1** Position the cable guide against the front of the device, and align the four screw holes as shown in the figure.
- Step 2** Secure the cable guides with four M6x12mm screws that are supplied with the cable kit. The recommended maximum torque is 26 inch-pounds (3 newton meters).
- Step 3** Position the device vertically on the wall.

Note Ensure that the power supplies are positioned at the top of the device.

Figure 19: Wall Mount the Device

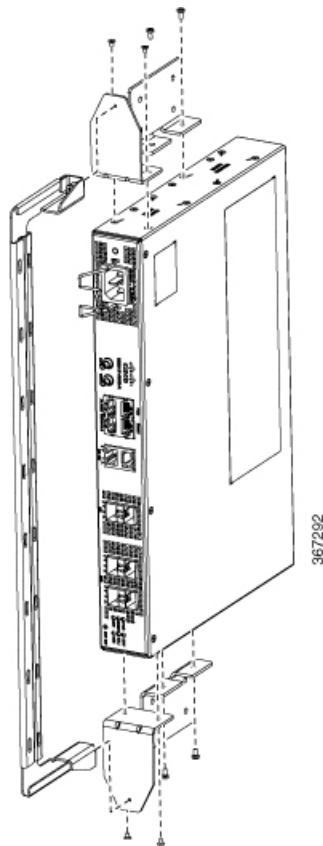

Caution Before mounting the device, ensure that all unused holes at the sides of the device are protected with screws.

Step 4 Use a tape measure and level to verify that the device is installed straight and on level.

Desktop Mount



Note Desktop mount is supported on only the N520-4G4Z-A variant.

Procedure

Step 1 Attach the four adhesive rubber feet (included in the accessory kit) to the bottom of the device.

Step 2 Set the device on a flat surface near a power source and ensure at least 2 inches (5.1 centimeters) space on all sides for proper airflow.

Ground the Device

Before you begin this task, ensure that you have read and understood the safety warnings in the [Preventing ESD Damage](#) section of the [Safety Warnings](#) handout topic.

Before you connect the power or turn on the power to the device, you must provide an adequate device ground (earth) connection to your device.

This section describes how to ground the device. The grounding lug location is on the back panel of the device.



Tip Ensure that the grounding lug wire does not cover the fan opening.

Figure 20: Attaching a Grounding Lug to the Rear of the Device

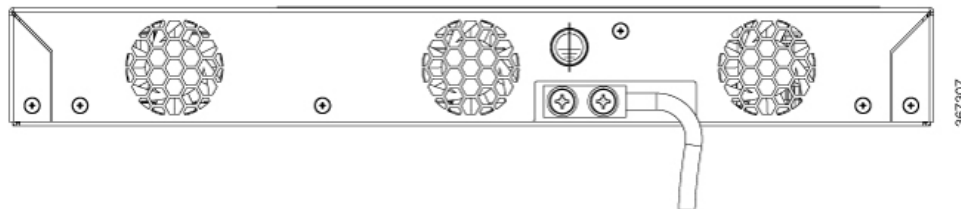

Caution To prevent personal injury or damage to the chassis, before making connections to the device, ensure that you disconnect the power at the circuit breaker.

Verify your carrier's requirements for grounding. This unit must be installed in a restrictive access location and must be permanently grounded to a minimum 6-AWG copper ground wire.

Procedure

- Step 1** If your ground wire is insulated, use a wire-stripping tool to strip the ground wire to 0.5 inch (12.7 millimeters) \pm 0.02 inch (\pm 0.5 millimeters).

Figure 21: Stripping a Ground Wire

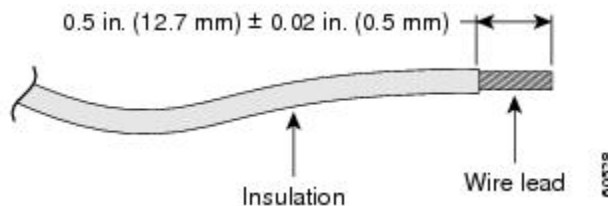

- Step 2** Slide the open end of the 2-hole ground lug over the exposed area of the ground wire.
- Step 3** Using a crimping tool (the one specified by the ground lug manufacturer), crimp the ground lug to the ground wire.
- Step 4** Use a Phillips head screwdriver to attach the 2-hole ground lug and wire assembly to the device with the 2 pan-head Phillips head screws.
- Step 5** Connect the other end of the ground wire to a suitable grounding point at your site.
-

Connect Power Cables

Before you begin this task, ensure that you have read and understood the safety warnings in the [Safety with Electricity](#) section of the [Safety Warnings](#) handout topic.

The Cisco NCS 520 supports both AC and DC power supplies. Based on your device power supply, attach the AC or the DC power cables.

Install AC Power Cable

Procedure

- Step 1** Attach the AC power retainer chord.

Figure 22: Attach the AC Power Retainer Chord

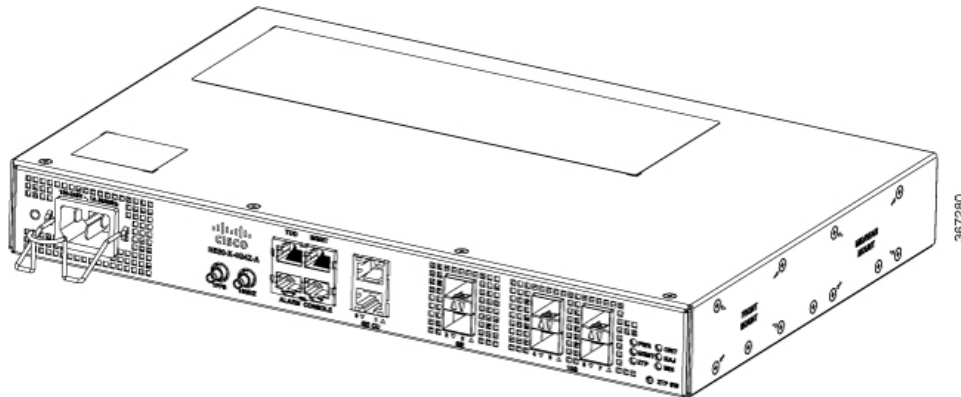

- Step 2** Lift the power retainer and plug in the AC power supply.
-

Activate AC Power Supply

Procedure

- Step 1** Plug the power cord into the power supply.
- Step 2** Connect the other end of the power cord to an AC-input power source.
- Step 3** Verify the power supply operation by ascertaining that the front panel LED is green.
- Step 4** If the LEDs indicate a power problem, see the *Troubleshooting Aids* chapter.
- Step 5** If you are also connecting a redundant AC power supply, repeat these steps for the second power source.

Note When you connect a redundant AC power supply, ensure that each power supply is connected to a separate power source to prevent power loss during failure.

Install DC Power Cable



Note When installing DC power supply cables, use 14 AWG, 90°C wires. Always ensure that the building's installation for short-circuit (overcurrent) protection does not exceed 15 A.



Note The DC connector or terminal block has an inbuilt screw and cage nut to which a torque of 1.3 to 1.8 newton meters may be applied.

Figure 23: DC Connector with Inbuilt Screw

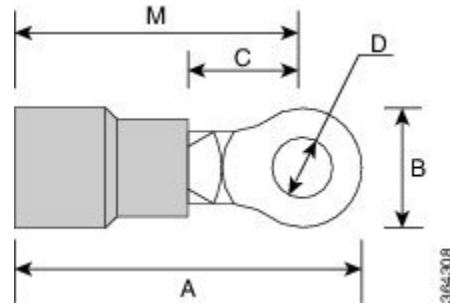

A	0.97 inches (2.4 centimeters)	C	0.27 inches (0.68 centimeters)
B	0.31 inches (0.78 centimeters)	D	0.17 inches (0.43 centimeters)
M	0.81 inches (2 centimeters)		

Procedure

- Step 1** Open the DC power supply guard.
- Step 2** Attach the DC supply wires to the designated screws.

Figure 24: Attach DC Power Chord

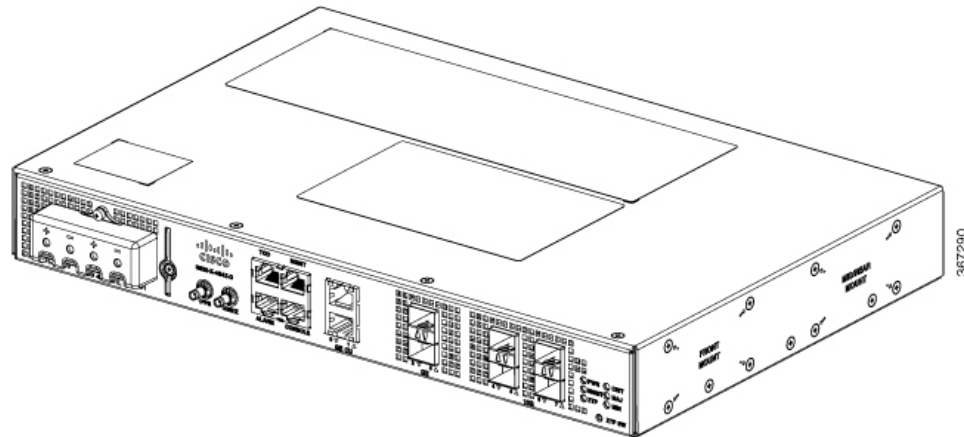

- Step 3** Close the DC power supply guard.

Activate DC Power Supply

Procedure

- Step 1** Remove the tape from the circuit-breaker device handle, and restore power by moving the circuit-breaker device handle to the On (I) position.

- Step 2** Verify the power supply operation by ascertaining that the front panel LED is green.
- Step 3** If the LEDs indicate a power problem, see the *Troubleshooting Aids* chapter.
- Step 4** If you are also connecting a redundant DC power supply, repeat these steps for the second power source.
- Note** When you connect a redundant DC power supply, ensure that each power supply is connected to a separate power source to prevent power loss during a failure.
-

Connect Gigabit Ethernet Ports

Gigabit Ethernet (GE) ports can be connected to other devices using either fiber optic or copper cables. The choice depends on whether the communication distance between your devices is long or short.

If you choose fiber optic cables, connect suitable Small Form-factor Pluggable (SFP) modules. The device supports various SFP and SFP+ modules, including optical and Ethernet modules. For information on how to install and remove SFP and SFP+ modules, see the documentation for the SFP or SFP+ module at: [Cisco SFP and SFP+ Transceiver Module Installation Notes](#). Select the port on the device where you insert the SFP module.

If you choose copper cables, connect to an RJ-45 connector.

The device 10/100/1000 ports configure themselves to operate at the speed of devices to which they are connected. By default, autonegotiation is enabled in the chassis. You can manually set the speed and the duplex parameters. If the device to which the ports are connected does not autonegotiate, low performance or no linkage may result.

To maximize performance, choose one of these methods for configuring the GE ports:

- Have ports autonegotiate both speed and duplex parameters.
- Set speed and duplex parameters on both ends of the connection.

Use the **mdix auto** command in the interface configuration mode to enable an automatic media-dependent interface with crossover detection. After you enable the automatic media-dependent interface, the device detects the required cable type for copper Ethernet connections and configures the interface accordingly. Then, use either a crossover or a straight-through cable for connecting to a copper 10/100/1000 port. If the **mdix auto** command fails to enable the interface, connect the cable through SFP modules.

Connect SFP Modules

Before you begin this task, ensure that you have read and understood the safety warnings in the [Safety Precautions for Module Installation and Removal](#) section of the [Safety Warnings](#) handout topic.

Use only Cisco SFP modules on a Cisco device. Each SFP module has an internal serial EEPROM that is encoded with security information. This encoding provides a way for Cisco to identify and validate that the SFP modules meet the requirements of the device.



Caution We recommend that you wait for 30 seconds between the removal and insertion of an SFP module from the device. The wait period allows the transceiver software to initialize and synchronize with the device. Changing an SFP before this wait period could result in transceiver initialization issues that disable the SFP.

This section provides procedures for installing and connecting SFP modules. Also, it provides the procedure for removing SFP modules.

Install SFP Modules



Caution We strongly recommend that you do not install (or remove) an SFP module with its cables connected because of the potential damage that may be caused to the cables, the cable connector, or the optical interfaces in the SFP modules. Disconnect all cables before removing or installing an SFP module.

Removing and installing an SFP module can shorten its useful life. Do not remove and insert SFP modules unless necessary.

The following figure shows an SFP module that has a bale-clasp latch.

Figure 25: SFP Module with Bale-Clasp Latch

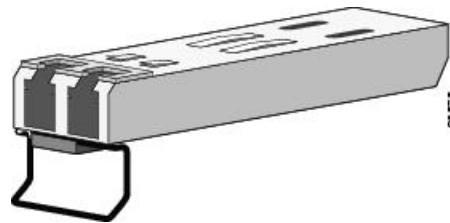

Some SFP modules identify the top side of the module with send (TX) and receive (RX) markings or arrows that show the direction of the connection. If the SFP module that you are using has such markings, use them to identify the top of the module.

Procedure

-
- Step 1** Attach an ESD-preventive wrist strap to your wrist and to a bare metal surface on the chassis.
- Step 2** Align the SFP module at the front of the slot opening.
- Step 3** Insert the SFP module into the slot until the connector on the module snaps into place at the rear of the slot.
- Caution** Do not remove the dust plugs from the fiber-optic SFP module port or the rubber caps from the fiber-optic cable until you are ready to connect the cable. The plugs and caps protect the SFP module ports and cables from contamination and ambient light. Store the dust plugs for later use.
- Step 4** Insert the appropriate cable connector into the SFP module:
- For fiber-optic SFP modules, insert the LC cable.
 - For copper 1000BASE-T SFP modules, insert the RJ-45 cable.
-

Remove SFP Modules

Follow these steps to remove an SFP module when it is necessary.

Procedure

- Step 1** Attach an ESD-preventive wrist strap to your wrist and to a bare metal surface on the chassis.
- Step 2** Disconnect the cable from the SFP module, and insert a dust plug into the cable end.
- Step 3** Unlock and remove the SFP module.
- If the module has a bale-clasp latch, pull the bale down and out to eject the module. If the bale-clasp latch is obstructed, use a small, flat-blade screwdriver or any other narrow instrument to open the bale-clasp latch.
- Step 4** Grasp the SFP module between your thumb and index finger, and carefully remove it from the module slot.
- Step 5** For fiber-optic SFP modules, insert a dust plug into the optical ports of the SFP module to keep the optical interfaces clean.
- Step 6** Place the removed SFP module in an antistatic bag or other protective environment.
- For information about inspecting and cleaning fiber-optic connections, see: [Inspection and Cleaning Procedures for Fiber-Optic Connections](#).
-

Connect Fiber Optic SFP Modules



- Caution** Do not remove the rubber plugs from the SFP module port or from the fiber optic cable until you are ready to connect the cable. The plugs and caps protect the SFP module ports and cables from contamination and ambient light.
-

Procedure

- Step 1** Remove the rubber plugs from the module port and fiber optic cable, and store them for future use.
- Step 2** Insert one end of the fiber optic cable into the SFP module port.
- Step 3** Insert the other end into a fiber optic connector at a target device.
- Step 4** Observe the port's LED status.
- The LED turns green when the device and the target device establish a link.
- If the LED is off, check whether the target device is turned on, or whether there is any failure in the target device.
- Step 5** If necessary, reconfigure and restart the device or target device.
-

Connect RJ-45 Connector

Procedure

- Step 1** To connect to workstations, servers, and devices, connect a straight-through cable to an RJ-45 connector at the front panel.
- When connecting to devices or repeaters, use a crossover cable.
- Step 2** Connect the other end of the cable to an RJ-45 connector at the other device. The port's LED turns on when both the device and the connected device have established a link.
- If the port LED does not turn on, check whether the device at the other end is turned on or whether there is any failure.
- Note** On user network interface (UNI) ports, the port LED turns green after the link is established.
- Step 3** Reconfigure and reboot the connected device if necessary.
- Step 4** Repeat Steps 1 to 3 for each device that is to be connected.
-

Connect Chassis to Network



Note Connect only SELV services to all the device ports.

Connect to EIA Console Port



Note The serial console cable kit is not included with the device; it must be ordered separately.

Procedure

- Step 1** Connect the RJ-45 cable to the EIA Console port.
- Step 2** Connect the DB-9 end of the console cable to the DB-9 end of the terminal.
- Step 3** To communicate with the device, start a terminal emulator application, such as Microsoft Windows Hyper-Terminal. Configure the software with the following parameters:
- 9600 baud
 - 8 data bits
 - No parity
 - 1 stop-bit

- No flow control
-

Connect a Management Ethernet Cable

When using the Ethernet Management port in the default mode (speed-auto and duplex-auto), the port operates in the auto-MDI/MDI-X mode. The port automatically provides the correct signal connectivity through the Auto-MDI/MDI-X feature, and senses a crossover or straight-through cable and adapts to it.

However, the Ethernet Management port may be configured to a fixed speed (10, 100, or 1000 Mbps) through command-line interface (CLI) commands. In such a case, the port is forced to operate in the MDI mode.

When in a fixed-speed configuration and MDI mode, use:

- a crossover cable to connect to an MDI port
- a straight-through cable to connect to an MDI-X port

Connect Cable to Copper Gigabit Ethernet Port

The device interface modules support RJ-45 and Ethernet SFP ports.

The RJ-45 port supports standard straight-through and crossover Category 5 unshielded twisted-pair (UTP) cables. Cisco does not supply Category 5 UTP cables. These cables are available commercially.

Procedure

- Step 1** Confirm that the device is powered off.
 - Step 2** Connect one end of the cable to the Gigabit Ethernet port on the device.
 - Step 3** Connect the other end to the BTS patch or demarcation panel at your site.
-

You have successfully installed the device and you are now ready to carry out a basic device configuration.



CHAPTER 5

Configure the Device

Before you begin this task, ensure that you have read and understood the safety warnings in the [Safety with Electricity](#) section of the [Safety Warnings](#) handout topic.

Configuring the Cisco NCS 520 involves these tasks:

- [Power up the Device, on page 45](#)
- [Configure Device at Startup, on page 46](#)
- [Safely Power Down the Device, on page 49](#)

Power up the Device

After installing your device and connecting cables, start the device with these steps:



Caution

Do not press any keys on the keyboard until the messages stop appearing, and the PWR LED becomes solid green. Any key that is pressed during this time is interpreted as a command to be executed when the messages stop. That action results in getting the device to power off and start over. It takes a few minutes for the messages to stop appearing.

Procedure

Step 1 Switch on the power supply.

Step 2 Observe the system LEDs to monitor the initialization process.

When the system boot is complete (the process takes a few seconds), the device begins to initialize. After the device has booted, the green PWR LED comes and stays on.

Verify the Front Panel LEDs

The front-panel indicator LEDs provide power, activity, and status information useful during bootup. For more detailed information about the LEDs, see the *LED Indicators* section.

Verify the Hardware Configuration

To display and verify the hardware features, enter the following commands:

Table 7: Hardware Commands

Command	Description
show version	Displays the following information: <ul style="list-style-type: none"> • system hardware version • software version installed • configuration file names and source • boot image • DRAM space • NVRAM space • flash memory space
show diag slot	Displays IDPROM information for the assemblies in the device.

Check Hardware and Software Compatibility

To check the minimum software requirements of the Cisco IOS software, login to the Software Advisor tool at cisco.com. The tool provides the Cisco IOS minimum requirements for individual hardware modules and components.



Note To access this tool, you must have a cisco.com login credentials.

To access Software Advisor:

1. Click **Log In** at cisco.com.
2. Type your registered Username and Password and click **Log In**.
3. Type **Software Advisor** in the search box, and click the search icon.
4. From the displayed search result, select the Software Advisor Tool link.
5. Choose a product family or enter a specific product number to search for the minimum supported software that is needed for your hardware.

Configure Device at Startup

This section explains how to create a basic running configuration for your device.



Note Acquire the correct network addresses from your system administrator or consult your network plan before you create the basic running configuration.

Before continuing the configuration process, check the current state of the device by entering the **show version** command. This command displays the Cisco IOS software release that is available on the device.

For information on modifying the configuration you create, see the [Cisco IOS Master Command List, All Releases](#).

To configure a device from the console, you must connect a terminal or terminal server to the console port on the device. To configure the device using the management Ethernet port, you must have the device's IP address.

Access the CLI Using the Console

Procedure

Step 1 When your system is booting, enter *no* at the prompt.

Example:

```
--- System Configuration Dialog ---  
Would you like to enter the initial configuration dialog? [yes/no]: no
```

Step 2 Press Return to enter the user EXEC mode.

The following prompt is displayed:

```
Router>
```

Step 3 From the user EXEC mode, enter the enable command:

```
Router> enable
```

Step 4 At the password prompt, enter your system password (if a password has not been set on your system, you can skip this step.)

```
Password: enablepass
```

When your password is accepted, the privileged EXEC mode prompt is displayed:

```
Router#
```

You now have access to the CLI in privileged EXEC mode. You can enter necessary commands to complete required tasks.

Step 5 To exit the console session, enter the quit command:

```
Router# quit
```

Configure Global Parameters

When you first start the setup program, configure certain global parameters that are used for controlling system-wide settings. Perform the following steps to enter the global parameters:

Procedure

Step 1 Connect a console terminal to the console port, and then boot the device.

Note The following is only an example of the output display; prompts may vary.

When this information appears, it means that you have successfully booted your device:

Example:

```
Restricted Rights Legend
```

```
Use, duplication, or disclosure by the Government is
subject to restrictions as set forth in subparagraph
(c) of the Commercial Computer Software - Restricted
Rights clause at FAR sec. 52.227-19 and subparagraph
(c) (1) (ii) of the Rights in Technical Data and Computer
Software clause at DFARS sec. 252.227-7013.
```

```
cisco Systems, Inc.
170 West Tasman Drive
San Jose, California 95134-1706
```

```
.
.
.
```

```
--- System Configuration Dialog ---
```

```
Would you like to enter the initial configuration dialog? [yes/no]: yes
```

```
Press RETURN to get started!
```

Step 2 The first sections of the configuration script appear only at an initial system startup. On subsequent uses, the script begins with a System Configuration Dialog as shown below. When prompted to enter the initial configuration dialog, enter *yes*.

```
Would you like to enter the initial configuration dialog? [yes/no] yes
```

```
At any point you may enter a question mark '?' for help.
Use ctrl-c to abort configuration dialog at any prompt.
Default settings are in square brackets '[]'.
```

```
Basic management setup configures only enough connectivity for management of the system,
extended setup will ask you to configure each interface on the system.
```

The basic management setup configures enough connectivity for managing the system; the extended setup prompts you to configure each interface on the system.

Check the Running Configuration Settings

To view the value of the settings you have entered, enter the following command in privileged EXEC mode:

```
device# show running-config
```

To review the changes you have made to the configuration, enter the following command in EXEC mode and copy run-start stored in the NVRAM.

```
device# show startup-config
```

Save the Running Configuration to NVRAM

To store the configuration or changes to your startup configuration in NVRAM, enter the following command at the prompt:

```
device# copy running-config startup-config
```

This command saves the configuration settings that you create in the device using the configuration mode and the setup facility. If the save action fails, you lose your configuration, and it is not available during your next reload.

Safely Power Down the Device

This section explains how to shut down the device. We recommend that before turning off all power to the device, you issue the **reload** command. Running this command ensures that, the operating system cleans up all file systems. After the reload operation is complete, the device can be powered down safely.

To power down the device safely:

Procedure

- Step 1** Slip on the ESD-preventive wrist strap included in the accessory kit.
 - Step 2** Enter the **reload** command.
 - Step 3** Click the **Enter** key when prompted to confirm.
 - Step 4** Wait for the system bootstrap message before powering down the system:
 - Step 5** Remove power cables, if any, from the device:
 - For power supplies with a circuit breaker switch, position the switch to the 'Off' (O) position.
 - For power supplies with a standby switch, place the standby switch in the 'Standby' position.
-

After powering down the device, wait for a minimum of 30 seconds before powering it on again.



CHAPTER 6

Troubleshooting Aids

Certain troubleshooting aids of the Cisco NCS 520 enable you to perform these tasks that assist the troubleshooting process:

- [Verify Pinout, on page 51](#)
- [Check Optical Fiber Specifications, on page 52](#)
- [Check Alarm Conditions, on page 53](#)
- [Check LED Indicators, on page 53](#)

Verify Pinout

Pinouts provide input signal (to the device) and output signal (from the device) information. Time-of-Day Port (TOD) port, Alarm (ALARM) port, and Management Ethernet (MGMT) port pinout information is provided in the following sections.

Time-of-Day Port Pinouts

The following table summarizes the ToD/1-PPS port pinouts.

Table 8: RJ-45 1PPS/ToD Port Pinouts

Pin	Signal Name	Direction	Description
1	RESERVED	Output	Do Not Connect
2	RESERVED	Input	Do Not Connect
3	1PPS_N	Output or Input	1PPS RS422 signal
4	GND	—	—
5	GND	—	—
6	1PPS_P	Output or Input	1PPS RS422 signal
7	TOD_N	Output or Input	Time-of-Day character
8	TOD_P	Output or Input	Time-of-Day character

Alarm Port Pinouts

The following table summarizes the external alarm input pinouts.

Table 9: External Alarm Input Pinouts

Pin	Signal Name	Description
1	ALARM0_IN	Alarm input 0
2	ALARM1_IN	Alarm input 1
3	—	No connect
4	ALARM2_IN	Alarm input 2
5	ALARM3_IN	Alarm input 3
6	—	No connect
7	—	No connect
8	COMMON	Alarm common

Management Ethernet Port Pinouts

The following table summarizes the Management Ethernet port pinouts.

Table 10: Fan Alarm Port Pinout

Pin	Signal Name
1	TRP0+
2	TRP0-
3	TRP1+
4	TRP2+
5	TRP2-
6	TRP1-
7	TRP3+
8	TRP3-

Check Optical Fiber Specifications

Optical fiber transmission defines two types of fiber specification:

- Single mode with three transmission types: short reach, intermediate reach, and long reach.
- Multimode with only short reach.

Check Alarm Conditions

The following table summarizes the meaning of alarm conditions on the device.

Table 11: Alarm Conditions Summary

Alarm Type	Alarm Meaning
Critical	Port in down state. Environmental sensor threshold exceeded critical level (voltage, temperature).
Major	Environmental sensor threshold exceeded major level (voltage, temperature).
Info	Port is administratively shut down.

Check LED Indicators

This section describes the different types of front panel LEDs and their behavior.

Power LED

The PWR LED provides power on the board and the overall health status of the device. During the power-up state, the LED provides booting status and report errors.



Note The digital code signing functionality validates the integrity and authenticity of the ROMMON image before booting it.

Table 12: Power LED Indication

LED State	Indication
Green	Board that is powered up, IOS Booted and running
Blinking Green	Bootloader is up
Red	Failure to boot or CPU is in reset
Off	No power

CPU Management Port LEDs

A bicolor LED indicates the status of the management port. The following table gives definition of the MGMT LED indication.

Table 13: CPU Management Port LED Indication

LED	LED State	Indication
MGMT	Green	Link up in 1000 Mbps
	Blinking Green	Activity in 1000 Mbps
	Amber	Link up in 10/100 Mbps
	Blinking Amber	Activity in 10/100 Mbps

SFP+ LEDs

Each port in sets of GE SFP+ ports has an LED indicator.

Table 14: SFP+ Port LED Indication

LED	LED State	Indication
GE / GE SFP	Green	Link up in 10G/1G
	Blinking Green	Activity in 10G/1G
	Yellow	Fault/Error/Link down
	Off	Admin down

Copper GE Ports

The copper GE ports have two status LEDs each. The copper PHY drives these LEDs.

Table 15: Copper GE Port LED Indication

LED State	Indication (LED on the left)	Indication (LED on the right)
Green	Link up in 1G mode.	Link up in full-duplex mode.
Blinking Green	Activity in 1G mode	-
Yellow	Fault or Error	-

LED State	Indication (LED on the left)	Indication (LED on the right)
Off	Link administratively down	Link up in half-duplex.

Alarm LED

The Alarm port has 3 corresponding LEDs. These LEDs are based on the severity of the alarm condition: CRIT (critical), MAJ (major), and MIN (minor).

Table 16: Alarm LEDs

LED State	CRIT	MAJ	MIN
Off	No alarm		
Red	PSU redundancy failure (for redundant systems) One or more thermal sensors have crossed Critical alarm threshold	-	System in holdover or free-run mode (applicable only on premium devices)
	More than one fan failure	Single fan failure	-
	Optics temperature crossing thresholds		

