

**SAMSUNG**

# INSTALL GUIDE

---

**UHD TV**

HG43RU710N HG50RU710N HG55RU710N  
HG65RU710N  
HG43RU750N HG50RU750N HG55RU750N  
HG65RU750N HG75RU750N

Thank you for purchasing this Samsung product.

To receive more complete service, please register your product at [www.samsung.com](http://www.samsung.com)

Model \_\_\_\_\_ Serial No. \_\_\_\_\_

# Before Reading This Install Guide

This TV B2B (Business to Business) model is designed for hotels or the other hospitality businesses, supports a variety of special functions, and lets you limit some user (guest) controls.

Figures and illustrations in this Install Guide are provided for reference only and may differ from the actual product appearance. Product design and specifications may change without notice.

## Operational Modes

This TV has two modes: **Interactive** and **Standalone** mode.

- **Interactive** mode: In this mode, the TV communicates with and is fully or partially controlled by a connected Set Back Box (SBB) or Set Top Box (STB) provided by a hospitality System Integration (SI) vendor. When the TV is initially plugged in, it sends a command that attempts to identify the SBB or STB connected to it. If the TV identifies the SBB or STB and the SBB or STB identifies the TV, the TV gives full control to the SBB or STB.
- **Standalone** mode: In this mode, the TV works alone without an external SBB or the STB.

The TV has a **Admin menu** that lets you easily set its various hospitality functions. Please see page 28.

The menu also lets you activate or de-activate some TV and hospitality functions so you can create your optimal hospitality configuration.

## Still image warning







Avoid displaying still images (such as jpeg picture files) or still image elements (such as TV channel logos, panorama or 4:3 format images, stock or news bars or crawls) on the screen. Displaying still pictures continually can cause uneven screen wear, which will affect image quality. To reduce the chance that this effect will occur, please follow the recommendations below:

- Avoid displaying the same TV channel for long periods.
- Always try to display a full screen image.
- Reduce brightness and contrast to help prevent the occurrence of after-images.
- Use all TV features designed to reduce image retention and screen burn-in.

# Warning! Important Safety Instructions

Please read the Safety Instructions before using your TV.

Refer to the table below for an explanation of symbols which may be on your Samsung product.

CAUTION			Class II product: This symbol indicates that a safety connection to electrical earth (ground) is not required. If this symbol is not present on a product with a power cord, the product <b>MUST</b> have a reliable connection to protective earth (ground).
<b>RISK OF ELECTRIC SHOCK. DO NOT OPEN.</b>			
CAUTION: TO REDUCE THE RISK OF ELECTRIC SHOCK, DO NOT REMOVE COVER (OR BACK). THERE ARE NO USER SERVICEABLE PARTS INSIDE. REFER ALL SERVICING TO QUALIFIED PERSONNEL.			AC voltage: Rated voltage marked with this symbol is AC voltage.
	This symbol indicates that high voltage is present inside. It is dangerous to make any kind of contact with any internal part of this product.		DC voltage: Rated voltage marked with this symbol is DC voltage.
	This symbol indicates that this product has included important literature concerning operation and maintenance.		Caution. Consult instructions for use: This symbol instructs the user to consult the install guide for further safety related information.

- The slots and openings in the cabinet and in the back or bottom are provided for necessary ventilation. To ensure reliable operation of this apparatus and to protect it from overheating, these slots and openings must never be blocked or covered.
  - Do not place this apparatus in a confined space, such as a bookcase or built-in cabinet, unless proper ventilation is provided.
  - Do not place this apparatus near or over a radiator or heat register, or where it is exposed to direct sunlight.
  - Do not place vessels (vases etc.) containing water on this apparatus, as this can result in a fire or electric shock.
- Do not expose this apparatus to rain or place it near water (near a bathtub, washbowl, kitchen sink, or laundry tub, in a wet basement, or near a swimming pool, etc.). If this apparatus accidentally gets wet, unplug it and contact an authorized dealer immediately.
- This apparatus uses batteries. In your community, there might be environmental regulations that require you to dispose of these batteries properly. Please contact your local authorities for disposal or recycling information.
- Do not overload wall outlets, extension cords, or adaptors beyond their capacity, since this can result in fire or electric shock.
- Power-supply cords should be placed so that they are not likely to be walked on or pinched by items placed upon or against them. Pay particular attention to cords at the plug end, at wall outlets, and at the point where they exit from the appliance.
- To protect this apparatus from a lightning storm, or when left unattended and unused for long periods of time, unplug it from the wall outlet and disconnect the antenna or cable system. This will prevent damage to the set due to lightning and power line surges.

- Before plugging in the AC power cord of the TV, make sure that the operational voltage of the TV matches the voltage of your local electrical power supply. Refer to the power specifications section of the manual and/or the power supply label on the product for voltage and amperage information.
- Never insert anything metallic into the open parts of this apparatus. This may cause a danger of electric shock.
- To avoid electric shock, never touch the inside of this apparatus. Only a qualified technician should open this apparatus.
- Be sure to plug in the power cord until it is firmly seated. When unplugging the power cord from a wall outlet, always pull on the power cord's plug. Never unplug it by pulling on the power cord. Do not touch the power cord with wet hands.
- If this apparatus does not operate normally - in particular, if there are any unusual sounds or smells coming from it - unplug it immediately and contact an authorized dealer or service center.
- Be sure to pull the power plug out of the outlet if the TV is to remain unused or if you are to leave the house for an extended period of time (especially when children, elderly, or disabled people will be left alone in the house).
  - Accumulated dust can cause an electric shock, an electric leakage, or a fire by causing the power cord to generate sparks and heat or by causing the insulation to deteriorate.
- Be sure to contact an authorized Samsung service center for information if you intend to install your TV in a location with heavy dust, high or low temperatures, high humidity, chemical substances, or where it will operate 24 hours a day such as in an airport, a train station, etc. Failure to do so may lead to serious damage to your TV.
- Use only a properly grounded plug and wall outlet.
  - An improper ground may cause electric shock or equipment damage. (Class I Equipment only.)
- To turn off this apparatus completely, disconnect it from the wall outlet. To ensure you can unplug this apparatus quickly if necessary, make sure that the wall outlet and power plug are readily accessible.
- Store the accessories (batteries, etc.) in a location safely out of the reach of children.
- Do not drop or strike the product. If the product is damaged, disconnect the power cord and contact a Samsung service center.
- To clean this apparatus, unplug the power cord from the wall outlet and wipe the product with a soft, dry cloth. Do not use any chemicals such as wax, benzene, alcohol, thinners, insecticide, air fresheners, lubricants, or detergents. These chemicals can damage the appearance of the TV or erase the printing on the product.
- Do not expose this apparatus to dripping or splashing.
- Do not dispose of batteries in a fire.
- Do not short-circuit, disassemble, or overheat the batteries.
- There is danger of an explosion if you replace the batteries used in the remote with the wrong type of battery. Replace only with the same or equivalent type.
- **WARNING - TO PREVENT THE SPREAD OF FIRE, KEEP CANDLES AND OTHER ITEMS WITH OPEN FLAMES AWAY FROM THIS PRODUCT AT ALL TIMES.**
- Use care when touching the TV after it has been on for some time. Some parts can be warm to the touch.







# Contents

	Before Reading This Install Guide	2
	Warning! Important Safety Instructions	3
<b>01</b>	<b>Package Content</b>	
	Installing the LED TV Stand	8
	Installing the wall mount kit	10
	Securing the TV to the Wall	10
	Wall Mount Kit Specifications (VESA)	11
	Providing proper ventilation for your TV	12
<b>02</b>	<b>The Remote Control</b>	
	About the Buttons on the Remote Control	13
	Installing batteries into the remote control	15
<b>03</b>	<b>Controlling external devices with a remote control - Using the Universal Remote</b>	
	Downloading the Universal Remote icon	18
<b>04</b>	<b>Initial Setup</b>	
	Using the TV Controller	21
<b>05</b>	<b>The Connection Panel</b>	
<b>06</b>	<b>Connections</b>	
	Connecting to your Internet network	24
	Connecting the TV to a SBB or STB	26
<b>07</b>	<b>Setting the Admin Menu</b>	
	Admin menu items	29
	USB Cloning	34
	Settings Cloned in the Admin menu	35
	Setting Auto Initialize	37
	Updating the TV's Software	40

<b>08</b>	<b>Editing Channels</b>	
	Using Channel Editor	41
<b>09</b>	<b>Specifications and Other Information</b>	
	Specifications	44
	Environmental Considerations	45
	Decreasing power consumption	45
	Supported Resolutions for UHD Input Signals	46
	Supported Resolutions for Connecting a Computer	46
	Supported Resolutions for Video Signals	48
	Dimensions	49
	Licenses	53
	Important Warranty Information Regarding Television	
	Format Viewing	54
	SAMSUNG ELECTRONICS NORTH AMERICAN LIMITED WARRANTY STATEMENT	55

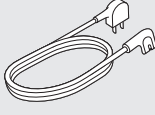
# 01 Package Content

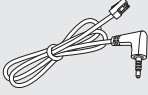
Make sure the following items are included with your TV. If any items are missing, contact your dealer.

		
Remote Control & Batteries (AAA x 2)	Power Cord	Quick Setup Guide / Regulatory Guide
		
Wall Mount Adaptor x 4	Data Cable (x 2, depending on the model)	Holder-Cable

- The items' colors and shapes may vary depending on the models.
- Cables not included can be purchased separately.
- Check for any accessories hidden behind or in the packing materials when opening the box.



The screen can be damaged from direct pressure when handled incorrectly. As shown in the figure, make sure to grip the edges of the screen when you lift the TV.

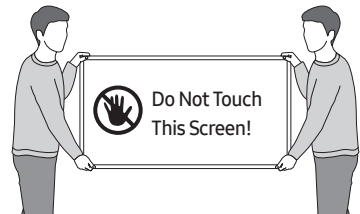

# Installing the LED TV Stand

## Assembling the Stand and Components

When installing the stand, use the provided components and parts.

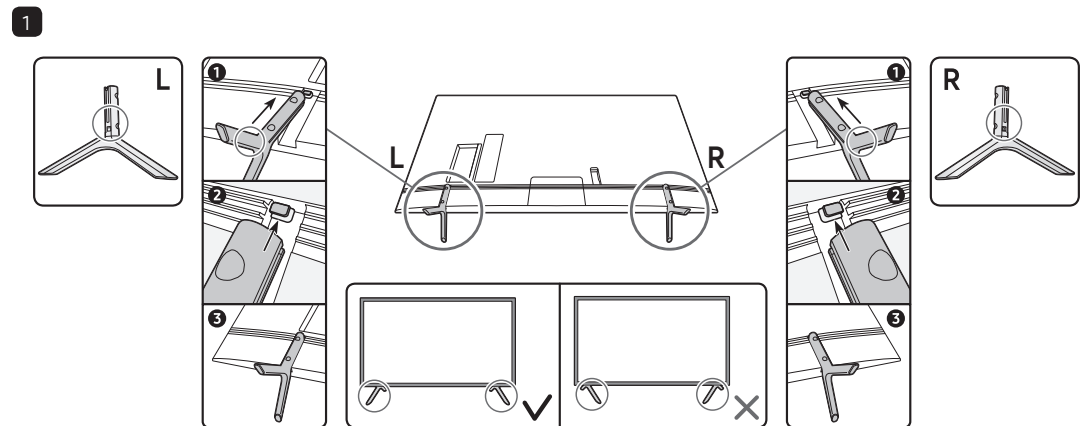

- Place a soft cloth over the table to protect the TV, and then place the TV so that its screen faces down toward the table surface.
- Insert the Stands into the slot on the bottom of the TV.
- Slide and assemble it to the end line in the direction of arrow.



2

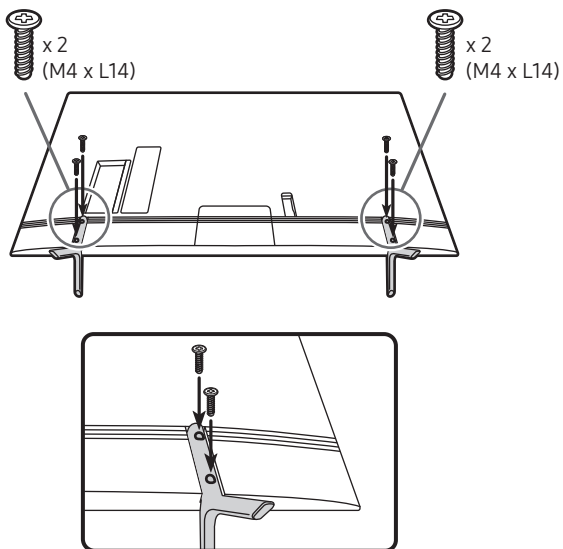

3

43"

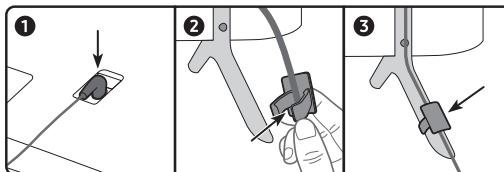
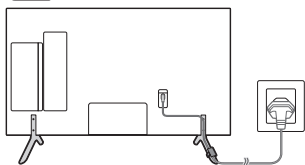

50"-75"

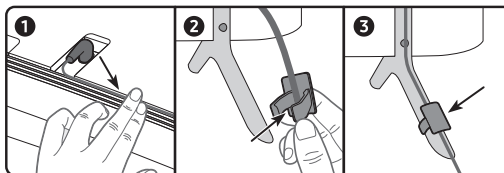
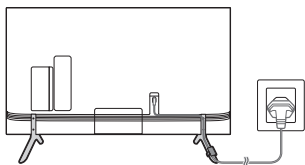

**NOTE**

- Make sure to distinguish between the front and back of each component when assembling them.
- Make sure that at least two persons lift and move the TV.

## Installing the wall mount kit

You can mount the TV on the wall using a wall mount kit (sold separately).

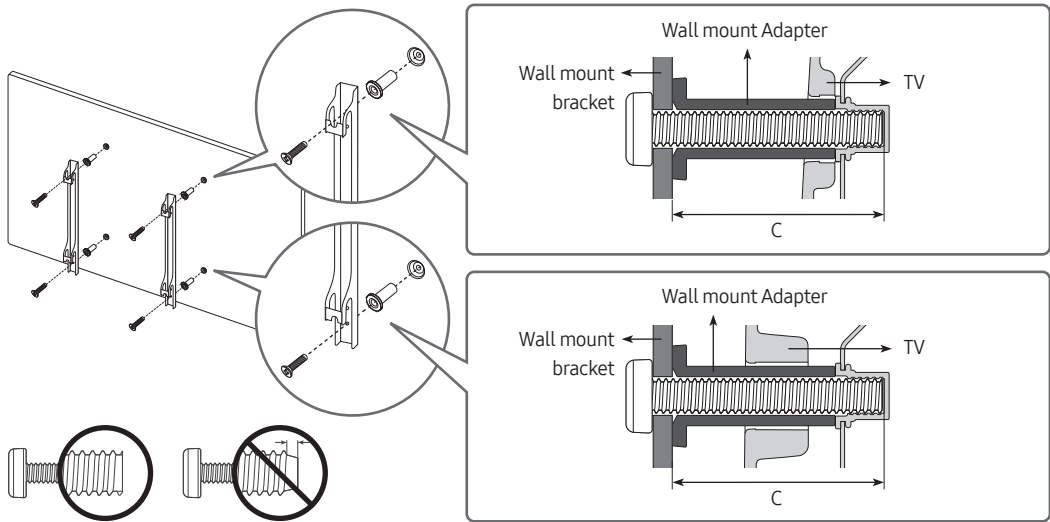

- The Product shape may differ depending on the model.

The wall mount kit (sold separately) allows you to mount the TV on a wall.

For detailed information on installing the wall mount, see the instructions provided with the wall mount. Contact a technician for assistance when installing the wall mount bracket. Samsung Electronics is not responsible for any damage to the product or injury to yourself or others if you select to install the TV on your own.

## Securing the TV to the Wall



**Caution:** Pulling, pushing, or climbing on the TV may cause the TV to fall. In particular, ensure your children do not hang on or destabilize the TV. This action may cause the TV to tip over, causing serious injuries or death. Follow all safety precautions provided in the Safety Flyer included with your TV. For added stability and safety, you can purchase and install the anti-fall device.

### To Prevent the TV from Falling

- TV Holder Kits are sold separately. To purchase a TV Holder Kit, contact a Samsung service center.
1. Insert the screws into the wall brackets and firmly fasten them to the wall. Make sure the screws are firmly fixed to the wall.
    - We strongly recommend you drive the screws into a stud.
  2. Insert the screws into the wall brackets and firmly fasten the screws to the top VESA screw holes on the back of the TV.
  3. Connect the brackets on the TV and the brackets on the wall with a strong string or cable, and then tie the string or cable tightly to the brackets.
    - Verify all connections are properly secured. Periodically check the connections for any sign of fatigue or failure. If you have any doubt about the security of your connections, contact a professional installer.
    - Install the TV close to the wall so that it does not fall.
    - Connect the string or cable so that the brackets on the wall are at the same height or lower than the brackets on the TV. Untie the string or cable before moving the TV.

## Wall Mount Kit Specifications (VESA)

Install your wall mount on a solid wall perpendicular to the floor. If you are attaching the wall mount to building materials other than plaster board, contact your nearest dealer. If installed on a ceiling or slanted wall, the TV may fall and cause severe personal injury.

- The wall mount kit is not supplied, but sold separately.
- NOTE
  - Standard dimensions for wall mount kits are shown in the table below.
  - Samsung wall mount kits contain a detailed installation manual. All parts necessary for assembly are provided.
  - Do not use screws that do not comply with the VESA standard screw specifications.
  - Do not use screws that are longer than the standard dimension or do not comply with the VESA standard screw specifications. Screws that are too long may cause damage to the inside of the TV set.
  - For wall mounts that do not comply with the VESA standard screw specifications, the length of the screws may differ depending on the wall mount specifications.
  - Do not fasten the screws too firmly. This may damage the product or cause the product to fall, leading to personal injury. Samsung is not liable for these kinds of accidents.
  - Samsung is not liable for product damage or personal injury when a non-VESA or non-specified wall mount is used or the consumer fails to follow the product installation instructions.
  - Do not mount the TV at more than a 15 degree tilt.
  - Always have two people mount the TV onto a wall.

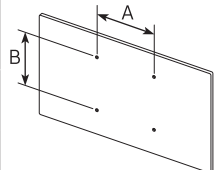
TV size in inches	VESA screw hole specs (A * B) in millimeters	C (mm)	Standard Screw	Quantity	
43-55	200 x 200	43-45	M8	4	
65-75	400 x 400				



Do not install your wall mount kit while your TV is turned on. This may result in personal injury from electric shock.

## Providing proper ventilation for your TV

When you install your TV, maintain a distance of at least 4 inches (10 cm) between the TV and other objects (walls, cabinet sides, etc.) to ensure proper ventilation. Failing to maintain proper ventilation may result in a fire or a problem with the product caused by an increase in its internal temperature.

- When you install your TV with a stand or a wall mount, we strongly recommend you use parts provided by Samsung Electronics only. Using parts provided by another manufacturer may cause difficulties with the product or result in injury caused by the product falling.

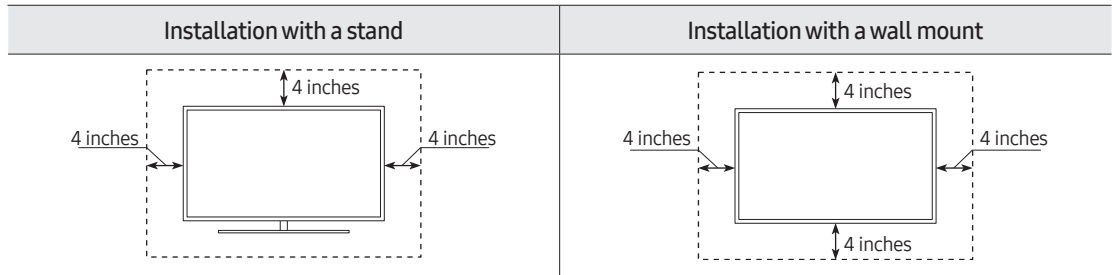

# 02 The Remote Control

## About the Buttons on the Remote Control

- The images, buttons, and functions of the remote control may differ depending on the model.
- The remote control has Braille points on the Power, Channel, Volume, and Select buttons and can be used by visually impaired persons.
- If you use the remote control that comes with your TV to control another TV, some functions may not operate normally.

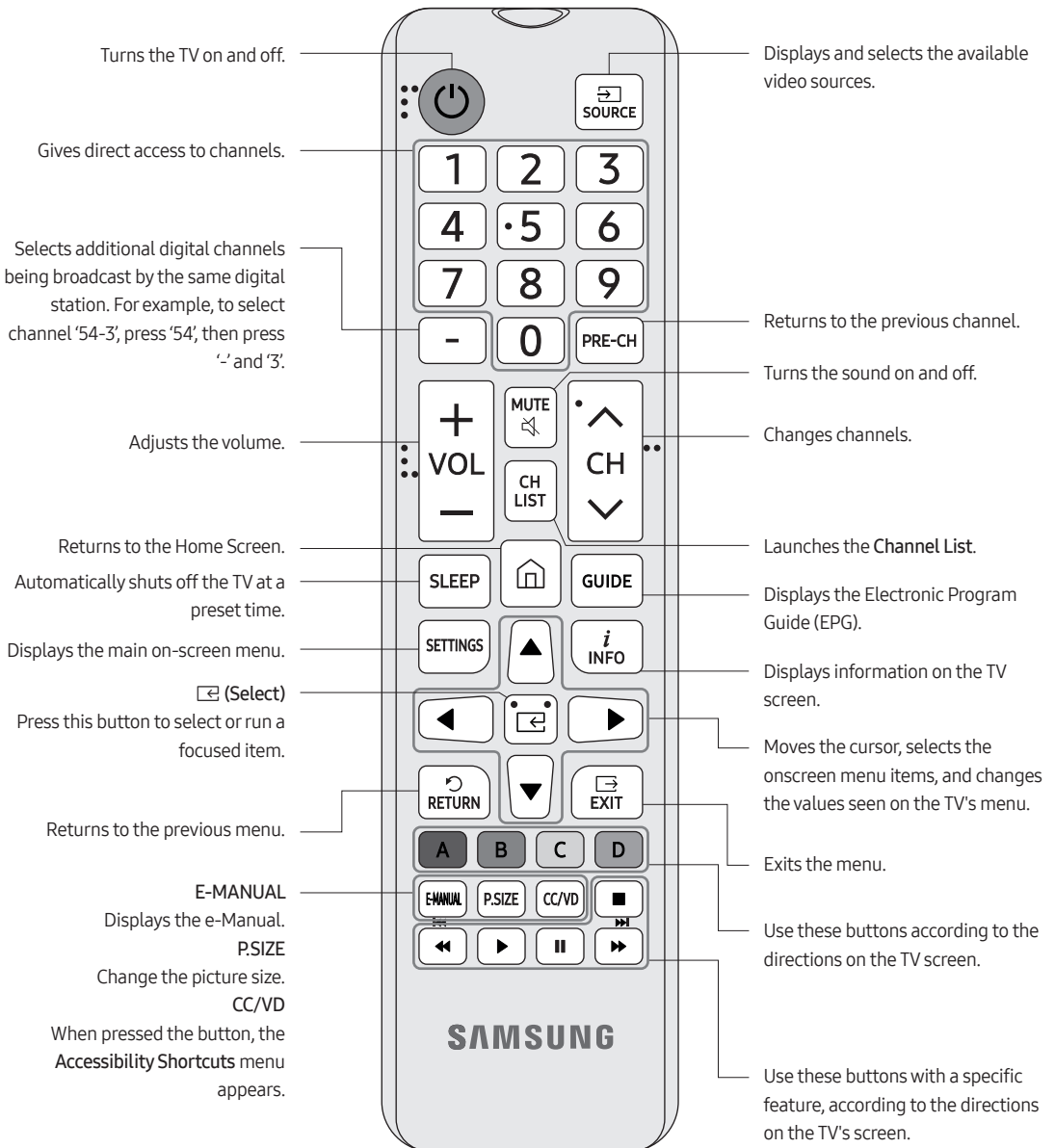

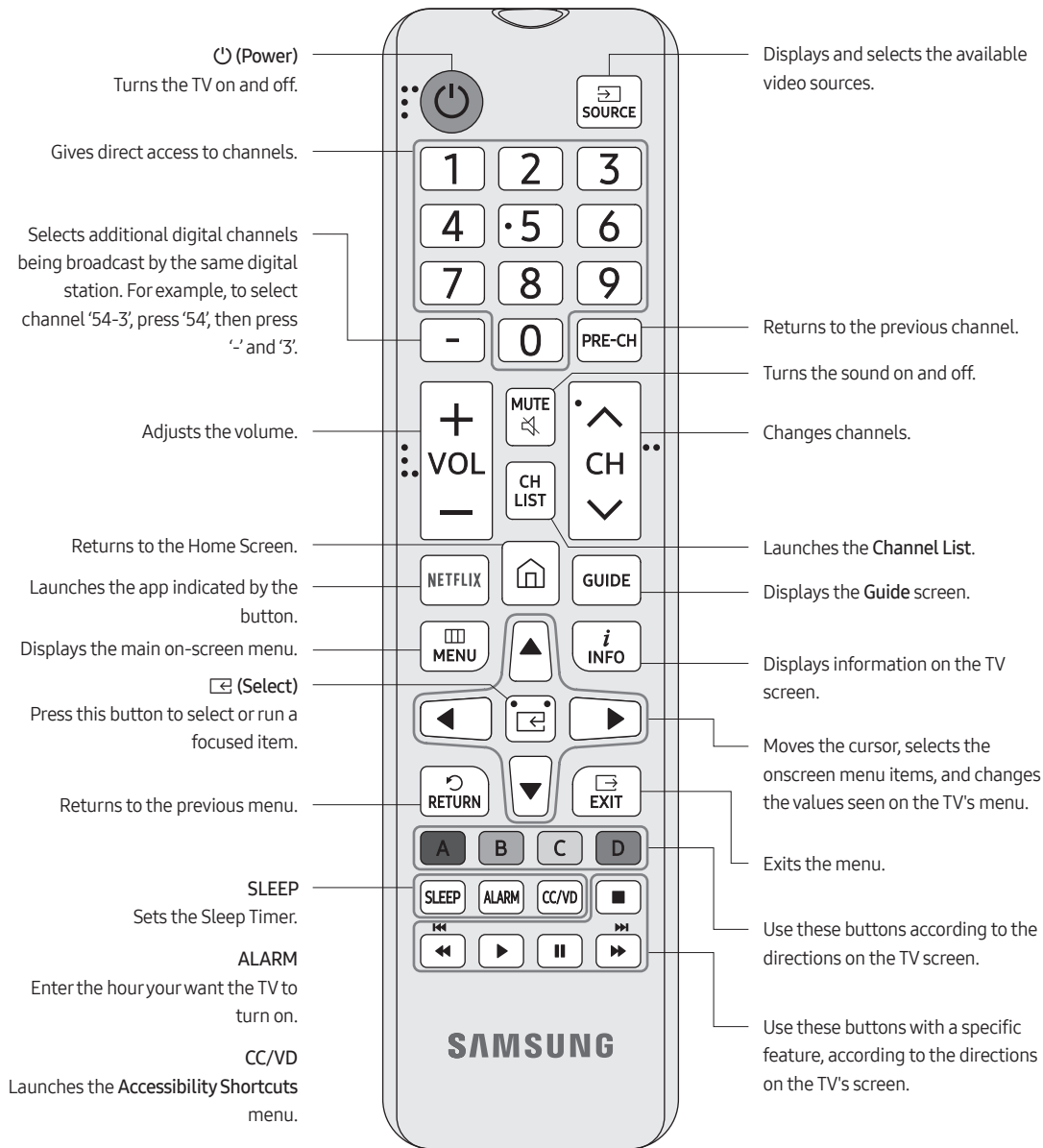

## Installing batteries into the remote control

Match the polarity of the batteries to the symbols in the battery compartment.

- Use the remote control within 23 feet (7 m) of the TV.
- Bright light may affect the performance of the remote control. Avoid using near bright fluorescent lights or neon signs.
- The color and shape of the remote may vary depending on the model.

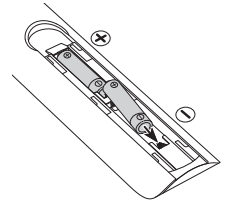

# 03 Controlling external devices with a remote control - Using the Universal Remote

You can control external devices connected to the TV using a remote control. To control external devices, register them by following instructions.

- The images on your TV may differ from the images accompanying the instructions depending on the model and geographical area.



1. Go to the **Admin menu**, and then select **Universal Remote Setting**. The **Universal Remote Setup** screen appears.
  - Admin menu > Universal Remote > Universal Remote Setting

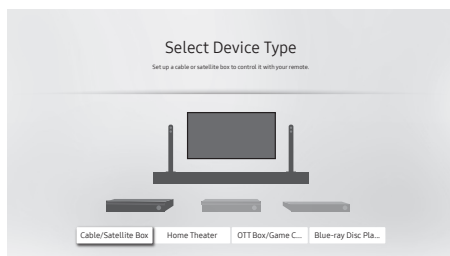

2. If the TV is connected to a set-top box, select **Cable/Satellite Box**.

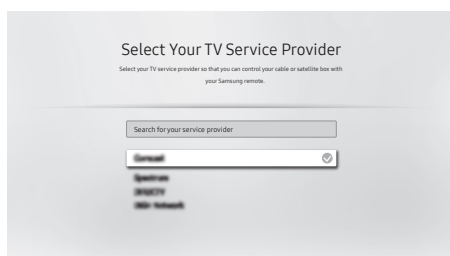

3. Select your service provider from the list in the screen. If your service provider is not listed, search manually.

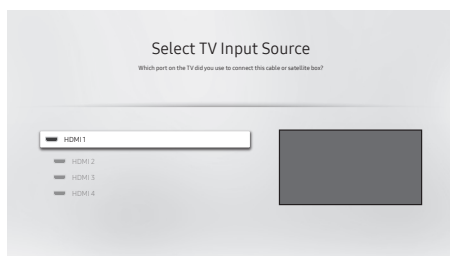

4. Select the HDMI port on the TV to which the set-top box is connected.



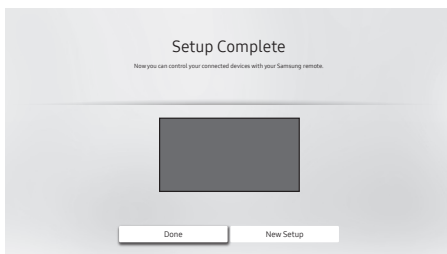
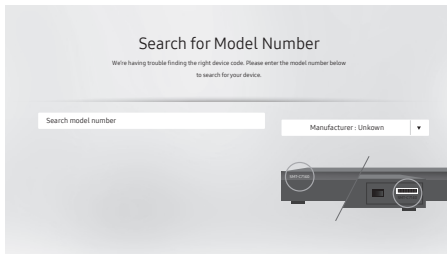
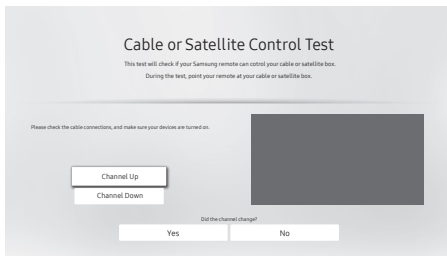

5. Press the CH button on the remote control according to the instructions on the screen in order to test whether the TV and the set-box operate correctly when you press the remote control buttons.
  - If the TV and the set-box operate correctly, select **Yes**. The setup is completed. Go to step 7.
  - If the TV and the set-box do not operate correctly, select **No**. Go to step 6.
6. Follow the instructions on the screen to search for the model number of the set-top box connected to the TV. When the model number is found, repeat step 5 for the operation test.
7. When you have completed all the settings, select **Done** in the following screen:

- This function may not be supported depending on the model or geographical area.
- You can also use the **Anynet+ (HDMI-CEC)** function to operate external Samsung devices with your TV's remote control without any additional setup.
- Specific external devices connected to the TV may not support the universal remote feature.
- Do not place any obstacles in front of an external device and TV's logo. It may cause signals from the remote control to be transmitted improperly.
- The TV memorizes both the external device and its connection port (HDMI 1, HDMI 2, etc.).

## Downloading the Universal Remote icon

1. Store the following files in the root directory of your USB device:

	File name	File type	File Size
App tile	stb_app_icon	Jpg, png	245 x 135, 2MB
Source icon	stb_source_icon	Jpg, png	135 x 135, 2MB

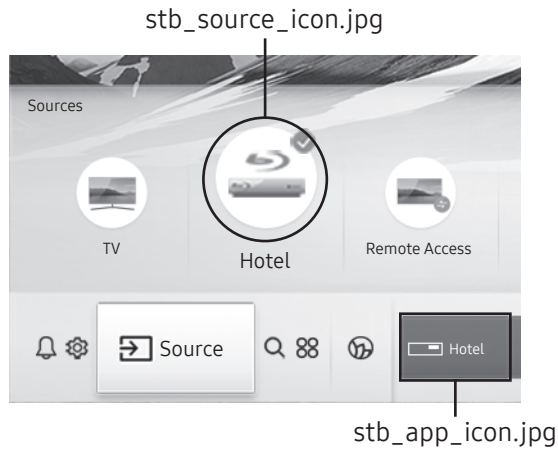

- The image on your TV may differ from the image above depending on the model and geographical area.
2. Go to the **Admin** menu, and then select **Universal Remote Icon DL**.
- **Admin menu > Universal Remote > Universal Remote Icon DL**
  - The **Universal Remote Icon DL** is only available after you have completely set up the Universal Remote.

# 04 Initial Setup

When you turn on your TV for the first time, it immediately starts the Initial Setup. Follow the instructions displayed on the screen and configure the TV's basic settings to suit your viewing environment.

If you already completed the Initial Setup, run the Initial Setup again using the following menu.

 **Admin menu > System > TV Reset**

If you select **TV Reset**, the TV resets all values to their factory defaults. When the TV turns off, press the **Power** button on the remote control to turn on the TV. The TV starts the Initial Setup.

---

## Select the region settings

- 1
  - Before select region, refer to the country list information on the right.
  - If you select the incorrect region, execute **TV Reset** again after the Initial Setup is completed.
  - If the region is changed, the TV automatically turns off and on.

---

## Selecting your TV installation type

- 2
  - **TV Basic Setup**: Select to proceed to the next step to set the basic options for using your TV.
  - **Cloning Mode**: Copy the system settings from the USB or server to the TV.
  - **Factory Menu**: End Initial Setup and go to **Admin menu** directly.

---

## Selecting your language

You can change the menu language.

---

## Set a room number.

- 4 Change the TV name to reflect a room number.

---

## Connecting to the Internet

- 5
  - Connect to an available wired or wireless network.
  - If you connect a LAN cable, the TV automatically accesses the Internet.
    - When the TV is unable to connect to the Internet automatically, check if the LAN cable is plugged in on both ends. If it is plugged in, check if the access point is turned on. If it is on, turn it off, wait 1 or 2 minutes, and then turn it on.
  - Make sure that you have the wireless access point's SSID (name) and password settings before attempting to connect. The network name (SSID) and security key are available on the wireless access point's configuration screen. See the wireless access point's user manual for more information.

---

## Agreeing to the Smart Hub service agreement, and the collection and use of personal information

- 6 To use Smart Hub, you must agree to the Smart Hub service agreement, and the collection and use of personal information. Without giving consent, you cannot use the additional features and services.

---

## Enterprise Enrollment

- 7 Sign in to your Samsung account to remotely manage the configuration of this TV from the **LYNK Cloud**.
    - This step is only supported for the RU750 series model.
-

---

	<b>Enter Your Zip code</b>
8	Enter your location to quickly find your service providers and set up your TV. – This step is not available depending on the geographical regions.

---

	<b>Select your TV source</b>
9	<ul style="list-style-type: none"> <li>• Select the type of broadcast signals the TV receives. Then, channel scanning starts.</li> <li>• After channel scanning is completed, select <b>Next</b> or press the right directional button on the remote control.</li> <li>• When the RF cable is not connected, this step is skipped.</li> </ul>

---

	<b>Setting the current time</b>
10	<ul style="list-style-type: none"> <li>• Select your time zone on the map that appears.</li> <li>• Set DST (Daylight Saving Time) to <b>No</b>, <b>Yes</b> or <b>Auto</b> to apply to the TV.</li> <li>• If the TV will be tuned to digital broadcast channels, and these channels transmit date and time information, set the <b>Clock Mode</b> to <b>Auto</b>. The TV will set the date and time automatically.</li> <li>• If the TV will not be tuned to digital broadcast channels, set the <b>Clock Mode</b> to <b>Manual</b>, and then set the date and time on the TV manually.</li> </ul>

---

11	<b>TV setup summary</b> Displays the information set on the TV.
----	--

---

	<b>Setup complete</b>
12	<ul style="list-style-type: none"> <li>• Select apps to add to Home Screen, and then try using your remote control and see if it works.</li> <li>• Select the <b>Start Watching TV</b> button to complete the Initial Setup. Then <b>Admin menu</b> appears. Press <b>Power</b> button to exit.</li> </ul>

---

- If you enter the zip code in step 8, step 10 is skipped.

## Using the TV Controller

You can turn on the TV with the **TV Controller** button at the bottom of the TV, and then use the **Control menu**. The **Control menu** appears when the **TV Controller** button is pressed while the TV is On. For more information about its usage, refer to the figure below.

- The screen may dim if the protective film on the SAMSUNG logo or the bottom of the TV is not detached. Please remove the protective film.

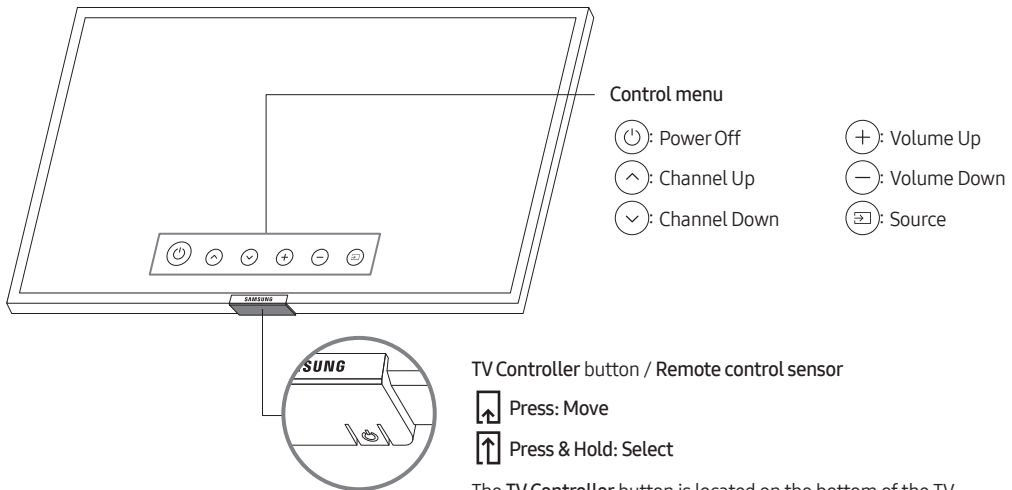

# 05 The Connection Panel

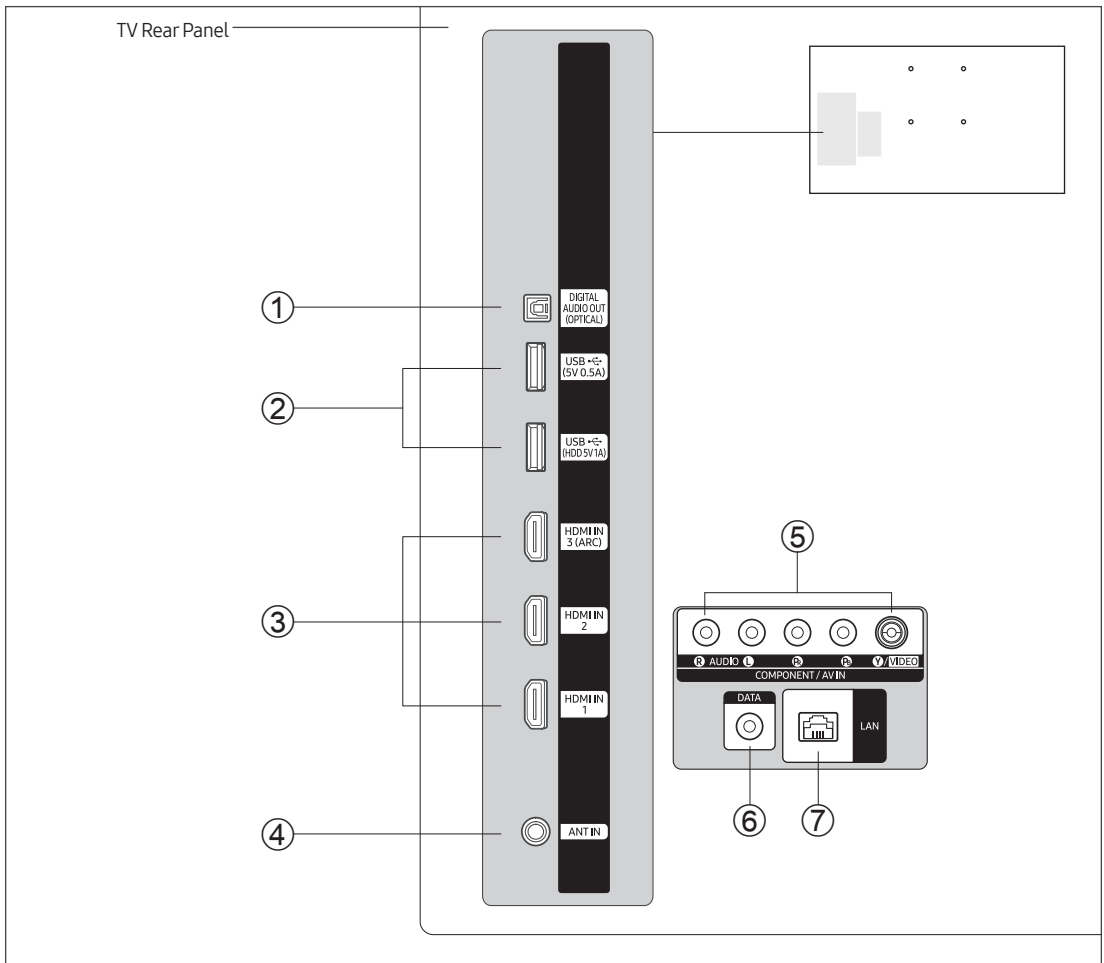

- When connecting an external device, match the color of the connection port to the cable.
- Whenever you connect an external device to your TV, make sure that power on the TV and the device is turned off.

## ① DIGITAL AUDIO OUT (OPTICAL)

Connects to a Digital Audio component.

## ② USB (5V 0.5A), USB (HDD 5V1A)

- Connector for software upgrades and Media Play, etc.
- Service connection.

## ③ HDMI IN 1, 2, 3 (ARC)

Connects to the HDMI port of a device with an HDMI output.

- No separate sound connection is needed for an HDMI to HDMI connection. HDMI connections carry both audio and video.
- It is recommended that the external device of the HDMI 1.3 or 1.4 version will be used with this TV. If you meet the compatible problem like no sound or the abnormal screen or etc with the device of the HDMI 1.2 version, contact to a Samsung service center.

④ **ANT IN**

- To view television channels correctly, the TV must receive a signal from one of the following sources:
- An outdoor antenna / A cable television system

⑤ **COMPONENT IN / AV IN**

- Use to connect to Component video / audio devices such as DVD players and AV (Composite) devices such as VCRs.
- Connect audio cables to **R-AUDIO-L** on your TV and the other ends to corresponding audio out ports on AV (Composite) devices.
- Connect component video cables (not supplied) to the component ports (**PR, PB, Y**) on your TV and the other ends to corresponding component video out ports on a DVD player. Match the colors on the ports and cables.
- If you want to connect both a set-top box and a DVD player, you should connect the set-top box to the DVD and connect the DVD to the component ports (**PR, PB, Y**) on your TV.
- The **PR, PB** and **Y** ports on your component devices (DVD) are sometimes labeled **R-Y, B-Y** and **Y** or **Cr, Cb** and **Y**.
- For AV (Composite), connect RCA audio cables (not supplied) to **R-AUDIO-L** on your TV set and the other ends to corresponding audio out ports on an external device.
- When you are connecting a AV (Composite) device to **AV IN [Y/Video]**, connect the video cable (yellow) to the **AV IN [Y/VIDEO]** port (green/yellow).

⑥ **DATA**

- Used to support data communication between the TV and the SBB or STB.
- Connects using phone-jack type plugs.
- For more information about the data cables, refer to page 27.

⑦ **LAN**

Connect to a wired LAN using CAT 7 (\*STP type) cable.

\* Shielded Twisted Pair

# 06 Connections

## Connecting to your Internet network

You can set up your TV so that it can access the SMART TV applications through your local area network (LAN) using a wired or wireless connection.

- After you have physically connected the TV to your network, you must configure the network connection to complete the process. You can configure the connection through the initial setup process or the **Admin menu** (Admin menu > Smart Service > Network Setup).

### Establishing a wireless Internet connection

Connect the TV to the Internet using a standard wireless access point or modem.

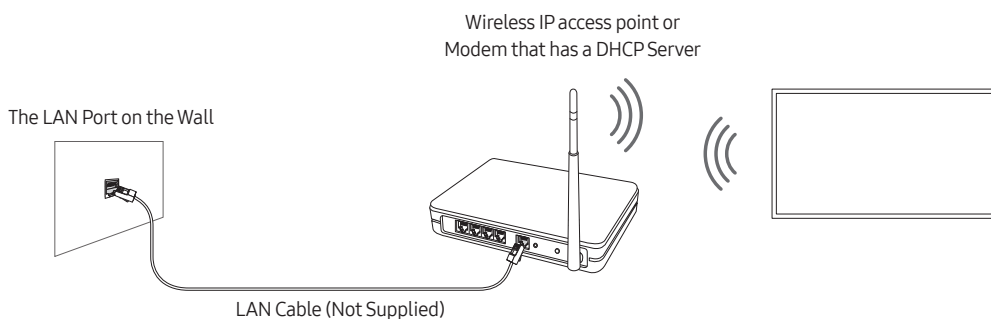

- This TV supports the IEEE 802.11 a /b /g /n /ac communication protocols. Samsung recommends using IEEE 802.11n. Otherwise, when you play video over a network connection, the video may not play smoothly.
  - Some of the IEEE 802.11 communication protocols may not be supported depending on the model or geographical area.
- To use a wireless network, the TV must be connected to a wireless access point or modem. If the wireless access point supports DHCP, the TV can use a DHCP or static IP address to connect to the wireless network.
- Select a channel that is not currently in use for the wireless access point. If the channel set for the wireless access point is currently being used by another device, the result is usually interference and/or a communications failure.
- Most wireless networks have an optional security system. To enable a wireless network's security system, you need to create a security key using characters and numbers, and then enter that key into the access point through its menu. You then must enter this security key into any other devices you want to connect to the wireless network.



## Network Security Protocols

The TV only supports the following wireless network security protocols:

- Authentication Modes: WEP, WPA2PSK, WPA2PSK
- Encryption Types: WEP, TKIP, AES

In compliance with the Wi-Fi certification specifications, Samsung TVs do not support WEP or TKIP security encryption in networks running in the 802.11n mode.

If the wireless access point supports WPS (Wi-Fi Protected Setup), you can connect the TV to your network using PBC (Push Button Configuration) or a PIN (Personal Identification Number). WPS automatically configures the SSID and WPA key settings.

Your Smart TV cannot connect to uncertified wireless access point.

## Establishing a wired Internet connection

There are three main ways to connect the TV to your network using cable, depending on your network setup. They are illustrated below:

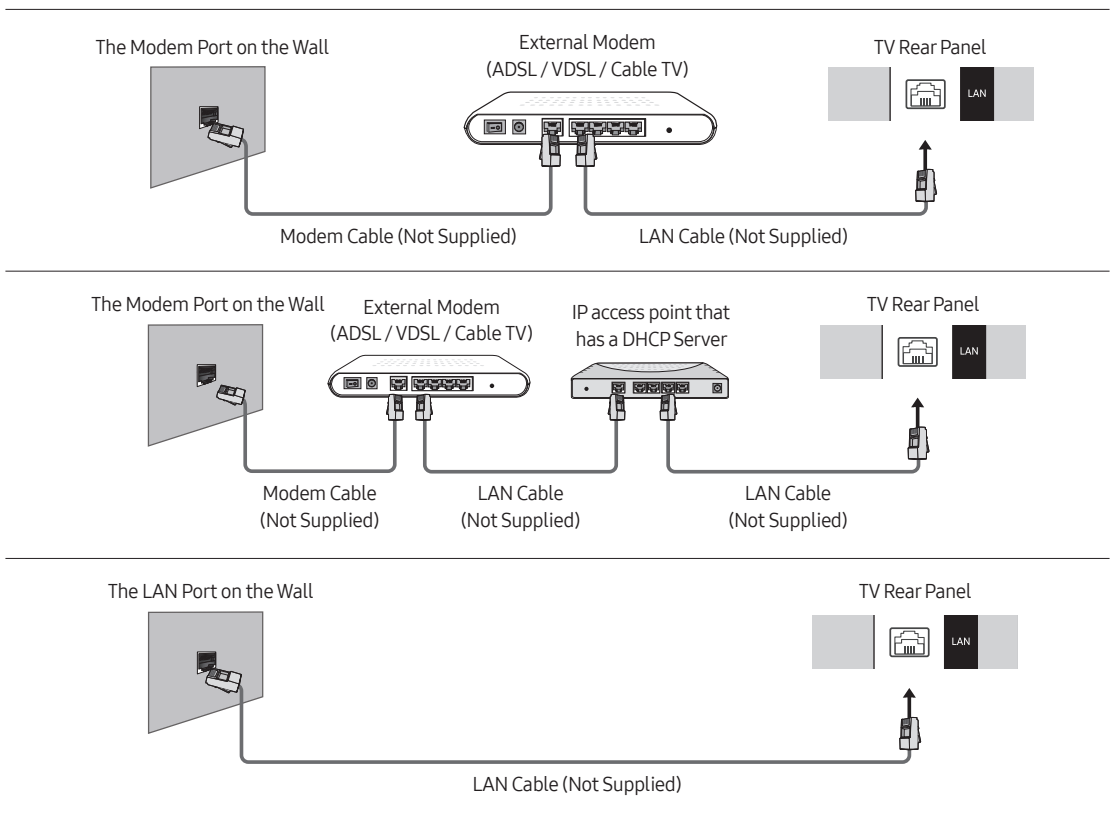

- The TV will not be able to the Internet if your network speed is less than 10 Mbps.
- Use CAT 7 (\*STP type) cable for the connection.
  - \* Shielded Twisted Pair

## Connecting the TV to a SBB or STB

---

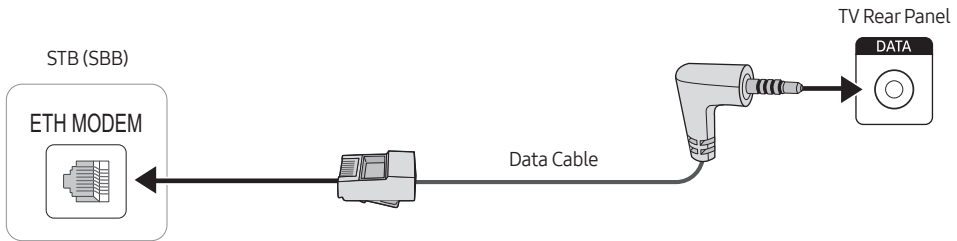

---

Connect the **DATA** port of the TV to the **ETH MODEM** port of the STB (SBB) with the Data cable.

- The **ETH MODEM** port name that you connect the Data Cable to may differ depending on the SBB or STB type.
- IR signals sent by the remote control to the TV or SBB / STB must meet the following specification to use IR pass through function.

IR signal receiver specification

- Band pass filter center frequency: 379 kHz
- Carrier Frequency, Duty 50%
- Minimum Burst Length (tburst): 12 pulses (316 us)
- Minimum Gap Time Between the burst (tburst gap): 16 pulses (422 us)
- Minimum Gap Time between the data commands (tpause): 25 ms

## List of Hospitality SI Vendors and compatible data cables supplied with the TV

- Confirm you are using the correct data cable for your SI vendor. Refer to the code label on the data cables.
- Contact your nearest dealer or your SI Vendor to buy the data cable not included in the TV.

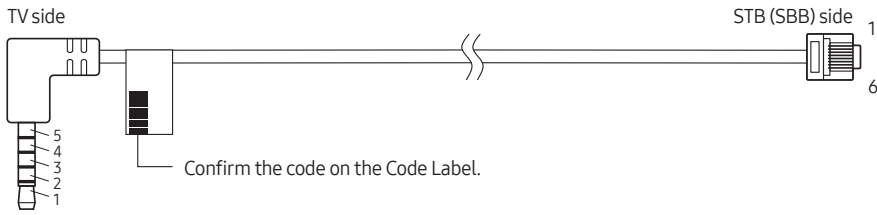

Cable code	Pin assign			SI Vendor
BN39-02462A (Color : BLACK)	<p>TV SIDE</p> <p>1: NC 2: RX 3: TX 4: IR 5: GND</p>	<p>P1 P2</p> <p>1 RED 3 2 GREEN 5 3 WHITE 6 4 BLACK 1 5 YELLOW 2</p>	<p>STB (SBB) SIDE</p> <p>1: IR 2: GND 3: NC 4: NC 5: RX 6: TX</p>	SAMSUNG and others
BN39-02461A (Color : LIGHT GRAY)	<p>TV SIDE</p> <p>1: CLK 2: RX 3: TX 4: IR 5: GND</p>	<p>P1 P2</p> <p>1 RED 6 2 GREEN 5 3 WHITE 3 4 BLACK 1 5 YELLOW 2</p>	<p>STB (SBB) SIDE</p> <p>1: IR 2: GND 3: TX 4: NC 5: RX 6: CLK</p>	MTI

- RX and TX notation is based on TV.
- Operation Specification of Data Cable(RJ12): TTL

# 07 Setting the Admin Menu

To access the **Admin menu**, press the following buttons on the remote control:

1. Press the **MUTE** button.
2. Press the **1** button.
3. Press the **1** button.
4. Press the **9** button.
5. Press the **Select** button.

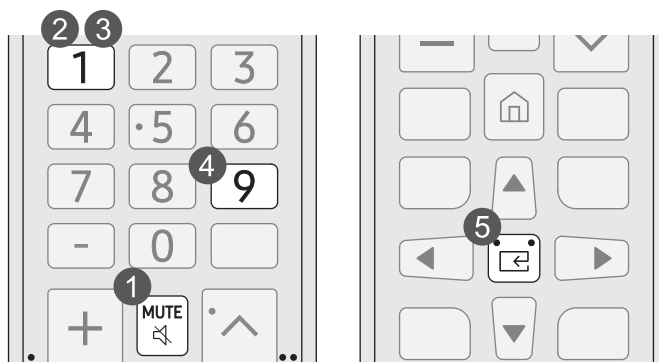

To control the TV functions in the **Admin menu**, the TV has two modes, the **Standalone** mode and the **Interactive** mode. The menu items that differ between the modes are listed below.

Menu items in the **Standalone** mode only:

- **SI Vendor:** SSCP
- \* **LYNK Cloud**, \* **LYNK HMS**, \* **Virtual Standby**, **Room Number** and its submenus.
  - \*: These functions are only supported for the RU750 series model.

Menu items in the **Interactive** mode only:

- **SI Vendor:** Samsung and other vendors.

All other items appear in both modes.

After a menu appears, follow these general directions to navigate and change values:

- Use the directional buttons on the remote control to move from menu item to menu item.
- Press the **Select** button on the remote control to select a menu item. The screen displays that menu item only.
- Press the left or right directional button to change a value. The right directional button increases numerical values. The left arrow button decreases numerical values.
- When the screen is displaying one menu item, you can press the up or down directional button to display the next or previous menu item.
- Press the **RETURN** button to exit the current menu item and go to a higher menu level.
- To exit a **Admin menu**, turn off the TV, and then turn it on again. Any changes you made are saved except changes to SI (System Integration) vendor. For changes to SI vendor, you must turn the TV off, wait until the power indicator at the bottom of the TV glows steadily. And then unplug the TV, wait for the power indicator to go off, and then plug the TV in again.

To change menus between the **Interactive** mode and the **Standalone** mode, follow the steps below:

1. Highlight the **Hospitality Mode** menu item in the top left corner of the menu.
2. Press the **Select** button on the remote control. Only the **Hospitality Mode** menu item is displayed.
3. Press the left or right directional button to change the **Hospitality Mode** item from **Standalone** to **Interactive** or from **Interactive** to **Standalone**.
4. Press the **RETURN** button on the remote control. The entire menu re-appears with your selection displayed in the **Hospitality Mode** item.
  - After you have set the values in one TV, you can clone those values to multiple TVs.
  - For more information about the USB cloning refer to page 34.

## Admin menu items

To exit from this menu, turn off (or turn off and unplug the power cable if you have changed SI vendor) the TV, and then turn on again. Any changes you made are saved.

- The menu items may not be supported depending on the models.

Admin menu Item		Description
Hospitality Mode		Select <b>Hospitality Mode</b> . <ul style="list-style-type: none"> <li>• <b>Interactive</b>: TV works with an SI STB or SBB.</li> <li>• <b>Standalone</b>: TV works alone, without an SI STB or SBB.</li> </ul>
SI Vendor		<ul style="list-style-type: none"> <li>• <b>Interactive</b>: Samsung / OCC / MTI / Nstreams / Enseio / Cardinal / Guestek / SeaChange / MDC / Innvue</li> <li>• <b>Standalone</b>: OFF / SSCP</li> </ul>
SI Config	MDC ID Settings	Assigns an individual <b>MDC ID</b> . <ul style="list-style-type: none"> <li>• This function only available when <b>MDC</b> is selected in <b>Interactive SI Vendor</b>.</li> </ul>
Power On	Power On Channel	Set the channel to display when the TV is turned on. <ul style="list-style-type: none"> <li>• <b>User Defined</b>: Lets you set the channel number manually on <b>Power On Channel Num</b>. See <b>Power On Channel Num</b> below.</li> <li>• <b>Last Saved</b>: If you select this item, when the TV is turned on, it displays the channel it was displaying when it was turned off.</li> </ul>
	Power On Channel Num	When the TV is turned on, it switches automatically to this channel.
	Power On Channel Type	Select the type of the channel will be displayed when the TV is turned on. <b>ATV</b> (analog air band), <b>DTV</b> (digital air band), <b>CATV</b> (analog cable band), <b>CDTV</b> (digital cable band), <b>IPTV</b> (IP channel, <b>IPTV</b> is set when deployed from solution.)
	Power On Volume	Set volume level when the TV is turned on. <ul style="list-style-type: none"> <li>• <b>User Defined</b>: Lets you set volume level manually.</li> <li>• <b>Last Saved</b>: When the TV is turned on, it returns to the volume that had been set when the power had been turned off.</li> </ul>
	Power On Volume Num	The TV turns on with set volume level in <b>Standalone</b> mode.
	Min Volume	The minimum volume level the user can set in <b>Standalone</b> mode.
	Max Voume	The maximum volume level the user can set in <b>Standalone</b> mode.
	Power On Source	Select the input source to be displayed when the TV is turned on.
	Power On Option	Determines the TV's state when power returns after a power failure or after you have unplugged the TV and then plugged it in again. <ul style="list-style-type: none"> <li>• <b>Last Option</b>: Returns to its last power state. If it was in standby mode, it returns to standby mode. If it was on, it turns on.</li> <li>• <b>Power ON</b>: When the power returns, the TV turns on.</li> <li>• <b>Standby</b>: When the power returns, the TV enters the standby mode.</li> </ul>

Admin menu Item		Description
Channel	Channel Setup	Gives you direct, immediate access to some of the channel menu functions on the <b>Broadcasting</b> menu such as <b>Auto Program</b> , <b>Audio Options</b> , etc.
	Channel Editor	Lets you edit the channels stored in the TV's memory. <ul style="list-style-type: none"> <li>• Change the channel numbers and names, manage genre and language groups and delete channels.</li> <li>• Apply the <b>Screen Off</b> to channels you select. The <b>Screen Off</b> blanks out the video from a channel and outputs only audio.</li> <li>• Lets you view information about each channel easily, without your having to display each channel directly.</li> </ul>
	Mixed Channel Map	Enables showing/browsing all antenna type (Air/Cable) channels at the same time. <ul style="list-style-type: none"> <li>• <b>ON</b>: When set to on, guests can access the complete channel map irrespective of the selected antenna type. The <b>Channel List/Channel Editor</b> will also populate Air as well Cable type channels.</li> <li>• <b>OFF</b>: When set to off, guest can access the channel map corresponding to the selected antenna type (Air/Cable) only. The <b>Channel List/Channel Editor</b> will only show the selected antenna type channels.</li> </ul> <p>– This function is set to <b>ON</b> automatically in <b>Interactive</b> mode.</p>
	Dynamic SI	<ul style="list-style-type: none"> <li>• <b>ON</b>: The TV will check the DTV program channel number automatically. (You can't edit DTV program channel number in <b>Channel Editor</b>.)</li> <li>• <b>OFF</b>: You can't check the DTV program channel number. (You can edit DTV program channel number in <b>Channel Editor</b>. While TV do not support auto channel number update.)</li> </ul>
	Mychannel	Enable or disable the <b>My Channel</b> function. <ul style="list-style-type: none"> <li>• This function is not available when set to <b>Hospitality Mode: Standalone</b>.</li> </ul>
Menu OSD	Picture Menu Lock	Enable or disable the <b>Picture</b> menu.
	Menu Display	<ul style="list-style-type: none"> <li>• <b>ON</b>: The main menu is displayed.</li> <li>• <b>OFF</b>: The main menu is not displayed.</li> </ul>
	Channel Menu Display	<ul style="list-style-type: none"> <li>• <b>OFF</b>: <b>Broadcasting</b> menu is disable for guest.</li> <li>• <b>ON</b>: <b>Broadcasting</b> menu is enable for guest.</li> </ul>
	Panel Button Lock	Turning the TV Controller button operations on or off. <ul style="list-style-type: none"> <li>• <b>Unlock</b>: Unlocks TV Controller button.</li> <li>• <b>Lock</b>: Locks TV Controller button.</li> <li>• <b>OnlyPower</b>: Locks TV Controller button except the power off function.</li> <li>• <b>Menu/Source</b>: Locks TV Controller button except the power off function.</li> </ul>
Clock	Local Time	Select the way to update the clock data <ul style="list-style-type: none"> <li>• <b>Auto</b>: The clock is set automatically from the DTV channel when the TV is in <b>Interactive</b> mode.</li> <li>• <b>Manual</b>: The clock is set manually by the user when the TV is in <b>Standalone</b> mode.</li> <li>• <b>Time Channel</b>: The clock is set from the selected channel.</li> </ul>
	Time Channel Type	Select the type of the channel to update the clock data. <ul style="list-style-type: none"> <li>• This function is only available <b>Local Time</b> set to <b>Time Channel</b>.</li> </ul>
	Time Channel Num	Select the number of the channel to update the clock data. <ul style="list-style-type: none"> <li>• This function is only available <b>Local Time</b> set to <b>Time Channel</b>.</li> </ul>

Admin menu Item		Description
External Source	USB Pop-up Screen	When USB is connected to the TV : <ul style="list-style-type: none"> <li>• <b>Default:</b> A popup window appears.</li> <li>• <b>Automatic:</b> This enters the USB content menu automatically.</li> <li>• <b>Disable:</b> Neither the popup window nor the menu appears.</li> </ul>
Eco Solution	Power Saving Mode	<ul style="list-style-type: none"> <li>• <b>ON:</b> Turns on the energy saving function.</li> <li>• <b>OFF:</b> Turns off the energy saving function.</li> </ul>
Cloning	Clone TV to USB	Clone the current TV options to a USB device.
	Clone USB to TV	Clone the saved TV options on a USB device to the TV.
	Setting Auto Initialize	If you set <b>Setting Auto Initialize</b> to <b>On</b> , and the TV's power is turned off and on, TV menu items are restored again to their values cloned initially.
Smart Service	Network Setup	Run the Network menu to configure your TV's network settings. You can set the following items: <ul style="list-style-type: none"> <li>• <b>Network Status:</b> View the current network and Internet status.</li> <li>• <b>Open Network Settings:</b> Connect to an available network.</li> <li>• <b>Reset Network:</b> Restore the network settings to the factory default.</li> <li>• <b>Expert Settings:</b> Configure advanced network settings.</li> </ul>
	Download by App ID	Enter the App ID. Only a registered ID can be entered.
	Apps Editable	Provide a way to enable or disable the <b>APPS</b> and <b>Notification Settings</b> menu. <ul style="list-style-type: none"> <li>• <b>ON:</b> Enable the <b>APPS</b> and <b>Notification Settings</b> menu.</li> <li>• <b>OFF:</b> Disable the <b>APPS</b> and <b>Notification Settings</b> menu.</li> </ul>
	Terms & Policy	View the entire text of the <b>Terms &amp; Policy</b> document. <ul style="list-style-type: none"> <li>• You must agree to the Smart Hub service agreement.</li> </ul>
	Smart Features	Run the <b>Smart Features</b> menu. <ul style="list-style-type: none"> <li>• <b>Autorun Smart Hub:</b> if <b>Autorun Smart Hub</b> is set to <b>On</b>, the TV automatically displays the Home Screen when you turn on the TV.</li> </ul>
	Home App Preview Editor	Edit and manage TV functions to be used from Home app.
	Quick Settings Editor	Edit the items to be displayed in <b>Quick Settings</b> and change their order.
Universal Remote	Universal Remote Setting	Run the <b>Universal Remote Setup</b> function.
	Universal Remote Icon DL	Lets you download Universal Remote icons from USB device and applying downloaded icons to the connected Universal Remote source.

Admin menu Item	Description	
Security	Factory Lock	Disable entry to <b>Admin menu</b> . <ul style="list-style-type: none"> <li>• <b>ON</b>: The password is needed before entering <b>Admin menu</b>.</li> <li>• <b>OFF</b>: Disable this function.</li> </ul>
	Password Popup	Enable or disable password input popup window. If this option is set to off, the TV will not display the password input popup window when entering the <b>Admin menu</b> . If set to <b>ON</b> , the password input popup window appears.
	Password Input	If this function is enabled, the password input popup window appears which asks for an 8-character security password. The admin must enter a password before applying or updating security preferences. After the correct password is entered, options such as <b>Password Setting</b> , <b>Password Reset</b> and <b>Security Mode</b> are available.
	Password Setting	User can change the password.
	Password Reset	Password is reset to "00000000."
	Security Mode	Provides password protected administrative functionality to enable or disable features of hospitality TV, such as <b>USB</b> , <b>HDMI</b> . To use this option, <b>Security Mode</b> set to <b>ON</b> . After <b>Security Mode</b> set to <b>ON</b> , options such as <b>USB</b> , <b>HDMI</b> are automatically enabled. <b>Clone USB to TV</b> and <b>TV Reset</b> will be disabled in the <b>Admin menu</b> .
	USB	Enable or disable USB access. If this function is set to <b>Disable</b> , access to USB media is blocked.
	HDMI	Enable or disable HDMI access. If this function is set to <b>Disable</b> , Anynet+, HDMI source, HDMI type external channels will not be accessible to the user.
DRM	DRM Mode	Configures DRM support. <ul style="list-style-type: none"> <li>• <b>OFF</b>: Turns off DRM support.</li> <li>• <b>LYNK DRM</b>: Select to turn on LYNK CAS support only.</li> </ul>
System	Self Diagnosis for HTV	<ul style="list-style-type: none"> <li>• <b>STB SI Vendor Setting</b> <ul style="list-style-type: none"> <li>– Lets you check the communication with the SI STB or SBB. If you have any problems with the communications with the SI STB or SBB, use this diagnosis function. If your broadcasting system does not have a problem, contact a Samsung service center. If <b>STB SI Vendor Setting</b> appears to have failed and communication with the SI STB or SBB has failed, first check your SI STB or SBB. If your SI STB or SBB does not have a problem, contact to a Samsung service center.</li> </ul> </li> </ul>
	Self Diagnosis for TV	Run the <b>Self Diagnosis</b> menu. <ul style="list-style-type: none"> <li>• <b>Start Picture Test</b>: Use this test when you experience a problem with your TV's picture.</li> <li>• <b>Start Sound Test</b>: Use this test when you experience a problem with your TV's sound.</li> <li>• <b>Signal Information</b>: Show digital broadcasting signal information.</li> <li>• <b>Start Smart Hub Connection Test</b>: If the TV has trouble with network connection or TV services, check the Smart Hub connection status.</li> <li>• <b>Reset Smart Hub</b>: Reset the Smart Hub and Samsung account settings stored on your TV.</li> <li>• <b>Reset</b>: Restore all TV settings, excluding network settings, to the factory defaults.</li> </ul>



Admin menu Item		Description
System	System Manager	Gives you direct, immediate access to <b>System Manager</b> functions such as <b>Time</b> , <b>Language</b> , <b>Change PIN</b> . <b>System Manager</b> allow you to adjust your TV's system and customise settings for your viewing environment.
	OTN Update	Lets you upgrade the TV Software over the network when a valid upgrade file is present on server.
	SW Update	Lets you upgrade the TV Software with a USB device.
	About This TV	Display the web site of related Samsung service center, and product and software information.
	Standby LED	When the TV is in standby mode, you can configure the settings of the power indicator. <ul style="list-style-type: none"> <li>• <b>ON</b>: The LED is on.</li> <li>• <b>OFF</b>: The LED is off.</li> </ul>
	TV Reset	Returns all settings on the TV to their factory defaults.
* LYNK Cloud	Enrollment	Lets you enroll the TV with LYNK Cloud Solution.
	Enrollment Status	Check the status of the TV enrollment in the LYNK Cloud service.
* LYNK HMS	HMS Mode	You can turn on or off the <b>HMS Mode</b> . When set to <b>ON</b> , the TV can operate with the LYNK HMS server through the IP network.
	Server URL Setting	You can enter the LYNK HMS server's address. (Example: http://192.168.1.2:8080)
	Gateway Role	When there is one TV per room, set to <b>Master</b> . When there are more than one TVs per room, set the main TV to <b>Master</b> and the others to <b>Slave</b> .
** Virtual Standby	Virtual Standby Mode	When the AC power cord is plugged in and the power is off, this option maintains the TV's important features even after the screen is off. <ul style="list-style-type: none"> <li>• Electricity consumption may vary depending on the environment.</li> </ul>
	Reboot Time	After the TV power is off (in <b>Virtual Standby Mode</b> ) if there is no input from the user within the set <b>Reboot Time</b> , the TV will reboot and enter <b>Virtual Standby Mode</b> again.
Room Number		You can set the room number of the TV's location. When <b>Device Name</b> menu is launched, enter the room number.

- \*: These functions are only supported for the RU750 series model.
- \*\*: This function is available when **Enrollment Status** in **LYNK Cloud** is set to **ON** or **HMS Mode** in **LYNK HMS** is set to **ON**. This function is only supported for the RU750 series model.
- Refer to the manual of each solution for details about functions and settings of the solutions such as LYNK Cloud, LYNK HMS.

# USB Cloning

## Admin menu > Cloning

The USB cloning function lets you download user-configured settings (**Picture, Sound, Broadcasting, Admin menu** and so on) from one TV to a USB device, and then upload these settings from the USB device to other TV sets. This lets you create a standard file of settings and distribute that standard file to all the TVs in your facility.

- After cloning, certain features are applied when the TV is turned on again.

## Cloning TV to USB: Copies stored menu settings from a TV to a USB device

### Admin menu > Cloning > Clone TV to USB

1. Insert a USB device into the USB port on the rear of the TV.
2. Go to the **Admin menu**.
3. Press the up or down directional button to select **Clone TV to USB**, and press the **Select** button on the remote control.
  - The clone folder will be labeled T-MSMAKUC / T-MSLAKUC.
  - The cloned values include the values on the guest side menu (**Picture, Sound, Broadcasting** and so on) and the **Admin menu**.

## Cloning USB to TV: Copies menu settings and channel data in a USB device to a TV

To clone data to the TV using the **Admin menu**, follow these steps:

1. Turn the TV off.
  2. Insert the USB device into the USB port on the rear of the TV.
  3. Turn the TV on.
  4. Go to the **Admin menu**.
  5. Press the up or down directional button to select **Clone USB to TV**, and press the **Select** button on the remote control.
  6. The message **Clone settings from USB to TV** is displayed. Press the **Select** button on the remote control.
    - If there is no file to copy on the USB device or the message that there is no file appears, check the folder on your USB device.
    - The folder name should be T-MSMAKUC / T-MSLAKUC.
    - Tables that list the settings that are cloned in the **Admin menu** begin on the next page.
-  Turn the TV off, insert the USB device, turn the TV on, and then press the **Select** button on the remote control for 5 seconds.

## Pre-condition for cloning (check point)

- Cloning should be done between same model (same version).
- Before cloning, all displays should be updated at the latest version (same version).

## Settings Cloned in the Admin menu

- The menu items may not be supported depending on the models.

Menu Item		Sub Item	Cloned or not
Hospitality Mode		Standalone / Interactive	Yes
SI Vendor		Interactive mode : Samsung / OCC / MTI / Nstreams / Enseio / Cardinal / Guestek / SeaChange / MDC / Innvue Standalone mode : OFF / SSCP	Yes
SI Config	MDC ID Settings	00-99	Yes
Power On	Power On Channel	User Defined / Last Saved	Yes
	Power On Channel Num	***	Yes
	Power On Channel Type	ATV / DTV / CATV / CDTV / IPTV	Yes
	Power On Volume	User Defined / Last Saved	Yes
	Power On Volume Num	0~100	Yes
	Min Volume	0~100	Yes
	Max Volume	0~100	Yes
	Power On Source	TV / HDMI1 / HDMI2 / HDMI3 / Last Saved	Yes
Power On Option		Power On / Standby / Last Option	Yes
Channel	Channel Setup	—	Yes
	Channel Editor	—	Yes
	Mixed Channel Map	ON / OFF	Yes
	Dynamic SI	ON / OFF	Yes
	MyChannel	ON / OFF	Yes
Menu OSD	Picture Menu Lock	ON / OFF	Yes
	Menu Display	ON / OFF	Yes
	Channel Menu Display	ON / OFF	Yes
	Panel Button Lock	Unlock / Lock / OnlyPower / Menu/Source	Yes
Clock	Local Time	Standalone: Manual / Time Channel Interactive: Manual / Auto / Time Channel	Yes
	Time Channel Type	DTV / CDTV	Yes
	Time Channel Num	***	
External Source	USB Pop-up Screen	Default / Automatic / Disable	Yes
Eco Solution	Power Saving Mode	ON / OFF	Yes
Cloning	Clone TV to USB	—	No
	Clone USB to TV	—	No
	Setting Auto Initialize	ON / OFF	Yes

Menu Item		Sub Item	Cloned or not
Smart Service	Network Setup	—	No
	Download by App ID	—	Yes
	Apps Editable	ON / OFF	Yes
	Terms & Policy	—	Yes
	Smart Features	Autorun Smart Hub: ON / OFF	Yes
	Home App Preview Editor	—	Yes
	Quick Settings Editor	—	Yes
Universal Remote	Universal Remote Setting	—	No
	Universal Remote Icon DL	—	Yes
Security	FactoryLock	ON / OFF	Yes
	Password Popup	ON / OFF	Yes
	Password Input	—	No
	Password Setting	—	Yes
	Password Reset	—	No
	Security Mode	ON / OFF	Yes
	USB	Enable / Disable	Yes
	HDMI	Enable / Disable	Yes
DRM	DRM Mode	OFF / LYNK DRM	Yes
System	Self Diagnosis for HTV	STB SI Vendor Setting Si Name Success / Failure	No
	Self Diagnosis for TV	—	No
	System Manger	—	No
	OTN Update	ON / OFF	Yes
	SW Update	—	No
	About This TV	—	No
	Standby LED	ON / OFF	Yes
	TV Reset	—	No
* LYNK Cloud	Enrollment	—	No
	Enrollment Status	Connected to the lynk cloud: Active / Not Active Not connected to the lynk cloud: Failure	No
* LYNK HMS	HMS Mode	ON / OFF	Yes
	Server URL Setting	—	Yes
	Gateway Role	Master / Slave	Yes
* Virtual Standby	Virtual Standby Mode	ON / OFF	Yes
	Reboot Time	OFF / 5 / 15 / 30 / 60	
Room Number		—	No

- \*: These functions are only supported for the RU750 series model.

# Setting Auto Initialize

## Admin menu > Cloning > Setting Auto Initialize

When you clone settings from one TV to another, you clone both the guest side menu and hotel side menu settings: **Picture, Sound, Broadcasting, Admin menu** and so on. This lets you set nearly all of the menu values on your hospitality TVs to the same, standard settings. If you allow guests access to the guest side menus, for example the **Picture** menu, they can change the settings in those menus so they are no longer standard. If you set the **Setting Auto Initialize** function to on, the TV automatically restores (initializes) any guest side menu values to the cloned, standard values when the TV is turned off and then turned on again. Note that **Setting Auto Initialize** works on cloned guest side menu values only. Settings which have not been cloned are ignored.

The table below lists the settings that are restored to their cloned values when you set the **Setting Auto Initialize** function to on.

- The menu items may not be supported depending on the models.

Menu Item				
Picture	Picture Mode			
	Picture Size Settings	Picture Size		
		Fit to Screen		
	Expert Settings	Backlight		
		Brightness		
		Contrast		
		Sharpness		
		Color		
		Tint (G/R)		
		Apply Picture Settings		
		Digital Clean View		
		Auto Motion Plus Settings	Auto Motion Plus	
			Judder Reduction	
			LED Clear Motion	
	Contrast Enhancer			
	Film Mode			
	Color Tone			

Menu Item				
Picture	Expert Settings	White Balance	2 Point	R-Gain
				G-Gain
				B-Gain
				R-Offset
				G-Offset
				B-Offset
			20 Point Settings	20 Point
				Interval
			Red	
			Green	
			Blue	
			Gamma	
			HLG	
			ST.2084	
	BT.1886			
	RGB Only Mode			
	Color Space Settings	Color Space		
		Color		
		Red		
		Green		
		Blue		
Sound	Sound Output			
	Sound Mode			
	Expert Settings	Balance		
		Equalizer		
		Digital Output Audio Format		
		Digital Output Audio Delay		
		Auto Volume		
Sound Feedback				
Broadcasting	Audio Options	Preferred Language		

Menu Item					
General	System Manager	Time	Clock	Clock Mode	
				Time Zone	
				DST	
		Language			
	External Device Manager	Anynet+ (HDMI-CEC)			
		Game Mode			
		Input Signal Plus			
		HDMI Black Level			
		Input Device Manager	Keyboard Settings	Keyboard Language	
				Keyboard Type	
	Eco Solution	Power Saving Mode			
		Motion Lighting			
		Auto Power Off			
	Accessibility	High Contrast			
		Grayscale			
		Color Inversion			
		Enlarge			

## Updating the TV's Software

DO NOT turn off the TV's power until the update is complete. The TV will turn off and on automatically after completing the software update. Video and audio settings will be reset to their defaults after a software update. We recommend you clone the TV's settings so that you can easily reset them after the upgrade.

- For more information about the USB cloning function, refer to page 34.

### Updating through a USB device

To update the TV's software, follow these steps:

1. Insert a USB device containing the software update file into the USB port of the TV.
  2. Run **SW Update**.
    - **Admin menu > System > SW Update**
  3. The TV displays a pop-up message that checks for the updated version.
  4. Move the focus to **OK**, and then press the **Select** button on the remote control.
- Please be careful to not disconnect the power or remove the USB device while upgrades are being applied. The TV will turn off and turn on automatically after completing the SW upgrade. Please check the SW version after the upgrades are complete.



# 08 Editing Channels

## Using Channel Editor

 Admin menu > Channel > Channel Editor

Using **Channel Editor** you can edit the channels stored in the TV's memory.

- Change the channel numbers and names, edit the channel language and channel genre and delete channels.
- If you set the **Screen Off** function to **On** for the selected channels, a screen off message is displayed, and pictures are turned off by the **Screen Off** function and only audio is output from those channels.
- **Channel Editor** also lets you view information about each channel easily, without your having to display each channel directly.

### General Steps for Using the Channel Editor in Standalone Mode



- The image on your TV may differ from the image above depending on the model and geographical area.
1. Run **Channel Setup** (**Channel > Channel Setup**) in the **Admin menu**.
  2. Enter **Channel Editor** (**Channel > Channel Editor**) in the **Admin menu**.
  3. On a piece of paper, compile a list of channels you want to have, arranged in the order you want.
  4. Based on the list created in Step 3, rearrange the channels and edit the channel names.
  5. Press the **EXIT** or **RETURN** button to exit.

## Editing the Channel Number

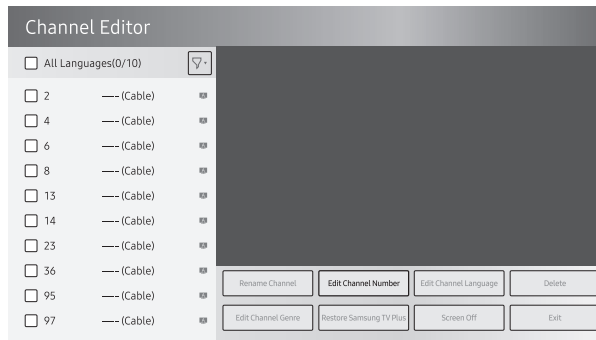

Change the channel number of a channel you select. To change a channel number, follow these steps:

1. Select a channel on the **Channel Edit** screen.
2. Use the directional buttons on the remote control, move the focus to **Edit Channel Number**, and press the **Select** button.
3. Use the up or down directional buttons on the remote control to change the channel number.
4. Move the focus to **OK** when done, and then press the **Select** button on the remote control.
  - When you change the channel number, the channel information is updated automatically.

## Rename the Channel

Change the name of a channel you select. To change the name of a channel, follow these steps:

1. Select a channel on the **Channel Edit** screen.
2. Use the directional buttons on the remote control, move the focus to **Rename Channel**, and then press the **Select** button.
3. Use the on-screen keyboard that appears to enter the new name for the channel. Use the directional buttons on the remote control, move the focus a letter or number, and then press the **Select** button. Repeat for each letter or number you want to enter.
4. When finished, move the focus to **Done**, and then press the **Select** button on the remote control.

## Assigning the Channel Number to the external device

The external device source of the TV are displayed in the last page of the **Channel Editor** menu as shown below.

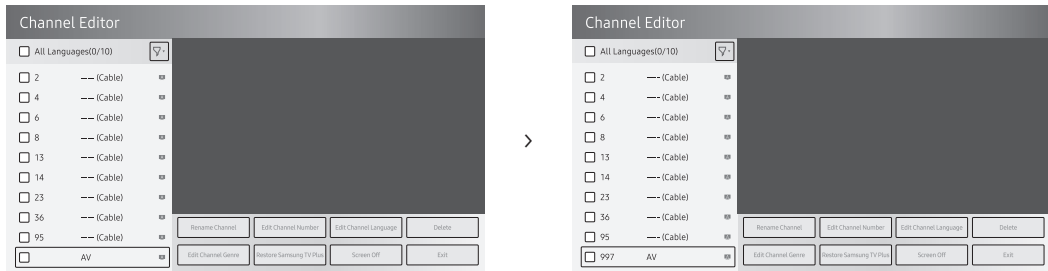

1. Select a external device source on the **Channel Edit** screen.
  2. Use the directional buttons on the remote control, move the focus to **Edit Channel Number**, and press the **Select** button.
  3. Use the up or down directional buttons on the remote control to assign the channel number.
  4. Move the focus to **OK** when done, and then press the **Select** button on the remote control.
- Once you assign a channel number to an external device, you can enter the external device without opening the TV source menu.

# 09 Specifications and Other Information

## Specifications

Model Name	HG43RU710N / HG43RU750N	HG50RU710N / HG50RU750N
Display Resolution	3840 x 2160	3840 x 2160
Screen Size Diagonal Measured Diagonally	43" Class 42.5 inches	50" Class 49.5 inches
Sound (Output)	20 W	20 W
Dimensions (W x H x D) Body	38.2 x 22.2 x 2.3 inches (970.2 x 563.2 x 58.2 mm)	44.3 x 25.6 x 2.3 inches (1124.8 x 650.2 x 59.1 mm)
With stand	38.2 x 25.1 x 8.3 inches (970.2 x 636.3 x 210.3 mm)	44.3 x 28.7 x 10.3 inches (1124.8 x 728.8 x 261.3 mm)
Weight Without Stand With Stand	21.2 lbs (9.6 kg) 21.6 lbs (9.8 kg)	30.0 lbs (13.6 kg) 30.6 lbs (13.9 kg)
Model Name	HG55RU710N / HG55RU750N	HG65RU710N / HG65RU750N
Display Resolution	3840 x 2160	3840 x 2160
Screen Size Diagonal Measured Diagonally	55" Class 54.6 inches	65" Class 64.5 inches
Sound (Output)	20 W	20 W
Dimensions (W x H x D) Body	48.8 x 28.1 x 2.3 inches (1238.6 x 714.2 x 58.7 mm)	57.4 x 33.0 x 2.3 inches (1457.5 x 837.3 x 59.1 mm)
With stand	48.8 x 31.2 x 10.3 inches (1238.6 x 792.8 x 261.3 mm)	57.4 x 36.1 x 12.3 inches (1457.5 x 917.3 x 312.8 mm)
Weight Without Stand With Stand	38.1 lbs (17.3 kg) 39.0 lbs (17.7 kg)	55.1 lbs (25.0 kg) 56.2 lbs (25.5 kg)

Model Name	HG75RU750N
Display Resolution	3840 x 2160
Screen Size Diagonal Measured Diagonally	75" Class 74.5 inches
Sound (Output)	20 W
Dimensions (W x H x D) Body  With stand	66.3 x 38.0 x 2.4 inches (1684.6 x 966.4 x 60.1 mm)  66.3 x 41.6 x 14.0 inches (1684.6 x 1056.5 x 356.1 mm)
Weight Without Stand With Stand	81.6 lbs (37.0 kg) 82.7 lbs (37.5 kg)

## Environmental Considerations

Operating Temperature	50°F to 104°F (10°C to 40°C)
Operating Humidity	10% to 80%, non-condensing
Storage Temperature	-4°F to 113°F (-20°C to 45°C)
Storage Humidity	5% to 95%, non-condensing

### Notes

- Design and specifications are subject to change without prior notice.
- For information about the power supply, and more information about power consumption, refer to the information on the label attached to the product.
  - On most models, the label is attached to the back of the TV. (On some models, the label is inside the cover terminal.)
- Your TV and its accessories may look different than the product images presented in this manual, depending on the model.
- All drawings are not necessarily to scale. Some dimensions are subject to change without prior notice. Refer to the dimensions before installing your TV. Not responsible for typographical or printed errors.

## Decreasing power consumption

When you shut the TV off, it enters Standby mode. In Standby mode, it continues to draw a small amount of power. To decrease power consumption, unplug the power cord when you don't intend to use the TV for a long time.

## Supported Resolutions for UHD Input Signals

- Resolution: 3840 x 2160p, 4096 x 2160p

### If Input Signal Plus is set to Off

Frame rate (fps)	Color Depth / Chroma Sampling	RGB 4:4:4	YCbCr 4:4:4	YCbCr 4:2:2	YCbCr 4:2:0
50 / 60	8 bit	-	-	-	0

### If Input Signal Plus is set to On

Frame rate (fps)	Color Depth / Chroma Sampling	RGB 4:4:4	YCbCr 4:4:4	YCbCr 4:2:2	YCbCr 4:2:0
50 / 60	8 bit	0	0	0	0
	10 bit	-	-	0	0
	12 bit	-	-	0	0

## Supported Resolutions for Connecting a Computer

When you use your TV as a computer monitor, you can also select one of the standard resolutions listed in the Resolution column. The TV will automatically adjust to the resolution you choose.

Mode	Resolution	Display format	Horizontal frequency (KHz)	Vertical frequency (Hz)	Clock frequency (MHz)	Polarity (horizontal / vertical)
IBM	720 x 400	70 Hz	31.469	70.087	28.322	-/+
MAC	640 x 480	67 Hz	35.000	66.667	30.240	-/-
	832 x 624	75 Hz	49.726	74.551	57.284	-/-
	1152 x 870	75 Hz	68.681	75.062	100.000	-/-
VESA DMT	640 x 480	60 Hz	31.469	59.940	25.175	- / -
	640 x 480	72 Hz	37.861	72.809	31.500	- / -
	640 x 480	75 Hz	37.500	75.000	31.500	- / -
	800 x 600	60 Hz	37.879	60.317	40.000	+ / +
	800 x 600	72 Hz	48.077	72.188	50.000	+ / +
	800 x 600	75 Hz	46.875	75.000	49.500	+ / +
	1024 x 768	60 Hz	48.363	60.004	65.000	- / -
	1024 x 768	70 Hz	56.476	70.069	75.000	- / -
	1024 x 768	75 Hz	60.023	75.029	78.750	+ / +
	1152 x 864	75 Hz	67.500	75.000	108.000	+ / +
	1280 x 720	60 Hz	45.000	60.000	74.250	+ / +
	1280 x 800	60 Hz	49.702	59.810	83.500	- / +
	1280 x 1024	60 Hz	63.981	60.020	108.000	+ / +
	1280 x 1024	75 Hz	79.976	75.025	135.000	+ / +
	1440 x 900	60 Hz	55.935	59.887	106.500	- / +
	1600 x 900	60 Hz	60.000	60.000	108.000	+ / +
1680 x 1050	60 Hz	65.290	59.954	146.250	- / +	
1920 x 1080	60 Hz	67.500	60.000	148.500	+ / +	

Mode	Resolution	Display format	Horizontal frequency (KHz)	Vertical frequency (Hz)	Clock frequency (MHz)	Polarity (horizontal / vertical)
VESA CVT	2560 x 1440	60 Hz	88.787	59.951	241.500	+ / -
	2560 x 1440	120 Hz	192.996	119.998	497.750	+ / -
CTA-861	*1920 x 1080	100 Hz	112.500	100.000	297.000	+ / +
	*1920 x 1080	120 Hz	135.000	120.003	297.000	+ / +
	3840 x 2160	30 Hz	67.500	30.000	297.000	- / -
	*3840 x 2160	60 Hz	135.000	60.000	594.000	- / -
	*3840 x 2160	100 Hz	225.000	100.000	1188.000	+ / +
	*3840 x 2160	120 Hz	270.000	120.000	1188.000	+ / +
	*4096 x 2160	100 Hz	225.000	100.000	1188.000	+ / +
	*4096 x 2160	120 Hz	270.000	120.000	1188.000	+ / +

- \*: The resolution may not be supported depending on the model.
- The interlaced mode is not supported.
- The set might operate abnormally if you select a non-standard video format.
- Separate and Composite modes are supported. SOG (Sync On Green) is not supported.
- Set **Apps Editable** to **ON** to change the input source (**Edit Name/Icon**) manually.
  - Admin menu > Smart Service > Apps Editable

# Supported Resolutions for Video Signals

Check the resolutions supported for video signals.

Mode	Resolution	Display format	Horizontal frequency (KHz)	Vertical frequency (Hz)	Clock frequency (MHz)	Polarity (horizontal / vertical)
CTA-861	720 (1440) x 576i	50 Hz	15.625	50.000	27.000	- / -
	720 (1440) x 480i	60 Hz	15.734	59.940	27.000	- / -
	720 x 576	50 Hz	31.250	50.000	27.000	- / -
	720 x 480	60 Hz	31.469	59.940	27.000	- / -
	1280 x 720	50 Hz	37.500	50.000	74.250	+ / +
	1280 x 720	60 Hz	45.000	60.000	74.250	+ / +
	1920 x 1080i	50 Hz	28.125	50.000	74.250	+ / +
	1920 x 1080i	60 Hz	33.750	60.000	74.250	+ / +
	1920 x 1080	24 Hz	27.000	24.000	74.250	+ / +
	1920 x 1080	25 Hz	28.125	25.000	74.250	+ / +
	1920 x 1080	30 Hz	33.750	30.000	74.250	+ / +
	1920 x 1080	50 Hz	56.250	50.000	148.500	+ / +
	*1920 x 1080	100 Hz	112.500	100.000	297.000	+ / +
	*1920 x 1080	120 Hz	135.000	120.003	297.000	+ / +
	1920 x 1080	60 Hz	67.500	60.000	148.500	+ / +
	3840 x 2160	24 Hz	54.000	24.000	297.000	+ / +
	3840 x 2160	25 Hz	56.250	25.000	297.000	+ / +
	3840 x 2160	30 Hz	67.500	30.000	297.000	+ / +
	*3840 x 2160	50 Hz	112.500	50.000	594.000	+ / +
	*3840 x 2160	60 Hz	135.000	60.000	594.000	+ / +
	*3840 x 2160	100 Hz	225.000	100.000	1188.000	+ / +
	*3840 x 2160	120 Hz	270.000	120.000	1188.000	+ / +
	4096 x 2160	24 Hz	54.000	24.000	297.000	+ / +
	4096 x 2160	25 Hz	56.250	25.000	297.000	+ / +
	4096 x 2160	30 Hz	67.500	30.000	297.000	+ / +
	*4096 x 2160	50 Hz	112.500	50.000	594.000	+ / +
	*4096 x 2160	60 Hz	135.000	60.000	594.000	+ / +
	*4096 x 2160	100 Hz	225.000	100.000	1188.000	+ / +
*4096 x 2160	120 Hz	270.000	120.000	1188.000	+ / +	
VESA CVT	2560 x 1440	60 Hz	88.787	59.951	241.500	+ / -
	2560 x 1440	120 Hz	192.996	119.998	497.750	+ / -

- \*: The resolution may not be supported depending on the model.
- Set **Apps Editable** to **ON** to change the input source (**Edit Name/Icon**) manually.
  - Admin menu > Smart Service > Apps Editable



# Dimensions

## Front view / Side view

The displayed image may differ from your TV, depending on the model.

- 43"

(Unit: inches)

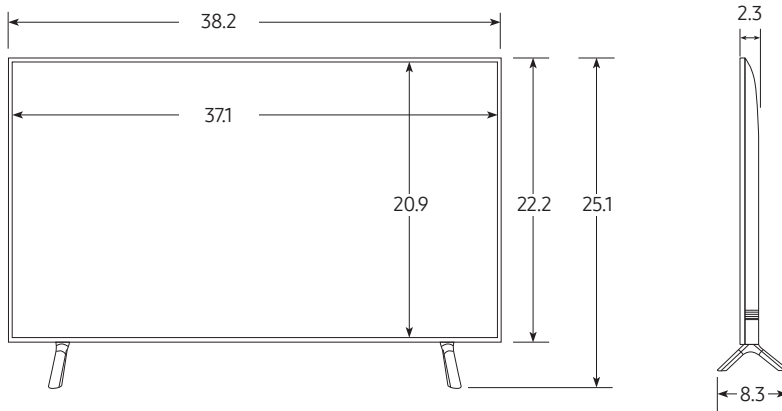

- 50"

(Unit: inches)

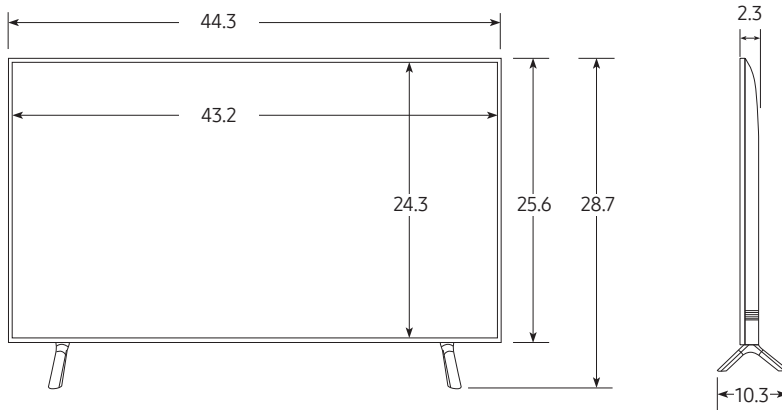

• 55"

(Unit: inches)

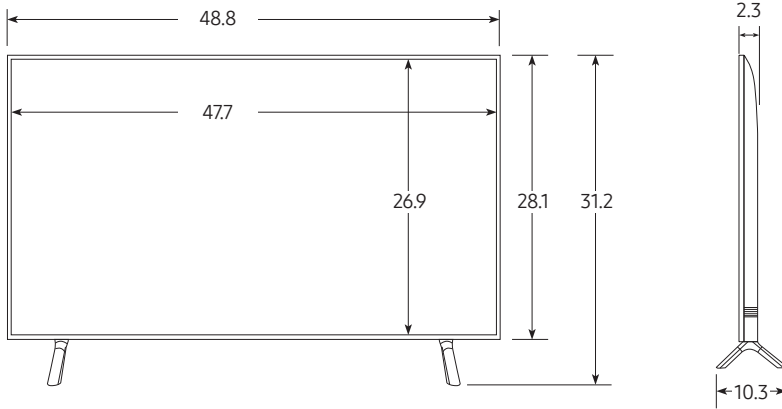

• 65"

(Unit: inches)

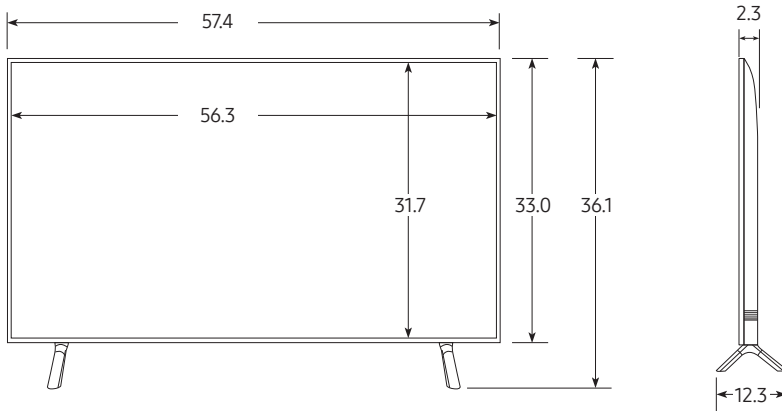

• 75"

(Unit: inches)

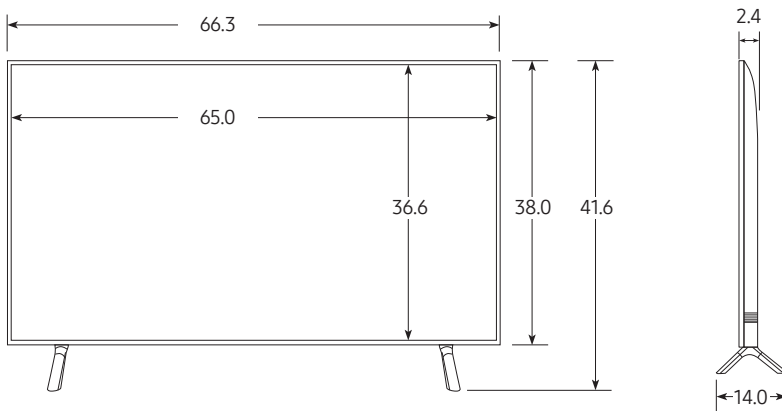

## Port panel detail / Rear view

Detailed dimensions can be checked at [Displaysolutions.samsung.com](http://Displaysolutions.samsung.com).

## Base Stand detail

The displayed image may differ from your TV, depending on the model.

- 43"

(Unit: inches)

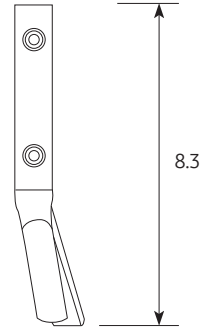
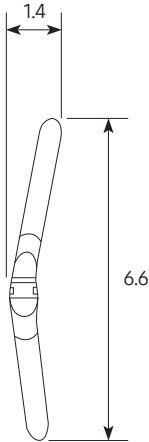

- 50"-55"

(Unit: inches)

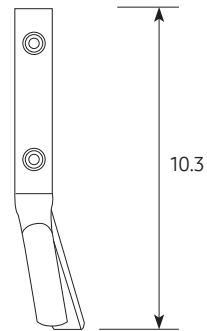
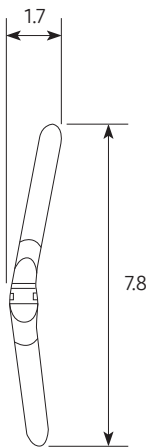

• 65"

(Unit: inches)

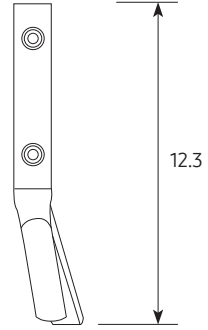
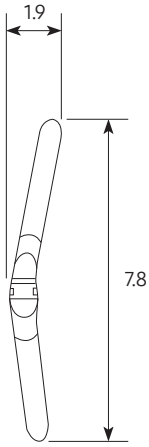

• 75"

(Unit: inches)

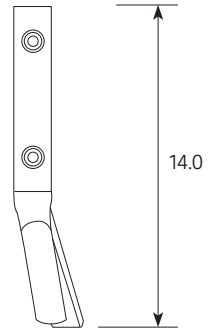
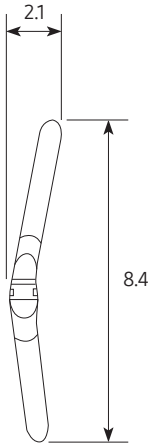

## Licenses

---



Manufactured under license from Dolby Laboratories. Dolby, Dolby Audio, Pro Logic, and the double-D symbol are trademarks of Dolby Laboratories.

---

POWERED BY

QUICKSET®

---



THIS PRODUCT IS SOLD WITH A LIMITED LICENCE AND IS AUTHORISED TO BE USED ONLY IN CONNECTION WITH HEVC CONTENT THAT MEETS EACH OF THE THREE FOLLOWING QUALIFICATIONS: (1) HEVC CONTENT ONLY FOR PERSONAL USE; (2) HEVC CONTENT THAT IS NOT OFFERED FOR SALE; AND (3) HEVC CONTENT THAT IS CREATED BY THE OWNER OF THE PRODUCT.

THIS PRODUCT MAY NOT BE USED IN CONNECTION WITH HEVC ENCODED CONTENT CREATED BY A THIRD PARTY, WHICH THE USER HAS ORDERED OR PURCHASED FROM A THIRD PARTY, UNLESS THE USER IS SEPARATELY GRANTED RIGHTS TO USE THE PRODUCT WITH SUCH CONTENT BY A LICENSED SELLER OF THE CONTENT.

YOUR USE OF THIS PRODUCT IN CONNECTION WITH HEVC ENCODED CONTENT IS DEEMED ACCEPTANCE OF THE LIMITED AUTHORITY TO USE AS NOTED ABOVE.

---



The terms HDMI and HDMI High-Definition Multimedia Interface, and the HDMI Logo are trademarks or registered trademarks of HDMI Licensing LLC in the United States and other countries.

---

### Open Source License Notice

Open Source used in this product can be found on the following webpage. (<http://opensource.samsung.com>)

Open Source License Notice is written only English.

---

# Important Warranty Information Regarding Television Format Viewing

- See the warranty card for more information on warranty terms.

Wide screen format LED Displays (16:9, the aspect ratio of the screen width to height) are primarily designed to view wide screen format full-motion video. The images displayed on them should primarily be in the wide screen 16:9 ratio format, or expanded to fill the screen if your model offers this feature and the images are constantly moving. Displaying stationary graphics and images on screen, such as the dark sidebars on nonexpanded standard format television video and programming, should be limited to no more than 5% of the total television viewing per week.

Additionally, viewing other stationary images and text such as stock market reports, video game displays, station logos, web sites or computer graphics and patterns, should be limited as described above for all televisions. Displaying stationary images that exceed the above guidelines can cause uneven aging of LED Displays that leave subtle, but permanent burned-in ghost images in the LED picture. To avoid this, vary the programming and images, and primarily display full screen moving images, not stationary patterns or dark bars. On LED models that offer picture sizing features, use these controls to view different formats as a full screen picture.

Be careful in the selection and duration of television formats used for viewing. Uneven LED aging as a result of format selection and use, as well as burned-in images, are not covered by your Samsung limited warranty.

# SAMSUNG ELECTRONICS NORTH AMERICAN LIMITED WARRANTY STATEMENT

Subject to the requirements, conditions, exclusions and limitations of the original Limited Warranty supplied with Samsung Electronics (SAMSUNG) products, and the requirements, conditions, exclusions and limitations contained herein, SAMSUNG will additionally provide Warranty Repair Service in the United States on SAMSUNG products purchased in Canada, and in Canada on SAMSUNG products purchased in the United States, for the warranty period originally specified, and to the Original Purchaser only.

The above described warranty repairs must be performed by a SAMSUNG Authorized Service Center. Along with this Statement, the Original Limited Warranty Statement and a dated Bill of Sale as Proof of Purchase must be presented to the Service Center. Transportation to and from the Service Center is the responsibility of the purchaser. Conditions covered are limited only to manufacturing defects in material or workmanship, and only those encountered in normal use of the product.

Excluded, but not limited to, are any originally specified provisions for, in-home or on-site services, minimum or maximum repair times, exchanges or replacements, accessories, options, upgrades, or consumables.

For the location of a SAMSUNG Authorized Service Center, please call toll-free:

- In the United States: 1-866-sam4biz
- In Canada: 1-800-749-0205

# SAMSUNG

## Contact SAMSUNG WORLD WIDE

If you have any questions or comments relating to Samsung products, please contact the Samsung service center.

Samsung Hospitality Hotline    1-866-sam4biz (US)  
   1-800-749-0205 (CANADA)  
   01-800-726-7864 (MEXICO)

Web site: <http://www.samsung.com/us/business>