

Dell EMC PowerEdge R6515

Technical Guide

© 2019 Dell Inc. or its subsidiaries. All rights reserved. Dell, EMC, and other trademarks are trademarks of Dell Inc. or its subsidiaries. Other trademarks may be trademarks of their respective owners.

1 Product overview	5
Introduction	5
New technologies	5
2 System features	6
Product comparison	6
3 Chassis views and features	7
Front view of the system	7
Rear view of the system	8
Inside the system	8
Quick Resource Locator fo Dell EMC PowerEdge R6515 system	9
4 Processor	10
Processor features	10
Supported processors	10
5 Memory	11
Supported memory	11
Memory speed	12
6 Storage	13
Supported drives	13
Storage controller	13
Optical drives	14
External Storage	14
7 Networking and PCIe	15
Expansion card installation guidelines	15
8 Power, thermal, and acoustics	18
Power	18
Thermal	18
Acoustics	19
9 Supported operating systems	20
10 Dell EMC OpenManage systems management	21
iDRAC9 with Lifecycle Controller	21
Agent-free management	25
Agent-based management	25
Dell EMC consoles	25
Dell EMC OpenManage systems management tools, utilities and protocols	26

Integration with third-party consoles.....	27
OpenManage connections with third-party consoles.....	28
11 Appendix A. Additional specifications.....	29
Chassis dimensions.....	29
Chassis weight.....	30
Video.....	30
USB.....	30
Environmental specifications.....	30
12 Appendix B. Standards compliance.....	33
13 Appendix C Additional resources.....	34
14 Appendix D. Dell Technologies Services	35
ProDeploy Enterprise Suite and Residency Services.....	35
ProDeploy Plus.....	36
ProDeploy.....	36
Basic Deployment.....	36
Server Configuration Services.....	36
Residency Services.....	36
Remote Consulting Services.....	36
Data Migration Service.....	36
ProSupport Enterprise Suite.....	36
ProSupport Plus.....	37
ProSupport.....	37
ProSupport One for Data Center.....	38
Support Technologies.....	38
Education Services.....	39
Dell Technologies Consulting Services.....	39
Managed Services.....	39

Product overview

Introduction

The Dell EMC PowerEdge R6515 (1U rack system) is a 1-socket, 1U server designed to run complex workloads, using highly scalable memory, I/O, and network. The system is based on the 2ND Generation AMD® EPYC™ processor, supports up to 64 Zen2 x86 cores, 16 DIMMs, PCI Express® (PCIe) 4.0 enabled expansion slots, and a choice of LOM Riser technologies.

The R6515 is a general-purpose platform capable of handling demanding workloads and applications, such as data warehouses, ecommerce, databases, and high-performance computing (HPC). Also, the server provides extraordinary storage capacity options, making it well-suited for data-intensive applications without sacrificing I/O performance.

New technologies

Table 1. PowerEdge R6515 new technologies

Technology	Detailed Description
2ND Generation AMD EPYC™ Based Server SOCs	<ul style="list-style-type: none"> • A highly scalable, 64-core System on Chip (SoC), design with support for two high-performance threads per core • 7nm process technology • Industry-leading memory bandwidth, with 8-channels of memory per "Rome" device. In a 1-socket server, support for up to 16 DIMMs of DDR4 on 8 memory channels, delivering up to 2 terabytes of total memory capacity • The processor is a complete SoC with fully integrated, high-speed I/O supporting 128 lanes of PCIe Gen3, negating the need for a separate chipset • A highly-optimized cache structure for high-performance, energy efficient compute • Dedicated security hardware
DDR4 Memory	<ul style="list-style-type: none"> • Support up to 3200 MT/s for 1 DIMM per channel • Support two DIMMs per channel up to 2933 MT/s with these processors • Support 8x DDR4 channels per socket, 2 DIMMs per channel (2DPC) • Support RDIMMs up to 64 GB and LRDIMMs up to 128 GB
iDRAC9 w/ Lifecycle Controller	<p>The embedded systems management solution for Dell servers features hardware and firmware inventory and alerting, in-depth memory alerting, faster performance, a dedicated gigabit port and many more features.</p>
Wireless Management	<p>The Quick Sync feature is an extension of NFC based low bandwidth interface. Quick Sync 2.0 offers feature parity with the previous versions of the NFC interface with improved user experience.</p> <p>Since the introduction of iDRAC in PowerEdge Servers, the server management system has been improved by adding different local and remote user interfaces (Web GUI, RACADM, WSMAN, BIOS F2 Setup, and LCD) to iDRAC. Quick Sync 1.0 (NFC) interface was added to hand held devices (mobile, tablet) through the Dell OMM Android application. Quick Sync 2.0 replaces previous generations of the NFC technology to extend the feature to a wider variety of mobile operating systems with higher data throughput.</p> <p>The 2nd Generation AMD® EPYC™ Rome processors provide several Zen 2 Rome SKUs, ranging from 16 cores to 64 cores variants to support workloads for data warehouses, e-commerce, high-performance computing, and storage for data centers.</p>

System features

Product comparison

The following table shows the comparison between the PowerEdge R6515 with the R6415:

Table 2. Product comparison

Feature	PowerEdge R6515	PowerEdge R6415
CPU	AMD® Rome SP3	AMD® Naples SP3
Memory	16x DDR4 RDIMM, LRDIMM, 3DS	16x DDR4 RDIMM, LRDIMM
Disk Drives	3.5 -inch and 2.5 -inch: <ul style="list-style-type: none"> 12G SAS 6G SATA HDD/SSD 	3.5 -inch and 2.5 -inch: <ul style="list-style-type: none"> 12G SAS 6G SATA HDD/SSD
Storage Controllers	<ul style="list-style-type: none"> Mini PERC: HBA330, H330, H730P, H740P, H840 SW RAID: S150 	<ul style="list-style-type: none"> Mini PERC: HBA330, H330, H730P, H740P, H840 SW RAID: S140
PCIe SSD	Up to 10x PCIe SSD	Up to 10x PCIe SSD
PCIe Slots	Up to 2: <ul style="list-style-type: none"> 1 x Gen3 slot (x16) 1 x Gen4 slot (x16) 	Up to 2 <ul style="list-style-type: none"> 2 x Gen3 slot (x16)
OCP 2.0	OCP Type 1: (Connector A)	OCP Type 1: (Connector A)
USB Ports	<ul style="list-style-type: none"> Front: 1 x USB 2.0 port, 1 x iDRAC USB(Micro USB) port Rear: 2 x USB 3.1_Gen1 port Internal: 1 x USB 3.0 port 	<ul style="list-style-type: none"> Front: 1 x USB 2.0 port, 1 x iDRAC USB(Micro USB) port Rear: 2 x USB 3.1_Gen1 port Internal: 1 x USB 3.0 port
Rack Height	1U	1U
Power Supplies	550W AC Platinum	<ul style="list-style-type: none"> 450W AC Gold (cabled) 550W AC Platinum
System Management	<ul style="list-style-type: none"> Lifecycle Controller 3.x OpenManage Quick Sync2.0 OpenManage Enterprise Power Manager Digital License Key iDRAC Direct (dedicated micro-USB port) Easy Restore 	<ul style="list-style-type: none"> Lifecycle Controller 3.x OpenManage Quick Sync2.0 OMPC3 Digital License Key iDRAC Direct (dedicated micro-USB port) Easy Restore vFlash
Availability	<ul style="list-style-type: none"> Hot-plug drives Hot-plug redundant power supplies BOSS IDSDM 	<ul style="list-style-type: none"> Hot-plug drives Hot-plug redundant power supplies BOSS IDSDM

Chassis views and features

Front view of the system



Figure 1. Front view of 4 x 3.5-inch drive system

- | | |
|-----------------------|-----------------------------|
| 1. Left control panel | 2. Optical drive (optional) |
| 3. VGA port | 4. Right control panel |
| 5. Information tag | 6. Drive (4) |

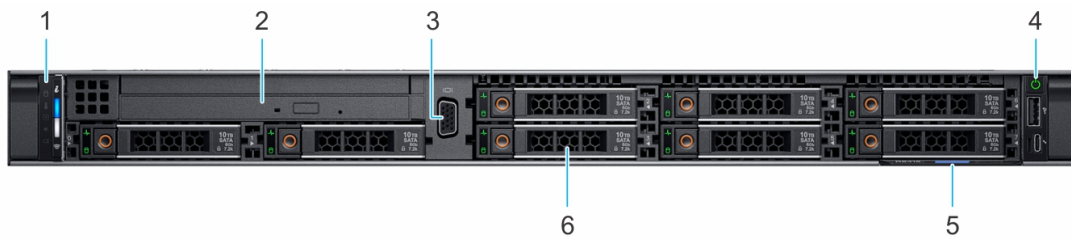

Figure 2. Front view of 8 x 2.5-inch drive system

- | | |
|-----------------------|-----------------------------|
| 1. Left control panel | 2. Optical drive (optional) |
| 3. VGA port | 4. Right control panel |
| 5. Information tag | 6. Drive (8) |

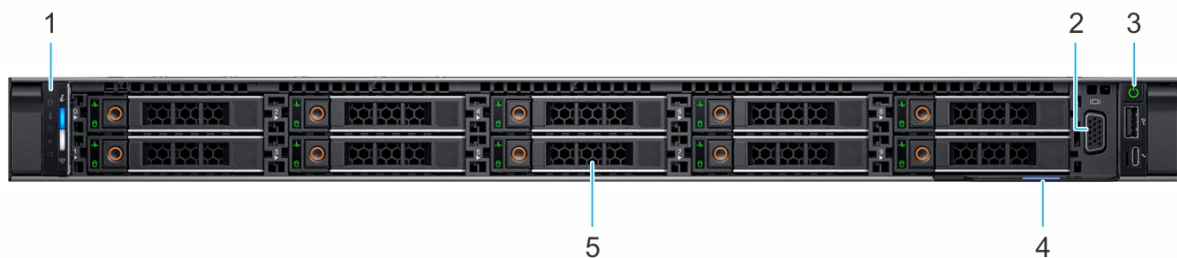

Figure 3. Front view of 10 x 2.5-inch drive system

- | | |
|------------------------|--------------------|
| 1. Left control panel | 2. VGA port |
| 3. Right control panel | 4. Information tag |
| 5. Drive (10) | |

Rear view of the system

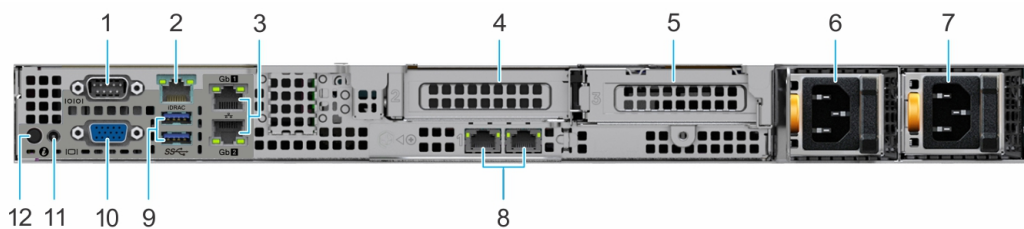

Figure 4. Rear view of the system

- 1. Serial port
- 2. iDRAC9 dedicated network port
i NOTE: Enables you to remotely access iDRAC.
- 3. NIC ports (2)
- 4. PCIe expansion card riser 1A (slot 2)
- 5. PCIe expansion card riser 2 (slot 3)
- 6. Power supply units (2)
- 7. LOM Riser Ethernet port (2) (Optional)
- 8. USB 3.0 port (2)
- 9. VGA port
- 10. System status indicator cable port
- 11. System identification button
- 12. System status indicator cable port

Inside the system

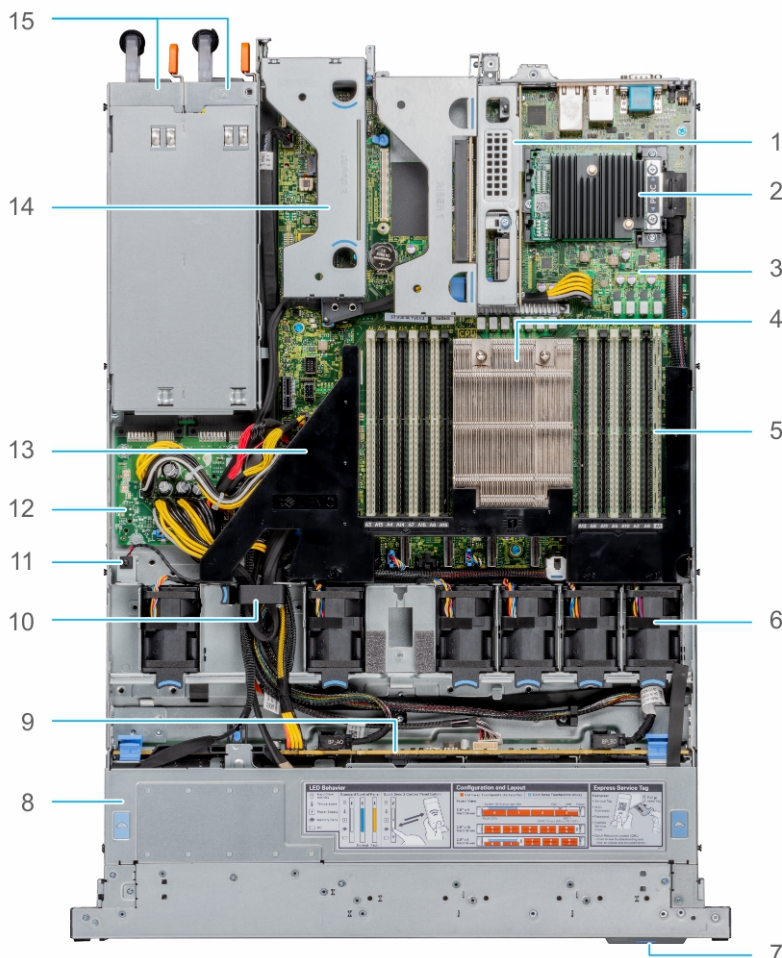

Figure 5. Inside the system

- 1. riser 1A
- 2. mini PERC card

- 3. system board
- 5. memory module slots
- 7. information tag
- 9. backplane
- 11. intrusion switch
- 13. air shroud
- 15. PSU 1 and PSU 2

- 4. processor
- 6. fan
- 8. backplane cover
- 10. cable retention latch
- 12. power interposer board
- 14. riser 2

Quick Resource Locator fo Dell EMC PowerEdge R6515 system



Figure 6. Quick Resource Locator for PowerEdge R6515 system

Processor

The AMD® Rome processor has several Zen 2 Rome SKUs ranging from 16 cores and up to 64 cores variants. Along with performance, 7nm FinFET would also prove a great process for efficiency optimizations.

Topics:

- [Processor features](#)
- [Supported processors](#)

Processor features

The key features of the 2nd Generation AMD® EPYC™, codenamed Rome, are as follows:

- A highly scalable, 64-core System on Chip (SoC) design, with support for two high-performance threads per core
- Industry-leading memory bandwidth, with 8-channels of memory per Rome device. The single socket system supports up to 16 DIMMS of DDR4, delivering up to 2TB of total memory capacity
- The processor is a complete SoC with fully integrated, high-speed I/O supporting 128 lanes of PCIe®, negating the need for a separate chip-set
- A highly-optimized cache structure for high-performance and energy efficient compute
- Dedicated security hardware

Supported processors

Table 3. Supported Processors for R6515

Processor	Frequency (GHz)	Cores	Cache (MB)	TDP (W)
7742	2.25	64	256	225
7702P	2.0	64	256	200
7542	2.9	32	128	225
7502P	2.5	32	128	180
7402P	2.8	24	128	180
7452	2.35	32	128	155
7352	2.3	24	128	155
7302P	3.0	16	128	155
7262	3.2	8	128	155

Memory

The PowerEdge R6515 system supports up to 16 DIMMS, 2 TB of memory, and speeds up to 3200MT/s

The Socket SP3 processor contains eight 64-bit (64 DATA bits plus 8 CHECK bits) DDR4 SDRAM memory controllers operating in ungangned mode. The maximum capacity is 16 DDR4 SDRAM DIMMs, two per memory controller. The memory channels are organized as 4 channels per processor side, with memory channels A,B, C and D on one side and memory channels E, F, G and H on the other side.

Support registered (RDIMMs), load reduced DIMMs (LRDIMMs), and 3-Dimensional Stack DIMMs (3-DS DIMMs) use a buffer to reduce memory loading and provide greater density, allowing for the maximum platform memory capacity. Unbuffered DIMMs (UDIMMs) are not supported.

Topics:

- [Supported memory](#)
- [Memory speed](#)

Supported memory

Routing is daisy-chain 2-RDIMM per channel, therefore back-to-front population of RDIMM is preferred. Quad-rank and octal-rank are supported for LRDIMMs.

The table below lists the memory technologies supported by the R6515 in comparison to the R6415:

Table 4. Memory technology comparison

Feature	R6515(DDR4)	R6415(DDR4)
DIMM type	RDIMM	RDIMM
	LRDIMM	LRDIMM
	3DS	N/A
Transfer speed	3200 MT/s	2667 MT/s
	2933 MT/s	2400 MT/s
	2666 MT/s	2133 MT/s
	N/A	1866 MT/s
Voltage	1.2V	1.2V

The following table shows the supported DIMMs for the PowerEdge R6515:

Table 5. Supported DIMMs

DIMM Speed (MT/s)	DIMM Type	DIMM Capacity (GB)	Ranks per DIMM	Data Width	DIMM Volts
3200	RDIMM	8	1	8	1.2
3200	RDIMM	16	2	8	1.2
3200	RDIMM	32	2	4	1.2
3200	RDIMM	64	2	4	1.2
2666	LRDIMM	128	8	4	1.2

Memory speed

The table below lists the memory configuration and performance details for the PowerEdge R6515 based on the quantity and type of DIMMs per memory channel.

Table 6. DIMM performance details

DIMM type	DIMM ranking	Capacity	DIMM rated voltage, Speed	AMD Rome	
				1DPC	2DPC
RDIMM	1R	8 GB	DDR4 (1.2V), 3200 MT/s	3200 MT/s	2933 MT/s
	2R	16 GB, 32 GB, 64 GB	DDR4 (1.2V), 3200 MT/s	3200 MT/s	2933 MT/s
LRDIMM	8R	128 GB	DDR4 (1.2V), 2666 MT/s	2666 MT/s	2666 MT/s

Storage

The PowerEdge R6515 provides various options of drive types.

The following table shows the types of drive configurations on the PowerEdge R6515:

Table 7. Hard drive configurations

R6515 Configuration details	Storage module	Rear storage module	Controllers
4x3.5 -inch, SAS** or SATA only	4 x 3.5 -inch	None	CPU Direct SATA, SWRAID SATA, Mini PERC (H330, H730P, H740P, HBA330)
8x2.5 -inch, SAS**	8 x 2.5 -inch	None	Mini PERC (H330, H730P, H740P, HBA330)
8x2.5 -inch, 8 Universal*** and 2 NVMe	10 x 2.5 -inch Passive	None	CPU direct NVMe; SWRAID NVMe, Mini PERC (H740P, HBA330)

NOTE: **SAS represents SAS/SATA capable backplane.

NOTE: ***Universal represents SAS/SATA/NVMe capable slots.

Topics:

- [Supported drives](#)
- [Storage controller](#)
- [Optical drives](#)
- [External Storage](#)

Supported drives

The PowerEdge R6515 system supports SAS, SATA, Nearline SAS drives/SSD drives.

Table 8. Supported drives - SAS and SATA or SSD

Form Factor	Interface	RPM	Sector Format	Capacities
2.5"	SAS	15K	512n	900GB
		10K	512e	2.4TB, 2.4TB FIPS SED
			512n	600GB, 1.2TB / 1.2TB FIPS SED
3.5"	SAS	7.2K	512e	8TB / 8TB FIPS SED, 12TB / 12TB FIPS SED, 16TB / 16TB FIPS SED
			512n	2TB, 4TB / 4TB FIPS SED
	SATA	7.2K	512e	8TB, 12TB, 16TB
			512n	2TB, 4TB

Storage controller

Dell EMC RAID controller options offer performance improvements, including the Mini PERC solution. Mini PERC provides a base RAID HW controller without consuming a PCIe slot by using a small form factor and high density connector to the base planar.

The following table shows the supported storage controllers for the PowerEdge R6515:

Table 9. Supported storage controllers

Performance level	Controller description
Entry	<ul style="list-style-type: none"> S150 (SATA, NVMe) SW RAID SATA
Value	<ul style="list-style-type: none"> HBA330 (Internal), 12Gbps SAS HBA (External) <ul style="list-style-type: none"> Fury IOC Memory: None x8 12 Gb SAS x8 PCIe 3.0 H330, 12Gbps SAS HBA (External) <ul style="list-style-type: none"> Fury IOC Memory: None x8 12 Gb SAS x8 PCIe 3.0
Value performance	<ul style="list-style-type: none"> H730P <ul style="list-style-type: none"> Invader ROC Memory: 2GB, NV 72-bit, 866MHz x8 12 Gb SAS x8 PCIe 3.0
Premium performance	<ul style="list-style-type: none"> H740P, H840(UI) <ul style="list-style-type: none"> Harpoon 8x8 ROC Memory: 4/8GB, NV 72-bit

Optical drives

The PowerEdge R6515 supports the following internal optical drive options:

Table 10. Supported optical drive

DVD	DESCRIPTION	(1U)
OPTICALS - DVD	DVD-ROM, 9.5mm, SATA, HLDS (internal)	v
OPTICALS - DVD	DVDRW,9.5mm, SATA, HLDS (internal)	v
OPTICALS - DVD	DVD-ROM,9.5mm, SATA, PLDS (internal)	v
OPTICALS - DVD	DVDRW, 9.5mm, SATA, PLDS (internal)	v
OPTICALS - DVD	DVD-ROM, USB, HLDS, (EXTERNAL)	v

External Storage

The following table shows the supported external storage for the PowerEdge R6515:

Table 11. Supported external storage

Device Type	Description
External Tape	Supports connection to external USB tape products
NAS/IDM appliance software	Supports NAS software stack
JBOD	Supports connection to 12Gb MD-series JBODs

Networking and PCIe

The PowerEdge R6515 system offers balanced, scalable I/O capabilities, including integrated PCIe 3.0-capable expansion slots. Dell's LOM riser card and Dell Select Network Adapters let you choose the right network fabric without using up a valuable PCI slot. Pick the speed, technology, vendor, and other options, such as switch-independent partitioning to share and manage bandwidth on 10 GbE connections.

The PowerEdge R6515 system supports two Network Interface Controller (NIC) ports on the back panel, which are available in the following configurations:

- 2 x 1 GbE
- 2 x 10 GbE
- 2 x 10Gb SFP+
- 2 x 25Gb SFP+

Table 12. Optional add-in PCIe expansion NIC for R6515

Type	Adapter
NIC	<ul style="list-style-type: none"> • BCM5720L • BCM57416 • 2 x 1 Gb BASE-T • 2 x 10 Gb BASE-T • 2 x 10 Gb SFP+

Topics:

- [Expansion card installation guidelines](#)

Expansion card installation guidelines

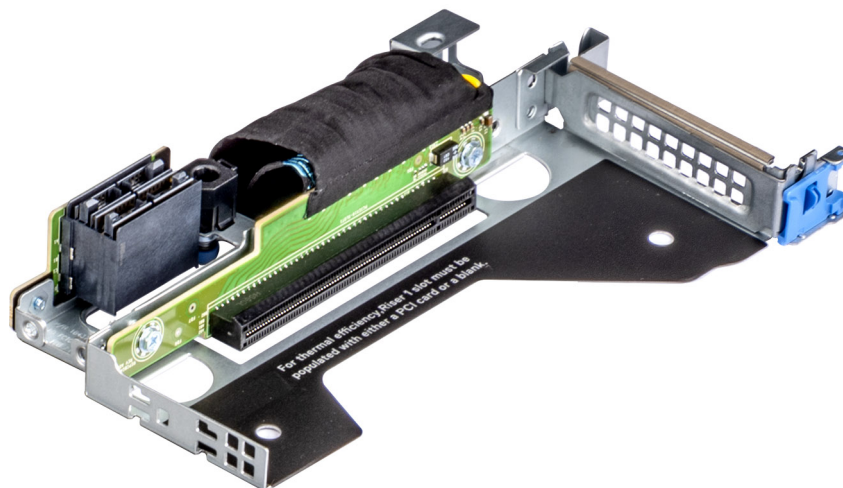

Figure 7. Riser 1A

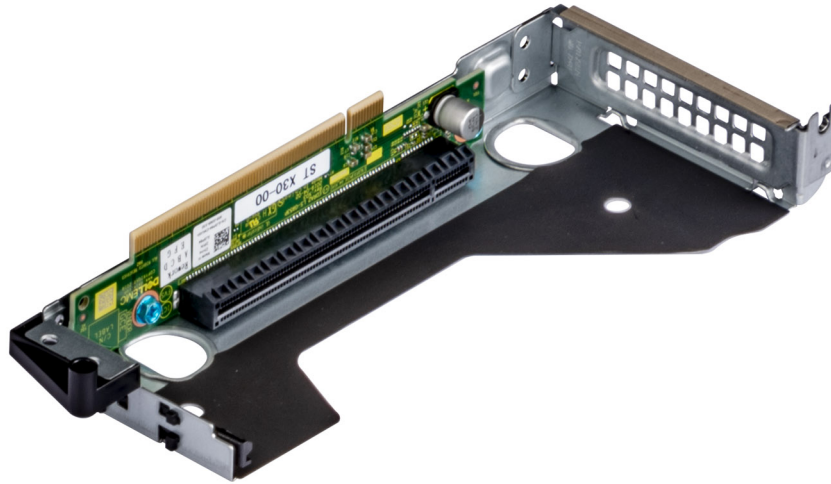

Figure 8. Riser 2

The following table describes the supported expansion cards:

Table 13. Expansion card riser configurations

Expansion card riser	PCIe slots on the riser	Processor connection	Height	Length	Slot width
No riser	Slot 1	Processor 1	-	-	x8
Riser 1A	Slot 2	Processor 1	Low Profile	Half Length	x16
Riser 2	Slot 3	Processor 1	Low Profile	Half Length	x16

NOTE: The expansion-card slots are not hot-swappable.

The following table provides guidelines for installing expansion cards to ensure proper cooling and mechanical fit. The expansion cards with the highest priority should be installed first, using the slot priority indicated. All the other expansion cards should be installed in the card priority and slot priority order.

Table 14. No riser configuration (Slot 1)

Card type	Slot priority	Maximum number of cards
PERC9 (H330, HBA 330, H730P)	Internal Slot	1
PERC10 (H740P)	Internal Slot	1
LOM Riser (1G/10G/25G)	1	1

Table 15. Riser configuration (include slots 1 and 2)

Card type	Slot priority	Maximum number of cards
PERC9 (H330, HBA 330, H730P)	Internal Slot	1
PERC10 (H740P)	Internal Slot	1
NVME PCIE SSD	2	1
Broadcom (1G DP/1G QP)	2	1
Broadcom (10G DP)	2	1
Broadcom (25G DP)	2	1
Intel 10G (BaseT DP/QP)	2	1

Card type	Slot priority	Maximum number of cards
Intel 10G (SFP+ DP/QP)	2	1
Intel 1G (DP/QP)	2	1
Emulex (FC32 2P)	2	1
Emulex (FC16 1P)/(FC16 2P)	2	1
Emulex (FC8 SC)/(FC8 DLC)	2	1
Mellanox 10G, CXP DP SFP	2	1
Mellanox 25G, CX4LX DP SFP	2	1
Qlogic 10G BASET DP	2	1
Qlogic 10G SFP+ DP	2	1
Qlogic 25G SFP DP	2	1
Qlogic (FC8 DCL)	2	1
Qlogic (FC16 SP/DP)	2	1
Qlogic (FC32 DP)	2	1
LOM Riser (2x1G)/(2x10G)/(2x25G)	1	1

Table 16. Riser configuration (include slots 1,2, and 3)

Card type	Slot priority	Maximum number of cards
PERC9 (H330, HBA 330, H730P)	Internal Slot	1
PERC10 (H740P)	Internal Slot	1
NVME PCIE SSD	2,3	2
Broadcom (1G DP/1G QP)	2,3	2
Broadcom (10G DP)	2,3	2
Broadcom (25G DP)	2,3	2
Intel 10G (BaseT DP/QP)	2,3	2
Intel 10G (SFP+ DP/QP)	2,3	2
Intel 1G (DP/QP)	2,3	2
Emulex (FC32 2P)	2,3	2
Emulex (FC16 1P)/(FC16 2P)	2,3	2
Emulex (FC8 SC)/(FC8 DLC)	2,3	1
Mellanox 10G, CXP DP SFP	2,3	2
Mellanox 25G, CX4LX DP SFP	2,3	2
Qlogic 10G BASET DP	2,3	2
Qlogic 10G SFP+ DP	2,3	2
Qlogic 25G SFP DP	2,3	2
Qlogic (FC8 DCL)	2,3	2
Qlogic (FC16 SP/DP)	2,3	2
Qlogic (FC32)	2,3	2
LOM Riser (2x1G)/(2x10G)/(2x25G)	1	1

Power, thermal, and acoustics

Power

PowerEdge R6515 has an extensive collection of sensors that automatically track thermal activity, which helps regulate temperature and reduce server noise and power consumption.

Table 17. Power tools and technologies

Feature	Description
Power Supply Units (PSU) portfolio	Dell EMC's PSU portfolio includes intelligent features such as dynamically optimizing power usage while maintaining availability and redundancy. Find additional information in the Power supply units section.
Tools for right sizing	Energy Smart Solution Advisor (ESSA) is a tool that can help determine the most efficient configuration possible. ESSA can calculate the power consumption of hardware, power infrastructure, and storage. ESSA can help to determine exactly how much power a server will use on a given workload, and the PSU Advisor can help to choose the best, most efficient PSU. Learn more at Dell.com/calc . Energy Smart Data Center Assessment is a Dell Services offering that uses infrastructure and thermal analysis to help maximize system efficiency. Learn more at Dell.com/EnergySmart .
Industry Compliance	Dell EMC servers are compliant with all relevant industry certifications and guidelines, including 80 PLUS, Climate Savers, and ENERGY STAR.
Power monitoring accuracy	PSU power monitoring improvements include: <ul style="list-style-type: none"> • Power monitoring accuracy is currently 1%, whereas the industry standard is 5% • More accurate reporting of power • Better performance under a power cap
Power capping	Use Dell EMC's systems management to set the power cap limit for your systems to limit the output of a PSU and reduce system power consumption.
Systems Management	iDRAC Enterprise provides server- level management that monitors, reports, and controls power consumption at the processor, memory, and system level. Dell OpenManage Power Center delivers group power management at the rack, row, and data center level for servers, power distribution units, and uninterruptible power supplies.
Active power management	Node Manager is an embedded technology that provides individual server- level power reporting and power limiting functionality. Hot spare reduces power consumption of redundant power supplies.
Fresh Air cooling	Learn more at Dell.com/fresh-air-cooling
Rack infrastructure	Dell EMC offers some of the industry's highest- efficiency power infrastructure solutions, including: <ul style="list-style-type: none"> • Power distribution units (PDUs) • Uninterruptible power supplies (UPSs) • Energy Smart containment rack enclosures Find additional information at: http://content.dell.com/us/en/enterprise/power-and-cooling-technologies-components-rack-infrastructure.aspx .

Thermal

The thermal design of the PowerEdge R6515 reflect the following:

- Optimized thermal design: The system layout is architected for optimum thermal design.

- System component placement and layout are designed to provide maximum airflow coverage to critical components with minimum expense of fan power.
- Comprehensive thermal management: The thermal control system regulates the fan speed based on several different responses from all system- component temperature sensors, as well as inventory for system configurations. Temperature monitoring includes components such as processors, DIMMs, chipset, the inlet air ambient, hard disk drives, and LOM Riser.
- Open and closed loop thermal fan speed control: Open loop thermal control uses system configuration to determine fan speed based on inlet air ambient temperature. Closed loop thermal control method uses feedback temperatures to dynamically determine proper fan speeds.
- User-configurable settings: With the understanding and realization that every customer has unique set of circumstances or expectations from the system, in this generation of servers, we have introduced limited user- configurable settings residing in the iDRAC9 BIOS setup screen.

Cooling redundancy: The R6515 allow N+1 fan redundancy, allowing continuous operation with one fan failure in the system.

Acoustics

The acoustical design of the PowerEdge R6515 reflect the following:

- Versatility: The PowerEdge R6515 reduce power draw in the data center and are also quiet enough for office environment in typical and minimum configurations. The system is sufficiently quiet where the sound blends into the environment.
- Adherence to Dell's high sound quality standards: Sound quality is different from sound power level and sound pressure level in that it describes how humans respond to annoyances in sound, like whistles and hums. One of the sound quality metrics in the Dell specifications is prominence ratio of a tone.
- Noise ramp and descent at boot-up from power-off: Fan speeds and noise levels ramp during the boot process (from power- off to power- on) in order to add a layer of protection for component cooling in the event that the system was not able to boot properly. In order to keep the boot-up process as quiet as possible, the fan speed reached during boot-up is limited to about half of full speed.
- Noise level dependencies: If acoustics is important to you, then you should consider several configuration choices and settings:
 - For lower acoustical output, use a small number of lower rotational- speed SATA hard drives, nearline SAS hard drives, or non-rotational devices like SSDs. 15k hard drives generate more acoustic noise than lower rotational- speed hard drives, Also noise increases with number of hard drives.
 - Fan speeds and noise may increase from baseline factory configurations if certain profiles are changed by the user or the system configurations are updated. The following is a list of items that impact fan speeds and acoustical output:
 - iDRAC9 BIOS settings: Performance Per Watt (DAPC or OS) may be quieter than Performance or Dense Configuration (iDRAC Settings > Thermal > Max. Exhaust Temperature or Fan speed offset).
 - The quantity and type of PCIe cards installed: This affects overall system acoustics. Installation of more than two PCIe cards results in an increase in overall system acoustics.
 - Using a GPU card: This results in an increase in overall system acoustics.
 - PCIe controller-based SSD drives: Drives such as Express flash drives and Fusion- IO cards require greater airflow for cooling, and result in significantly higher noise levels.
 - Systems with an H330 PERC: This configuration may be quieter than those with an H740P PERC with battery backup. However, higher noise levels result when a system is configured as non-RAID.
 - Hot spare feature of power supply unit: In the system default setting, the Hot Spare Feature is disabled; acoustical output from the power supplies is lowest in this setting.

Supported operating systems

The list below contains the primary operating systems supported on R6515:

- Windows Server 2016
- Windows Server 2019
- RedHat Enterprise Linux
- SUSE Linux
- VMware vSphere

For more information on the specific versions and additions, see <https://www.dell.com/support/home/Drivers/SupportedOS/poweredge-r6515>

Dell EMC OpenManage systems management

Whether your IT environment consists of a few servers or a few thousand servers, Dell EMC OpenManage systems management solutions provide comprehensive management for evolving IT environments. OpenManage is based on open standards and provides agent-based and agent-free server lifecycle management functionality for Dell EMC PowerEdge servers. OpenManage solutions help you automate and streamline essential hardware management tasks.

Start with a firm foundation for efficient hardware management using OpenManage tools, utilities and management consoles. OpenManage systems management solutions consist of a combination of embedded management features and software products that help you automate and simplify the entire server lifecycle: deploy, update, monitor and maintain. OpenManage solutions are innovatively designed for simplicity and ease of use to help you reduce complexity, save time, achieve efficiency, control costs and empower productivity. OpenManage centers around efficient management of server lifecycle.

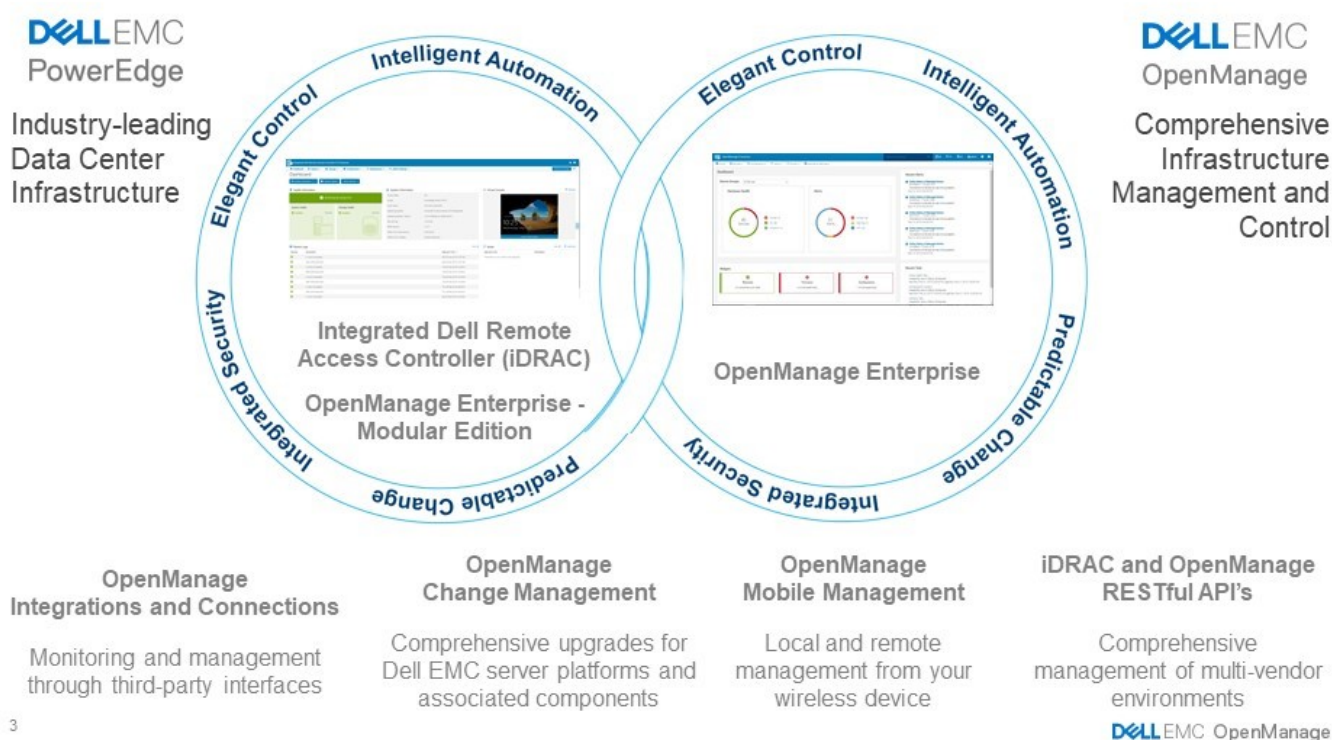

Figure 9. Server lifecycle management operations

Topics:

- [iDRAC9 with Lifecycle Controller](#)
- [Agent-free management](#)
- [Agent-based management](#)
- [Dell EMC consoles](#)
- [Dell EMC OpenManage systems management tools, utilities and protocols](#)
- [Integration with third-party consoles](#)
- [OpenManage connections with third-party consoles](#)

iDRAC9 with Lifecycle Controller

The Integrated Dell Remote Access Controller 9 (iDRAC9) with Lifecycle Controller, the embedded intelligence of every Dell EMC PowerEdge new generation server, helps you manage Dell EMC servers agent-free or with a systems management agent, within physical,

virtual, local and remote environments. iDRAC9 alerts server issues, enables remote server management and reduces the need to physically visit the server. iDRAC9 with Lifecycle Controller is part of Dell EMC comprehensive OpenManage portfolio and works as a stand-alone or in conjunction with other components such as OpenManage Essentials, OpenManage Mobile, OpenManage Power Center, Chassis Management Controller, and OpenManage Integrations for Microsoft, VMware and BMC consoles to simplify, automate and streamline IT operations.

Dell EMC BMC and iDRAC9 feature comparison

iDRAC9 Enterprise is available for the system. Dell EMC also offers BMC. A detailed feature comparison for Dell EMC BMC and iDRAC9 Express is shown in the following table

Table 18. Feature comparison for Dell EMC BMC and iDRAC9 Enterprise

Feature	Dell EMC BMC	iDRAC9 Enterprise
<i>Interfaces / Standards</i>		
IPMI 2.0	Yes	Yes
DCMI 1.5	Yes	Yes
Web-based GUI	Yes	Yes
Racadm command line (local/remote)	Yes	Yes
SMASH-CLP (SSH-only)	Yes	Yes
Telnet	Yes	Yes
SSH	Yes	Yes
WSMAN	Yes	Yes
RedFish API	Yes	Yes
Network Time Protocol	Yes	Yes
<i>Connectivity</i>		
Shared NIC	Yes	Yes
Dedicated NIC (with Ports card)	Yes	Yes
VLAN tagging	Yes	Yes
IPv4	Yes	Yes
IPv6	Yes	Yes
DHCP	Yes	Yes
Dynamic DNS	Yes	Yes
OS pass-through	Yes	Yes
<i>Security</i>		
Role-based authority	Yes	Yes
Local users	Yes	Yes
SSL encryption	Yes	Yes
IP blocking	Yes	Yes
Directory services (AD, LDAP)	No	Yes
Two-factor authentication	No	Yes
Single sign-on	No	Yes
PK authentication	Yes	Yes
New generation: Configuration Lockdown	No	Yes
New generation: System Erase of internal storage devices	Yes	Yes
<i>Remote Presence</i>		

Feature	Dell EMC BMC	iDRAC9 Enterprise
Power control	Yes	Yes
Boot control	Yes	Yes
Serial-over-LAN	Yes	Yes
Virtual Media	No	Yes
Virtual Folders	No	Yes
Remote File Share	No	Yes
Virtual Console	Yes	Yes
VNC connection to OS	No	Yes
Quality/bandwidth control	No	Yes
Virtual Console collaboration (6 users)	No	Yes
Virtual Console chat	No	Yes
<i>Power & Thermal</i>		
Real-time power meter	Yes	Yes
Power thresholds & alerts	Yes	Yes
Real-time power graphing	Yes	Yes
Historical power counters	Yes	Yes
Power capping	Yes	Yes
Power Center integration	Yes	Yes
Temperature monitoring	Yes	Yes
Temperature graphing	Yes	Yes
<i>Health Monitoring</i>		
Full agent-free monitoring	Yes	Yes
Predictive failure monitoring	Yes	Yes
SNMPv1, v2, and v3 (traps and gets)	Yes	Yes
Email Alerting	Yes	Yes
Configurable thresholds	Yes	Yes
Fan monitoring	Yes	Yes
Power Supply monitoring	Yes	Yes
Memory monitoring	Yes	Yes
CPU monitoring	Yes	Yes
RAID monitoring (PERC)	Yes	Yes
NIC monitoring	Yes	Yes
HD monitoring ((including JBOD enclosure)	Yes	Yes
Out of Band Performance Monitoring	No	Yes
<i>Update</i>		
Remote agent-free update	Yes	Yes
Embedded update tools	No	Yes
Sync with repository (scheduled updates)	No	Yes
Auto-update	No	Yes
<i>Deployment & Configuration</i>		

Feature	Dell EMC BMC	iDRAC9 Enterprise
Embedded OS deployment tools	No	Yes
Embedded configuration tools	No	Yes
Auto-Discovery	No	Yes
Remote OS deployment (vMedia)	No	Yes
Embedded driver pack	Yes	Yes
Full configuration inventory	Yes	Yes
Inventory export	Yes	Yes
Remote configuration	Yes	Yes
Zerotouch configuration	No	Yes
System Retire/Repurpose	Yes	Yes
New generation: iDRAC Connection View	No	Yes
New generation: BIOS configuration page in iDRAC GUI	Yes	Yes
<i>Diagnostics, Service, & Logging</i>		
Embedded diagnostic tools	Yes	Yes
Part Replacement	No	Yes
Server Configuration Backup	No	Yes
Server Configuration Restore	Yes	Yes
Easy Restore (system configuration) - USB and rSPI	Yes	Yes
Health LED only	Yes	Yes
New generation: Quick Sync 2.0	NA	NA
New generation: iDRAC Direct 2.0 (micro USB port on rear)	Yes	Yes
iDRAC Service Module (iSM)	Yes	Yes
Embedded Tech Support Report	Yes	Yes
Crash screen capture	No	Yes
Crash video capture (requires iSM or OMSA)	No	Yes
Boot capture	No	Yes
Manual reset for iDRAC	Yes	Yes
Virtual NMI	Yes	Yes
OS watchdog (requires iSM or OMSA)	Yes	Yes
System Event Log	Yes	Yes
Lifecycle Log	Yes	Yes
Work notes	Yes	Yes
Remote Syslog	No	Yes
License management	Yes	Yes

Agent-free management

As Dell EMC PowerEdge servers have embedded server lifecycle management, in many cases, there is no need to install an OpenManage systems management software agent into the operating system of a Dell EMC PowerEdge server. This greatly simplifies and streamlines the management footprint.

Agent-based management

Most systems management solutions require pieces of software, called agents, to be installed on each node in order to be managed within the IT environment. Additionally, the same agent is often used as a local interface into the hardware health and may be accessed remotely as a management interface, typically referred to as a one-to-one interface. For customers that continue to use agent-based solutions, Dell EMC provides OpenManage Server Administrator.

Dell EMC consoles

The central console in a systems management solution is often referred to as the one-to-many console. The central console provides a rapid view and insight into the overall health of all systems in the IT environment. The Dell EMC systems management portfolio includes several powerful consoles, depending upon your needs, including the following:

Dell EMC OpenManage Enterprise

Dell EMC OpenManage Enterprise is an intuitive infrastructure management console. It is designed to take the complexity out of IT infrastructure management. It delivers better results with less time and fewer steps. OpenManage Enterprise helps IT professions balance time and energy between complex IT infrastructure and business goals.

Simplify

- Robust, intuitive management capabilities regardless of form factor.
- OpenManage Enterprise reduces learning time with HTML5 GUI with elastic search engine. It navigates to critical information and tasks easier and quicker. The automatable processes, templates and policies can be created and edited through a simple menu-driven method.

Unify

- One-to-many management from a single console: built for scale.
- OpenManage Enterprise supports up to 8,000 devices regardless of form factors. It supports Dell EMC PowerEdge racks, towers, and modular servers. It also monitors and creates alerts for third-party devices or PowerVault MD and ME Storage systems.

Automated

- Automated IT processes for greater efficiency
- From discovery to retirement, activities can be managed in the same console. In minutes, devices can be deployed automatically with templates based on service tags or node IDs.

Secure

- Designed for security throughout the infrastructure lifecycle.
- Security is always the top priority. To protect your infrastructure, OpenManage Enterprise detects drift from a user-defined configuration template, alerts users, and remediates misconfigurations based on pre-setup policies.

For more information, see [Dell OpenManage Enterprise page](#)

OpenManage Mobile

OpenManage Mobile(OMM) is a software application that enables easy, convenient, and secure monitoring and management of PowerEdge servers remotely, or at-the-server. With OpenManage Mobile, IT Administrators can securely perform several data center monitoring and remediation tasks using an Android or iOS mobile device. The OpenManage Mobile app is available as a free software download from the Apple Store and the Google Play Store.

OMM can also monitor and manage PowerEdge servers through a OpenManage Essentials console or by directly accessing the server's iDRAC.

The OpenManage Essentials console can be accessed through OpenManage Mobile over a secure IP network. This allows you to monitor all devices managed by OpenManage Essentials such as Dell EMC servers, storage, networking, firewall, and supported third party devices.

If you are remote, you can access iDRAC over a secure IP network.

Key Features of OpenManage Mobile (When connected through OpenManage Essentials console):

- Connect to multiple servers which have OME installed, from a single mobile device
- Connect to multiple servers individually through the iDRAC interface
- Receive critical alert notification on your mobile device as they arrive into your OpenManage Essentials management console
- Acknowledge, forward, and delete alerts from your mobile device
- Browse through device details, firmware inventory, and event logs of individual systems
- Perform several server management functions such as power-on, power cycle, reboot, and shutdown from the mobile application

Key Features of OpenManage Mobile (When connected through iDRAC):

- Connect to any previous generation PowerEdge servers remotely
- Assign IP address, change credentials, and update common BIOS attributes for Bare Metal Configuration
- Configure one server manually, or multiple servers simultaneously through a template
- Browse server details, health status, hardware & firmware inventory, networking details, and System Event or LC logs. Share this information easily with other IT Administrators
- Access SupportAssist reports, Last Crash screen and video (previous and current generation PowerEdge servers)
- Access Virtual Console (and reduce the need for crash carts)
- Power On, Shut down, or Reboot your server from anywhere
- Run any RACADM command

OpenManage Enterprise Power Manager

OpenManage Enterprise Power Manager is a plugin for OpenManage Enterprise V3.2 and later. Power Manager provides monitoring and management at a one to many levels of server power and thermal. The features of Power Manager are:

- Measure and manage power consumption and monitors thermal readings — OME Power Manager provides greater insight into a data center's energy usage through detailed measurement of energy consumption throughout a data center. Power Manager gives administrators the ability to measure and manage the power consumption of up to 3,000 servers and track both short-term and long-term historical data.
- Create and implement multiple usage policies—Power Manager simplifies implementation of power policies across a data center. When it is used with the previous generation or later versions of the PowerEdge servers, OpenManage Enterprise Advanced license and an iDRAC Enterprise license, administrators can control power consumption to each row, rack, or group of PE servers. In addition, administrators can create reports on energy usage and thermal readings on a group-by-group basis.
- Reduce consumption during low-load hours—Power Manager helps administrators to save power by allowing management of a server room according to business needs. Power Manager allows administrators to implement policies that reduce the power consumption when the demand on the systems is lower. It can also assign maximum power to the servers that run the most important applications.

For more information, see [OpenManage Enterprise Power Manager User's Guide](#).

Dell EMC OpenManage systems management tools, utilities and protocols

Dell EMC OpenManage systems management tools and utilities consist of the following:

Dell EMC Repository Manager:

Dell EMC Repository Manager (DRM) is an application that helps you to:

- Identify the updates that are relevant to the systems in your data center
- Identify and notify when updates are available
- Package the updates into different deployment format

To automate the creation of baseline repositories, DRM provides advanced integration capabilities with iDRAC/LC, OpenManage Essentials, Chassis Management Controller, OpenManage Integration for VMware vCenter and OpenManage Integration for Microsoft System Center (OMIMSSC). Also, DRM packages updates into custom catalogs that can be used for deployment.

Dell EMC Repository Manager can create the following deployment tools:

- Custom catalogs
- Lightweight deployment pack
- Bootable Linux ISO
- Custom Server Update Utility (SUU)

For more information, see Dell EMC Repository Manager User's Guide available at Dell.com/support/manuals.

Dell Update Packages

Dell Update Packages (DUP) is a self-contained executable supported by Microsoft Windows or Linux that updates a component on a server and applications like OMSA, iSM, and DSET.

DUPs can be executed in GUI or in CLI mode.

For more information, see Dell EMC Update Packages User's Guide available at www.delltechcenter.com/DSU.

Dell Remote Access Controller Administration (RACADM) CLI

The RACADM command-line utility provides a scriptable interface to perform inventory, configuration, update, and health status check of PowerEdge servers. RACADM operates in multiple modes:

- Local — supports running RACADM commands from the managed server's operating system.
- SSH or Telnet — known as Firmware RACADM; is accessible by logging in to iDRAC using SSH or Telnet
- Remote — supports running RACADM commands from a remote management station such as a laptop or desktop

RACADM is supported by the iDRAC with Lifecycle Controller and by the Chassis Management Controller of the M1000e, VRTX and FX2 modular systems. Local and Remote RACADM is supported on Windows Server, Windows clients, and on Red Hat, SuSe and Ubuntu Linux.

For more information, see the RACADM Command Line Reference Guide for iDRAC and CMC available at Dell.com/support/manuals.

iDRAC with Lifecycle Controller Embedded Management APIs

iDRAC with Lifecycle Controller provides a range of standards-based applications programming interfaces (APIs) that enable scalable and automated management of PowerEdge servers. Standard systems management APIs have been developed by organizations such as the Institute of Electrical and Electronics Engineers (IEEE) and Distributed Management Task Force (DMTF). These APIs are widely used by commercial systems management products and by custom programs and scripts developed by IT staff to automate management functions such as discovery, inventory, health status checking, configuration, update, and power management. The APIs supported by iDRAC with Lifecycle Controller include:

- **Redfish** - In 2015, the DMTF Scalable Platforms Management Forum published Redfish, an open industry-standard specification and schema designed to meet the needs of IT administrators for simple, modern, and secure management of scalable platform hardware. Dell is a key contributor to the Redfish standard, acting as co-chair of the SPMF, promoting the benefits of Redfish, and working to deliver those benefits within industry-leading systems management solutions. Redfish is a next generation management standard using a data model representation inside a hypermedia RESTful interface. The data model is defined in terms of a standard, machine-readable schema, with the payload of the messages expressed in JSON and the OData v4 protocol.
- **WSMan** - The Web Services For Management (WSMan) API, first published by the DMTF in 2008, is the most mature and robust API provided by iDRAC with Lifecycle Controller. WSMan uses a Simple Object Access Protocol (SOAP) with data modeled using the Common Information Model. WSMan provides interoperability between management applications and managed resources, and identifies a core set of web service specifications and usage requirements that expose a common set of operations central to all systems management.
- **IPMI** - The Intelligent Platform Management Interface (IPMI) is a message-based, hardware-level interface specification that can operate over both LAN and serial interfaces. IPMI is supported broadly by server vendors, systems management solutions, and open source software.
- **SNMP** - The Simple Network Management Protocol (SNMP) helps in standardizing the management of network devices. SNMP allows commercial management consoles created for monitoring network switches and routers to also monitor X86 servers. SNMP is primarily used to deliver event messages to alert administrators of problems on their systems but can also be used to discover, inventory and configure servers.

To assist automating system management tasks and simplify API integration, Dell provides PowerShell and Python libraries and script examples utilizing the WSMan interface. The iDRAC with LC pages of Dell Techcenter offer a library of technical white papers detailing the use of the embedded management APIs. For more information, see delltechcenter.com/iDRAC and delltechcenter.com/LC.

Integration with third-party consoles

Dell EMC OpenManage provides integration with several leading third-party consoles, including:

OpenManage Integration Suite for Microsoft System Center

The combination of Dell OpenManage Integration Suite and Microsoft System Center simplifies and enhances deployment, configuration, monitoring and updating of Dell servers and storage in physical and virtual environments. Our agent-free and agent-based plug-ins deliver a unique level of integration and efficiency when managing Dell hardware within a System Center environment.

The OpenManage Integration Suite for Microsoft System Center includes: Dell Server and Storage Management Packs for System Center Operations Manager (SCOM); Dell Server Deployment Packs and Update Catalogs for System Center Configuration Manager (SCCM); and tools for optimizing management of Dell PowerEdge servers in virtual environments using System Center Virtual Machine Manager (SCVMM).

OpenManage Integration for VMware vCenter

The OpenManage Integration for VMware vCenter allows you to monitor, provision, and manage PowerEdge server hardware and firmware. You can perform these tasks through a dedicated Dell menu that can be accessed directly through the VMware vCenter console. OMIVV also allows granular control and reporting for the hardware environment using the same role-based access control model as vCenter. The OpenManage Management Pack for vRealize Operations Manager is available with OMIVV v4.0 onwards. This helps in checking hardware health and alerting into vRealize operations, which also includes dashboard and reporting on the server environment.

You can manage and monitor Dell hardware within the virtualized environment

- Alerting and monitoring environment for servers and chassis
- Monitoring and reporting for servers and chassis
- Updating firmware on servers
- Deploying enhanced options

For more information, see delltechcenter.com/omivv

NOTE: The Dell EMC Repository Manager integrates with OpenManage Integration for VMware vCenter. The Dell EMC Repository Manager provides advanced functionality, simplifies the discovery, and deployment of new updates.

BMC Software

Dell EMC and BMC Software work together to simplify IT by ensuring tight integration between Dell EMC server, storage, and network management functionality and the BMC Software process and data center automation products.

OpenManage connections with third-party consoles

Dell EMC OpenManage Connections gives you an easy path to adding support for third-party devices, so you can continue to use your existing management tools while easily adding Dell EMC server systems to your existing IT environment. Integrate new systems at your own pace. Manage new Dell EMC servers and storage with your legacy management tools, while extending the useful life of your existing resources. With OpenManage Connections you can add monitoring and troubleshooting of Dell EMC assets to your IT infrastructure.

- OpenManage Connection for Nagios Core and Nagios XI
- OpenManage Connection for HPE Operations Manager i (OMi)

For more information on these OpenManage Connections, visit Dell.com/openmanage.

Appendix A. Additional specifications

Chassis dimensions

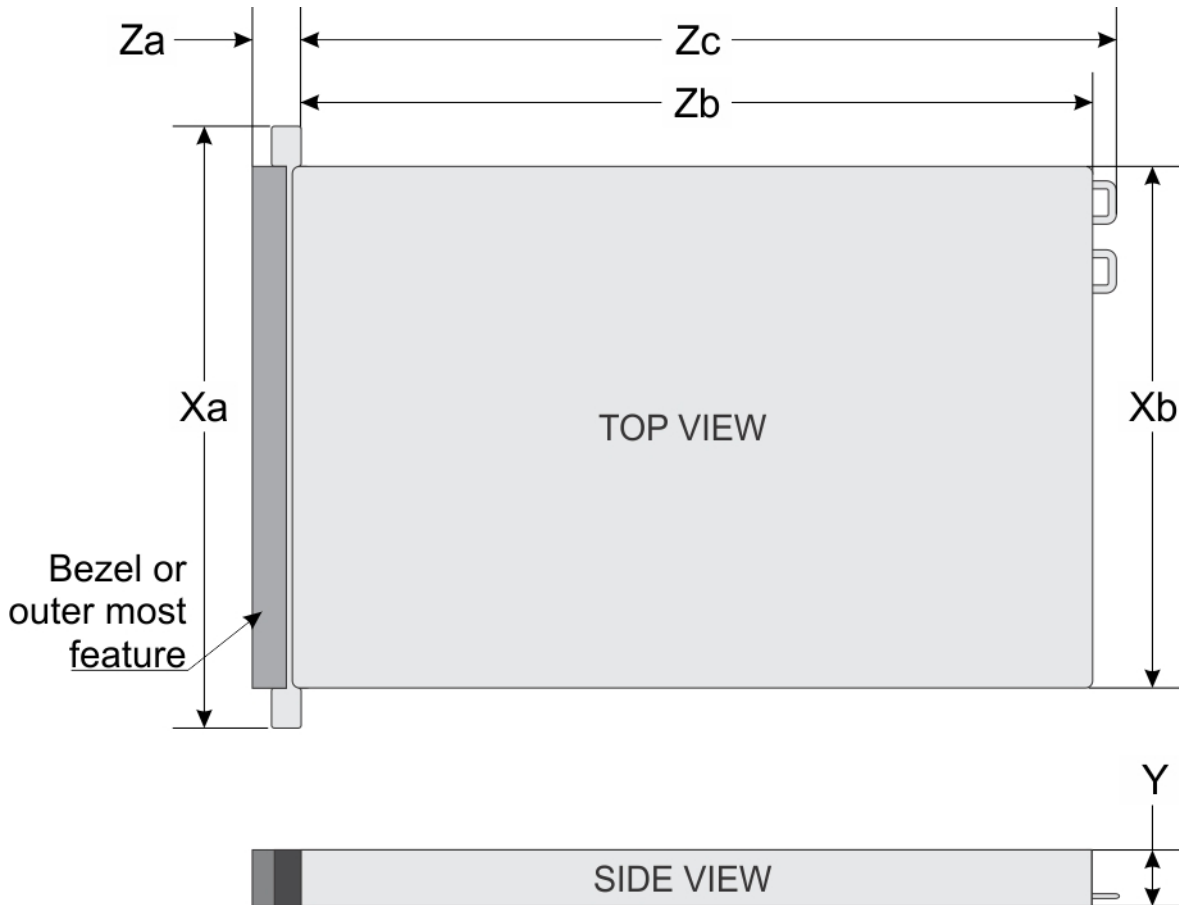

Figure 10. Chassis dimensions

Table 19. PowerEdge R6515 chassis dimensions

System configurations	Xa	Xb	Y	Za	Zb*	Zc
4 x 3.5-inches or 10 x 2.5-inches	482.0 mm (18.97 inches)	434.0 mm (17.08 inches)	42.8 mm (1.68 inches)	With bezel: 35.84 mm (1.4 inches) Without bezel: 22.0 mm (0.87 inches)	657.25 mm (25.87 inches)	692.62 mm (27.26 inches)
8 x 2.5-inches	482.0 mm (18.97 inches)	434.0 mm (17.08 inches)	42.8 mm (1.68 inches)	With bezel: 35.84 mm (1.4 inches) Without bezel: 22.0 mm (0.87 inches)	606.47 mm (23.87 inches)	641.85 mm (25.26 inches)

NOTE: * Zb goes to the nominal rear wall external surface where the motherboard I/O connectors reside.

Chassis weight

Table 20. PowerEdge R6515 system weight

System configuration	Maximum weight (with all drives/SSDs)
4 x 3.5-inch configuration	16.75 kg (36.92 lb)
8 x 2.5-inch configuration	15.6 kg (34.39 lb)
10 x 2.5-inch configuration	15.8 kg (34.83 lb)

Video

The PowerEdge R6515 system supports integrated Matrox G200eR2 graphics controller with 16 MB of video frame buffer.

Table 21. Supported front video resolution options

Resolution	Refresh rate (Hz)	Color depth (bits)
1024 x 768	60	8, 16, 32
1280 x 800	60	8, 16, 32
1280 x 1024	60	8, 16, 32
1360 x 768	60	8, 16, 32
1440 x 900	60	8, 16, 32

Table 22. Supported rear video resolution options

Resolution	Refresh rate (Hz)	Color depth (bits)
1024 x 768	60	8, 16, 32
1280 x 800	60	8, 16, 32
1280 x 1024	60	8, 16, 32
1360 x 768	60	8, 16, 32
1440 x 900	60	8, 16, 32
1600 x 900	60	8, 16, 32
1600 x 1200	60	8, 16, 32
1680 x 1050	60	8, 16, 32
1920 x 1080	60	8, 16, 32
1920 x 1200	60	8, 16, 32

USB

Front, rear, and internal USB ports are included in the base system for R6515. Rear ports support up to USB 3.1 Gen1, internal port supports up to USB 3.1 Gen1, and front ports support USB 2.0.

Environmental specifications

The following tables illustrates the environmental specifications for the PowerEdge R6515:

Table 23. Temperature specifications

Temperature	Specifications
Storage	-40°C to 65°C (-40°F to 149°F)
Continuous operation(for altitude less than 950m or 3117ft)	10°C to 35°C (50°F to 95°F) with no direct sunlight on the equipment <i>i</i> NOTE: Certain system configurations may require reductions in the upper temperature limits. <i>i</i> NOTE: The performance of the system may be impacted when operating above the upper temperature limit or with a faulty fan.
Fresh air	For information about Fresh Air see Expanded operating temperature table
Maximum temperature gradient (operating and storage)	20°C/h (68°F/h)

Table 24. Relative humidity specifications

Relative Humidity	Specifications
Storage	5% to 95% RH with 33°C (91°F) maximum dew point. Atmosphere must be non-condensing at all times.
Operating	10% to 80% relative humidity with 29°C (84.2°F) maximum dew point.

Table 25. Maximum vibration specifications

Maximum vibration	Specifications
Operating	0.26Grms at 5Hz to 350Hz (x, y, and z axes)
Storage	1.88Grms at 10Hz to 500Hz for 15min (all six sides tested)

Table 26. Maximum shock specifications

Maximum shock	Specifications
Operating	Six consecutively executed shock pulses in the positive and negative x, y, and z axes of 6G for up to 11ms
Storage	Six consecutively executed shock pulses in the positive and negative x, y, and z axes (one pulse on each side of the system) of 71 G for up to 2 ms.

Table 27. Maximum altitude specifications

Maximum altitude	Specifications
Operating	3048m (10,000 ft)
Storage	12,000m (39,370 ft)

Table 28. Operating temperature de-rating specifications

Operating temperature de-rating	Specifications
Up to 35°C (95°FJ)	Maximum temperature is reduced by 1°C/300 m (1°F/547 ft) above 950 m (3,117 ft).
35°C to 40°C (95°F to 104°FJ)	Maximum temperature is reduced by 1°C/175 m (1°F/319 ft) above 950 m (3,117 ft).
40°C to 45°C (104°F to 113°FJ)	Maximum temperature is reduced by 1°C/125 m (1°F/228 ft) above 950 m (3,117 ft).

Table 29. Standard operating temperature

Standard operating temperature	Specifications
Continuous operation (for altitude less than 950m or 3117ft)	10°C to 35°C (50°F to 95°F) with no direct sunlight on the equipment.

Table 30. Expanded operating temperature

Expanded operating temperature	Specifications
Continuous operation	<p>5°C to 40°C at 5% to 85% RH with 29°C dew point.</p> <p>NOTE: Outside the standard operating temperature (10°C to 35°C), the system can operate continuously in temperatures as low as 5°C and as high as 40°C.</p> <p>For temperatures between 35°C and 40°C, de-rate maximum allowable temperature by 1°C per 175 m above 950 m (1°F per 319 ft).</p>
1% of annual operating hours	<p>-5°C to 45°C at 5% to 90% RH with 29°C dew point.</p> <p>NOTE: Outside the standard operating temperature (10°C to 35°C), the system can operate down to -5°C or up to 45°C for a maximum of 1% of its annual operating hours.</p> <p>For temperatures between 40°C and 45°C, de-rate maximum allowable temperature by 1°C per 125 m above 950 m (1°F per 228 ft).</p>

NOTE: When operating in the expanded temperature range, system performance may be impacted.

NOTE: When operating in the expanded temperature range, ambient temperature warnings maybe reported on the LCD panel and in the System Event Log.

Appendix B. Standards compliance

The system conforms to the following industry standards.

Table 31. Industry standard documents

Standard	URL for information and specifications
ACPI Advance Configuration and Power Interface Specification, v2.0c	acpi.info
Ethernet IEEE 802.3-2005	standards.ieee.org/getieee802/802.3.html
HDG Hardware Design Guide Version 3.0 for Microsoft Windows Server	microsoft.com/whdc/system/platform/pcdesign/designguide/serverdg.mspx
IPMI Intelligent Platform Management Interface, v2.0	intel.com/design/servers/ipmi
DDR4 Memory DDR4 SDRAM Specification	jedec.org/standards-documents/docs/jesd79-4.pdf
PCI Express PCI Express Base Specification Rev. 2.0 and 3.0	pcsig.com/specifications/pciexpress
PMBus Power System Management Protocol Specification, v1.2	pmbus.info/specs.html
SAS Serial Attached SCSI, v1.1	t10.org
SATA Serial ATA Rev. 2.6; SATA II, SATA 1.0a Extensions, Rev. 1.2	sata-io.org
SMBIOS System Management BIOS Reference Specification, v2.7	dmtf.org/standards/smbios
TPM Trusted Platform Module Specification, v1.2 and v2.0	trustedcomputinggroup.org
UEFI Unified Extensible Firmware Interface Specification, v2.1	uefi.org/specifications
USB Universal Serial Bus Specification, Rev. 2.0	usb.org/developers/docs

Appendix C Additional resources

Table 32. Additional resources

Resource	Description of contents	Location
Installation and Service Manual	<p>This manual, available in PDF format, provides the following information:</p> <ul style="list-style-type: none"> • Chassis features • System Setup program • System messages • System codes and indicators • System BIOS • Remove and replace procedures • Troubleshooting • Diagnostics • Jumpers and connectors 	Dell.com/Support/Manuals
Getting Started Guide	<p>This guide ships with the system, and is also available in PDF format. This guide provides the following information:</p> <ul style="list-style-type: none"> • Initial setup steps • Key system features • Technical specifications 	Dell.com/Support/Manuals
Rack Installation Instructions	This document ships with the rack kits, and provides instructions for installing a server in a rack.	Dell.com/Support/Manuals
Information Update	This document ships with the system, is also available in PDF format online, and provides information on system updates.	Dell.com/Support/Manuals
System Information Label	The system information label documents the system board layout and system jumper settings. Text is minimized due to space limitations and translation considerations. The label size is standardized across platforms.	Inside the system chassis cover
Quick Resource Locator (QRL)	This code on the chassis can be scanned by a phone application to access additional information and resources for the server, including videos, reference materials, service tag information, and Dell EMC contact information.	Inside the system chassis cover
Energy Smart Solution Advisor (ESSA)	The Dell EMC online ESSA enables easier and more meaningful estimates to help you determine the most efficient configuration possible. Use ESSA to calculate the power consumption of your hardware, power infrastructure, and storage.	Dell.com/calc

Appendix D. Dell Technologies Services

Dell Technologies Services include a wide, customizable range of service choices to simplify the assessment, design, implementation, management and maintenance of IT environments and to help you transition from platform to platform. Depending on your current business requirements and the level of service they want, we provide factory, on-site, remote, modular and specialized services that fit your needs and budget. We'll help with a little or a lot - your choice - and provide access to our global resources.

For more information, see DellEMC.com/Services

Topics:

- [ProDeploy Enterprise Suite and Residency Services](#)
- [Remote Consulting Services](#)
- [Data Migration Service](#)
- [ProSupport Enterprise Suite](#)
- [ProSupport Plus](#)
- [ProSupport](#)
- [ProSupport One for Data Center](#)
- [Support Technologies](#)
- [Education Services](#)
- [Dell Technologies Consulting Services](#)
- [Managed Services](#)

ProDeploy Enterprise Suite and Residency Services

ProDeploy Enterprise Suite gets your server out of the box and into optimized production - fast. Our elite deployment engineers with broad and deep experience utilizing best-in-class processes along with our established global scale can help you around the clock and around the globe. From simple to the most complex server installations and software integration, we take the guess work and risk out of deploying your new server technology. Who's better suited to implement the latest Dell EMC servers than the Dell EMC elite deployment engineers who do it every day?

		Basic Deployment	ProDeploy	ProDeploy Plus
Pre-deployment	Single point of contact for project management		•	In-region
	Site readiness review		•	•
	Implementation planning		•	•
	Technology Service Manager (TSM) engagement for ProSupport Plus entitled devices			•
Deployment	Deployment service hours	Business hours	24x7	24x7
	Onsite hardware installation*	•	•	•
	Packaging materials disposal	•	•	•
	Install and configure system software		•	Onsite
Post-deployment	Project documentation with knowledge transfer		•	•
	Deployment verification		•	•
	Configuration data transfer to Dell EMC technical support		•	•
	30-days of post-deployment configuration assistance			•
	Training credits for Dell EMC Education Services			•

Figure 11. ProDeploy Enterprise Suite capabilities

NOTE: Hardware installation not applicable on selected software products.

ProDeploy Plus

From beginning to end, ProDeploy Plus provides the skill and scale needed to successfully execute demanding deployments in today's complex IT environments. Certified Dell EMC experts start with extensive environmental assessments and detailed migration planning and recommendations. Software installation includes set up of most versions of Dell EMC SupportAssist and OpenManage system management utilities. Post-deployment configuration assistance, testing, and product orientation help you rest easy knowing your systems have been deployed and integrated by the best.

ProDeploy

ProDeploy provides full service installation and configuration of both server hardware and system software by certified deployment engineers including set up of leading operating systems and hypervisors as well as most versions of Dell EMC SupportAssist and OpenManage system management utilities. To prepare for the deployment, we conduct a site readiness review and implementation planning. System testing, validation and full project documentation with knowledge transfer complete the process. We focus on getting you up and running so you can focus on your business and prepare for whatever comes next.

Basic Deployment

Basic Deployment delivers worry-free professional installation by experienced technicians who know Dell EMC servers inside and out.

Server Configuration Services

With Rack Integration and other Server Configuration Services, you save time by receiving your systems racked, cabled, tested, and ready to integrate into the data center. Dell EMC staff pre-configure RAID, BIOS and iDRAC settings, install system images, and even install 3rd party hardware and software.

For more information, see [Server Configuration Services](#).

Residency Services

Residency helps customers transition to new capabilities quickly through on-site or remote Dell EMC experts whose priorities and time you control. Residency experts can provide post implementation management and knowledge transfer related to a new technology acquisition or day-to-day operational management of the IT infrastructure.

Remote Consulting Services

When you are in the final stages of your PowerEdge server implementation, you can rely on Dell EMC Remote Consulting and our certified technical experts to help you optimize your configuration with best practices for your software, virtualization, server, storage, networking, and systems management.

Data Migration Service

Protect your business and data with our single point of contact to manage your data migration project. Your project manager will work with our experienced team of experts to create a plan using industry-leading tools and proven processes based on global best practices to migrate your existing files and data, so your business system get up and running quickly and smoothly.

ProSupport Enterprise Suite

With Dell EMC ProSupport Services, we can help you keep your operation running smoothly, so you can focus on running your business. We will help you maintain peak performance and availability of your most essential workloads. Dell EMC ProSupport is a suite of support services that enable you to build the solution that is right for your organization. Choose support models based on how you use technology and where you want to allocate resources. From the desktop to the data center, address everyday IT challenges, such as unplanned downtime, mission-critical needs, data and asset protection, support planning, resource allocation, software application management and more. Optimize your IT resources by choosing the right support model.

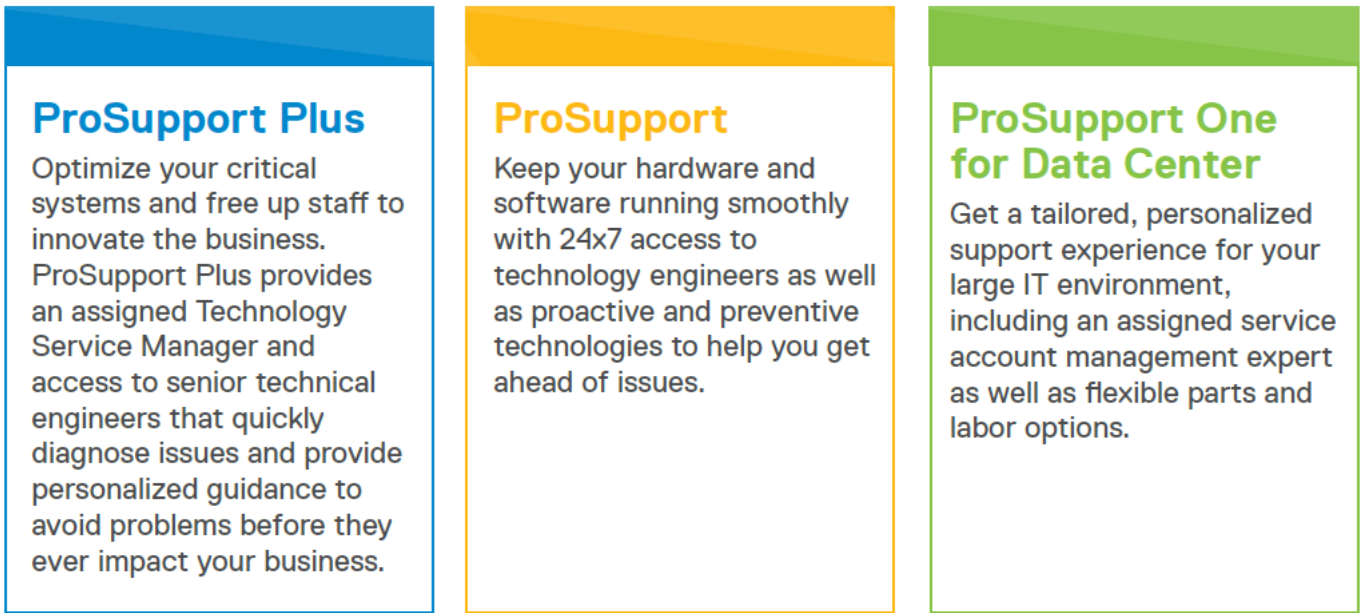

Figure 12. ProSupport Enterprise Suite

ProSupport Plus

When you purchase your PowerEdge server, we recommend ProSupport Plus, our proactive and preventative support for your business-critical systems. ProSupport Plus provides you with all the benefits of ProSupport, plus the following:

- An assigned Technology Service Manager who knows your business and your environment
- Access to senior ProSupport engineers for faster issue resolution
- Personalized, preventive recommendations based on analysis of support trends and best practices from across the Dell EMC customer base to reduce support issues and improve performance
- Predictive analysis for issue prevention and optimization enabled by SupportAssist
- Proactive monitoring, issue detection, notification and automated case creation for accelerated issue resolution enabled by SupportAssist
- On-demand reporting and analytics-based recommendations enabled by SupportAssist and TechDirect

ProSupport

Our ProSupport service offers highly trained experts around the clock and around the globe to address your IT needs. We help minimize disruptions and maximize availability of PowerEdge server workloads with:

- 24x7x365 access to certified hardware and software experts
- Hypervisor and OS support
- Consistent level of support available for Dell EMC hardware, software and solutions
- Onsite parts and labor response options including next business day or four-hour mission critical
- A single point of accountability for any eligible 3rd party software

Enterprise Support Services Feature Comparison

	Basic	ProSupport	ProSupport Plus
Remote technical support	9x5	24x7	24x7
Covered products	Hardware	Hardware Software	Hardware Software
Onsite hardware support	Next business day	Next business day or 4hr mission critical	Next business day or 4 hr mission critical
Automated issue detection & proactive case creation		●	●
Self-service case initiation and management		●	●
Access to software updates		●	●
Priority access to specialized support experts			●
3 rd party software support			●
Assigned Technology Service Manager			●
Personalized assessments and recommendations			●
Semiannual systems maintenance			●

Availability and terms of Dell Technologies services vary by region and by product. For more information, please view our Service Descriptions available on Dell.com



Figure 13. Dell EMC Enterprise Support model

ProSupport One for Data Center

ProSupport One for Data Center offers flexible site-wide support for large and distributed data centers with more than 1,000 assets. This offering is built on standard ProSupport components that leverage our global scale but are tailored to your company's needs. While not for everyone, it offers a truly unique solution for Dell EMC's largest customers with the most complex environments.

- Team of assigned Technology Services Managers with remote, on-site options
- Assigned ProSupport One technical and field engineers who are trained on your environment and configurations
- On-demand reporting and analytics-based recommendations enabled by SupportAssist and TechDirect
- Flexible on-site support and parts options that fit your operational model
- A tailored support plan and training for your operations staff

Support Technologies

Powering your support experience with predictive, data-driven technologies.

SupportAssist

The best time to solve a problem is before it happens. The automated proactive and predictive technology SupportAssist* helps reduce steps and time to resolution, often detecting issues before they become a crisis. Benefits include:

- Value - SupportAssist is available to all customer at no additional charge
- Improve productivity - replace manual, high-effort routines with automated support
- Accelerate time to resolution - receive issue alerts, automatic case creation and proactive contact from Dell EMC experts
- Gain insight and control - optimize enterprise devices with on-demand ProSupport Plus reporting in TechDirect and get predictive issue detection before the problem starts

SupportAssist is included with all support plans but features vary based on service level agreement.

	Basic Hardware Warranty	ProSupport	ProSupport Plus
Automated issue detection and system state information collection	•	•	•
Proactive, automated case creation and notification		•	•
Predictive issue detection for failure prevention			•
Recommendation reporting available on-demand in TechDirect			•

Figure 14. SupportAssist model

Get started at Dell.com/SupportAssist

TechDirect

Boost IT team productivity when supporting Dell EMC systems. With over 1.4 million self-dispatches processed each year, TechDirect has proven its effectiveness as a support tool. You can:

- Self-dispatch replacement parts
- Request technical support
- Integrate APIs into your help desk

Or, access all your Dell EMC certification and authorization needs. Train your staff on Dell EMC products as TechDirect allows you to:

- Download study guides
- Schedule certification and authorization exams
- View transcripts of completed courses and exams

Register at techdirect.dell

Education Services

Build the IT skills required to influence the transformational outcomes of the business. Enable talent and empower teams with the right skills to lead and execute transformational strategy that drives competitive advantage. Leverage the training and certification required for real transformation.

Dell Technologies Education Services offers the PowerEdge server training and certifications designed to help you achieve more from your hardware investment. The curriculum delivers the information and the practical, hands-on skills that you and your team need to confidently install, configure, manage, and troubleshoot your Dell EMC servers. To learn more or register for a class today, visit LearnDell.com/Server.

Dell Technologies Consulting Services

Our expert consultants help you transform faster and quickly achieve business outcomes for high value workloads being considered for the Dell EMC PowerEdge.

From strategy to full-scale implementation, Dell Technologies Consulting can help you determine how to execute your IT, workforce or application transformation.

We use prescriptive approaches and proven methodologies, combined with Dell Technologies' portfolio and partner ecosystem, to help you achieve real business outcomes. From multi-cloud, applications, DevOps and infrastructure transformations, to business resiliency, data center modernization, analytics, workforce collaboration and user experiences - we're here to help.

Managed Services

Reduce the cost, complexity and risk of managing IT. Focus your resources on digital innovation and transformation while our experts help optimize your IT operations and investment with managed services backed by guaranteed service levels.