



USER MANUAL

EZ-LIFT SERIES INTERACTIVE WALL MOUNTS



EZ1/ML145

Consists of:

EZ1/MB16/152 Mount Body
EZ1/MA1 VESA Bracket

Displays up to **79-140 lbs (36-64 kg)**

VESA Mounting: 200 x 200 – 800 x 670

EZ1/ML209

Consists of:

EZ1/MB16/209 Mount Body
EZ1/MA1 VESA Bracket

Displays up to **134-197 lbs (61-90 kg)**

VESA Mounting: 200 x 200 - 800 x 670

EZ1/ML095

Consists of:

EZ1/MB16/095 Mount Body
EZ1/MA5 VESA Bracket

Displays up to **41-85 lbs (18-38 kg)**

VESA Mounting: 200 x 100 - 800 x 440

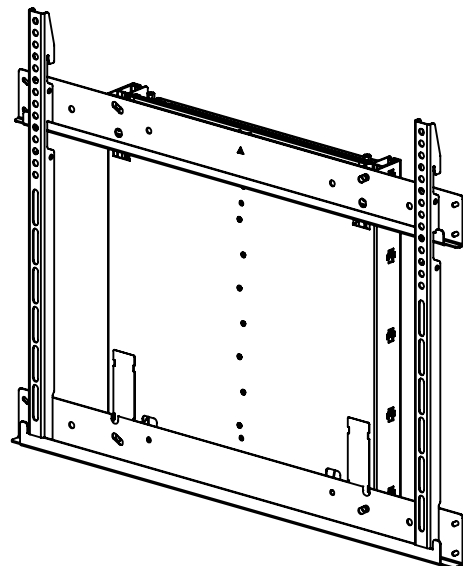
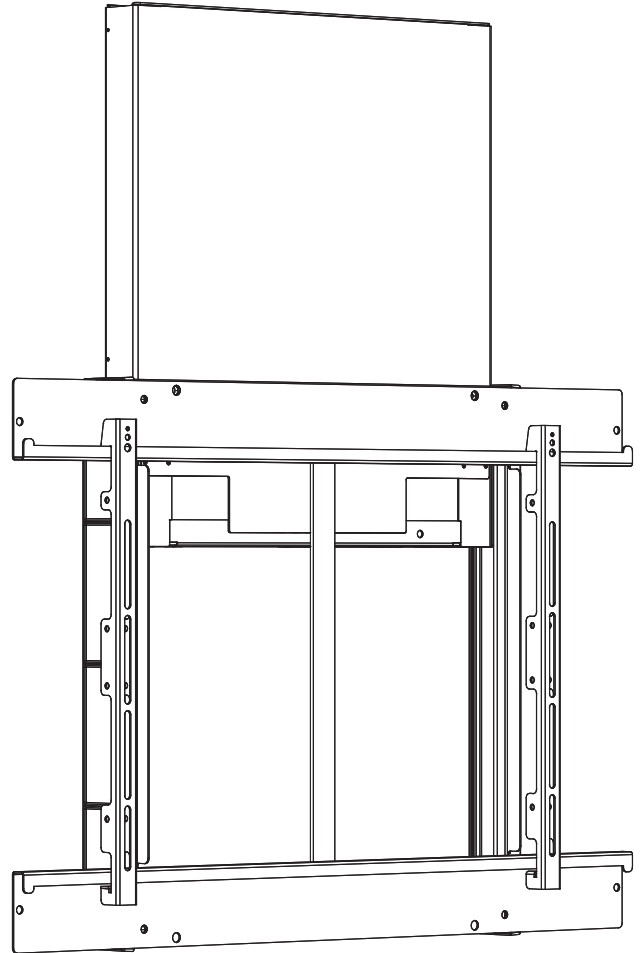

PARTS - EZ1/ML145 / EZ1/ML209 / EZ1/ML095

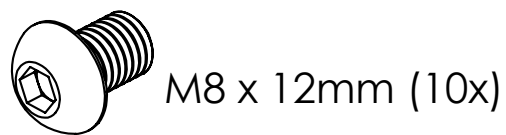
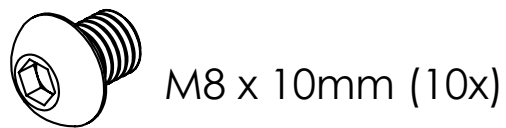
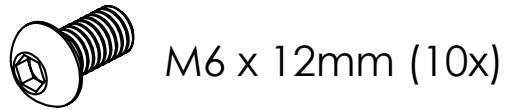
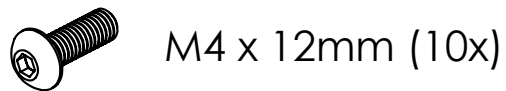
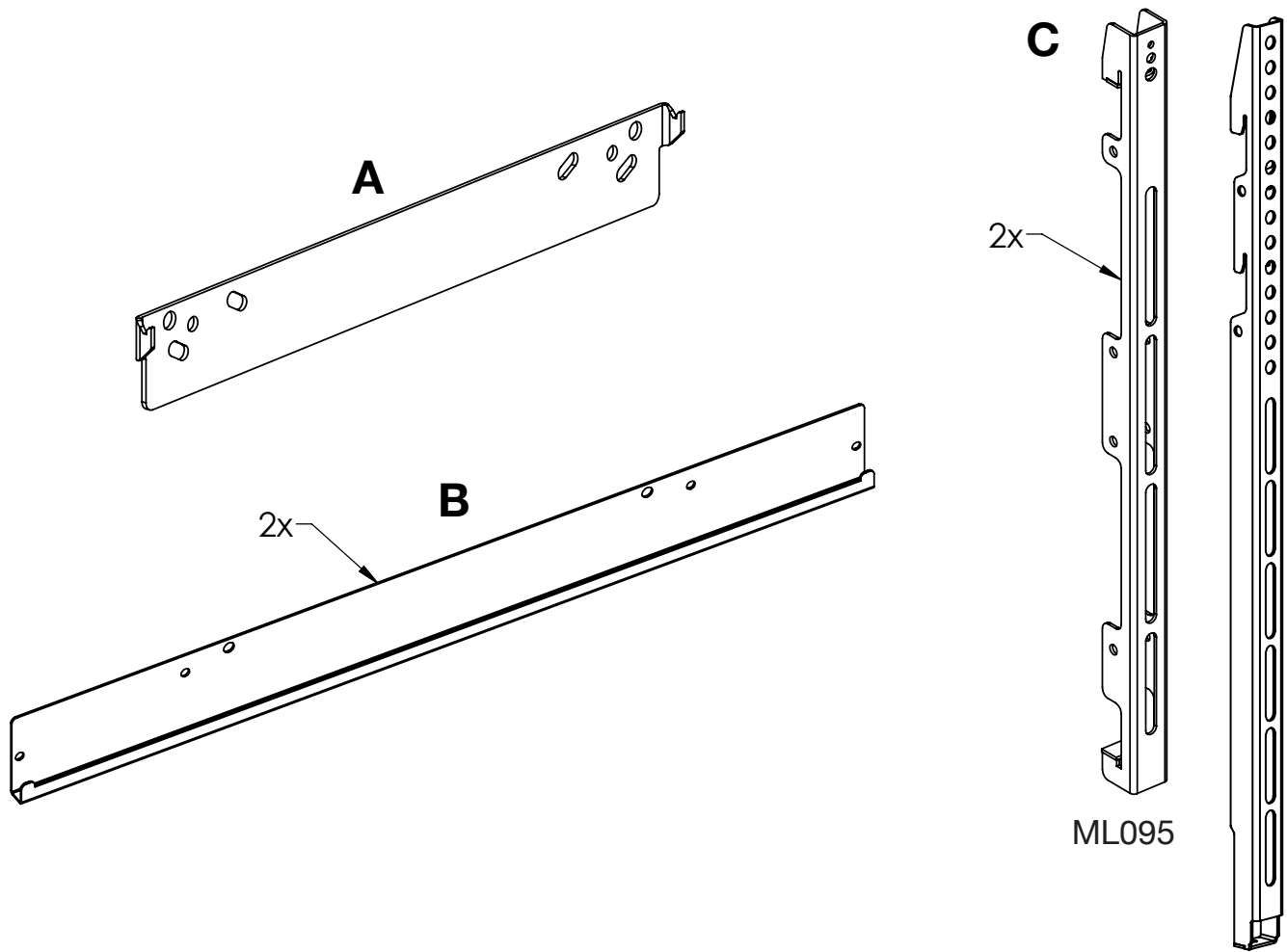

How to use this manual

- 1 Read manual carefully before you install the mount
- 2 Carry out the actions fully and in the given sequence
- 3 The mount guarantee is voided if the product is not correctly installed or modified in any way

Warning symbols used

- A Sharp edges
- B Wear glove
- C Physical load
- D Two people required
- E Entanglement hazard
- F Warning: Can cause personal injury or equipment damage



A



B



C



D



E



F

Intended use

The EZ-Lift Mount is a system that compensates the mass of vertically moving displays to ease vertical movement of the display.

General warning

The display may only be attached to or removed from the EZ-Lift when the EZ-Lift is in closed position. The EZ-Lift is under strong spring force. Only operate the EZ-Lift with an adequately balanced display attached to the display frame. Do not remove any parts of the EZ-Lift. Only the finishing cover can be removed.

Mounting fasteners

Mounting fasteners are not included with the product. Obtain advice from a specialist.

Setting the springs

Adjust only the outer springs:

- Adjust the height of the outer springs equally
- Make sure that the height of the display is balanced
- Increase the spring tension as much as possible
- Make sure that the display does not move up

Never adjust the inner springs

Disposal of the EZ-Lift

Springs should be unattached before disposal of the EZ-Lift. Sort the EZ-Lift, the accessories and the packaging for the environmentally friendly recycling.

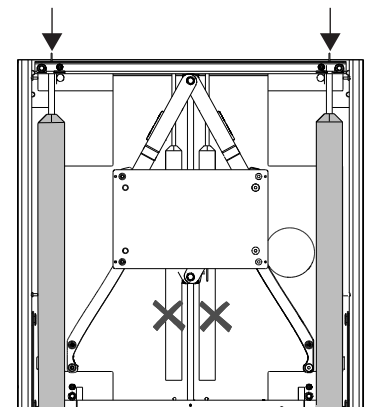

Installation of EZ1/MB16/152 Mount Body

Prepare Mounting Site

The EZ-Lift was designed to be installed on a 16" on center 2" x 4" wood stud, or metal studs, using high-quality hollow wall anchor installed in the center of the stud or a solid concrete wall.



WARNING: INSTALLING THE MOUNT IN UNDERRATED OR DAMAGED CONCRETE CAN LEAD TO SERIOUS INJURY OR DAMAGE TO PRODUCT! When installing into concrete only install the mount in a solid concrete wall made of 2500 PSI (17.3 MPa) or stronger concrete. Never install the mount into cracked, chipped or flaking concrete.



WARNING: IMPROPER INSTALLATION CAN LEAD TO MOUNT FALLING CAUSING SERIOUS PERSONAL INJURY OR DAMAGE TO EQUIPMENT! It is the installers responsibility to make sure the structure to which the EZ-Lift is being installed is capable of supporting three times the combined weight of the EZ-Lift and all attached equipment is not to exceed the following weight capacities:

EZ1/MB16/152: 90-152lbs / 40-69kg

Mounting EZ-LIFT Mount Body to Wall

Unpack the EZ-Lift and remove the plastic cover and two foam blocks.

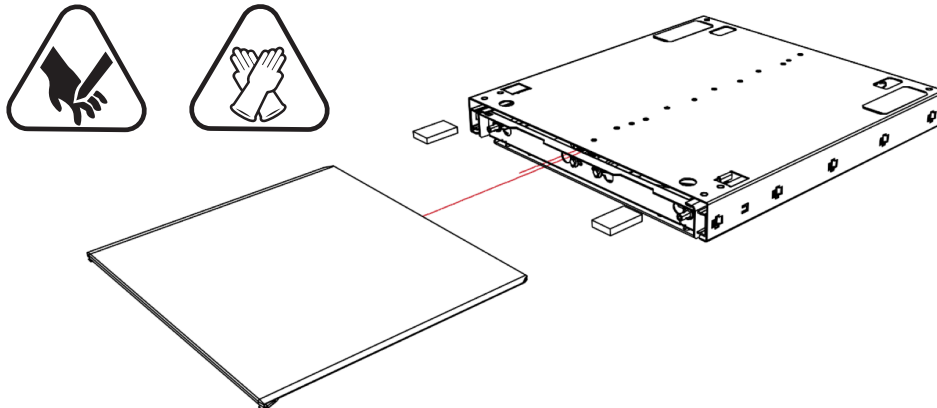

Locating your mount

WOOD CONSTRUCTION: locate two framing studs (minimum of 16" (405 mm) apart) at the desired location using a stud finder device.

MASONRY:

a minimum width of 16" (405 mm) is required between fasteners.

Determine mounting height

See below for recommended mounting height for 55" Display. Other displays can be calculated by adding half the height difference to the top and half the height difference to the bottom of the example shown

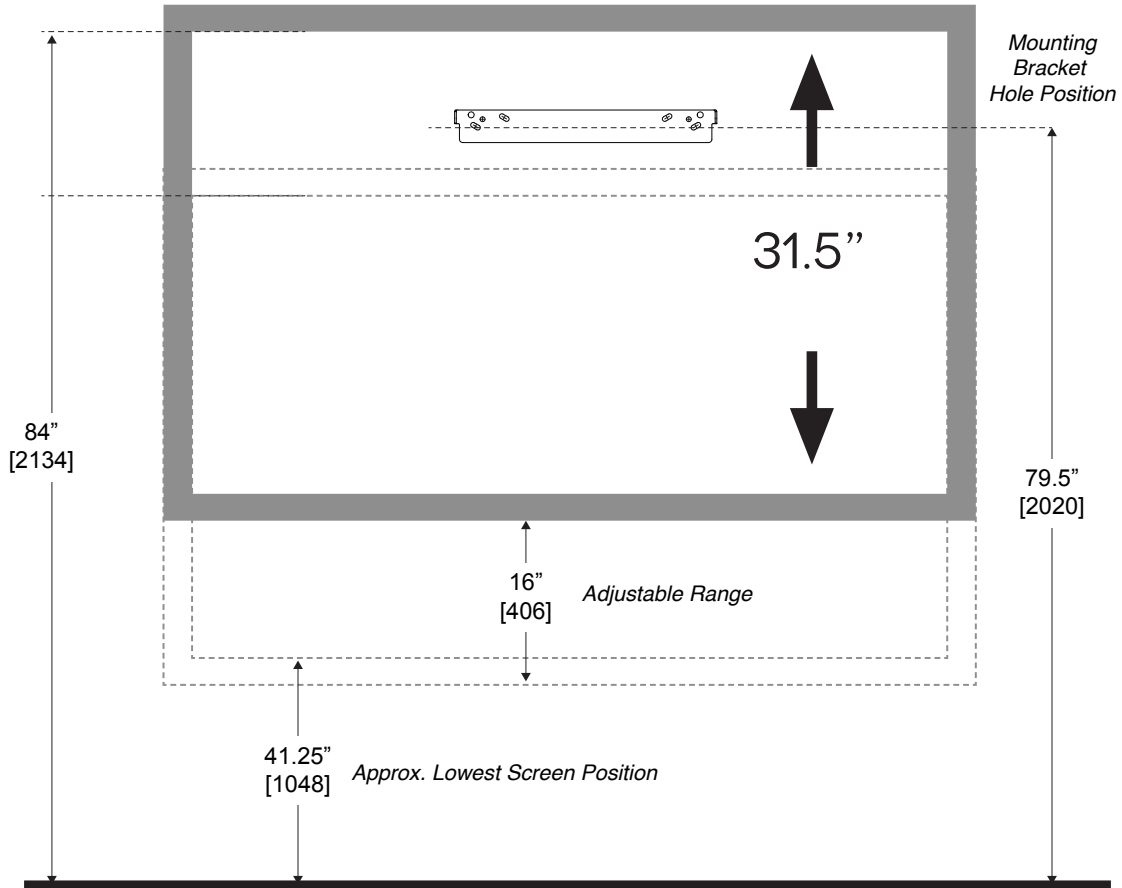

Mounting bracket level to wall

Unpack the EZ-Lift Take the wall bracket out (A) of the box. Note the slotted/slanted holes for level wall mounting.

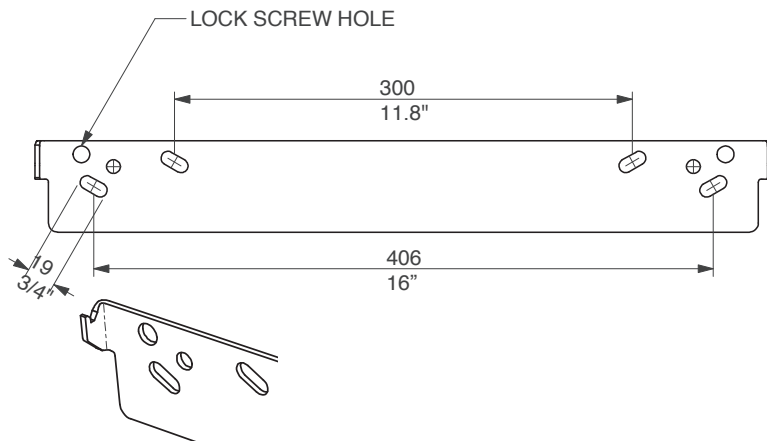

Make sure screws are unlocked

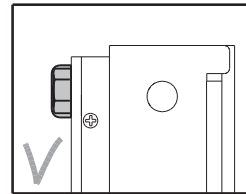
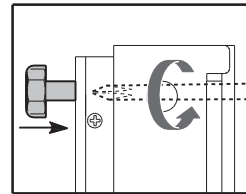
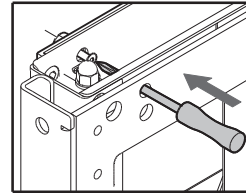
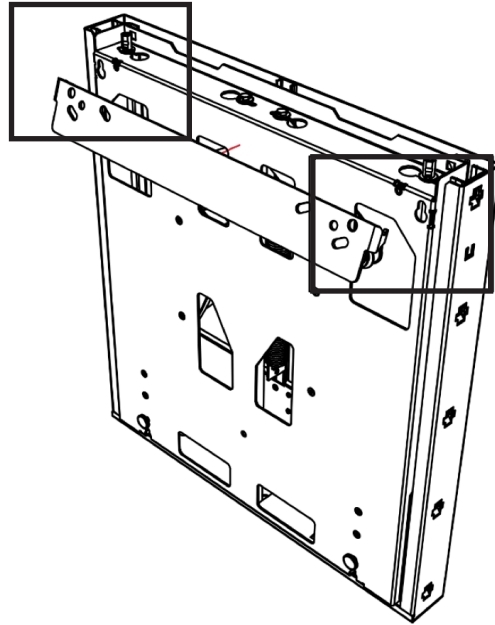

Lift the mount onto bracket

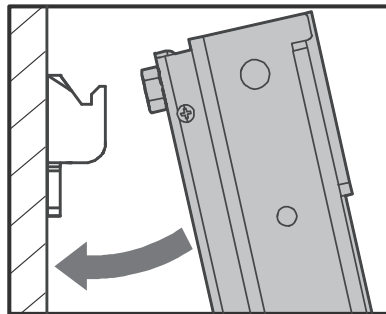
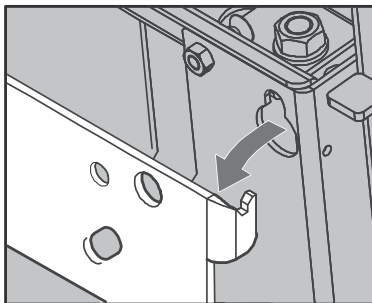

Lock mount with screws

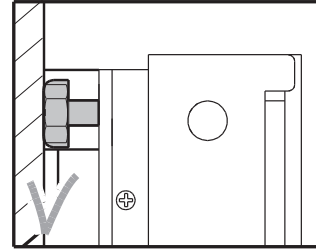
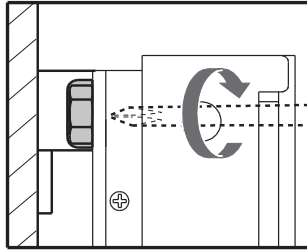
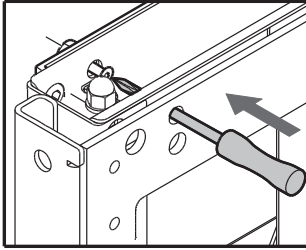

Level vertically with feet at the bottom

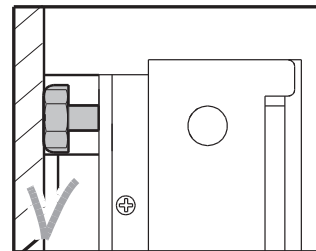
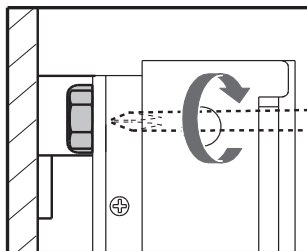
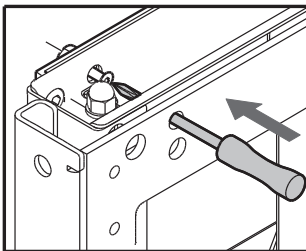
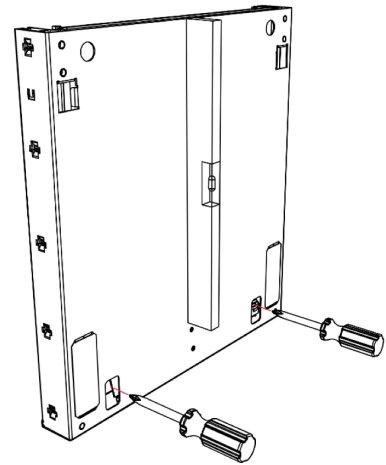
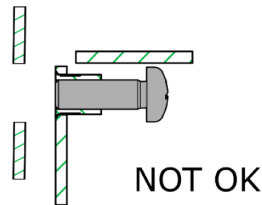
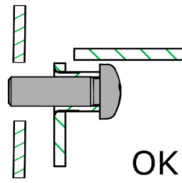
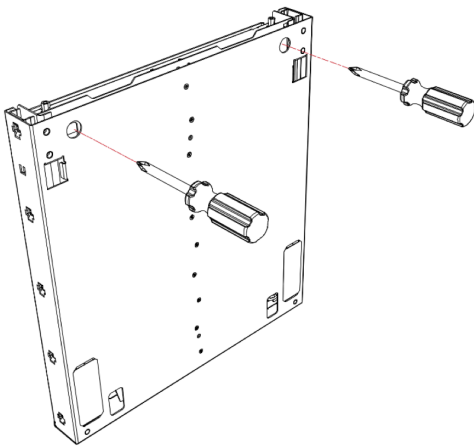

Insert plastic cover

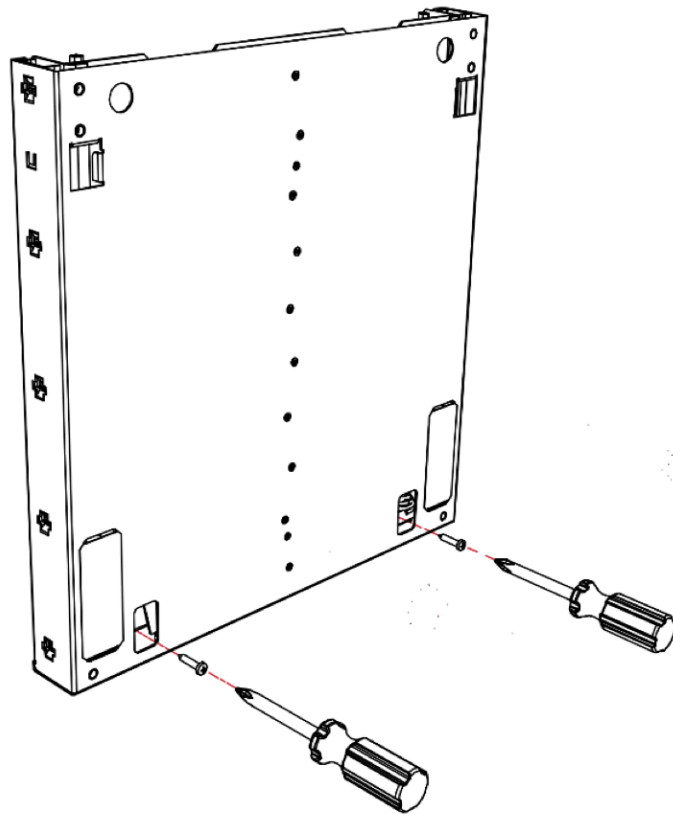
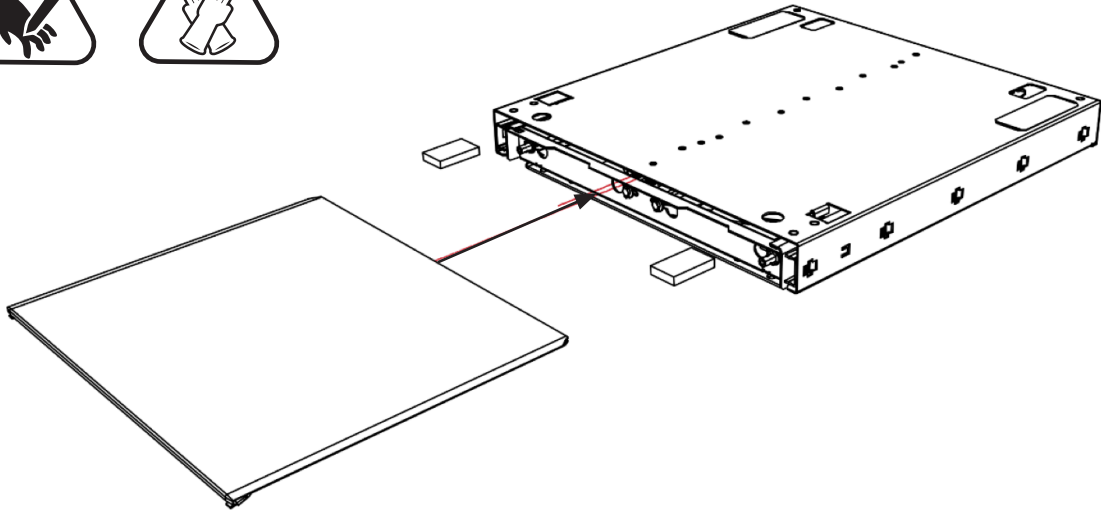

Attach brackets to mount and display

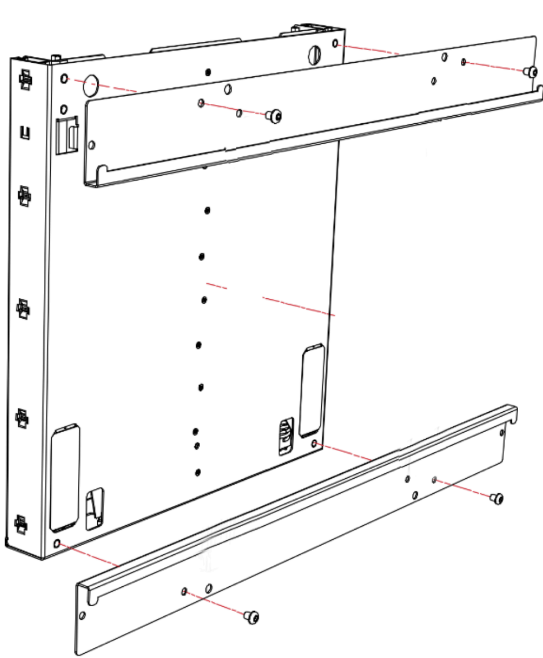

OR

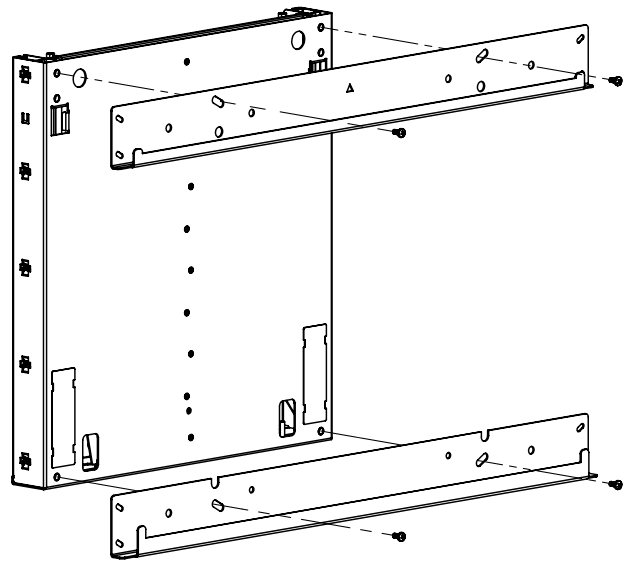

M4 x 12mm (10x) or
M6 x 12mm (10x) or
M8 x 12mm (10x)

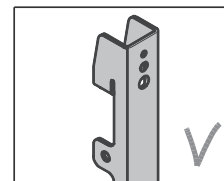
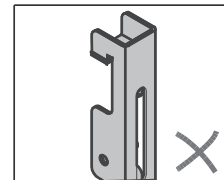
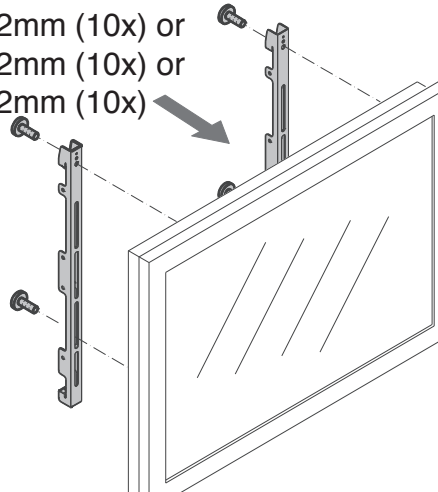

Hang display onto horizontal bracket and level

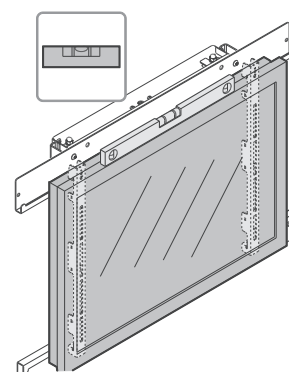
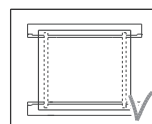
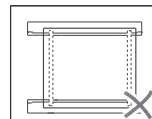
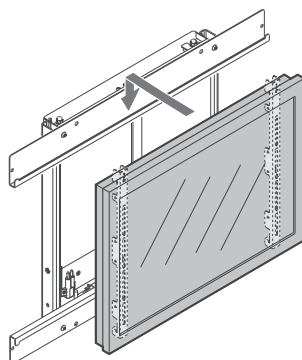

Lock display with safety lock screws from the bottom

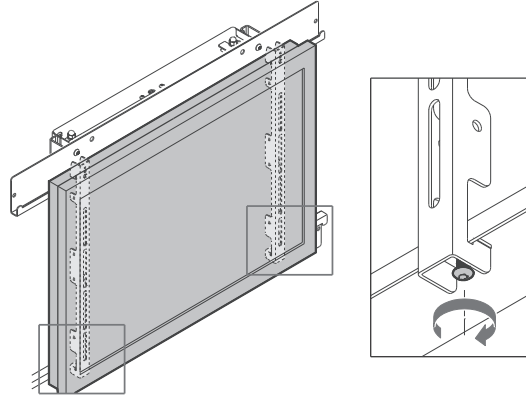

Set balance

Balancing: Springs are always fully tightened for safety. Use a drill driver and 1/2" (13 mm) socket, rotate counter clockwise (loosen) evenly. Do three seconds left and three seconds right until the mount is evenly balanced to support display weightlessly.

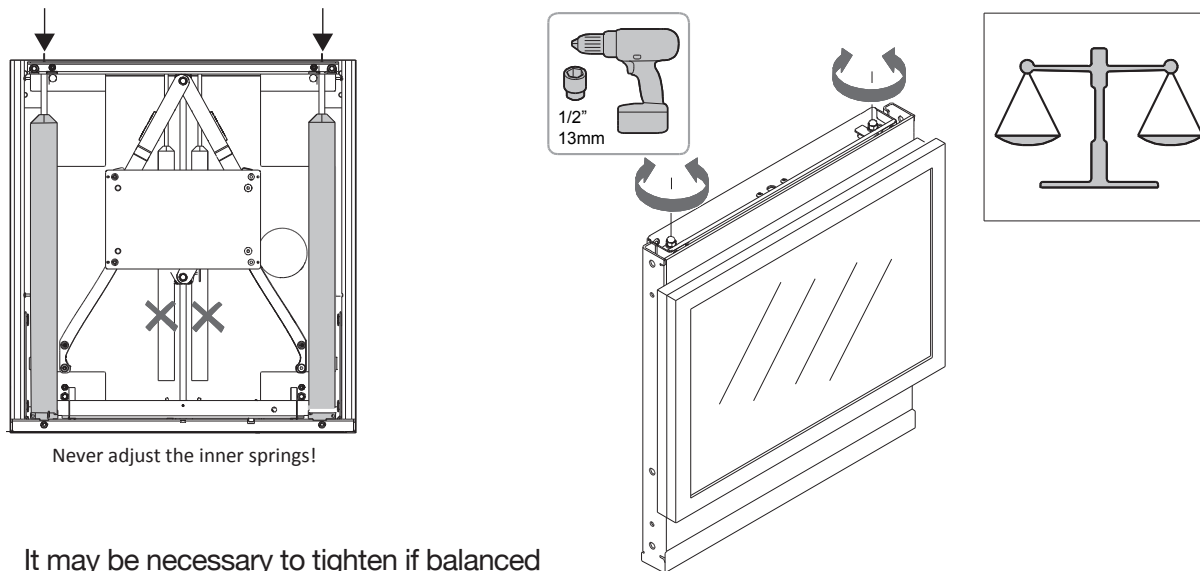

Never adjust the inner springs!

It may be necessary to tighten if balanced point is exceeded.



SALAMANDER WARRANTY LIMITED WARRANTY FOR COMMERCIAL VIDEO DISPLAY STANDS AND MOUNTS

Salamander warrants against manufacturing defects for two (2) years from the date of purchase. Salamander will repair or replace, at our option, any product defective in materials or craftsmanship. Batteries are not covered by the warranty.

Full warranty including limitations and warranty claim information may be found at www.salamandercommercial.com

Subject to printing errors and technical amendments.