



Hewlett Packard
Enterprise

HPE ProLiant DL380 Gen10 Plus Server User Guide

Part Number: 30-5179FE22-001

Published: May 2021

Edition: 1

HPE ProLiant DL380 Gen10 Plus Server User Guide

Abstract

This document is for the person who installs, administers, and troubleshoots servers and storage systems. Hewlett Packard Enterprise assumes you are qualified in the servicing of computer equipment and trained in recognizing hazards in products with hazardous energy levels.

Part Number: 30-5179FE22-001

Published: May 2021

Edition: 1

© Copyright 2021 Hewlett Packard Enterprise Development LP

Notices

The information contained herein is subject to change without notice. The only warranties for Hewlett Packard Enterprise products and services are set forth in the express warranty statements accompanying such products and services. Nothing herein should be construed as constituting an additional warranty. Hewlett Packard Enterprise shall not be liable for technical or editorial errors or omissions contained herein.

Confidential computer software. Valid license from Hewlett Packard Enterprise required for possession, use, or copying. Consistent with FAR 12.211 and 12.212, Commercial Computer Software, Computer Software Documentation, and Technical Data for Commercial Items are licensed to the U.S. Government under vendor's standard commercial license.

Links to third-party websites take you outside the Hewlett Packard Enterprise website. Hewlett Packard Enterprise has no control over and is not responsible for information outside the Hewlett Packard Enterprise website.

Acknowledgments

Intel[®], Itanium[®], Optane[™], Pentium[®], Xeon[®], Intel Inside[®], and the Intel Inside logo are trademarks of Intel Corporation in the U.S. and other countries.

Microsoft[®], Windows[®], and Windows Server[®] are either registered trademarks or trademarks of Microsoft Corporation in the United States and/or other countries.

Linux[®] is the registered trademark of Linus Torvalds in the U.S. and other countries.

VMware ESXi[™] and VMware vSphere[®] are registered trademarks or trademarks of VMware, Inc. in the United States and/or other jurisdictions.

Red Hat[®] Enterprise Linux[®] are registered trademarks of Red Hat, Inc. in the United States and other countries.

microSD[®] is a trademark or a registered trademark of SD-3D in the United States, other countries of both.

All third-party marks are property of their respective owners.

Table of contents

1 Component identification

- 1.1 Front panel components
- 1.2 Front panel LEDs and buttons
 - 1.2.1 UID button functionality
 - 1.2.2 Front panel LED power fault codes
 - 1.2.3 Systems Insight Display LEDs
 - 1.2.4 Systems Insight Display combined LED descriptions
- 1.3 Rear panel components
- 1.4 Rear panel LEDs
- 1.5 System board components
 - 1.5.1 Heatsink and socket components
 - 1.5.2 DIMM label identification
 - 1.5.3 Intel Optane persistent memory 200 series for HPE label identification
 - 1.5.4 DIMM slot locations
 - 1.5.5 System maintenance switch descriptions
- 1.6 Drive box identification
- 1.7 Drive numbering
- 1.8 HPE Basic Drive LED definitions
- 1.9 Fan bay numbering
- 1.10 DSC-25 2-port SFP28 card ports and LEDs
- 1.11 HPE NS204i-p NVMe OS Boot Device components
- 1.12 HPE NS204i-p NVMe OS Boot Device LED definitions

2 Operations

- 2.1 Power up the server
- 2.2 Power down the server
- 2.3 Extending the server from the rack
- 2.4 Secure cables using the cable management arm
- 2.5 Removing the server from the rack
- 2.6 Remove the access panel
- 2.7 Install the access panel
- 2.8 Removing the fan cage
- 2.9 Installing the fan cage
- 2.10 Removing the air baffle or midplane drive cage
- 2.11 Installing the air baffle
- 2.12 Removing a riser cage
- 2.13 Removing a riser slot blank
- 2.14 Removing the hard drive blank
- 2.15 Releasing the cable management arm
- 2.16 Accessing the Systems Insight Display

3 Setup

- 3.1 Optional services
- 3.2 Set up the server

- 3.2.1 Operational requirements
 - 3.2.1.1 Space and airflow requirements
 - 3.2.1.2 Temperature requirements
 - 3.2.1.3 Power requirements
 - 3.2.1.4 Electrical grounding requirements
 - 3.2.1.5 Connecting a DC power cable to a DC power source
- 3.2.2 Server warnings and cautions
- 3.2.3 Rack warnings
- 3.2.4 Electrostatic discharge
- 3.2.5 Server box contents
- 3.2.6 Installing hardware options
- 3.2.7 POST screen options
- 3.2.8 Installing or deploying an operating system
- 3.2.9 Registering the server

4 Hardware options installation

- 4.1 Product QuickSpecs
- 4.2 Introduction
- 4.3 Installing a fan filter into the security bezel
- 4.4 Installing the bezel and bezel lock
- 4.5 Power supply options
 - 4.5.1 Hot-plug power supply calculations
 - 4.5.2 Installing a redundant hot-plug power supply
 - 4.5.3 Installing the HPE 800 W Flex Slot -48 VDC hot-plug power supply
 - 4.5.4 Installing the HPE 1600 W Flex Slot -48 VDC hot-plug power supply
 - 4.5.5 Connecting a DC power cable to a DC power source
- 4.6 Energy pack options
 - 4.6.1 HPE Smart Storage Battery
 - 4.6.2 HPE Smart Storage Hybrid Capacitor
 - 4.6.3 Minimum firmware versions
 - 4.6.4 Installing an energy pack
- 4.7 Memory options
 - 4.7.1 Memory population information
 - 4.7.2 DIMM-processor compatibility
 - 4.7.3 HPE SmartMemory speed information
 - 4.7.4 Installing a DIMM blank
 - 4.7.5 Installing a DIMM
 - 4.7.6 Intel Optane persistent memory 200 series for HPE
 - 4.7.6.1 Persistent memory module-processor compatibility
 - 4.7.6.2 Persistent memory module population information
 - 4.7.6.3 System requirements for persistent memory module support
 - 4.7.6.4 Installing persistent memory modules
 - 4.7.6.5 Configuring the server for Intel Optane persistent memory 200 series for HPE
- 4.8 Fan options
 - 4.8.1 Installing high-performance fans

4.9 Drive options

4.9.1 Drive guidelines

4.9.2 Installing a hot-plug SAS, SATA or NVMe drive

4.9.3 Installing an M.2 drive

4.10 Installing a Universal Media Bay

4.11 Storage controller options

4.11.1 Installing a storage controller

4.12 Riser and riser cage options

4.12.1 Installing primary and secondary risers

4.12.2 Installing tertiary risers

4.12.3 Installing a secondary riser cage

4.12.4 Installing a tertiary riser cage

4.13 Expansion slots

4.13.1 Supported PCIe form factors

4.13.2 Installing expansion boards

4.13.3 Accelerator options

4.13.3.1 Installing an accelerator or GPU

4.14 Drive cage options

4.14.1 Installing a front 8NVMe drive cage

4.14.2 Installing a front 8 SFF SAS/SATA drive cage in box 1

4.14.3 Installing a front 8 SFF SAS/SATA drive cage in box 2

4.14.4 Installing a front/tertiary 2 SFF NVMe/SAS/SATA stackable drive cage

4.14.5 Installing a midplane drive cage

4.14.6 Installing a rear 2 SFF SAS/SATA drive cage in the primary or secondary riser

4.14.7 Installing a rear 2 SFF SAS/SATA drive cage over the power supplies

4.14.8 Installing a rear 2LFF SAS/SATA drive cage in the primary or secondary riser

4.15 Processor and heatsink options

4.15.1 Installing a processor heatsink assembly

4.15.2 Installing a high performance heatsink

4.16 Installing the chassis intrusion detection switch

4.17 Installing an OCP 3.0 adapter card

4.18 Installing the Pensando DSP DSC-25 2p SFP28 card

4.19 Installing the HPE NS204i-p NVMe OS Boot Device option

4.20 Installing a rear serial port interface

4.21 Installing the Systems Insight Display

4.22 HPE Trusted Platform Module 2.0 Gen10 Plus option

4.22.1 Overview

4.22.2 HPE Trusted Platform Module 2.0 guidelines

4.22.3 Installing and enabling the HPE TPM 2.0 Gen10 Plus option

4.22.3.1 Installing the Trusted Platform Module board

4.22.3.1.1 Preparing the server for installation

4.22.3.1.2 Installing the TPM board and cover

4.22.3.1.3 Preparing the server for operation

4.22.3.2 Enabling the Trusted Platform Module

4.22.3.2.1 Enabling the Trusted Platform Module as TPM 2.0

4.22.3.2.2 Enabling the Trusted Platform Module as TPM 1.2

4.22.3.3 Retaining the BitLocker recovery key/password

5 Cabling

5.1 Cabling guidelines

5.2 Power cabling

5.2.1 Cable routing: Front 8SFF power cabling

5.2.2 Cable routing: Front 12LFF power cabling

5.2.3 Cable routing: Midplane power cabling

5.2.4 Cable routing: Front 2SFF side-by-side power cabling

5.2.5 Cable routing: Rear 2SFF power cabling

5.3 Cabling diagrams

5.3.1 Cable routing: 2NVMe box 6 to AROC NVMe adapter

5.3.2 Cable routing: 6NVMe box 3 to 3-port primary riser

5.3.3 Cable routing: 6NVMe box 3 to 3-port primary riser

5.3.4 Cable routing: 8NVMe balanced box 2 to system board

5.3.5 Cable routing: 8NVMe P2 box 1 to system board/secondary riser

5.3.6 Cable routing: 8NVMe P1 box 3 to system board/primary riser

5.3.7 Cable routing: 12NVMe BAL P1 box 2+3 to system board/primary riser/OCV NVMe adapter/Type-a controller

5.3.8 Cable routing: 12NVMe BAL P2 box 1+2 to system board/4-port NVMe secondary riser

5.3.9 Cable routing: 12NVMe DIFF P1 box 2+3 to system board/4-port NVMe primary riser

5.3.10 Cable routing: 12NVMe DIFF P1 box 1+2 to system board/4-port NVMe secondary riser

5.3.11 Cable routing: 24NVMe Balanced

5.3.12 Cable routing: 24NVMe Differential

5.3.13 Cable routing: 8NVMe box 3 to 4-port primary riser

5.3.14 Cable routing: 8NVMe box 1 to 4-port secondary riser

5.3.15 Cable routing: 8NVMe box 1+2 to type-a controller

5.3.16 Cable routing: 8SFF box 2 to type-a controller

5.3.17 Cable routing: 8SFF box 3 to 2-port primary type-p controller

5.3.18 Cable routing: 8SFF box 2 to 2-port primary type-p controller

5.3.19 Cable routing: 2SFF side-by-side to primary type-p controller

5.3.20 Cable routing: 8SFF 4-port box 1 to 4-port secondary type-p controller

5.3.21 Cable routing: 8SFF 4-port box 2 to 4-port primary type-p controller

5.3.22 Cable routing: 8SFF 4-port box 3 to 4-port primary type-p controller

5.3.23 Cable routing: 8SFF box 1+2+3 to 4-port secondary type-p controller

5.3.24 Cable routing: 8SFF box 1+2+3 to 4-port primary type-p controller

5.3.25 Cable routing: 4LFF SAS/SATA box 7 to 4-port type-a controller

5.4 Cable routing: Front I/O cabling

5.5 Cable routing: Serial port

5.6 Cable routing: OCV NVMe enablement

6 Software and configuration utilities

6.1 Server mode

6.2 Product QuickSpecs

6.3 Active Health System Viewer

6.3.1 Active Health System

6.3.1.1 Active Health System data collection

6.3.1.2 Active Health System Log

6.4 HPE iLO 5

6.4.1 iLO Federation

6.4.2 iLO Service Port

6.4.3 iLO RESTful API

6.4.4 RESTful Interface Tool

6.4.5 iLO Amplifier Pack

6.5 Integrated Management Log

6.6 Intelligent Provisioning

6.7 Management security

6.8 Scripting Toolkit for Windows and Linux

6.9 HPE Message Passing Interface

6.10 HPE Performance Cluster Manager

6.11 UEFI System Utilities

6.11.1 Selecting the boot mode

6.11.2 Secure Boot

6.11.3 Launching the Embedded UEFI Shell

6.12 HPE Smart Storage Administrator

6.12.1 Smart Storage Administrator

6.13 HPE InfoSight for servers

6.14 USB support

6.14.1 External USB functionality

6.15 Redundant ROM support

6.15.1 Safety and security benefits

6.16 Keeping the system current

6.16.1 Updating firmware or system ROM

6.16.1.1 Service Pack for ProLiant

6.16.1.1.1 Smart Update Manager

6.16.1.1.2 Integrated Smart Update Tools

6.16.1.2 Updating firmware from the System Utilities

6.16.1.3 Updating the firmware from the UEFI Embedded Shell

6.16.1.4 Online Flash components

6.16.2 Drivers

6.16.3 Software and firmware

6.16.4 Operating system version support

6.16.5 HPE Pointnext Portfolio

6.16.6 Proactive notifications

7 Troubleshooting

7.1 NMI functionality

7.2 Troubleshooting resources

8 Battery replacement

9 Specifications

9.1 Environmental specifications

9.2 Mechanical specifications

9.3 Power supply specifications

9.3.1 HPE 800 W Flex Slot Universal Hot-plug Low Halogen Power Supply

9.3.2 HPE 800 W Flex Slot Platinum Hot-plug Low Halogen Power Supply

9.3.3 HPE 800 W Flex Slot Titanium Hot-plug Low Halogen Power Supply

9.3.4 HPE 800 W Flex Slot -48 VDC Hot-plug Low Halogen Power Supply

9.3.5 HPE 1600 W Flex Slot Platinum Hot-plug Low Halogen Power Supply

9.3.6 HPE 1600 W Flex Slot -48 VDC Hot-plug Power Supply

10 Support and other resources

10.1 Accessing Hewlett Packard Enterprise Support

10.2 Accessing updates

10.3 Remote support

10.4 Warranty information

10.5 Regulatory information

10.6 Documentation feedback

Component identification



Front panel components

SFF front panel components

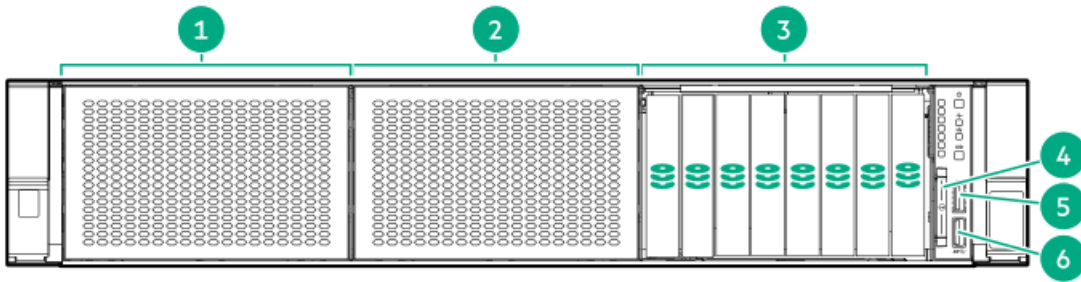

Item	Description
1	Box 1 (optional drives or universal media bay)
2	Box 2 (optional drives)
3	Box 3 Drives 1-8
4	Serial number/iLO information pull tab or optional Systems Insight Display
5	iLO Service port
6	USB 3.0 port

Universal media bay components

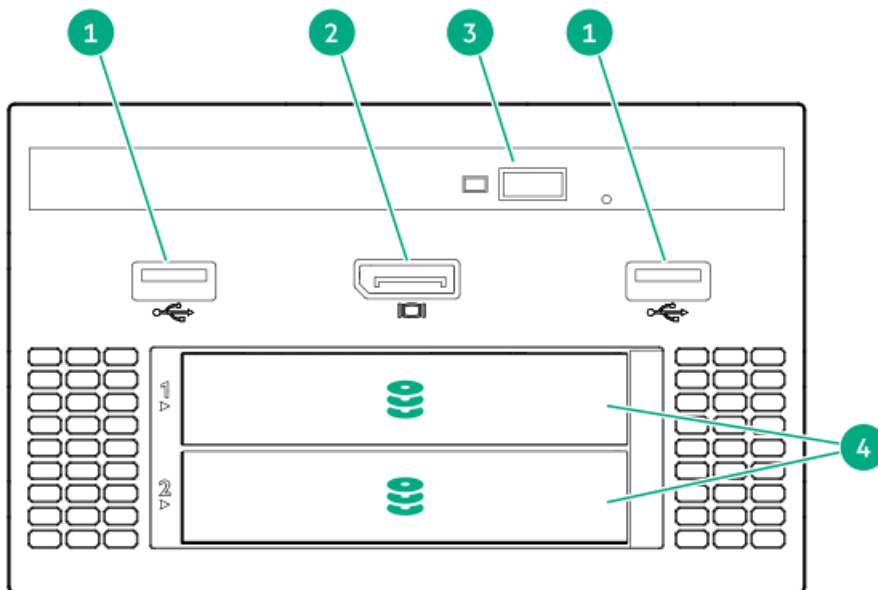

Item	Description
1	USB 2.0 port
2	Video display port
3	Optical disc drive (optional)
4	Drives (optional)

12-drive LFF front panel components

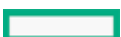



Item	Description
1	Drive bays or Optical/video/USB (optional)
2	Drive bays (optional)
3	Drive bays

8-drive LFF model front panel components

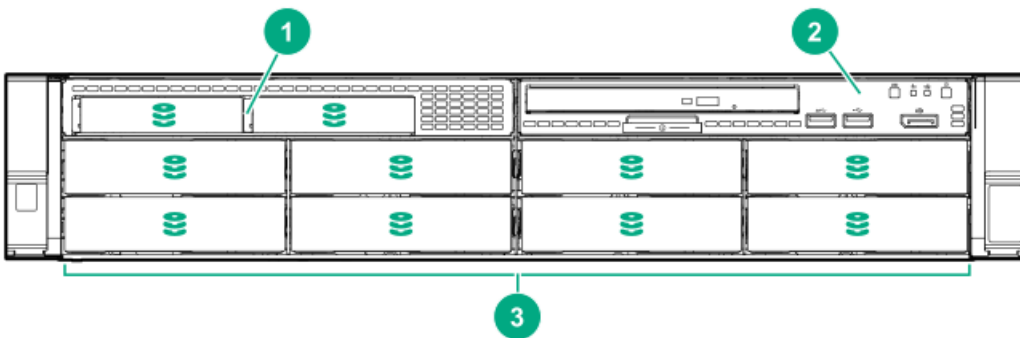

Item	Description
1	2 SFF module (optional)
2	LFF power switch module
3	Drive bays

LFF power switch module components

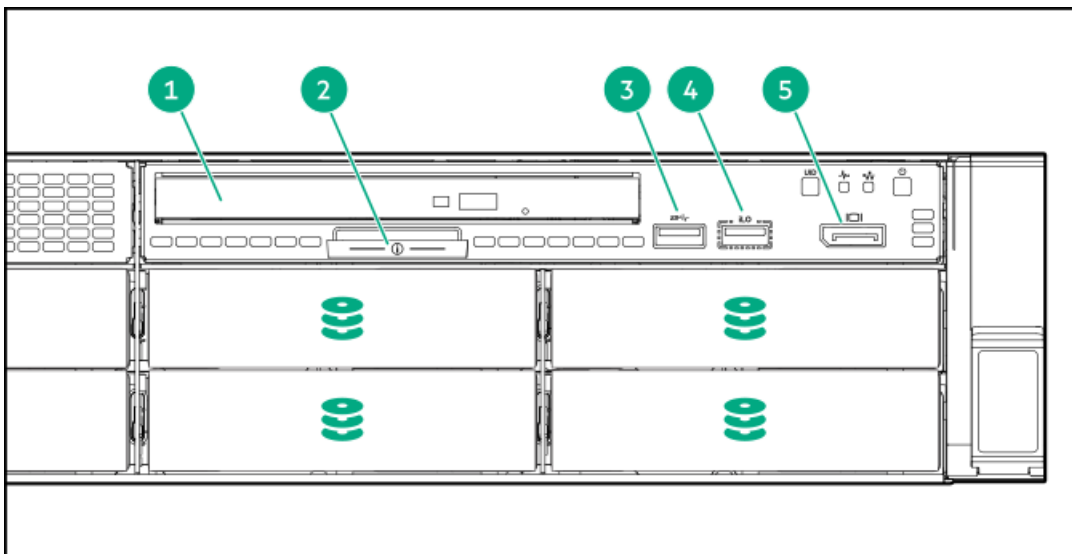

Item	Description
1	Optical disk drive
2	Serial number/iLO information pull tab

Item	Description
3	USB 3.0 port
4	iLO Service port
5	Display port



Front panel LEDs and buttons

SFF front panel LEDs and buttons

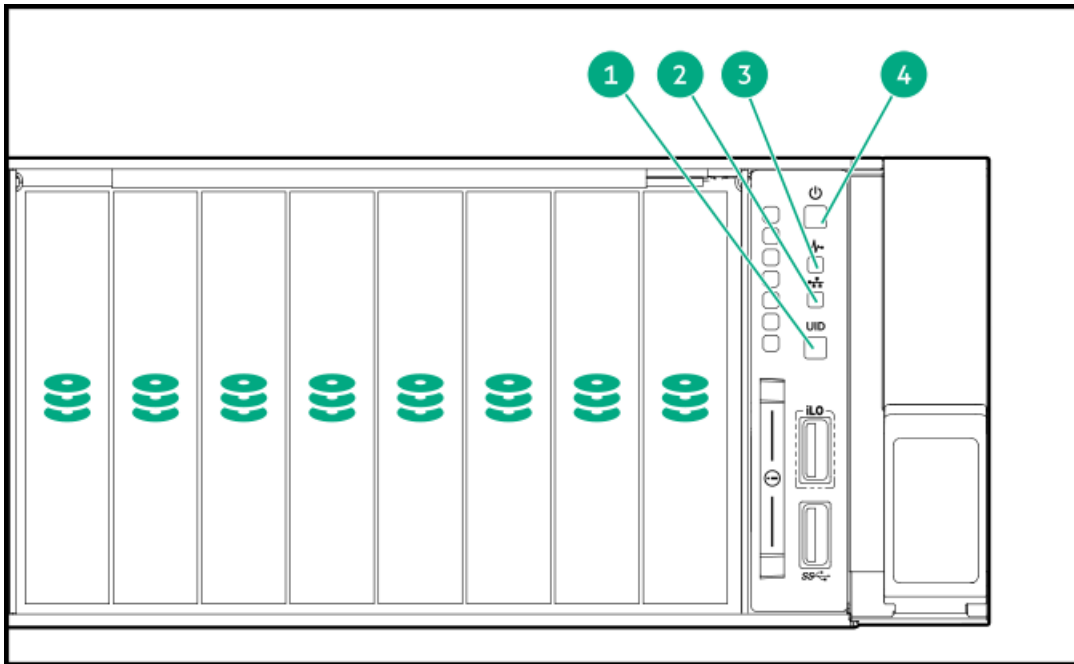

Item	Description	Status
1	UID button/LED ¹	<ul style="list-style-type: none"> • Solid blue = Activated • Flashing blue: <ul style="list-style-type: none"> ◦ 1 Hz/cycle per sec = Remote management or firmware upgrade in progress ◦ 4 Hz/cycle per sec = iLO manual reboot sequence initiated ◦ 8 Hz/cycle per sec = iLO manual reboot sequence in progress ◦ Off = Deactivated
2	NIC status LED ¹	<ul style="list-style-type: none"> • Solid green = Link to network • Flashing green (1 Hz/cycle per sec) = Network active • Off = No network activity
3	Health LED ¹	<ul style="list-style-type: none"> • Solid green = Normal • Flashing green (1 Hz/cycle per sec) = iLO is rebooting • Flashing amber = System degraded • Flashing red (1 Hz/cycle per sec) = System critical ²
4	Power On/Standby button and system power LED ¹	<ul style="list-style-type: none"> • Solid green = System on • Flashing green (1 Hz/cycle per sec) = Performing power on sequence • Solid amber = System in standby • Off = No power present ³

- ¹ When all four LEDs described in this table flash simultaneously, a power fault has occurred.
- ² If the health LED indicates a degraded or critical state, review the system IML or use iLO to review the system health status.
- ³ Facility power is not present, the power cord is not attached, no power supplies are installed, power supply failure has occurred, or the power button cable is disconnected.

12 LFF front panel LEDs and buttons

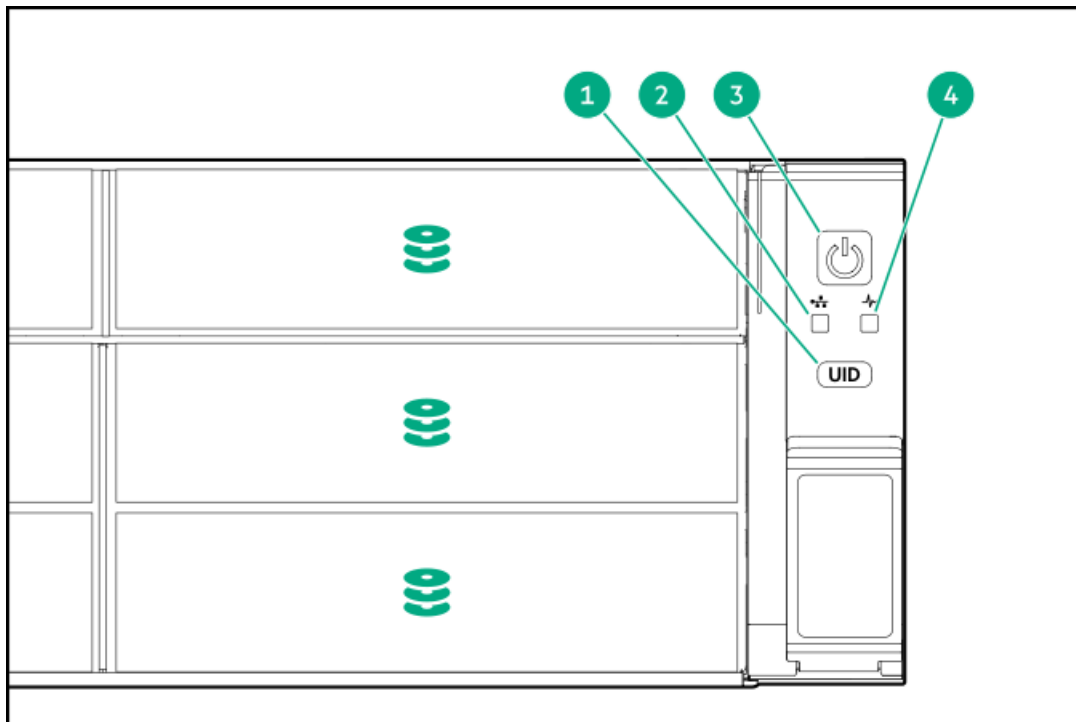

Item	Description	Status
1	UID button/LED ¹	<ul style="list-style-type: none"> • Solid blue = Activated • Flashing blue: <ul style="list-style-type: none"> ◦ 1 Hz/cycle per sec = Remote management or firmware upgrade in progress ◦ 4 Hz/cycle per sec = iLO manual reboot sequence initiated ◦ 8 Hz/cycle per sec = iLO manual reboot sequence in progress • Off = Deactivated
2	NIC status LED ¹	<ul style="list-style-type: none"> • Solid green = Link to network • Flashing green (1 Hz/cycle per sec) = Network active • Off = No network activity
3	Power On/Standby button and system power LED ¹	<ul style="list-style-type: none"> • Solid green = System on • Flashing green (1 Hz/cycle per sec) = Performing power on sequence • Solid amber = System in standby • Off = No power present ²

Item	Description	Status
4	Health LED ¹	<ul style="list-style-type: none"> • Solid green = Normal • Flashing green (1 Hz/cycle per sec) = iLO is rebooting • Flashing amber = System degraded • Flashing red (1 Hz/cycle per sec) = System critical ³

¹ When all four LEDs described in this table flash simultaneously, a power fault has occurred.

² Facility power is not present, the power cord is not attached, no power supplies are installed, power supply failure has occurred, or the power button cable is disconnected.

³ If the health LED indicates a degraded or critical state, review the system IML or use iLO to review the system health status.

LFF power switch module LEDs and buttons

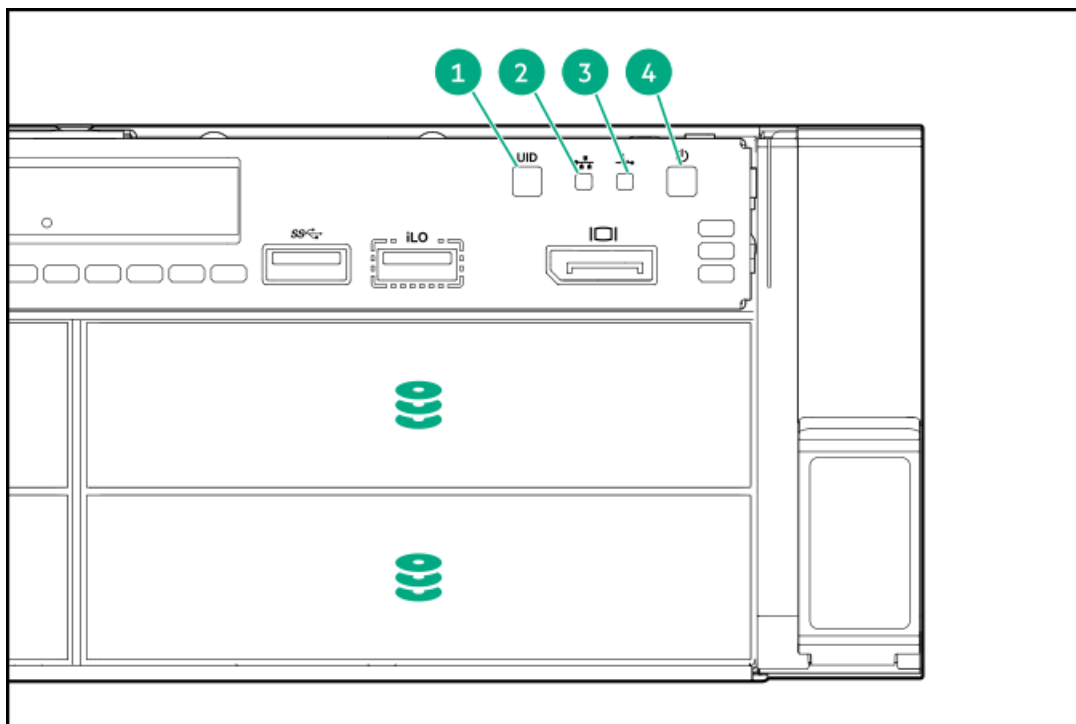

Item	Description	Status
1	UID button/LED ¹	<ul style="list-style-type: none"> • Solid blue = Activated • Flashing blue: <ul style="list-style-type: none"> ◦ 1 Hz/cycle per sec = Remote management or firmware upgrade in progress ◦ 4 Hz/cycle per sec = iLO manual reboot sequence initiated ◦ 8 Hz/cycle per sec = iLO manual reboot sequence in progress • Off = Deactivated
2	NIC status LED ¹	<ul style="list-style-type: none"> • Solid green = Link to network • Flashing green (1 Hz/cycle per sec) = Network active • Off = No network activity

Item	Description	Status
3	Health LED ¹	<ul style="list-style-type: none"> • Solid green = Normal • Flashing green (1 Hz/cycle per sec) = iLO is rebooting • Flashing amber = System degraded • Flashing red (1 Hz/cycle per sec) = System critical ²
4	Power On/Standby button and system power LED ¹	<ul style="list-style-type: none"> • Solid green = System on • Flashing green (1 Hz/cycle per sec) = Performing power on sequence • Solid amber = System in standby • Off = No power present ³

¹ When all four LEDs described in this table flash simultaneously, a power fault has occurred.

² If the health LED indicates a degraded or critical state, review the system IML or use iLO to review the system health status.

³ Facility power is not present, the power cord is not attached, no power supplies are installed, power supply failure has occurred, or the power button cable is disconnected.

UID button functionality

The UID button can be used to display the Server Health Summary when the server will not power on. For more information, see the latest HPE iLO 5 User Guide on the [Hewlett Packard Enterprise website](#).



Front panel LED power fault codes

The following table provides a list of power fault codes, and the subsystems that are affected. Not all power faults are used by all servers.

Subsystem	LED behavior
System board	1 flash
Processor	2 flashes
Memory	3 flashes
Riser board PCIe slots	4 flashes
OCP adapter	5 flashes
Storage controller	6 flashes
System board PCIe slots	7 flashes
Power backplane	8 flashes
Storage backplane	9 flashes
Power supply	10 flashes
PCIe expansion cards installed in riser board	11 flashes
Chassis	12 flashes
GPU card	13 flashes



Systems Insight Display LEDs

The Systems Insight Display LEDs represent the system board layout. The display enables diagnosis with the access panel installed.

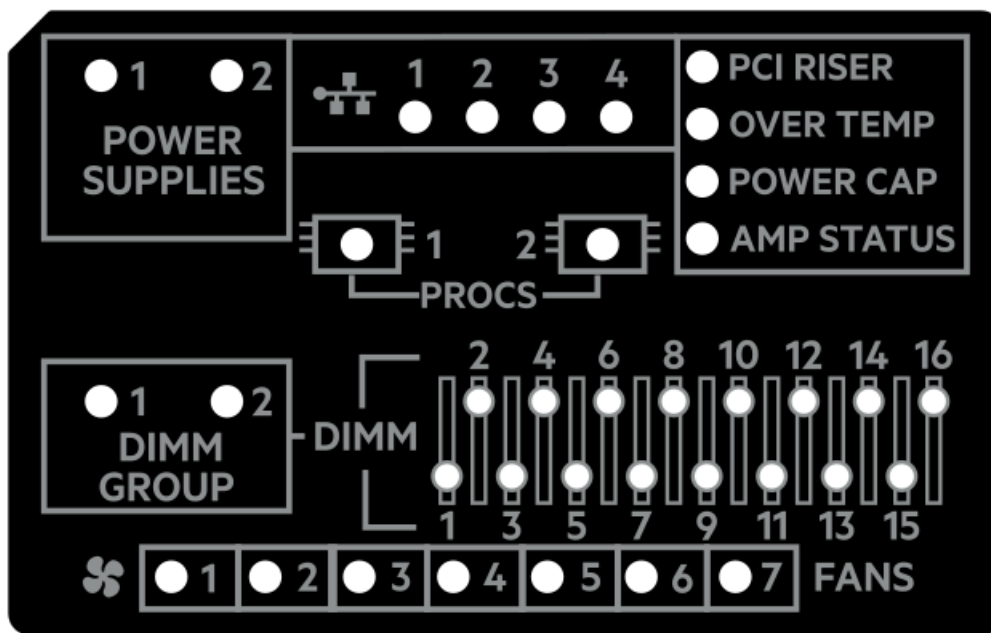

Description	Status
Processor LEDs	Off = Normal Amber = Failed processor
DIMM LEDs	Off = Normal Amber = Failed DIMM or configuration issue
Fan LEDs	Off = Normal Amber = Failed fan or missing fan
NIC LEDs ¹	Off = No link to network Solid green = Network link Flashing green = Network link with activity If power is off, the front panel LED is not active. For status, see Rear panel LEDs .
Power supply LEDs	Off = Normal Solid amber = Power subsystem degraded, power supply failure, or input power lost.
PCI riser LED	Off = Normal Amber = Incorrectly installed PCI riser cage
Over temp LED	Off = Normal Amber = High system temperature detected
Power cap LED	Off = System is in standby, or no cap is set. Solid green = Power cap applied

Description	Status
Amp Status LED	Off = AMP modes disabled
	Solid green = AMP mode enabled
	Solid amber = Failover
	Flashing amber = Invalid configuration

¹ Embedded NIC ports are not equipped on the server. NIC LEDs on the Systems Insight Display will flash based on the network adapter port activity. In the case of a dual-port adapters, only NIC LED 1 and 2 will illuminate to correspond with the activity of the respective network ports.

When the health LED on the front panel illuminates either amber or red, the server is experiencing a health event. For more information on the combination of these LEDs, see [Systems Insight Display combined LED descriptions](#).



Systems Insight Display combined LED descriptions

The combined illumination of the following LEDs indicates a system condition:

- Systems Insight Display LEDs
- System power LED
- Health LED

Systems Insight Display LED and color	Health LED	System power LED	Status
Processor (amber)	Red	Amber	One or more of the following conditions might exist: <ul style="list-style-type: none"> • Processor in socket X has failed. • Processor X is not installed in the socket. • Processor X is unsupported. • ROM detects a failed processor during POST.
Processor (amber)	Amber	Green	Processor in socket X is in a pre-failure condition.
DIMM (amber)	Red	Green	One or more DIMMs have failed.
DIMM (amber)	Amber	Green	DIMM in slot X is in a pre-failure condition.
Over temp (amber)	Amber	Green	The Health Driver has detected a cautionary temperature level.
Over temp (amber)	Red	Amber	The server has detected a hardware critical temperature level.
PCI riser (amber)	Red	Green	The PCI riser cage is not seated properly.
Fan (amber)	Amber	Green	One fan has failed or has been removed.
Fan (amber)	Red	Green	Two or more fans have failed or been removed.
Power supply (amber)	Red	Amber	One or more of the following conditions might exist: <ul style="list-style-type: none"> • Only one power supply is installed and that power supply is in standby. • Power supply fault. • System board fault.
Power supply (amber)	Amber	Green	One or more of the following conditions might exist: <ul style="list-style-type: none"> • Redundant power supply is installed and only one power supply is functional. • AC power cord is not plugged into redundant power supply. • Redundant power supply fault. • Power supply mismatch at POST or power supply mismatch through hot-plug addition.
Power cap (off)	—	Amber	Standby.

Systems Insight Display LED and color	Health LED	System power LED	Status
Power cap (green)	—	Flashing green	Waiting for power.
Power cap (green)	—	Green	Power is available.
Power cap (flashing amber)	—	Amber	Power is not available.

i IMPORTANT: If more than one DIMM slot LED is illuminated, further troubleshooting is required. Test each bank of DIMMs by removing all other DIMMs. Isolate the failed DIMM by replacing each DIMM in a bank with a known working DIMM.

Rear panel components

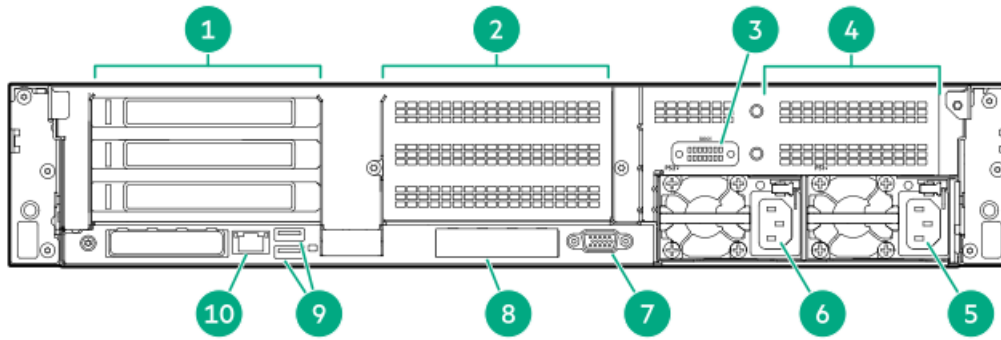

Item	Description
1	Primary riser slots 1–3 (optional drive cage)
2	Secondary riser slots 4–6 (optional drive cage)
3	Serial port (optional) ¹
4	Tertiary riser slots 7–8 (optional drive cage)
5	Power supply 1
6	Power supply 2
7	Video (VGA) port
8	OCP 3.0 adapter (optional)
9	USB 3.0 connectors
10	iLO Management Port

¹ When a secondary or tertiary riser cage is installed as shown, the serial port can be installed in the riser slot 8.

Rear panel LEDs

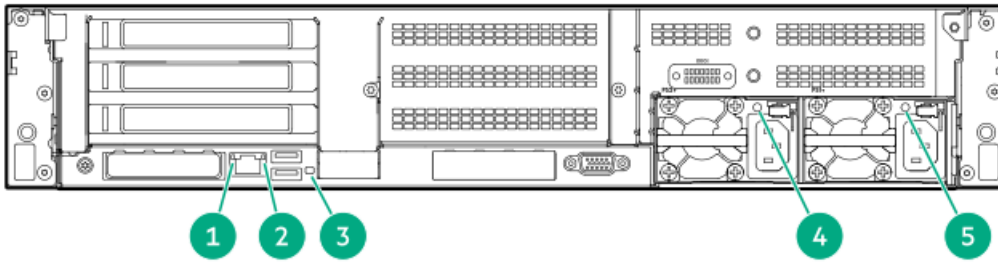

Item	Description	Status
1	Link LED	<ul style="list-style-type: none">• Off = No network link• Green = Network link
2	Status LED	<ul style="list-style-type: none">• Off = No network activity• Solid green = Link to network• Flashing green = Network activity
3	UID LED	<ul style="list-style-type: none">• Off = Deactivated• Solid blue = Activated• Flashing blue = System is being managed remotely
4-5	Power supply LED	<ul style="list-style-type: none">• Off = System is off or power supply has failed• Solid green = Normal

System board components

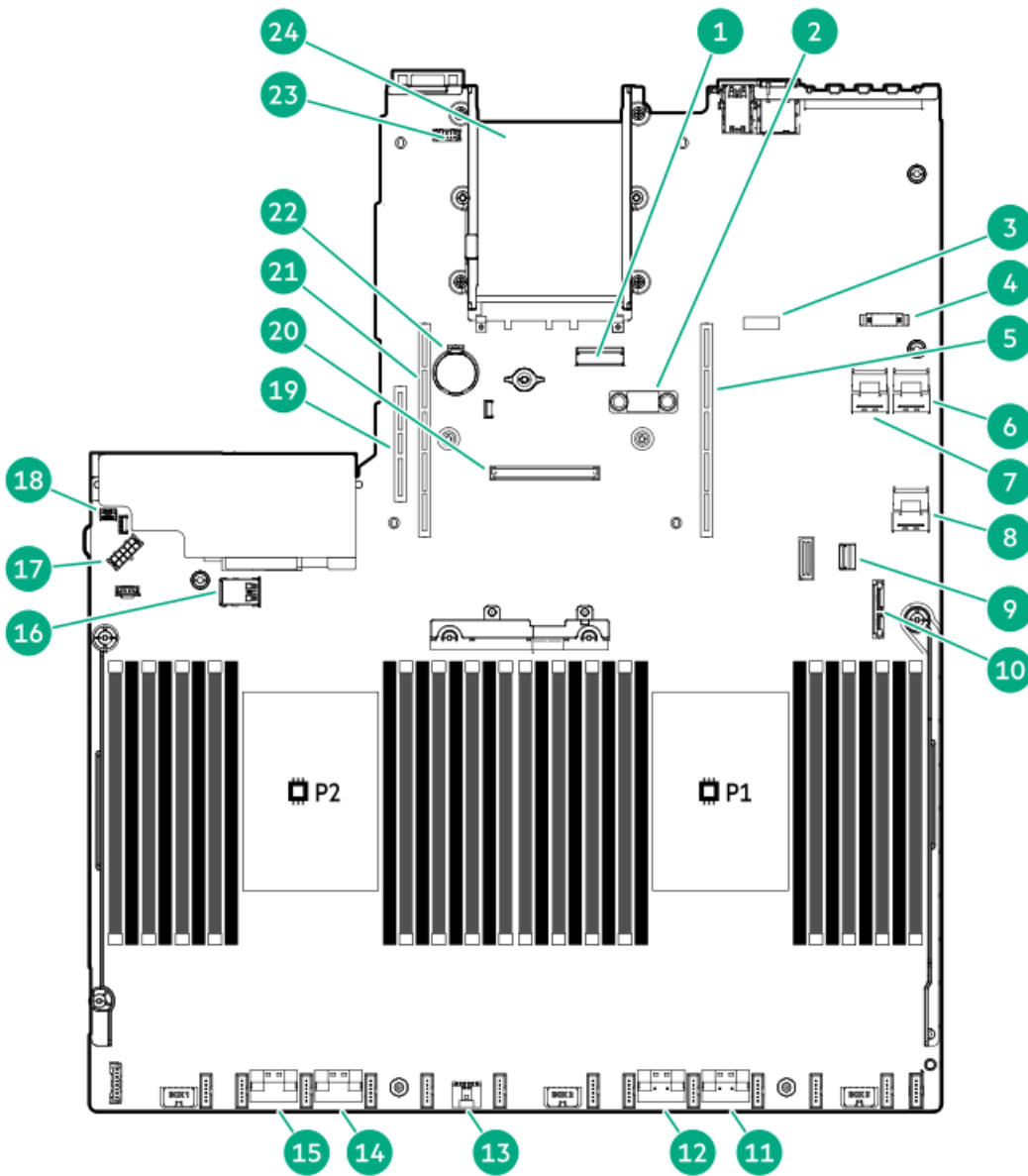

Item	Description
1	x8 Slimline connector
2	TPM connector
3	System maintenance switch
4	Front display port/USB 2.0 connector
5	Primary (processor 1) PCIe riser connector
6	x4 SATA port 2
7	x4 SATA port 1
8	x4 SATA port 3
9	Front power/USB 3.0 connector
10	SATA optical port 4
11	x8 NVMe port 2A
12	x8 NVMe port 1A
13	Energy pack connector
14	x8 NVMe port 2B
15	x8 NVMe port 1B

Item	Description
16	Dual internal USB 3.0 connector
17	Drive backplane power connector
18	Chassis Intrusion Detection connector
19	Tertiary (processor 2) PCIe riser connector
20	Type-a storage controller slot
21	Secondary (processor 2) PCIe riser connector
22	System battery
23	Serial port connector
24	OCP 3.0 adapter bay

Heatsink and socket components

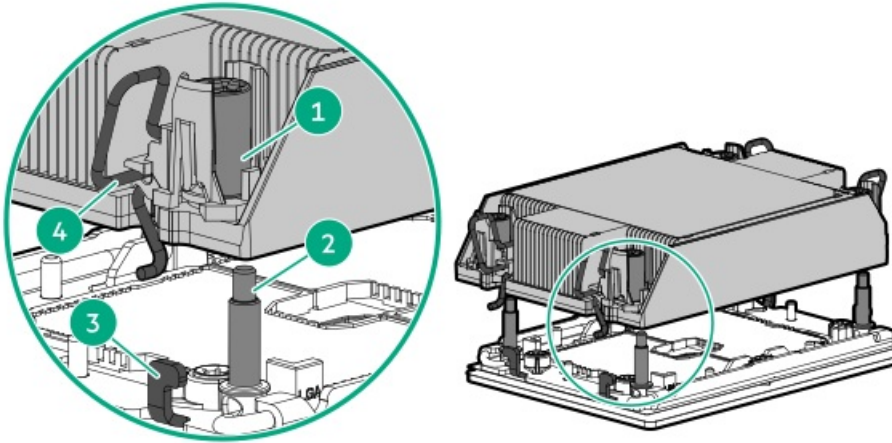

Item	Description
1	Heatsink nuts
2	Alignment screws
3	Latch tabs
4	Heatsink latches

DIMM label identification

To determine DIMM characteristics, see the label attached to the DIMM. The information in this section helps you to use the label to locate specific information about the DIMM.

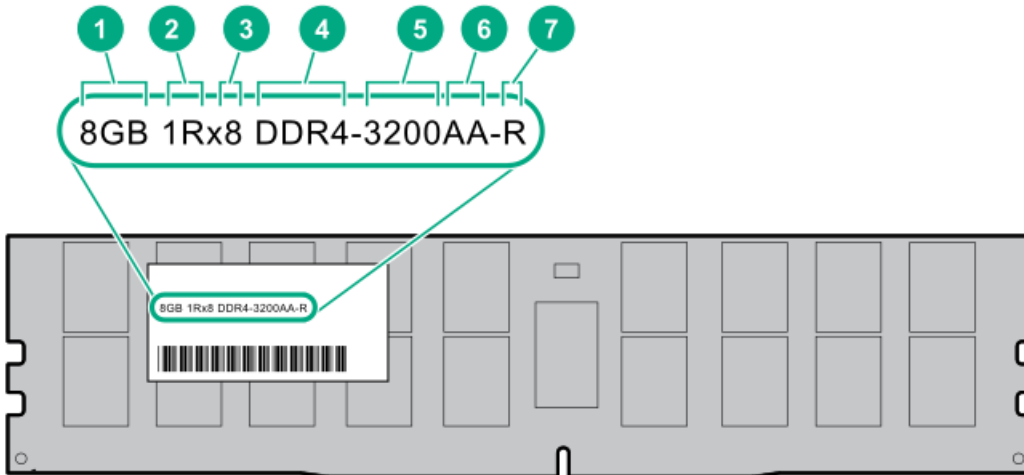

Item	Description	Example
1	Capacity	8 GB 16 GB 32 GB 64 GB 128 GB 256 GB
2	Rank	1R = Single rank 2R = Dual rank 4R = Quad rank 8R = Octal rank
3	Data width on DRAM	x4 = 4-bit x8 = 8-bit
4	Memory generation	PC4 = DDR4
5	Maximum memory speed	3200 MT/s
6	CAS latency	AA = CAS 22-22-22 AA = CAS 26-22-22 (for 3DS LRDIMM)
7	DIMM type	R = RDIMM (registered) L = LRDIMM (load reduced)

For more information about product features, specifications, options, configurations, and compatibility, see the HPE DDR4 SmartMemory QuickSpecs on the Hewlett Packard Enterprise website (<https://www.hpe.com/support/DDR4SmartMemoryQS>).

Intel Optane persistent memory 200 series for HPE label identification

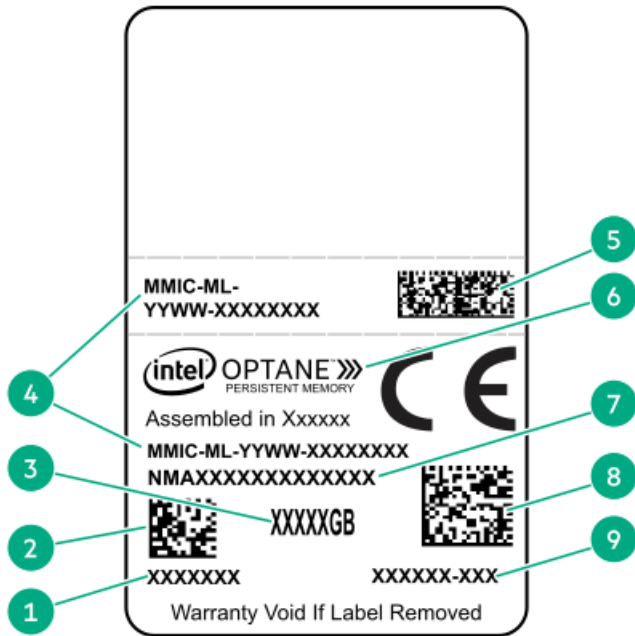

Item	Description	Example
1	Work Order Number	XXXXXXX
2	Work Order Number Barcode	XXXXXXX
3	Capacity	128 GB 256 GB 512 GB
4	Unique ID number	8089-A2-1802-1234567A
5	Serial Number and Part Number Barcode	S8089A218040000168APNMAXXXXXXXXXXXXXX
6	Product Name	Intel® Optane™ persistent memory
7	Part Number	1234567A
8	Serial Number Barcode	8089-A2-1802-1234567A
9	PBA Number	XXXXXX-XXX

For more information about product features, specifications, options, configurations, and compatibility, see the product QuickSpecs on the Hewlett Packard Enterprise website (<https://www.hpe.com/support/persistentmemoryQS>).

DIMM slot locations

DIMM slots are numbered sequentially (1 through 16) for each processor.

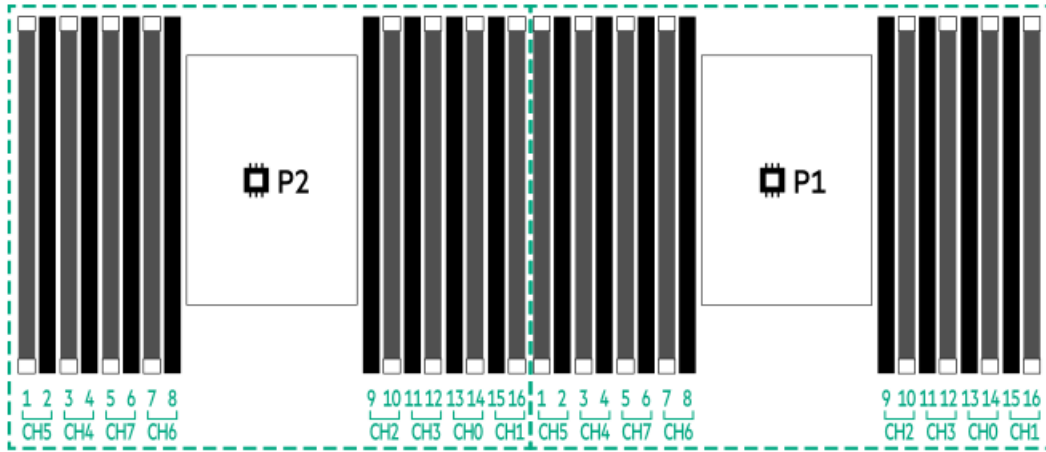

System maintenance switch descriptions

Position	Default	Function
S1 ¹	Off	Off = iLO security is enabled. On = iLO security is disabled.
S2	Off	Reserved
S3	Off	Reserved
S4	Off	Reserved
S5 ¹	Off	Off = Power-on password is enabled. On = Power-on password is disabled.
S6 ^{1, 2, 3}	Off	Off = No function On = Restore default manufacturing settings
S7	Off	Reserved
S8	—	Reserved
S9	—	Reserved
S10	—	Reserved
S11	—	Reserved
S12	—	Reserved

¹ To access the redundant ROM, set S1, S5, and S6 to On.

² When the system maintenance switch position 6 is set to the On position, the system is prepared to restore all configuration settings to their manufacturing defaults.

³ When the system maintenance switch position 6 is set to the On position and Secure Boot is enabled, some configurations cannot be restored.

For more information, see [Secure Boot](#).

Drive box identification

Front boxes

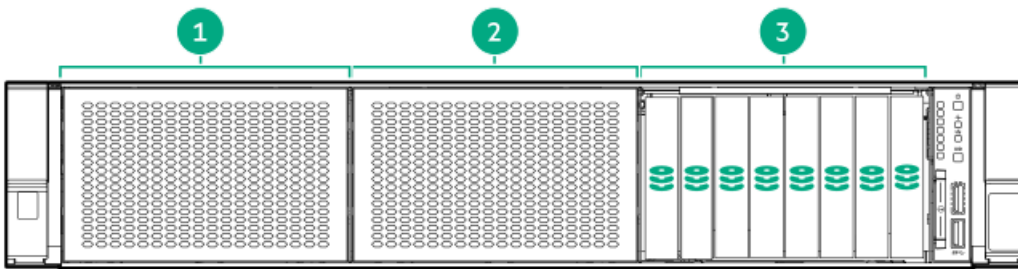

Item	Description
------	-------------

- | | |
|---|-------|
| 1 | Box 1 |
| 2 | Box 2 |
| 3 | Box 3 |



Item	Description
------	-------------

- | | |
|---|-------|
| 1 | Box 1 |
| 2 | Box 2 |
| 3 | Box 3 |

Rear boxes

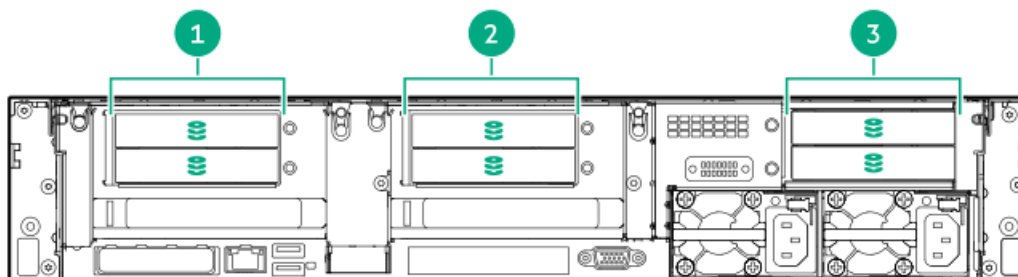

Item	Description
------	-------------

- | | |
|---|-------|
| 1 | Box 4 |
| 2 | Box 5 |
| 3 | Box 6 |

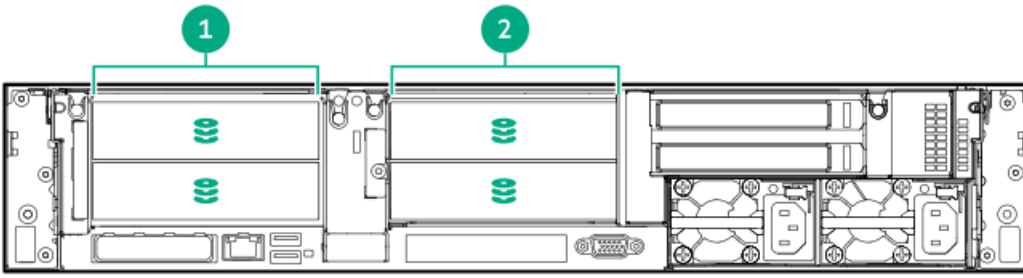

Item Description

1	Box 4
2	Box 5

Midplane box (LFF)

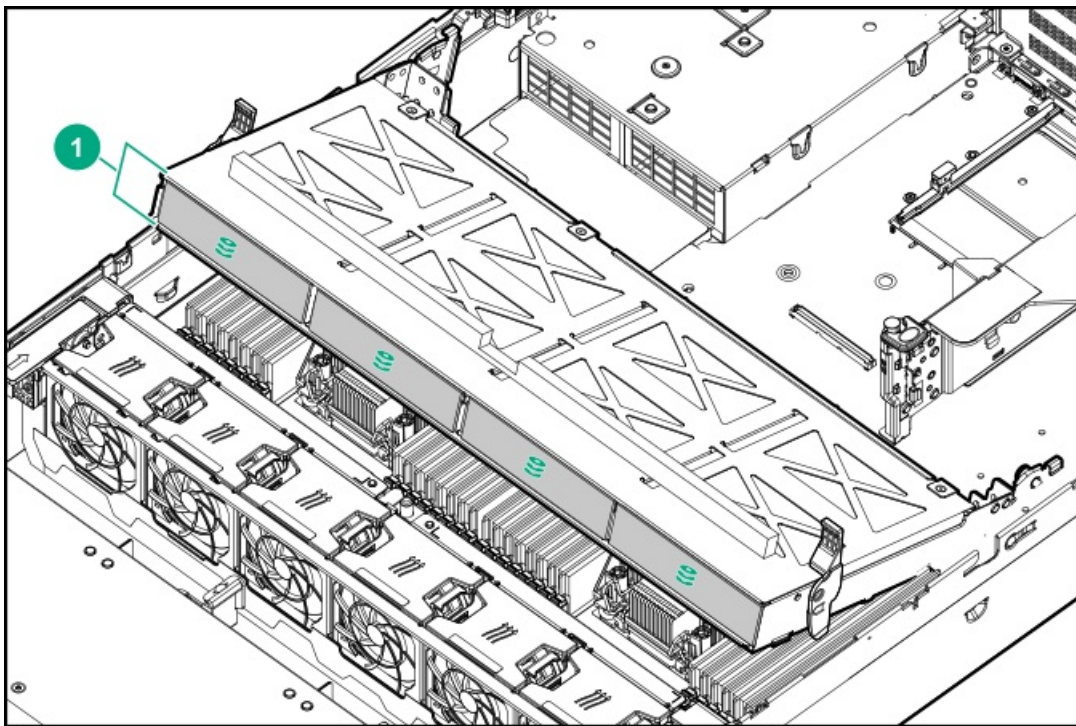

Item Description

1	Box 7
---	-------

Midplane box (SFF)

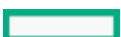

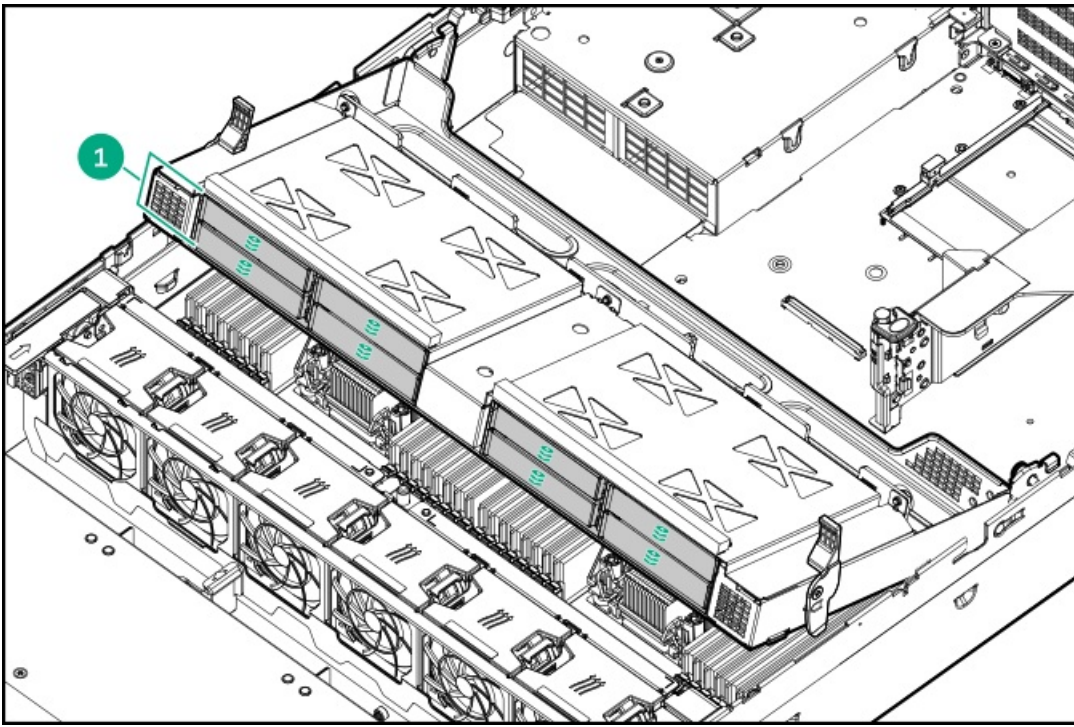

Item	Description
------	-------------

1	Box 7
---	-------



Drive numbering

When the drive backplane is connected directly to a storage controller, then each drive box starts at 1. The following images are examples of common configurations.

24 SFF

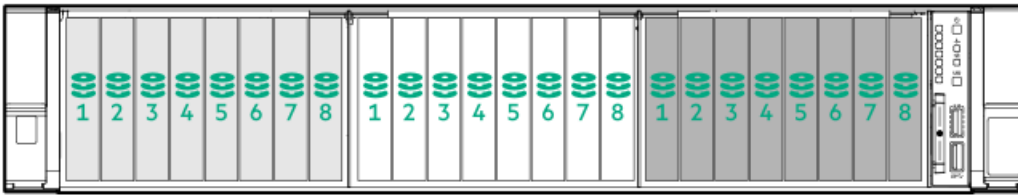

12 SFF



12 LFF



6 SFF rear panel



2x 2 LFF rear panel





Universal media bay

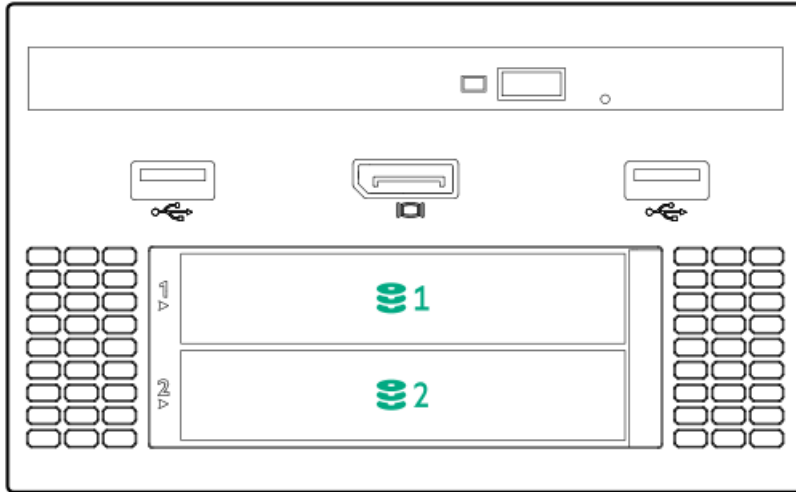

8 LFF + Universal media bay, optional 2 SFF, and optical drive

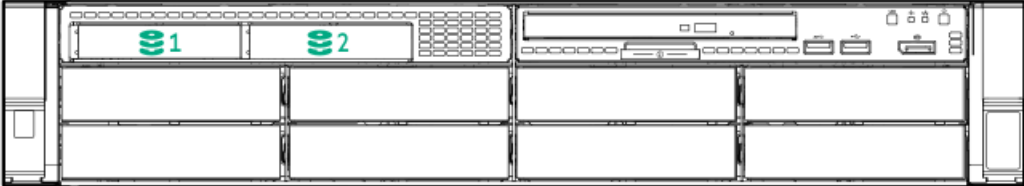

Midplane box LFF



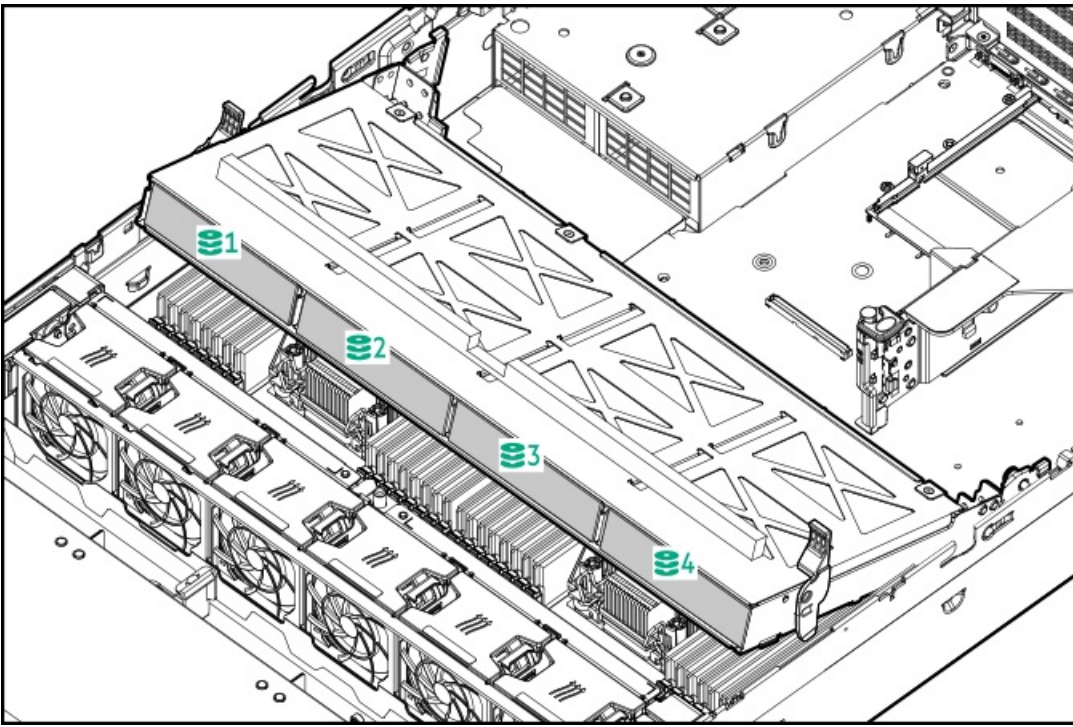

Midplane box SFF

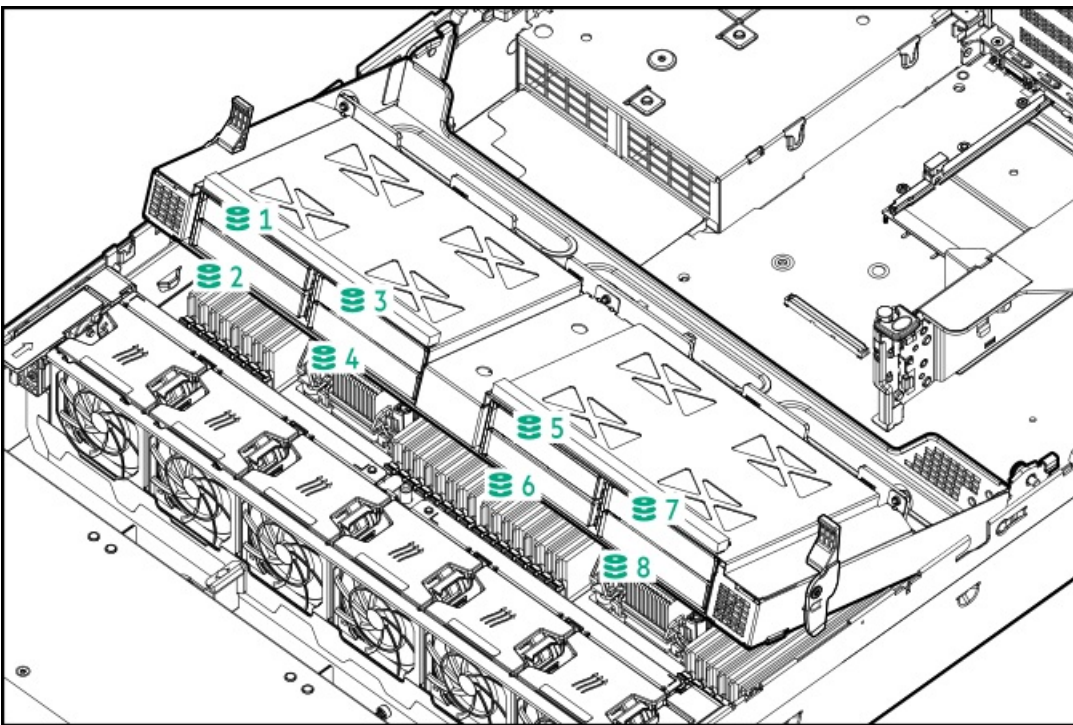

HPE Basic Drive LED definitions

LFF low-profile drive carrier

The LFF low-profile drive carrier supports hot-plug SAS and SATA drives.

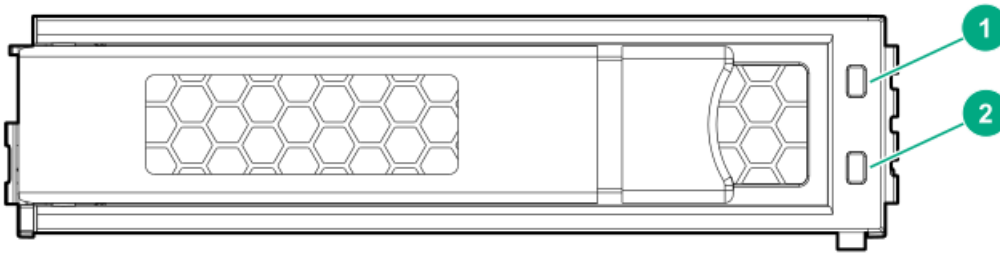

SFF basic drive carrier

The SFF basic drive carrier supports hot-plug SAS, SATA, and NVMe drives.

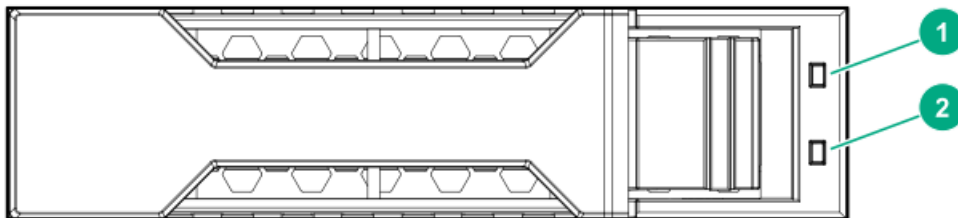

Item	LED	Status	Definition
1	Fault/Locate	Solid amber	This drive has failed, is unsupported, or is invalid.
		Solid blue	The drive is operating normally and being identified by a management application.
		Flashing amber/blue (1 flash per second)	The drive has failed, or a predictive failure alert has been received for this drive. The drive has also been identified by a management application.
		Flashing amber (1 flash per second)	A predictive failure alert has been received for this drive. Replace the drive as soon as possible.
2	Online/Activity	Solid green	The drive is online and has no activity.
		Flashing green (1 flash per second)	The drive is doing one of the following: <ul style="list-style-type: none"> Rebuilding or performing a RAID Performing a stripe size migration Performing a capacity expansion Performing a logical drive extension Erasing Spare part activation
		Flashing green (4 flashes per second)	The drive is operation normally and has activity.
		Off	The drive is not configured by a RAID controller or is a spare drive.



Fan bay numbering

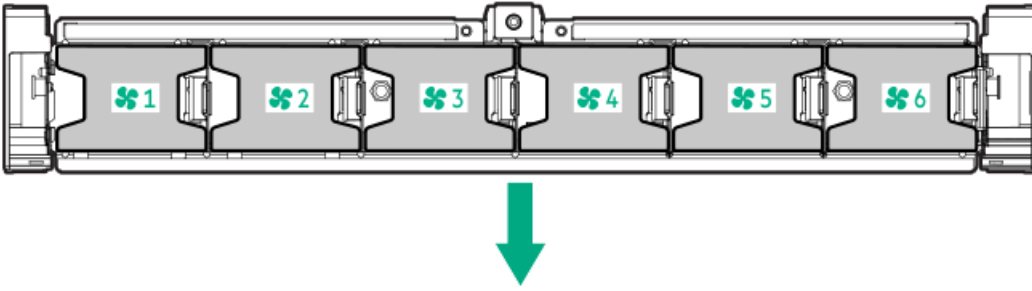

The arrow points to the front of the server.

DSC-25 2-port SFP28 card ports and LEDs

Ports

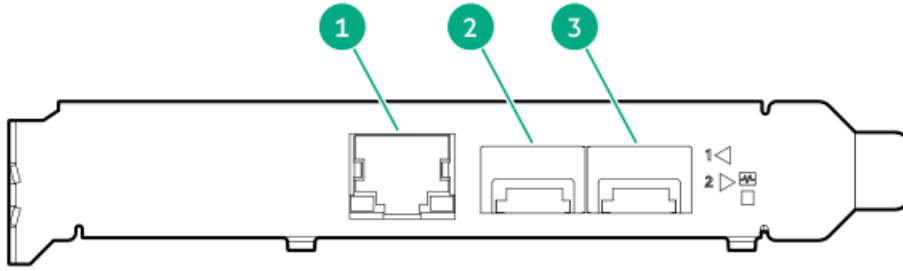

Table 1: Ports

Item	Port	Description
1	Management port	1GbE RJ45
2	Network interface port	10/25G SFP+ based
3	Network interface port	10/25G SFP+ based

LEDs

The HPE for Pensando DSP DSC-25 2p SFP28 card is a dual-port, single-slot, half-height, half-length (HHHL) SFP28 network adapter. It has LEDs for Link (L) and Activity (A) for each port. A half-height bracket is shown in the following illustration with SFP28 ports and LEDs.

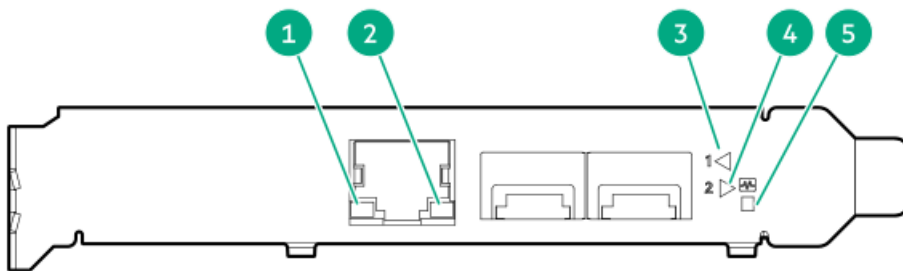

Table 2: LED indicators

Item	LED	Status	Description
1	Management Port Activity LED	Off	No activity
		Flashing	Passing traffic; flashing frequency indicates traffic intensity
2	Management Port Link LED	Off	A link has not been established
		Solid green	Valid Ethernet link
3	SFP Port 1 Link/Activity LED	Off	A link has not been established
		Solid green	Valid Ethernet link
		Flashing green	Passing traffic; flashing frequency indicates traffic intensity
		Solid amber	Link fault

Item	LED	Status	Description
4	SFP Port 2 Link/Activity LED	Off	A link has not been established
		Solid green	Valid Ethernet link
		Flashing green	Passing traffic; flashing frequency indicates traffic intensity
		Solid amber	Link fault
5	System status LED	Off	System is not powered
		Solid amber	Power is up, software has not booted yet
		Solid green	System is up and fully operational



HPE NS204i-p NVMe OS Boot Device components

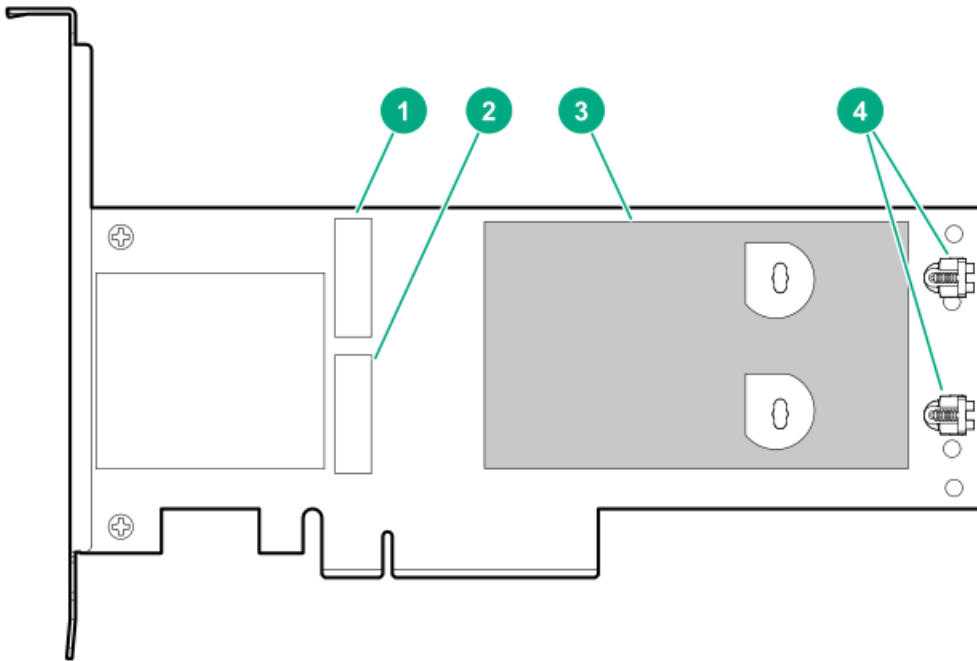

Item	Description
1	Drive bay 1
2	Drive bay 2
3	Thermal interface pad with removable liner
4	M.2 drive retaining latches

HPE NS204i-p NVMe OS Boot Device LED definitions

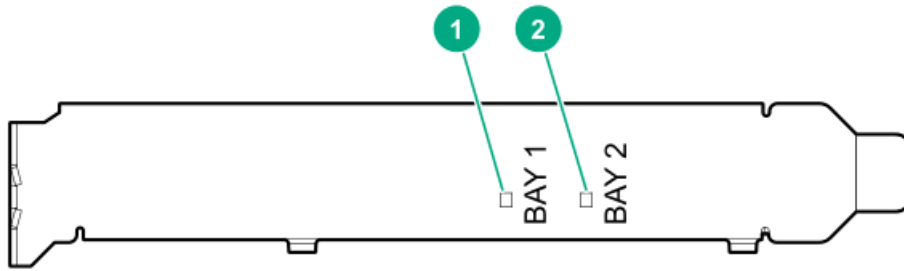

Item	Description	Fault LED status
1	Bay 1 LED	Off: Normal
2	Bay 2 LED	Flashing 1Hz: Drive predictive failure Amber: Drive failure

Power up the server

To power up the server, use one of the following methods:

- Press the Power On/Standby button.
- Use the virtual power button through iLO.

Power down the server

Before powering down the server for any upgrade or maintenance procedures, perform a backup of critical server data and programs.

i IMPORTANT:

When the server is in standby mode, auxiliary power is still being provided to the system.

To power down the server, use one of the following methods:

- Press and release the Power On/Standby button.
This method initiates a controlled shutdown of applications and the OS before the server enters standby mode.
- Press and hold the Power On/Standby button for more than 4 seconds to force the server to enter standby mode.
This method forces the server to enter standby mode without properly exiting applications and the OS. If an application stops responding, you can use this method to force a shutdown.
- Use a virtual power button selection through iLO.
This method initiates a controlled remote shutdown of applications and the OS before the server enters standby mode.

Before proceeding, verify that the server is in standby mode by observing that the system power LED is amber.

Extending the server from the rack

WARNING: To reduce the risk of personal injury or equipment damage, be sure that the rack is adequately stabilized before extending anything from the rack.

Procedure

1. Pull down the quick release levers on each side of the server.
2. If necessary, use a T-25 Torx screwdriver to loosen the shipping screws.
3. Extend the server from the rack.

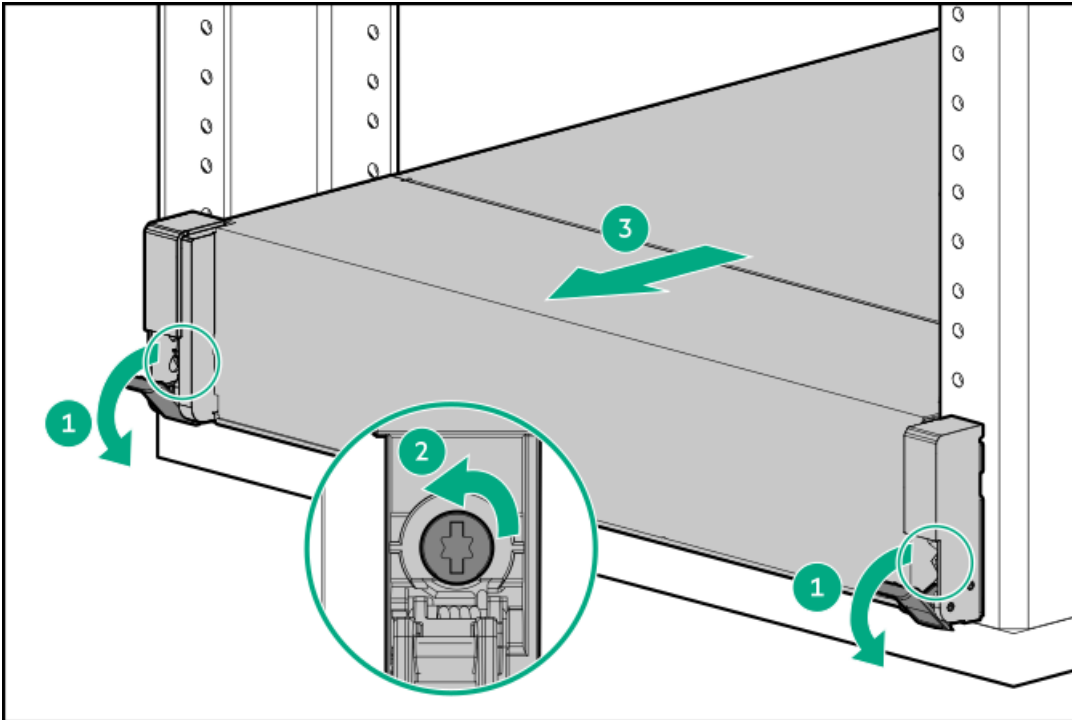

Secure cables using the cable management arm

For rack rail installation instructions, see the documentation that ships with the rack rails.

WARNING: To reduce the risk of electric shock, fire, or damage to the equipment:

- Do not insert wrong connectors into ports.
- Do not disable the power cord grounding plug. The grounding plug is an important safety feature.
- Plug the power cord into a grounded (earthed) electrical outlet that is easily accessible at all times.
- Unplug the power cord from the power supply to disconnect power to the equipment.
- Do not route the power cord where it can be walked on or pinched by items placed against it. Pay particular attention to the plug, electrical outlet, and the point where the cord extends from the server.

Procedure

1. After the server is racked, connect any peripheral devices to the server.

To identify components, see [Rear panel components](#).

2. At the rear of the server, plug in the power cord to the power supply.
3. Install the power cord anchors.

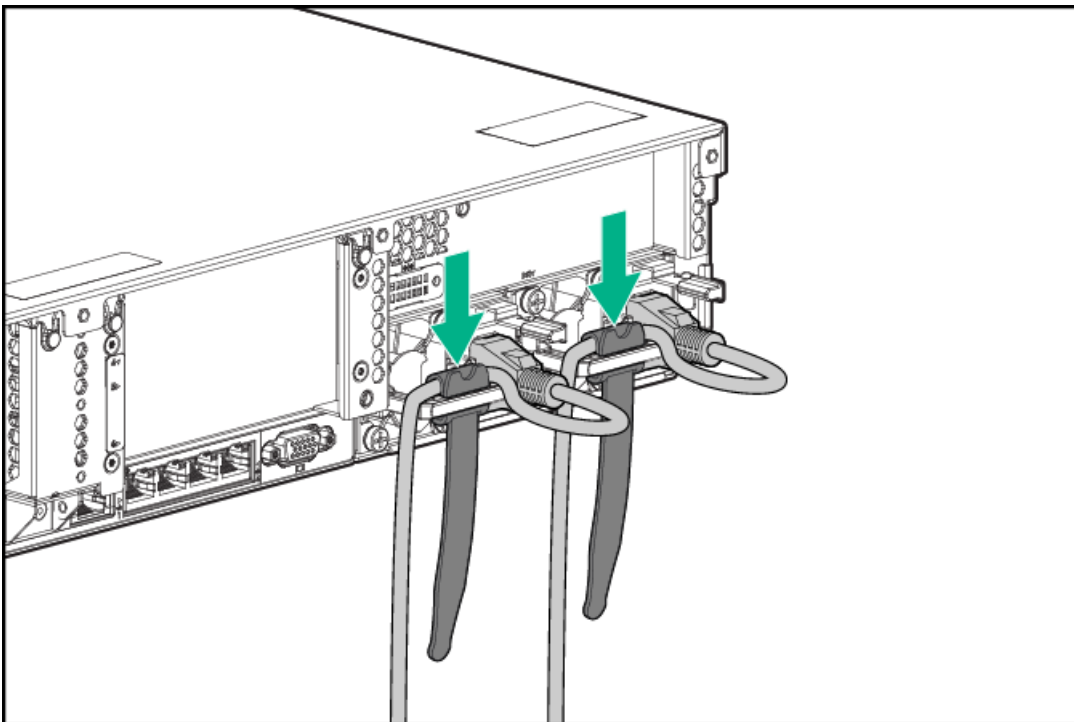

4. Secure the cables to the cable management arm.

i IMPORTANT: Leave enough slack in each of the cables to prevent damage to the cables when the server is extended from the rack.

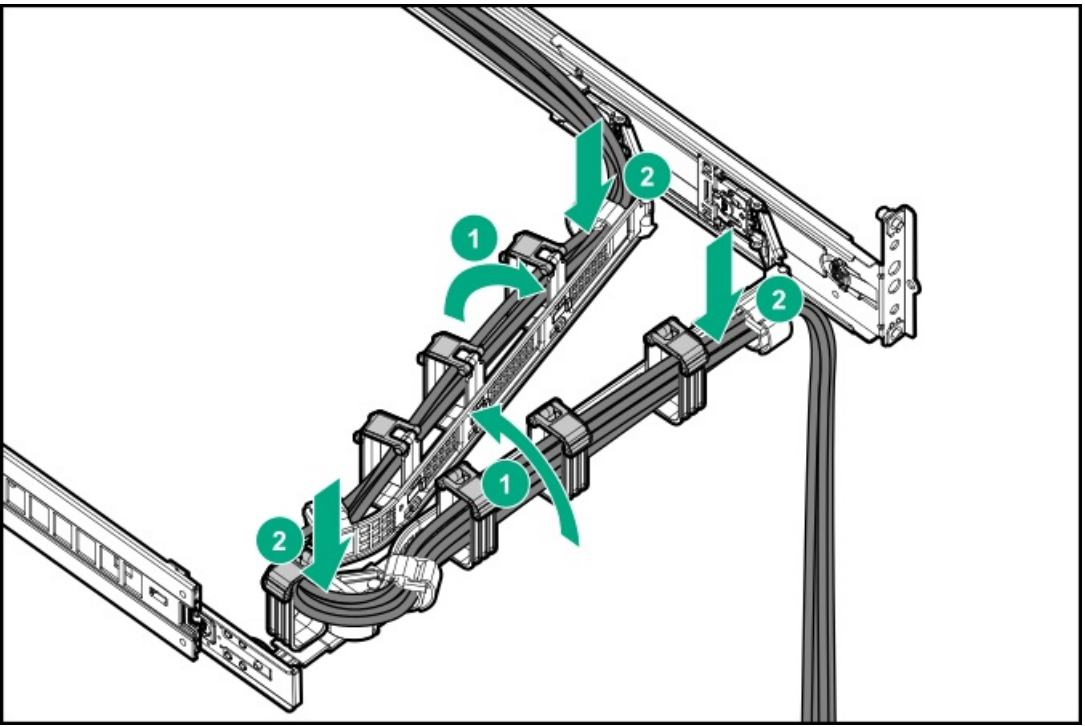

5. Connect the power cord to the AC power source.

Removing the server from the rack

To remove the server from a Hewlett Packard Enterprise, Compaq-branded, Telco, or third-party rack:

Procedure

1. [Power down the server.](#)
2. [Extend the server from the rack.](#)
3. Disconnect the cabling and remove the server from the rack.

For more information, see the documentation that ships with the rack mounting option.

4. Place the server on a sturdy, level surface.

Remove the access panel

WARNING: To reduce the risk of personal injury from hot surfaces, allow the drives, power supplies, and internal system components to cool before touching them.

△ CAUTION:

Do not operate the chassis for long periods with the access panel open or removed. Operating the chassis in this manner results in improper airflow and improper cooling that can lead to thermal damage.

Procedure

1. Power down the server.
2. If installed, release the cable management arm.
3. Remove all power:
 - a. Disconnect each power cord from the power source.
 - b. Disconnect each power cord from the server.
4. Extend the server from the rack.
5. Open or unlock the locking latch, slide the access panel to the rear of the chassis, and remove the access panel.

Install the access panel

Procedure

1. Place the access panel on top of the server with the latch open.

Allow the panel to extend past the rear of the server approximately 1.25 cm (0.5 in).

2. Push down on the latch.

The access panel slides to a closed position.

3. Tighten the security screw on the latch, if needed.



Removing the fan cage

⚠ CAUTION:

Do not operate the server for long periods with the access panel open or removed. Operating the server in this manner results in improper airflow and improper cooling that can lead to thermal damage.

i IMPORTANT: For optimum cooling, install fans in all primary fan locations.

Procedure

1. Power down the server.
2. Remove all power:
 - Disconnect each power cord from the power source.
 - Disconnect each power cord from the server.
3. Do one of the following:
 - Extend the server from the rack.
 - Remove the server from the rack.
4. Remove the access panel.
5. Remove the fan cage.

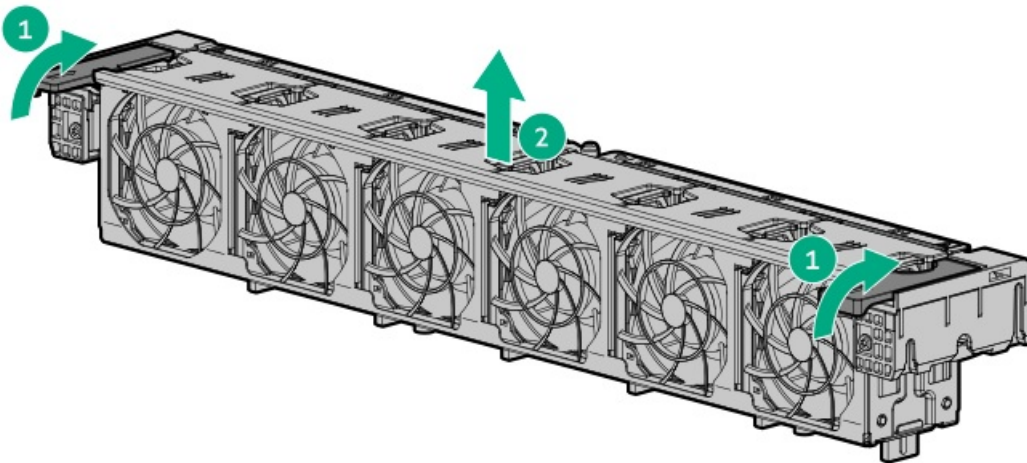

Installing the fan cage

⚠ CAUTION:

Do not operate the server for long periods with the access panel open or removed. Operating the server in this manner results in improper airflow and improper cooling that can lead to thermal damage.

i IMPORTANT: For optimum cooling, install fans in all primary fan locations.

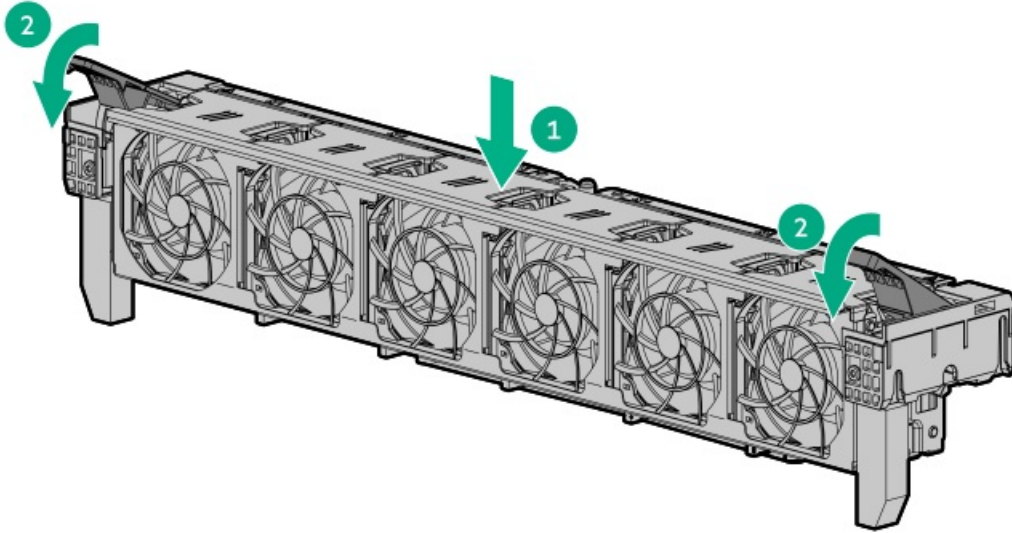

Removing the air baffle or midplane drive cage

CAUTION: Do not detach the cable that connects the battery pack to the cache module. Detaching the cable causes any unsaved data in the cache module to be lost.

CAUTION: For proper cooling, do not operate the server without the access panel, baffles, expansion slot covers, or blanks installed. If the server supports hot-plug components, minimize the amount of time the access panel is open.

Procedure

1. Power down the server.
2. Remove all power:
 - a. Disconnect each power cord from the power source.
 - b. Disconnect each power cord from the server.
3. Do one of the following:
 - Extend the server from the rack.
 - Remove the server from the rack.
4. Remove the access panel.
5. Do one of the following:
 - Remove the air baffle.

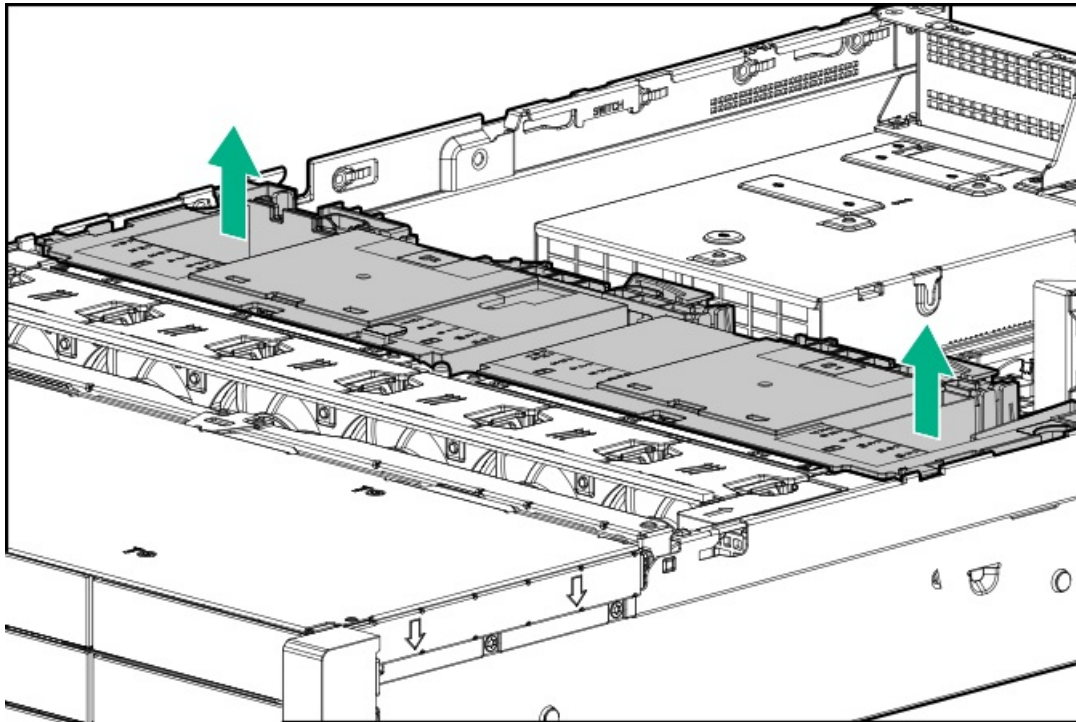

- Remove the midplane drive cage:
 - a. Disconnect all cables.
 - b. Remove all drives.
Be sure to note the location of each drive.
 - c. Remove the drive cage.
A 4LFF version is shown.

CAUTION: Do not drop the drive cage on the system board. Dropping the drive cage on the system board might damage the system or components. Remove all drives and use two hands when installing or removing the drive cage.

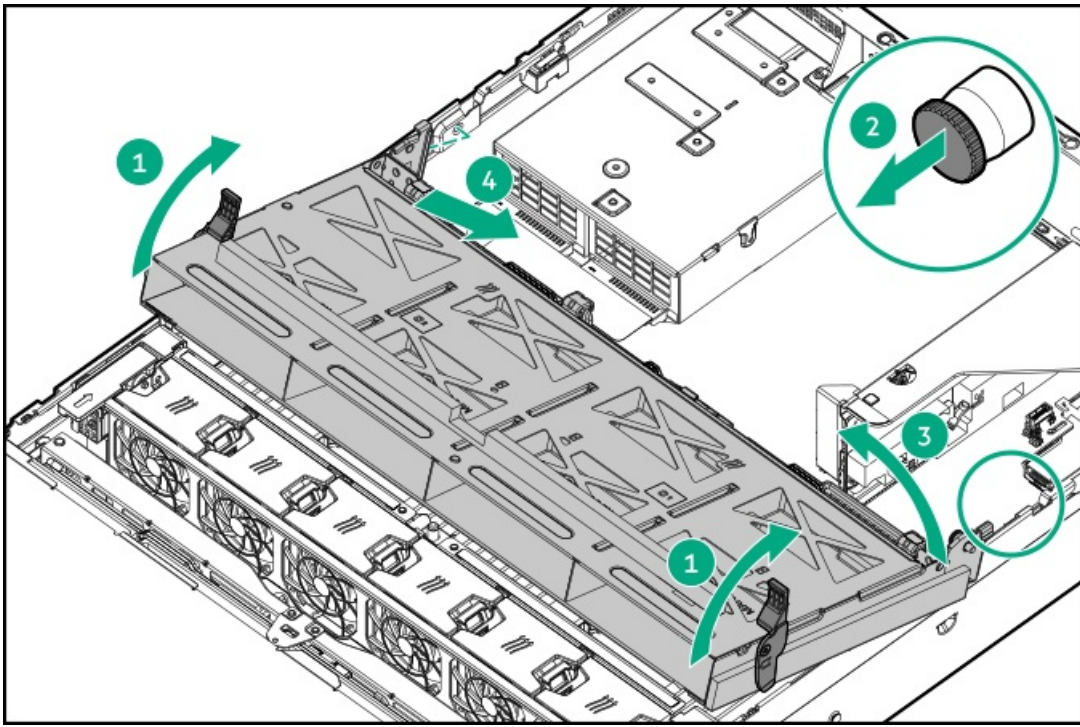

Installing the air baffle

Procedure

1. Observe the following alerts.

⚠ **CAUTION:** For proper cooling, do not operate the server without the access panel, baffles, expansion slot covers, or blanks installed. If the server supports hot-plug components, minimize the amount of time the access panel is open.

⚠ **CAUTION:** Do not detach the cable that connects the battery pack to the cache module. Detaching the cable causes any unsaved data in the cache module to be lost.

2. Install the air baffle.

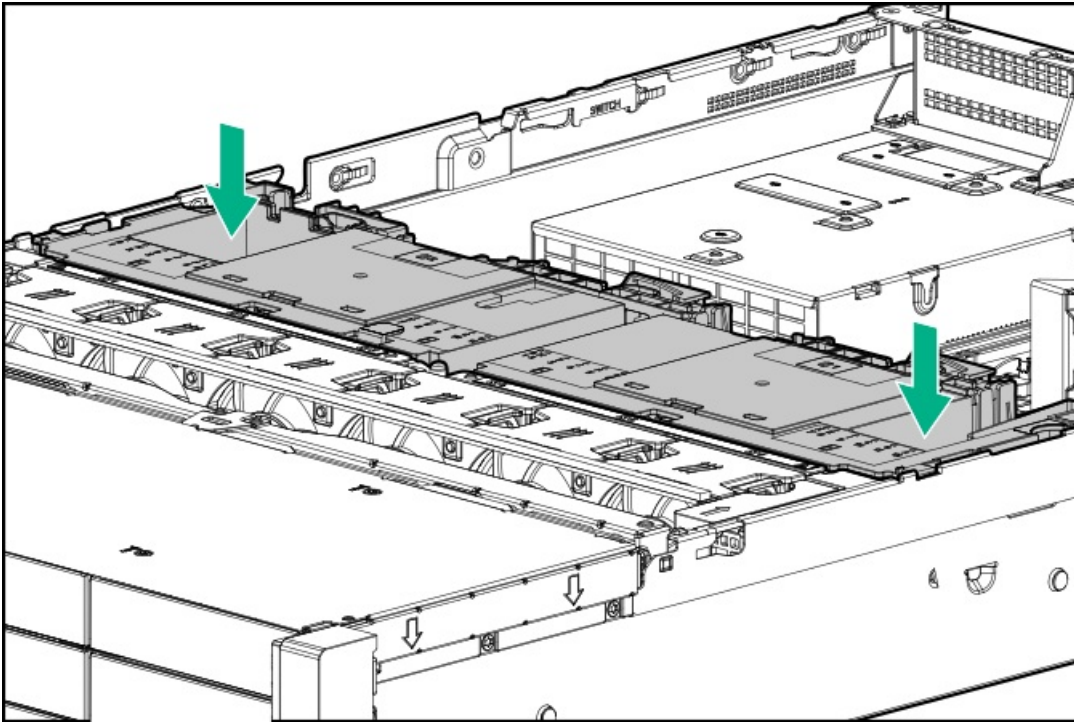

Removing a riser cage

CAUTION: To prevent damage to the server or expansion boards, power down the server and remove all AC power cords before removing or installing the PCI riser cage.

Procedure

1. Power down the server.
2. Remove all power:
 - a. Disconnect each power cord from the power source.
 - b. Disconnect each power cord from the server.
3. Do one of the following:
 - Extend the server from the rack.
 - Remove the server from the rack.
4. Remove the access panel.
5. Remove the riser cage:
 - Primary and secondary riser cages

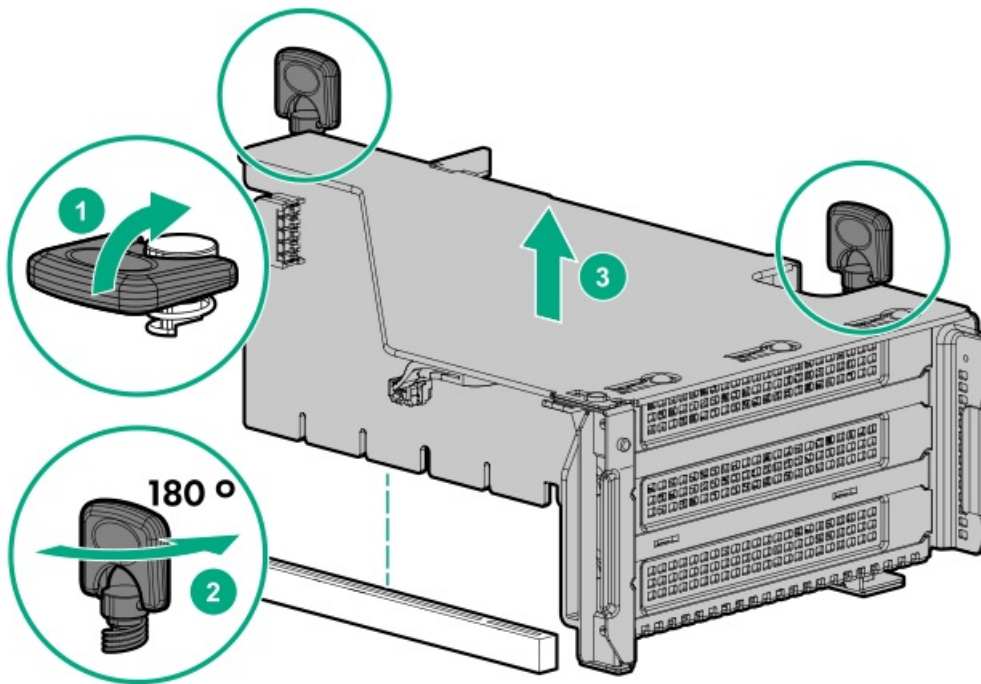

- Tertiary riser cage

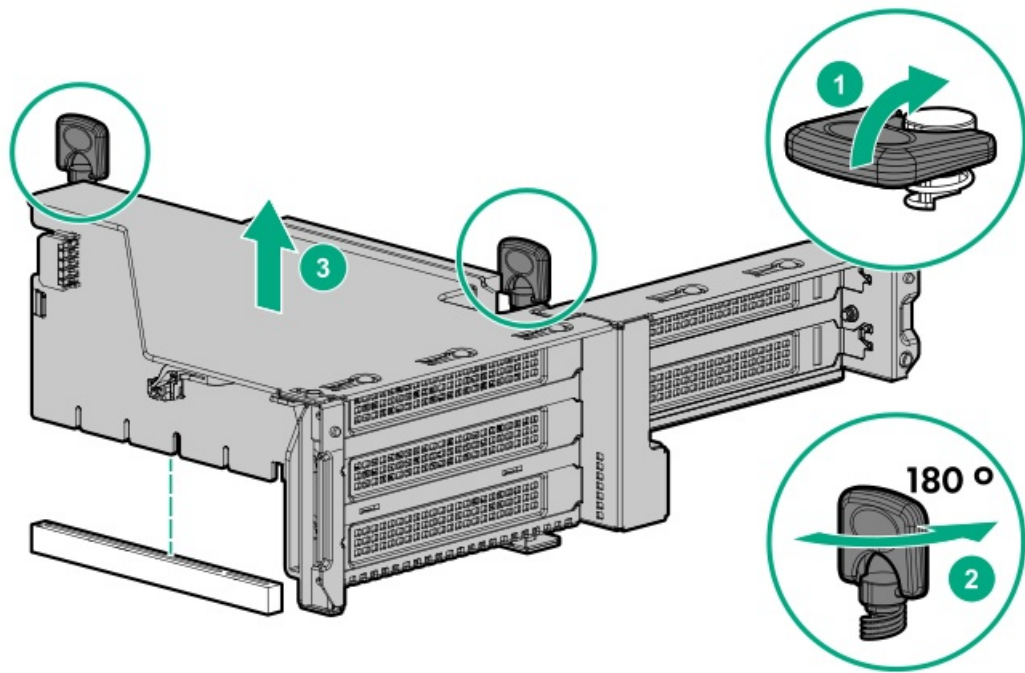

Removing a riser slot blank

CAUTION: To prevent improper cooling or thermal damage, the server PCI slots must have an expansion slot blank or an expansion board installed.

Procedure

1. Power down the server.
2. Remove all power:
 - a. Disconnect each power cord from the power source.
 - b. Disconnect each power cord from the server.
3. Do one of the following:
 - Extend the server from the rack.
 - Remove the server from the rack.
4. Remove the access panel.
5. Remove the riser cage.
6. Remove the blank.

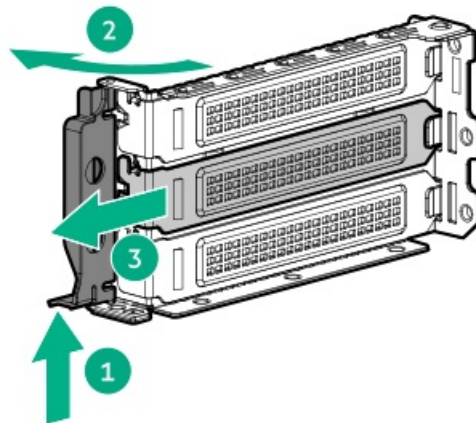

Removing the hard drive blank

CAUTION: To prevent improper cooling and thermal damage, do not operate the server unless all bays are populated with either a component or a blank.

Figure 1: Removing an SFF drive blank

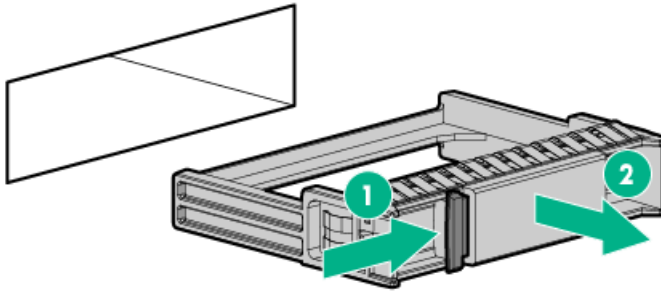
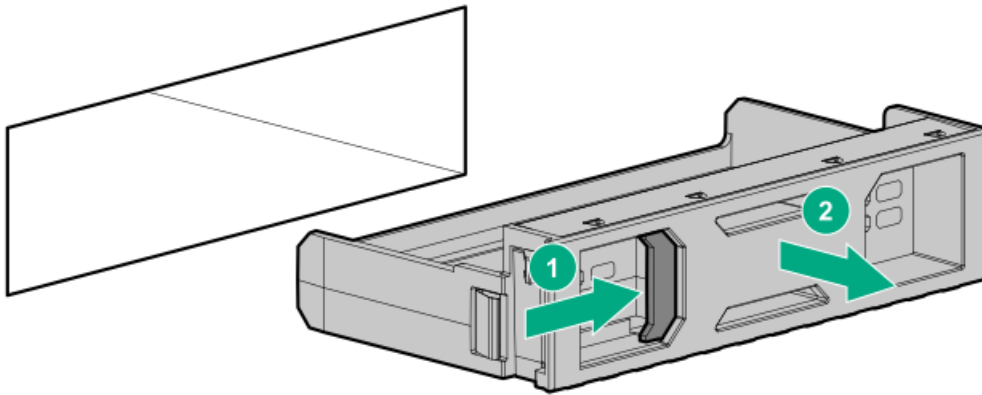

Figure 2: Removing an LFF drive blank



To replace the component, reverse the removal procedure.

Releasing the cable management arm

Release the cable management arm and then swing the arm away from the rack.

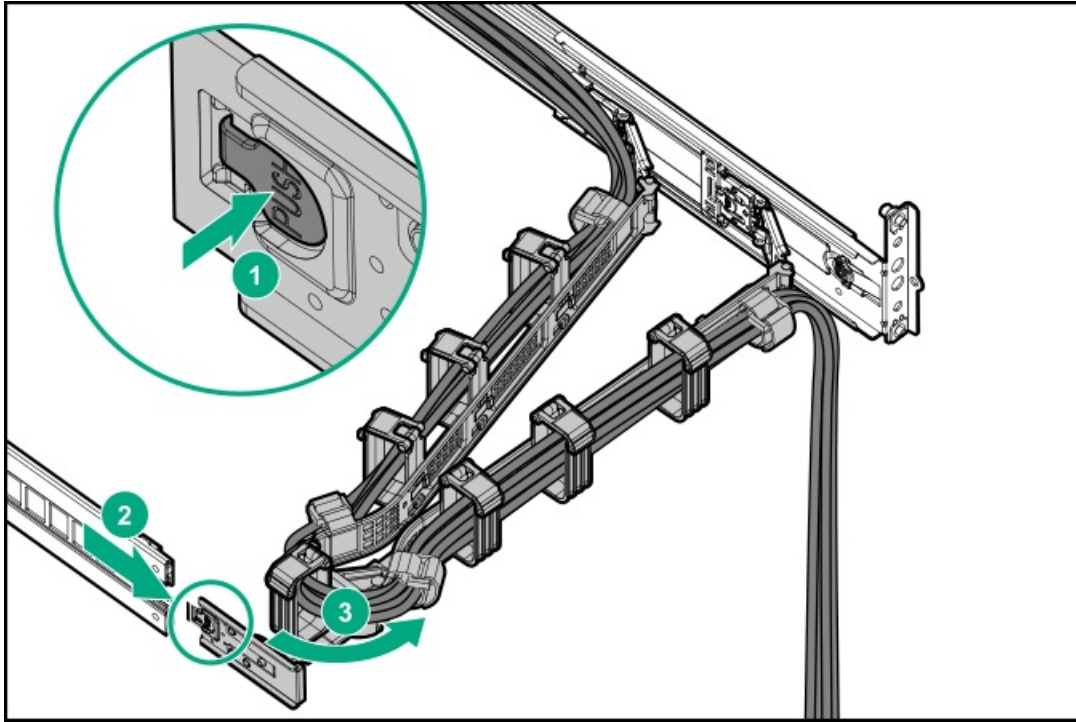

Accessing the Systems Insight Display

The Systems Insight Display is supported only on SFF models.

Procedure

1. Press and release the panel.
2. After the display fully ejects, rotate the display to view the LEDs.

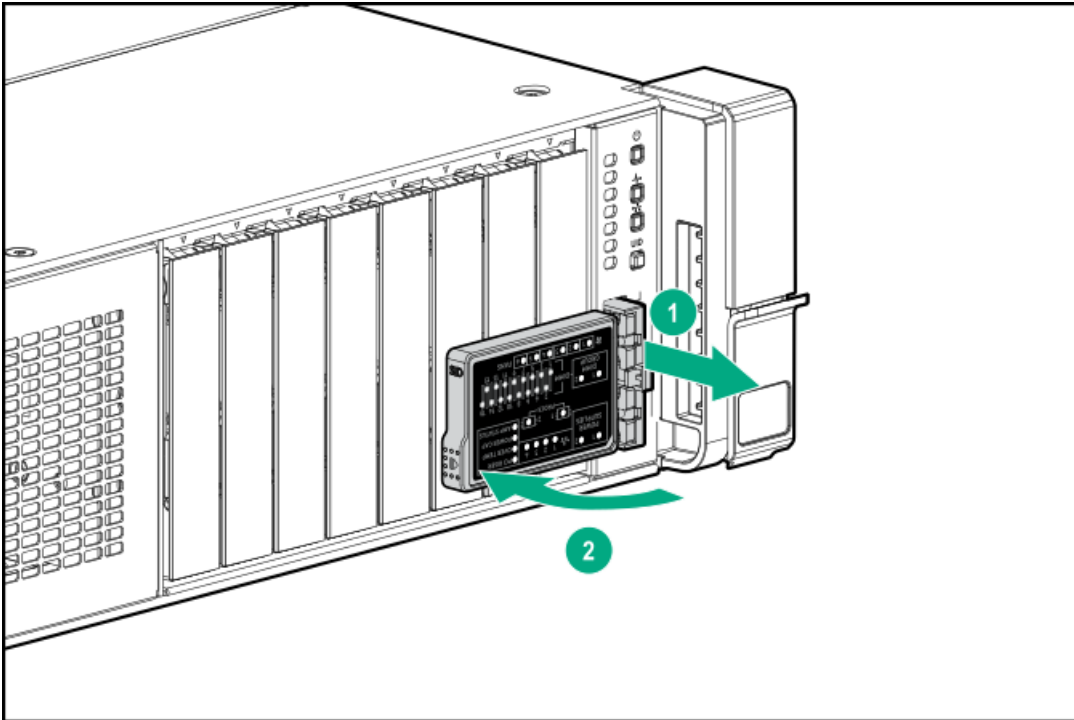

Optional services

Delivered by experienced, certified engineers, HPE support services help you keep your servers up and running with support packages tailored specifically for HPE ProLiant systems. HPE support services let you integrate both hardware and software support into a single package. A number of service level options are available to meet your business and IT needs.

HPE support services offer upgraded service levels to expand the standard product warranty with easy-to-buy, easy-to-use support packages that will help you make the most of your server investments. Some of the HPE support services for hardware, software, or both are:

- Foundation Care – Keep systems running.

The time commitment for this service might vary depending on the site's geographical region. For more service information available at your site, contact your local [HPE support center](#).

- Deployment service for both hardware and software.
- HPE Education Services – Help train your IT staff.

For more information on HPE support services, see the HPE Pointnext website:

<https://www.hpe.com/services>



Set up the server

Prerequisites

Before setting up the server:

- Download the latest SPP:
<http://www.hpe.com/servers/spp/download>
Support validation required
- Verify that your OS or virtualization software is supported:
<http://www.hpe.com/info/ossupport>
- Read the operational requirements for the server:
[Operational requirements](#)
- Read the safety and compliance information on the HPE website:
<http://www.hpe.com/support/safety-compliance-enterpriseproducts>
- Obtain the storage driver if needed:
 - Download it from the HPE support center website.
 - Extract it from the SPP.

Procedure

Unbox the server

1. Unbox the server and verify the contents:

- A server
- A power cord
- Rack-mounting hardware
- Documentation

2. (Optional) Install hardware options.

For installation instructions, see "Hardware options installation."

Rack the server

3. Install the server in a rack.

The racking procedures are included with the rack rails.

- a. Connect devices, cables, and cords to the server.
- b. [Secure cables using the cable management arm.](#)

4. Decide how to manage the server:

- Locally: use a KVM switch or a connect a keyboard, monitor, and mouse.
- Remotely: connect to the iLO web interface and run a remote console:
 - a. Verify the following:
 - iLO is licensed to use the remote console feature.
If iLO is not licensed, visit <https://www.hpe.com/info/ilo>
 - The iLO management port is connected to a secure network.
 - b. Using a browser, navigate to the iLO web interface, and then log in.

```
https://<iLO hostname or IP address>
```

Note the following:

- The hostname is located on the serial pull tab.
- If a DHCP server assigns the IP address, the IP address appears on the boot screen.
- If a static IP address is assigned, use that IP address.

- o The default login credentials are located on the serial label pull tab.
- c. In the side navigation, click the Remote Console & Media link, and then launch a remote console.

Power on the server

5. Press the Power On/Standby button.

For remote management, use the iLO virtual power button.

Update the firmware

6. Using the SPP, update the following:

- System ROM
- Storage controller
- Network adapters
- Intelligent Provisioning

Set up storage

7. Do one of the following:

- To configure the server to boot from a SAN, see the following guide:
<https://www.hpe.com/info/boot-from-san-config-guide>
- If a smart array controller is installed:
 - o For SR controllers, use HPE Smart Storage Administrator to create arrays:
 - a. From the boot screen, press F10 to run Intelligent Provisioning.
 - b. From Intelligent Provisioning, run [HPE Smart Storage Administrator](#).
 - o For MR controllers, use the UEFI System Configuration to create arrays.

 **IMPORTANT:**

MR controllers are not supported by Intelligent Provisioning or Smart Storage Administrator.

 **NOTE:**

Before installing an OS with a MR controller, configure the drives. If the drives are not configured, the OS will not detect the drives during installation. For more information, see the MR user guide for your controller.

- If no controller is installed, do one of the following:
 - o AHCI is enabled by default. You can deploy an OS or virtualization software.
 - o Disable AHCI, enable software RAID, and then create an array:
 - a. From the boot screen, press F9 to run UEFI System Utilities.
 - b. From the UEFI System Utilities screen, select System Configurations > BIOS/Platform Configuration (RBSU) > Storage Options > SATA Controller Options > Embedded SATA configuration > SmartRAID SW RAID Support
 - c. Enable SW RAID.
 - d. Save the configuration and reboot the server.
 - e. Create an array:
 - i. From the boot screen, press F9 to run UEFI System Utilities.
 - ii. From the UEFI System Utilities screen, select System Configuration > EmbeddedStorage: HPE SR100i Gen10+ SW RAID > Array Configuration > Create Array

Deploy an OS or virtualization software

8. Do one of the following:

- Run Intelligent Provisioning to deploy an OS.

Press F10 at the boot screen to run Intelligent Provisioning.

i IMPORTANT:

Smart array MR controllers are not supported by Intelligent Provisioning or Smart Storage Administrator.

- Manually deploy an OS.
 - a. Insert the installation media.

For remote management, click **Virtual Drives** in the iLO remote console to mount images, drivers, or files to a virtual folder. If a storage driver is required to install the OS, use the virtual folder to store the driver.
 - b. Press **F11** at the boot screen to select the boot device.
 - c. After the OS is installed, [update the drivers](#).
- 9. Register the server (<http://www.hpe.com/info/register>).

Space and airflow requirements

To allow for servicing and adequate airflow, observe the following space and airflow requirements when deciding where to install a rack:

- Leave a minimum clearance of 63.5 cm (25 in) in front of the rack.
- Leave a minimum clearance of 76.2 cm (30 in) behind the rack.
- Leave a minimum clearance of 121.9 cm (48 in) from the back of the rack to the back of another rack or row of racks.

Hewlett Packard Enterprise servers draw in cool air through the front door and expel warm air through the rear door. Therefore, the front and rear rack doors must be adequately ventilated to allow ambient room air to enter the cabinet, and the rear door must be adequately ventilated to allow the warm air to escape from the cabinet.

△ CAUTION: To prevent improper cooling and damage to the equipment, do not block the ventilation openings.

When vertical space in the rack is not filled by a server or rack component, the gaps between the components cause changes in airflow through the rack and across the servers. Cover all gaps with blanking panels to maintain proper airflow.

△ CAUTION: Always use blanking panels to fill empty vertical spaces in the rack. This arrangement ensures proper airflow. Using a rack without blanking panels results in improper cooling that can lead to thermal damage.

The 9000 and 10000 Series Racks provide proper server cooling from flow-through perforations in the front and rear doors that provide 64 percent open area for ventilation.

△ CAUTION: When using a Compaq branded 7000 series rack, install the high airflow rack door insert (PN 327281-B21 for 42U rack, PN 157847-B21 for 22U rack) to provide proper front-to-back airflow and cooling.

△ CAUTION:

If a third-party rack is used, observe the following additional requirements to ensure adequate airflow and to prevent damage to the equipment:

- Front and rear doors—If the 42U rack includes closing front and rear doors, you must allow 5,350 sq cm (830 sq in) of holes evenly distributed from top to bottom to permit adequate airflow (equivalent to the required 64 percent open area for ventilation).
 - Side—The clearance between the installed rack component and the side panels of the rack must be a minimum of 7 cm (2.75 in).
-

Temperature requirements

To ensure continued safe and reliable equipment operation, install or position the system in a well-ventilated, climate-controlled environment.

The maximum recommended ambient operating temperature (TMRA) for most server products is 35°C (95°F). The temperature in the room where the rack is located must not exceed 35°C (95°F).

△ CAUTION: To reduce the risk of damage to the equipment when installing third-party options:

- Do not permit optional equipment to impede airflow around the server or to increase the internal rack temperature beyond the maximum allowable limits.
 - Do not exceed the manufacturer's TMRA.
-

Power requirements

Installation of this equipment must comply with local and regional electrical regulations governing the installation of information technology equipment by licensed electricians. This equipment is designed to operate in installations covered by NFPA 70, 1999 Edition (National Electric Code) and NFPA-75, 1992 (code for Protection of Electronic Computer/Data Processing Equipment). For electrical power ratings on options, refer to the product rating label or the user documentation supplied with that option.

WARNING: To reduce the risk of personal injury, fire, or damage to the equipment, do not overload the AC supply branch circuit that provides power to the rack. Consult the electrical authority having jurisdiction over wiring and installation requirements of your facility.

△ CAUTION: Protect the server from power fluctuations and temporary interruptions with a regulating uninterruptible power supply. This device protects the hardware from damage caused by power surges and voltage spikes and keeps the system in operation during a power failure.

Electrical grounding requirements

The server must be grounded properly for proper operation and safety. In the United States, you must install the equipment in accordance with NFPA 70, National Electric Code Article 250, as well as any local and regional building codes. In Canada, you must install the equipment in accordance with Canadian Standards Association, CSA C22.1, Canadian Electrical Code. In all other countries, you must install the equipment in accordance with any regional or national electrical wiring codes, such as the International Electrotechnical Commission (IEC) Code 364, parts 1 through 7. Furthermore, you must be sure that all power distribution devices used in the installation, such as branch wiring and receptacles, are listed or certified grounding-type devices.

Because of the high ground-leakage currents associated with multiple servers connected to the same power source, Hewlett Packard Enterprise recommends the use of a PDU that is either permanently wired to the building's branch circuit or includes a nondetachable cord that is wired to an industrial-style plug. NEMA locking-style plugs or those complying with IEC 60309 are considered suitable for this purpose. Using common power outlet strips for the server is not recommended.

Connecting a DC power cable to a DC power source

WARNING:

To reduce the risk of electric shock or energy hazards:

- This equipment must be installed by trained service personnel, as defined by the NEC and IEC 60950-1, Second Edition, the standard for Safety of Information Technology Equipment.
- Connect the equipment to a reliably grounded Secondary circuit source. A Secondary circuit has no direct connection to a Primary circuit and derives its power from a transformer, converter, or equivalent isolation device.
- The branch circuit overcurrent protection must be rated 27 A.

WARNING: When installing a DC power supply, the ground wire must be connected before the positive or negative leads.

WARNING: Remove power from the power supply before performing any installation steps or maintenance on the power supply.

⚠ CAUTION: The server equipment connects the earthed conductor of the DC supply circuit to the earthing conductor at the equipment. For more information, see the documentation that ships with the power supply.

-
- ⚠ CAUTION:** If the DC connection exists between the earthed conductor of the DC supply circuit and the earthing conductor at the server equipment, the following conditions must be met:
- This equipment must be connected directly to the DC supply system earthing electrode conductor or to a bonding jumper from an earthing terminal bar or bus to which the DC supply system earthing electrode conductor is connected.
 - This equipment should be located in the same immediate area (such as adjacent cabinets) as any other equipment that has a connection between the earthed conductor of the same DC supply circuit and the earthing conductor, and also the point of earthing of the DC system. The DC system should be earthed elsewhere.
 - The DC supply source is to be located within the same premises as the equipment.
 - Switching or disconnecting devices should not be in the earthed circuit conductor between the DC source and the point of connection of the earthing electrode conductor.
-

To connect a DC power cable to a DC power source:

1. Cut the DC power cord ends no shorter than 150 cm (59.06 in).
2. If the power source requires ring tongues, use a crimping tool to install the ring tongues on the power cord wires.

i IMPORTANT: The ring terminals must be UL approved and accommodate 12 gauge wires.

i IMPORTANT: The minimum nominal thread diameter of a pillar or stud type terminal must be 3.5 mm (0.138 in); the diameter of a screw type terminal must be 4.0 mm (0.157 in).

3. Stack each same-colored pair of wires and then attach them to the same power source. The power cord consists of three wires (black, red, and green).

For more information, see the documentation that ships with the power supply.

Server warnings and cautions

WARNING:

This server is heavy. To reduce the risk of personal injury or damage to the equipment:

- Observe local occupational health and safety requirements and guidelines for manual material handling.
 - Get help to lift and stabilize the product during installation or removal, especially when the product is not fastened to the rails. Hewlett Packard Enterprise recommends that a minimum of two people are required for all rack server installations. If the server is installed higher than chest level, a third person may be required to help align the server.
 - Use caution when installing the server in or removing the server from the rack; it is unstable when not fastened to the rails.
-

WARNING:

To reduce the risk of personal injury from hot surfaces, allow the drives and the internal system components to cool before touching them.

WARNING:

To reduce the risk of personal injury, electric shock, or damage to the equipment, remove the power cord to remove power from the server. The front panel Power On/Standby button does not completely shut off system power. Portions of the power supply and some internal circuitry remain active until AC/DC power is removed.

WARNING:

To reduce the risk of fire or burns after removing the energy pack:

- Do not disassemble, crush, or puncture the energy pack.
- Do not short external contacts.
- Do not dispose of the energy pack in fire or water.
- Do not expose the energy pack to low air pressure as it might lead to explosion or leakage of flammable liquid or gas.
- Do not expose the energy pack to temperatures higher than 60°C (140°F).

After power is disconnected, battery voltage might still be present for 1s to 160s.

△ CAUTION:

Protect the server from power fluctuations and temporary interruptions with a regulating uninterruptible power supply. This device protects the hardware from damage caused by power surges and voltage spikes and keeps the system in operation during a power failure.

△ CAUTION:

Do not operate the server for long periods with the access panel open or removed. Operating the server in this manner results in improper airflow and improper cooling that can lead to thermal damage.

Rack warnings

WARNING: To reduce the risk of personal injury or damage to the equipment, be sure that:

- The leveling jacks are extended to the floor.
 - The full weight of the rack rests on the leveling jacks.
 - The stabilizing feet are attached to the rack if it is a single-rack installation.
 - The racks are coupled together in multiple-rack installations.
 - Only one component is extended at a time. A rack may become unstable if more than one component is extended for any reason.
-
-

WARNING: To reduce the risk of personal injury or equipment damage when unloading a rack:

- At least two people are needed to safely unload the rack from the pallet. An empty 42U rack can weigh as much as 115 kg (253 lb), can stand more than 2.1 m (7 ft) tall, and might become unstable when being moved on its casters.
 - Never stand in front of the rack when it is rolling down the ramp from the pallet. Always handle the rack from both sides.
-
-

WARNING:

To reduce the risk of personal injury or damage to the equipment, adequately stabilize the rack before extending a component outside the rack. Extend only one component at a time. A rack may become unstable if more than one component is extended.

WARNING:

When installing a server in a telco rack, be sure that the rack frame is adequately secured at the top and bottom to the building structure.

Electrostatic discharge

Be aware of the precautions you must follow when setting up the system or handling components. A discharge of static electricity from a finger or other conductor may damage system boards or other static-sensitive devices. This type of damage may reduce the life expectancy of the system or component.

To prevent electrostatic damage:

- Avoid hand contact by transporting and storing products in static-safe containers.
- Keep electrostatic-sensitive parts in their containers until they arrive at static-free workstations.
- Place parts on a grounded surface before removing them from their containers.
- Avoid touching pins, leads, or circuitry.
- Always be properly grounded when touching a static-sensitive component or assembly. Use one or more of the following methods when handling or installing electrostatic-sensitive parts:
 - Use a wrist strap connected by a ground cord to a grounded workstation or computer chassis. Wrist straps are flexible straps with a minimum of 1 megohm \pm 10 percent resistance in the ground cords. To provide proper ground, wear the strap snug against the skin.
 - Use heel straps, toe straps, or boot straps at standing workstations. Wear the straps on both feet when standing on conductive floors or dissipating floor mats.
 - Use conductive field service tools.
 - Use a portable field service kit with a folding static-dissipating work mat.

If you do not have any of the suggested equipment for proper grounding, have an authorized reseller install the part.

For more information on static electricity or assistance with product installation, contact an authorized reseller.



Server box contents

The server shipping box contains the following contents:

- A server
- A power cord
- Rack-mounting hardware (optional)
- Documentation



Installing hardware options

Install any hardware options before initializing the server. For options installation information, refer to the option documentation. For server-specific information, refer to "[Hardware options installation](#)."

POST screen options

When the server is powered on, the POST screen is displayed. The following options are displayed:

- System Utilities (F9)
Use this option to configure the system BIOS.
- Intelligent Provisioning (F10)
Use this option to deploy an operating system or configure storage.
- Boot order (F11)
Use this option to make a one-time boot selection.
- Network boot (F12)
Use this option to boot the server from the network.

Installing or deploying an operating system

Before installing an operating system, observe the following:

- Be sure to read the HPE UEFI requirements for ProLiant servers on the [Hewlett Packard Enterprise website](#). If UEFI requirements are not met, you might experience boot failures or other errors when installing the operating system.
- Update firmware before using the server for the first time, unless software or components require an older version. For more information, see [Keeping the system current](#).
- For the latest information on supported operating systems, see the [Hewlett Packard Enterprise website](#).
- The server does not ship with OS media. All system software and firmware is preloaded on the server.

Registering the server

To experience quicker service and more efficient support, register the product at the [Hewlett Packard Enterprise Product Registration website](#).





Product QuickSpecs

For more information about product features, specifications, options, configurations, and compatibility, see the product QuickSpecs on the Hewlett Packard Enterprise website (<https://www.hpe.com/info/qs>).



Introduction

Install any hardware options before initializing the server. If multiple options are being installed, read the installation instructions for all the hardware options to identify similar steps and streamline the installation process.

WARNING: To reduce the risk of personal injury from hot surfaces, allow the drives and the internal system components to cool before touching them.

△ CAUTION: To prevent damage to electrical components, properly ground the server before beginning any installation procedure. Improper grounding can cause electrostatic discharge.

Installing a fan filter into the security bezel

The fan filter installs into the security bezel. To add a fan filter, the server must have a security bezel.

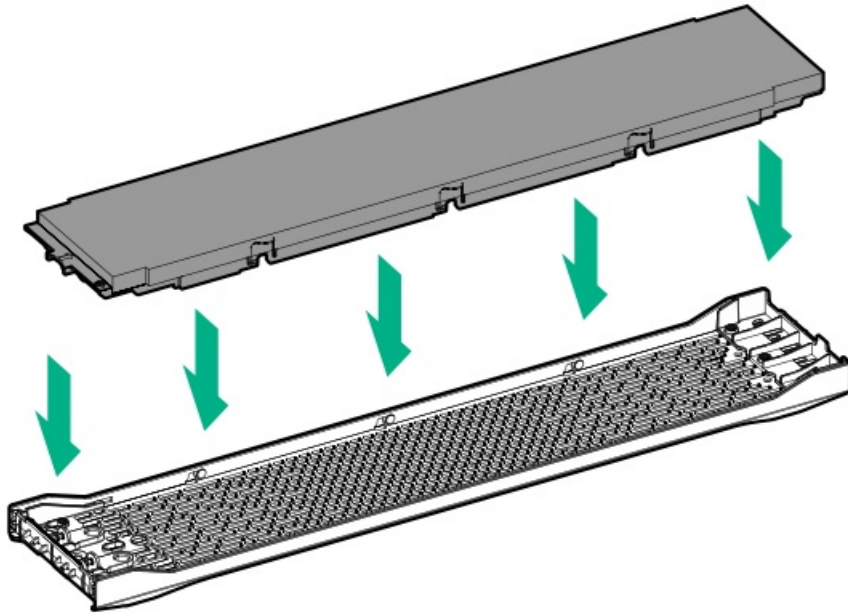

Installing the bezel and bezel lock

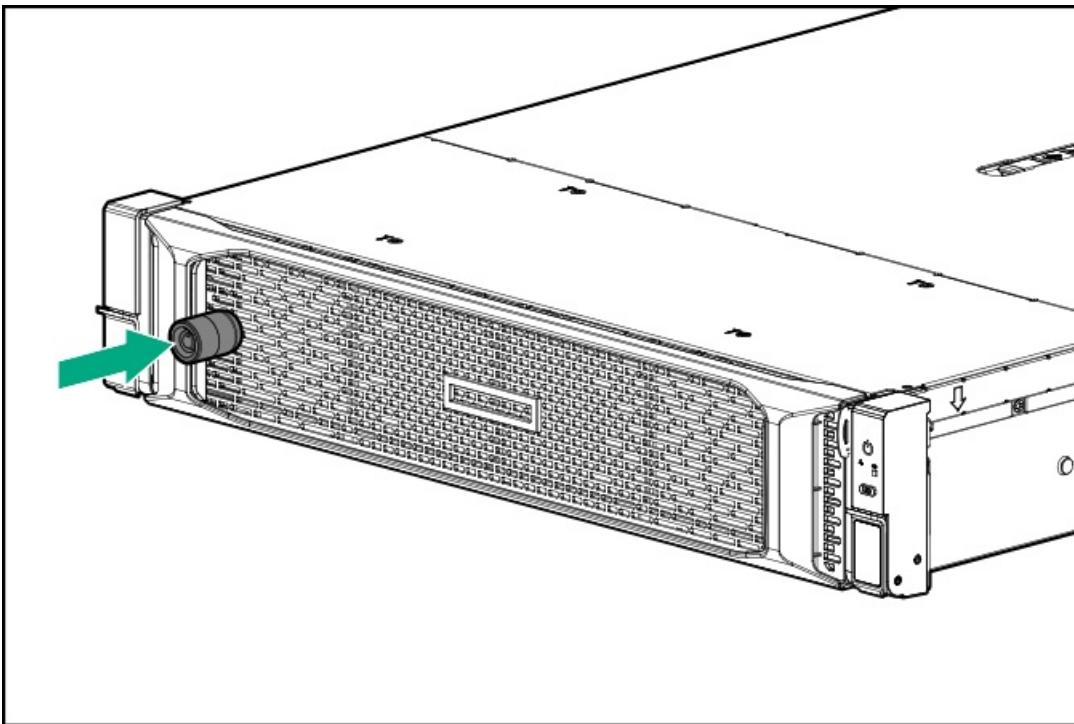
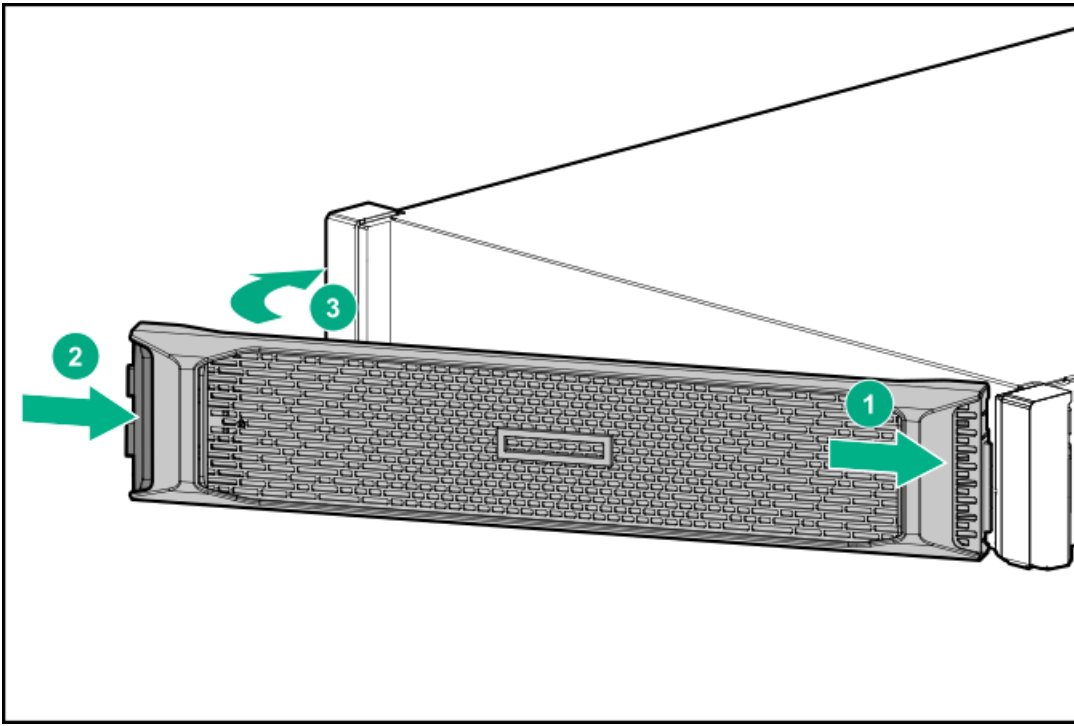

Power supply options



Hot-plug power supply calculations

For hot-plug power supply specifications and calculators to determine electrical and heat loading for the server, see the Hewlett Packard Enterprise Power Advisor website (<https://www.hpe.com/info/poweradvisor/online>).

Installing a redundant hot-plug power supply

⚠ CAUTION:

All power supplies installed in the server must have the same output power capacity. Verify that all power supplies have the same part number and label color. The system becomes unstable and might shut down if it detects different power supplies.

⚠ CAUTION:

To prevent improper cooling and thermal damage, do not operate the server unless all bays are populated with either a component or a blank.

Procedure

1. Release the cable management arm to access the rear panel.
2. Remove the blank.

WARNING:

To reduce the risk of personal injury from hot surfaces, allow the power supply or power supply blank to cool before touching it.

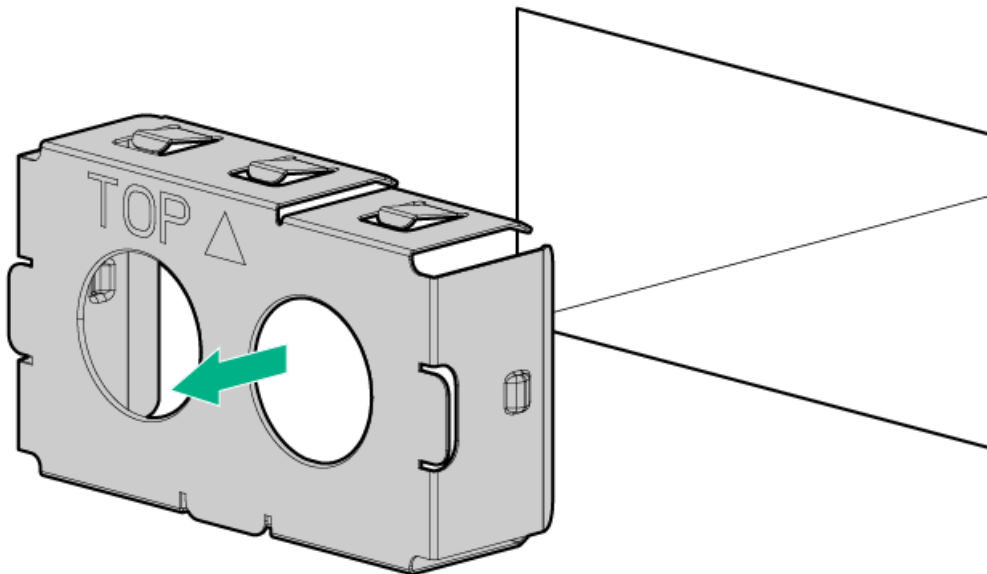

3. Insert the power supply into the power supply bay until it clicks into place.

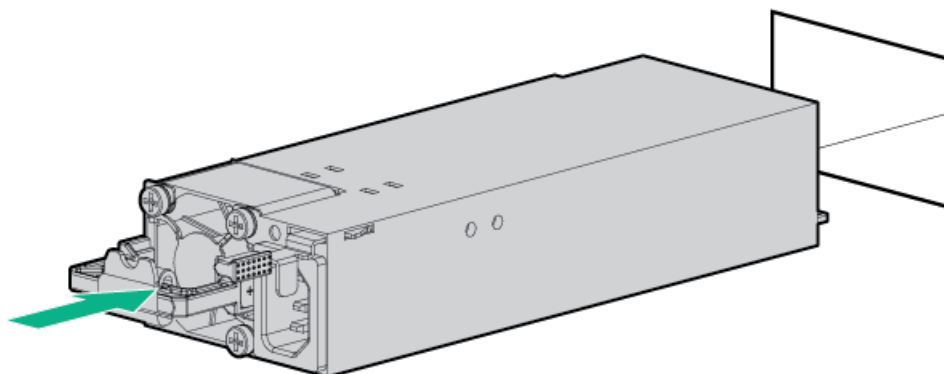

4. Connect the power cord to the power supply.

5. Secure the power cord in the strain relief strap attached to the power supply handle:

a. Unwrap the strain relief strap from the power supply handle.

△ CAUTION: Avoid tight bend radii to prevent damaging the internal wires of a power cord or a server cable. Never bend power cords and server cables tight enough to cause a crease in the sheathing.

b. Secure the power cord with the strain relief strap.

Roll the extra length of the strap around the power supply handle.

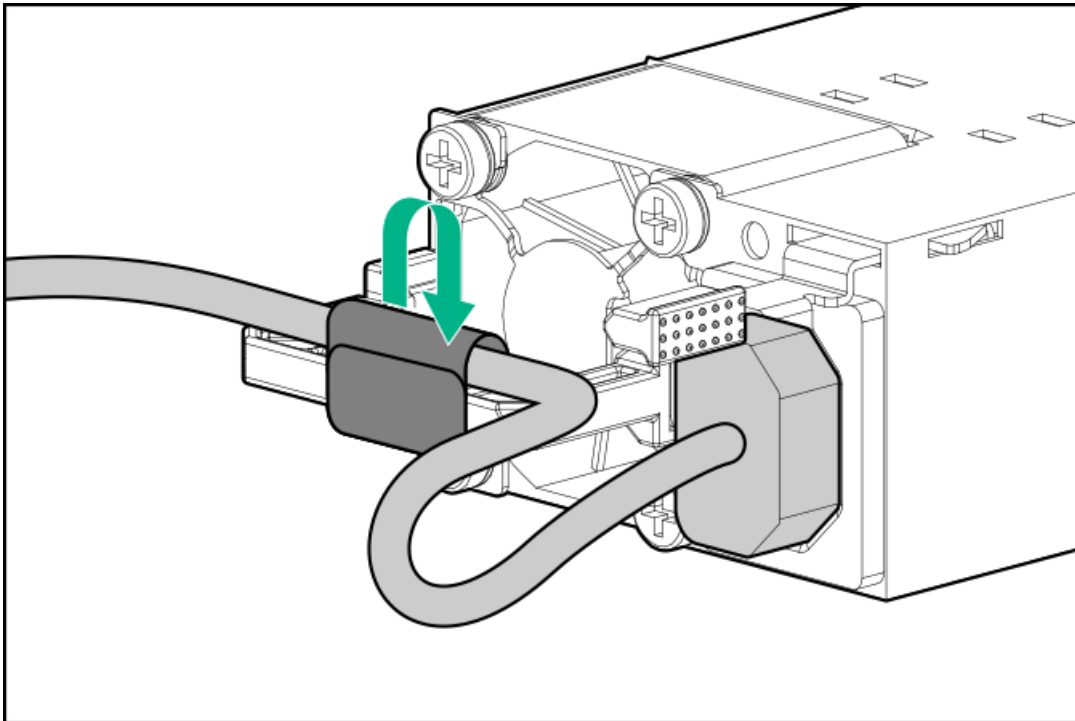

6. Connect the power cord to the power source.

7. Observe the power supply LED.

Installing the HPE 800 W Flex Slot -48 VDC hot-plug power supply

The DC power supply option kits do not ship with a Power Supply DC cable Kit and may not include a Power Supply Cable Lug kit. The optional DC Cable kit or the optional DC Cable Lug Kit may be purchased directly from Hewlett Packard Enterprise or an authorized HPE reseller. For additional information, refer to the power supply QuickSpecs at <https://www.hpe.com/info/fsps-qs>.

WARNING:

To reduce the risk of electric shock, fire, and damage to the equipment, you must install this product in accordance with the following guidelines:

- The HPE 800 W Flex Slot -48 VDC hot-plug power supply is intended only for installation in Hewlett Packard Enterprise servers located in a restricted access location.
- The HPE 800 W Flex Slot -48 VDC hot-plug power supply is not intended for direct connection to the DC supply branch circuit. Only connect this power supply to a power distribution unit (PDU) that provides an independent overcurrent-protected output for each DC power supply. Each output overcurrent-protected device in the PDU must be suitable for interrupting fault current available from the DC power source and must be rated no more than 30 A.
- The PDU output must have a shut-off switch or a circuit breaker to disconnect power for each power supply. To completely remove power from the power supply, disconnect power at the PDU. Disconnect the power for each power supply, if there are multiple power supplies.
- In accordance with applicable national requirements for Information Technology Equipment and Telecommunications Equipment, this power supply only connects to DC power sources that are classified as SELV or TNV. Generally, these requirements are based on the International Standard for Information Technology Equipment, IEC 60950-1/IEC 62368-1. In accordance with local and regional electric codes and regulations, the DC source must have one pole (Neutral/Return) reliably connected to earth ground.
- You must connect the power supply ground screw located on the front of the power supply to a suitable ground (earth) terminal. In accordance with local and regional electric codes and regulations, this terminal must be connected to a suitable building ground (earth) terminal. Do not rely on the rack or cabinet chassis to provide adequate ground (earth) continuity.

Prerequisites

Before you install this option, make sure that you have the following items available:

- No. 1 Phillips screwdriver
- Optional Q0H80A HPE 800W DC Power Cable Kit can be purchased from an HPE authorized reseller.
- If you are not using an input power cord option, the power supply cabling must be made in consultation with a licensed electrician and be compliant with local code.
- If you are replacing the factory installed ground lug, use the KST RNB5-5 crimp terminal ring or equivalent. Use an M5-0.80 x 8 screw to attach the ground lug to the power supply.

Procedure

1. Remove the power supply blank.

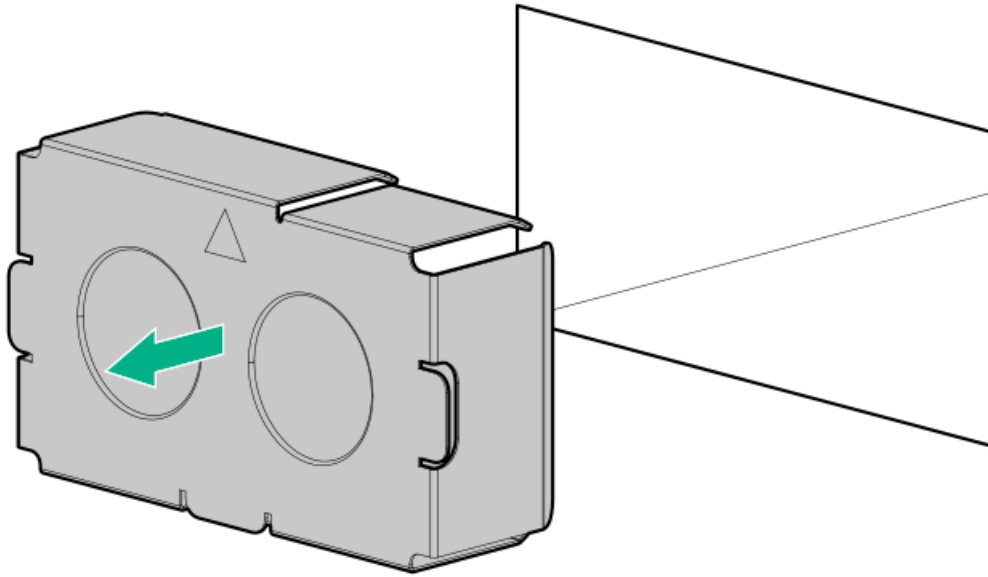

2. Remove the ring tongue.

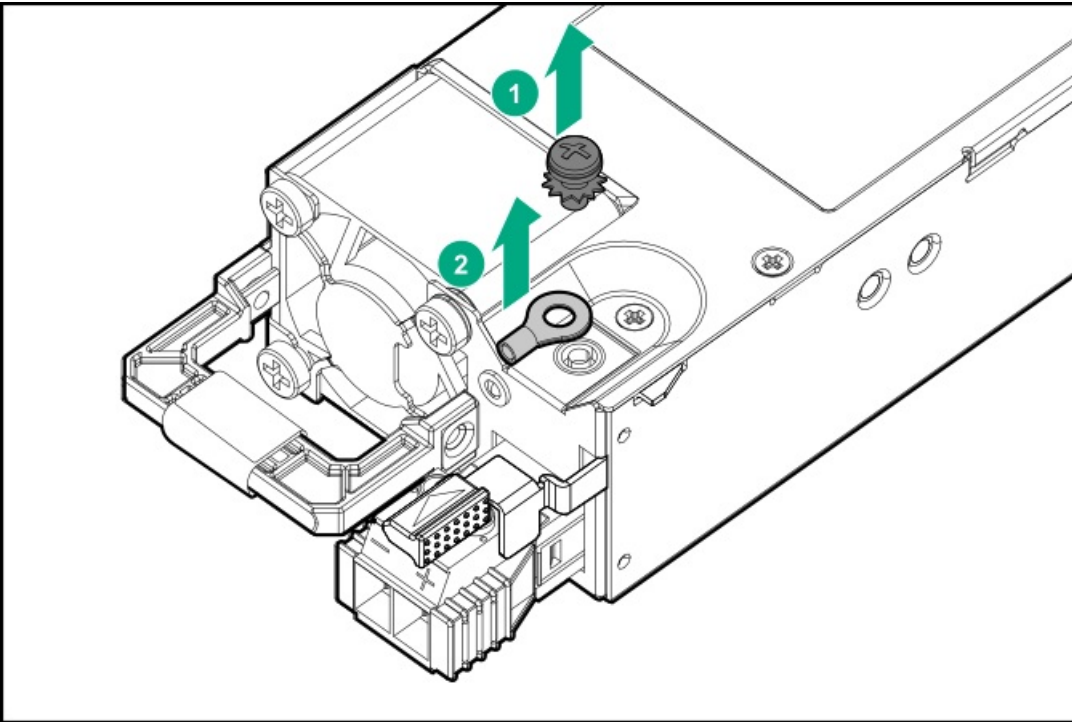

3. Crimp the ring tongue to the ground cable from the -48 V DC power source.



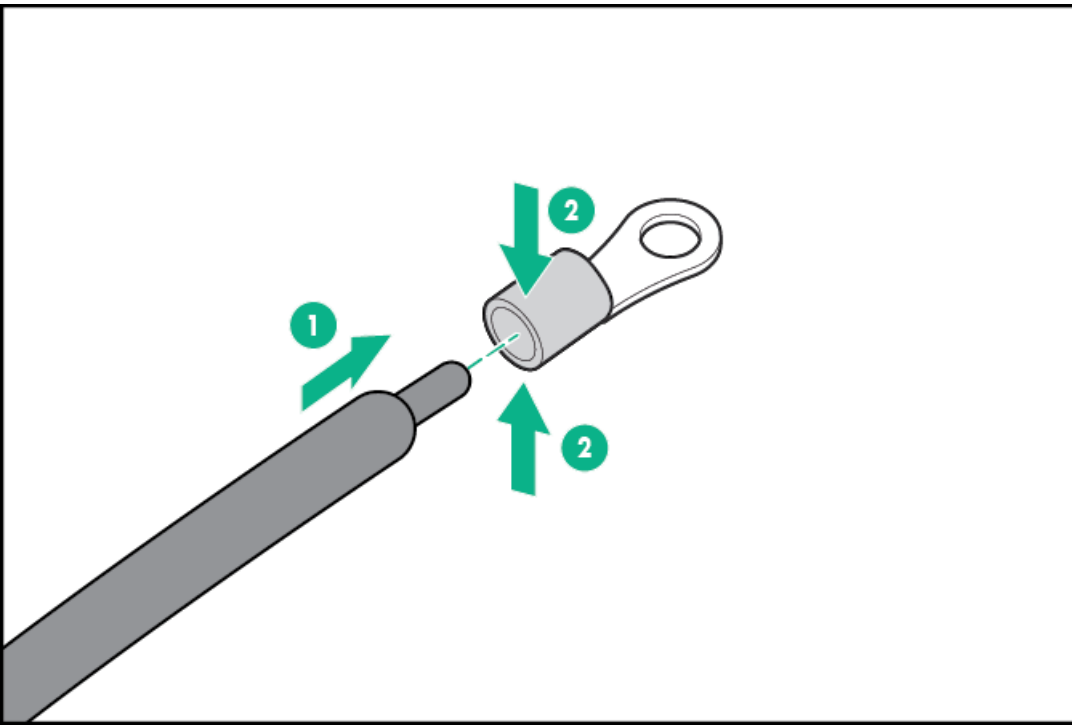

4. Remove the terminal block connector.

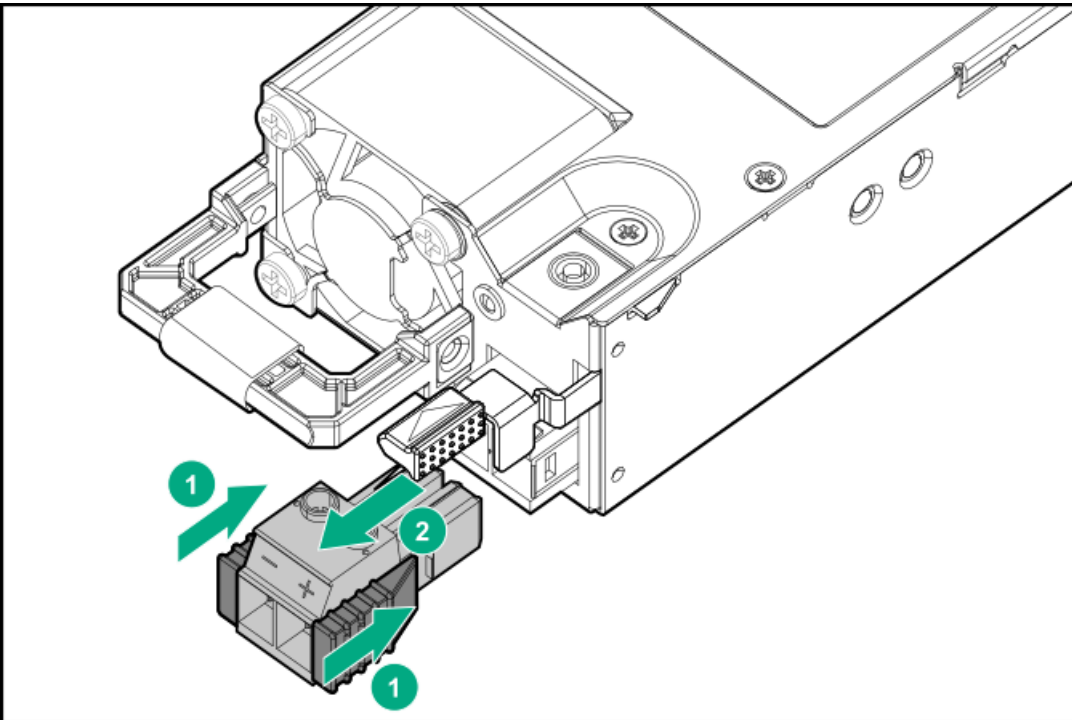

5. Loosen the screws on the terminal block connector.

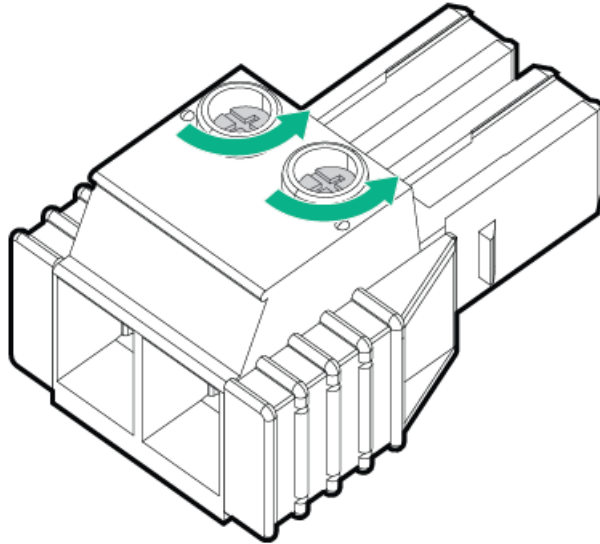

6. Attach the ground (earthed) wire to the ground screw and washer and tighten to 1.47 N m (13 lb-in) of torque. The ground wire must be connected before the -48 V wire and the return wire.

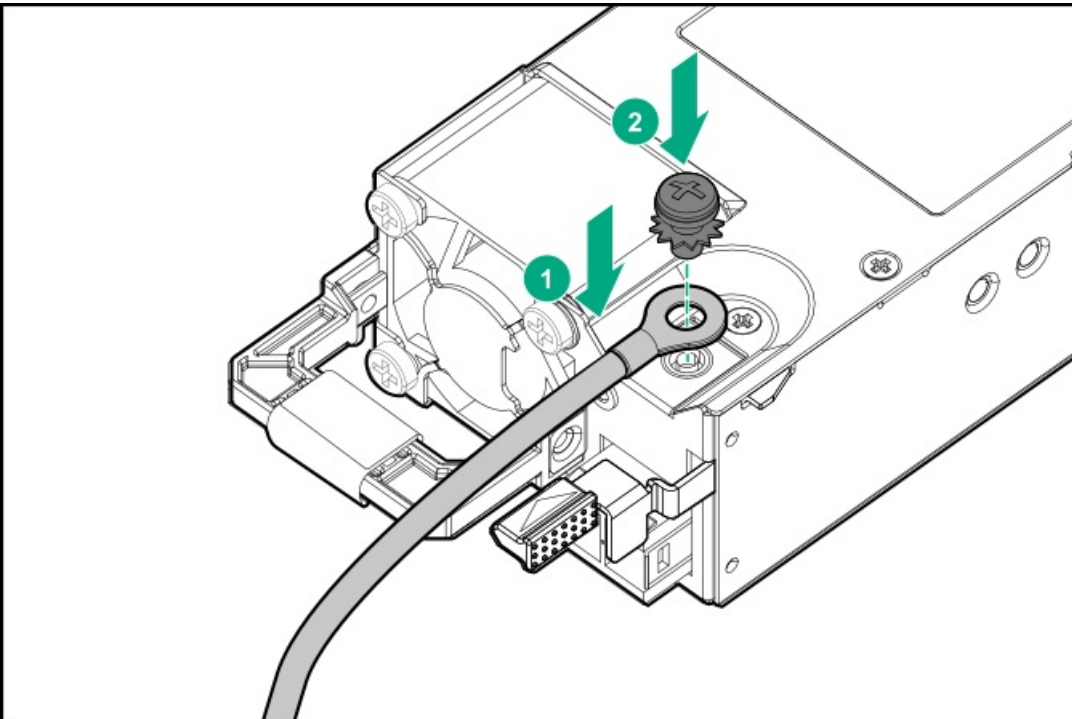

7. Insert the -48 V wire into the left side of the terminal block connector, and then tighten the screw to 1.3 N m (10 lb-in) of torque.

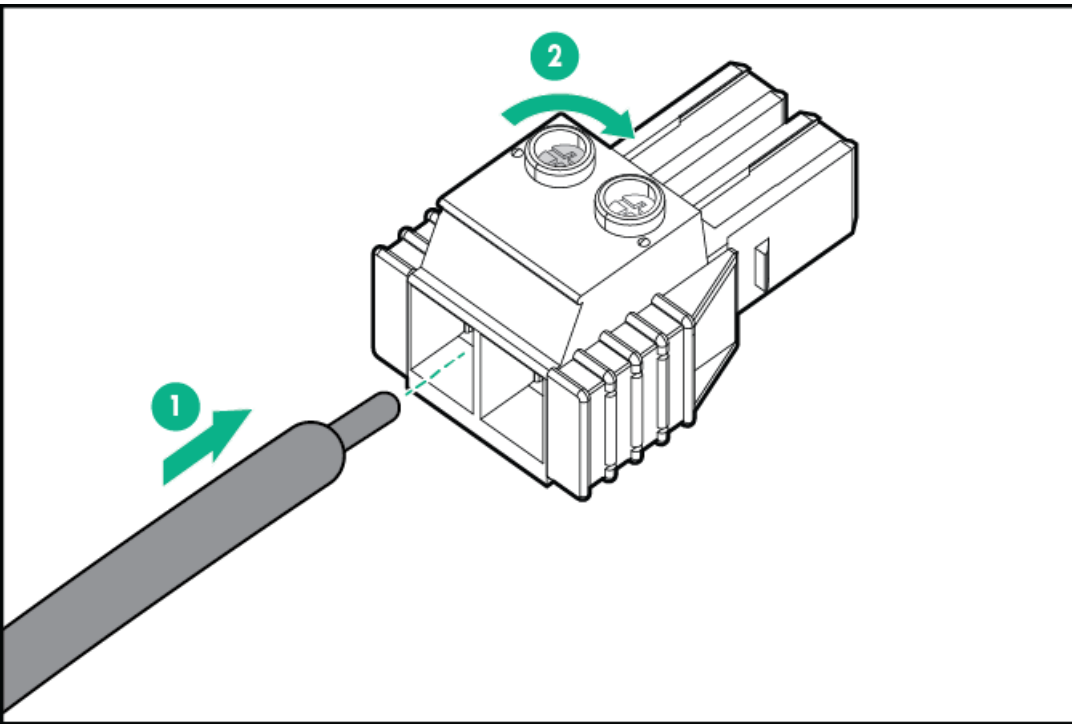

8. Insert the return wire into the right side of the connector, and then tighten the screw to 1.3 N m (10 lb-in) of torque.

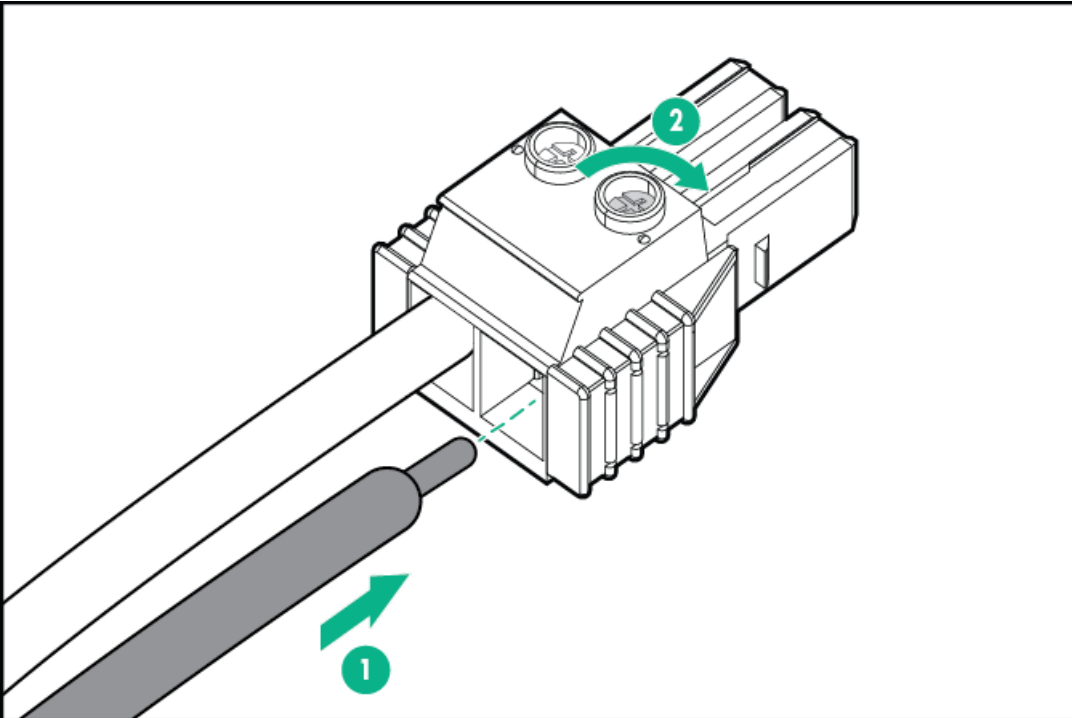

9. Install the terminal block connector into the power supply.

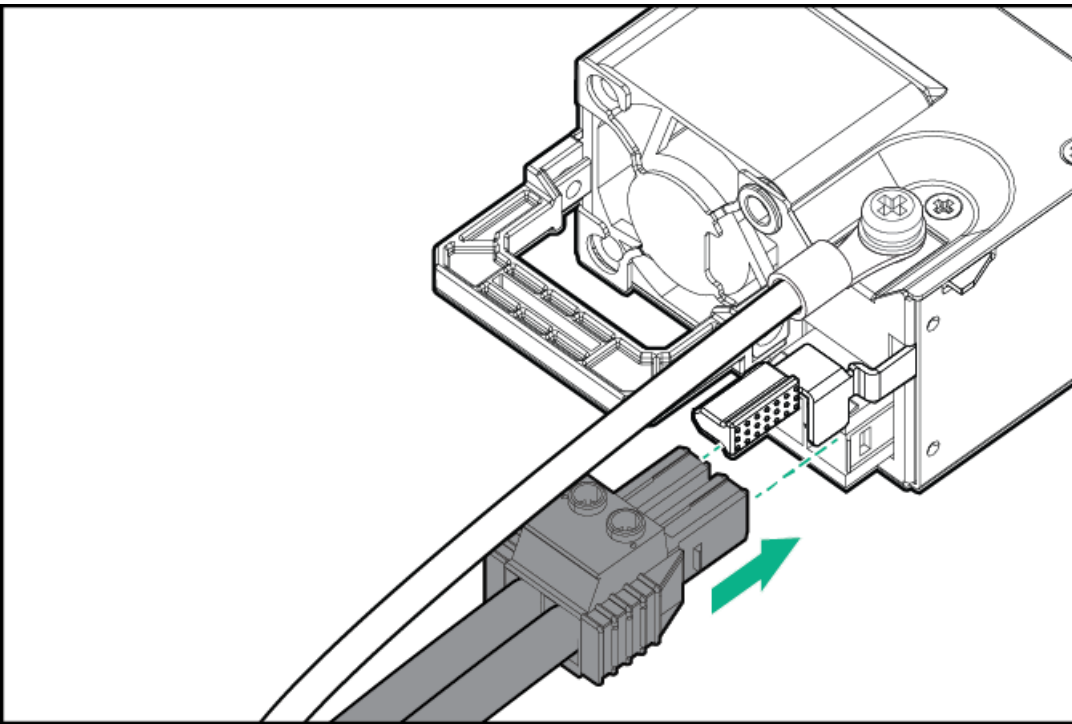

10. Secure the power cord, wires, and/or cables in the strain relief strap attached to the power supply handle:

- a. Unwrap the strain relief strap from the power supply handle.

△ CAUTION: Avoid tight bend radii to prevent damaging the internal wires of a power cord or a server cable. Never bend power cords and server cables tight enough to cause a crease in the sheathing.

- b. Secure the power cord, wires, and cables with the strain relief strap. Roll the extra length of the strap around the power supply handle.

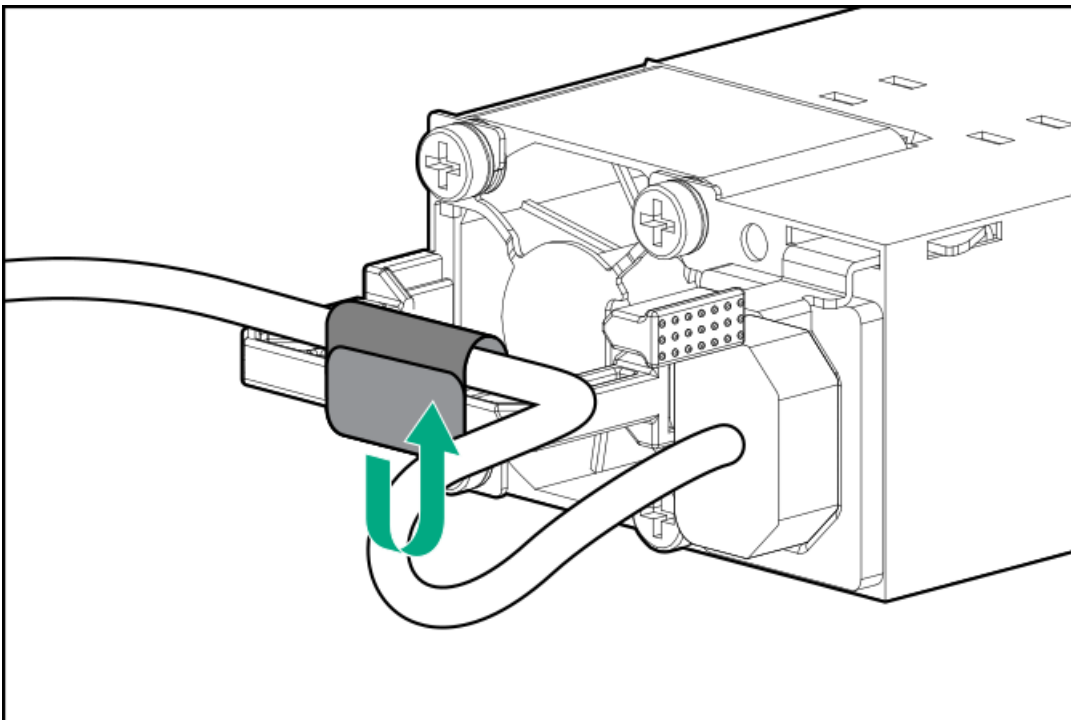

11. Slide the power supply into the bay until it clicks into place.

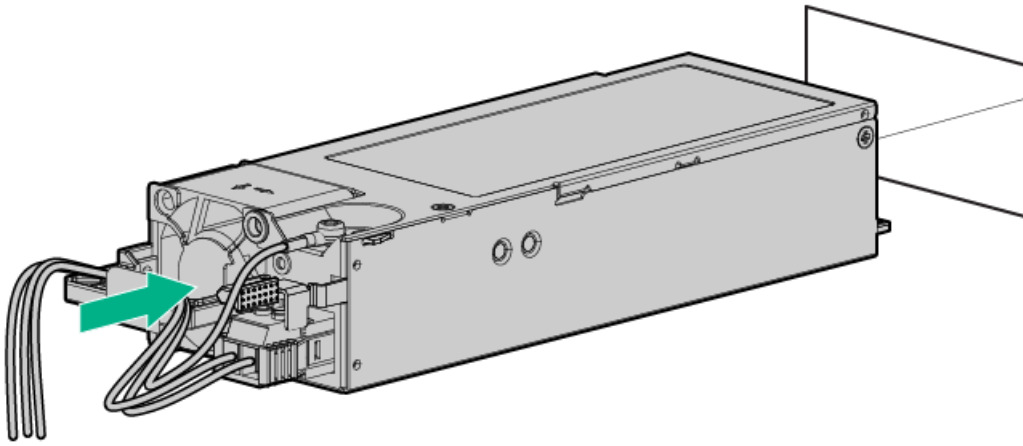

12. Make sure the -48 V DC power source is off or the PDU breaker is in the off position, and then connect the power cord to the -48 V DC power source or PDU.
13. To supply -48 V to the power supply, turn on the -48 V power source or switch the PDU breaker to the on position.
14. Be sure that the power supply LED is green.

Installing the HPE 1600 W Flex Slot -48 VDC hot-plug power supply

The DC power supply option kits do not ship with a Power Supply DC cable Kit and may not include a Power Supply Cable Lug kit. The optional DC Cable kit or the optional DC Cable Lug Kit may be purchased directly from Hewlett Packard Enterprise or an authorized HPE reseller. For additional information, refer to the power supply QuickSpecs at <https://www.hpe.com/info/fsps-qs>.

WARNING:

To reduce the risk of electric shock, fire, and damage to the equipment, you must install this product in accordance with the following guidelines:

- The HPE 1600 W Flex Slot -48 VDC hot-plug power supply is intended only for installation in Hewlett Packard Enterprise servers located in a restricted access location.
- The HPE 1600 W Flex Slot -48 VDC hot-plug power supply is not intended for direct connection to the DC supply branch circuit. Only connect this power supply to a power distribution unit (PDU) that provides an independent overcurrent-protected output for each DC power supply. Each output overcurrent-protected device in the PDU must be suitable for interrupting fault current available from the DC power source and must be rated no more than 45 A.
- The PDU output must have a shut-off switch or a circuit breaker to disconnect power for each power supply. To completely remove power from the power supply, disconnect power at the PDU. The end product may have multiple power supplies. To remove all power from the product, disconnect the power for each power supply.
- In accordance with applicable national requirements for Information Technology Equipment and Telecommunications Equipment, this power supply only connects to DC power sources that are classified as SELV or TNV. Generally, these requirements are based on the International Standard for Information Technology Equipment, IEC 60950-1/IEC 62368-1. In accordance with local and regional electric codes and regulations, the DC source must have one pole (Neutral/Return) reliably connected to earth ground.
- You must connect the power supply ground screw located on the front of the power supply to a suitable ground (earth) terminal. In accordance with local and regional electric codes and regulations, this terminal must be connected to a suitable building ground (earth) terminal. Do not rely on the rack or cabinet chassis to provide adequate ground (earth) continuity.

Prerequisites

Before you install this option, make sure that you have the following items available:

- No. 1 Phillips screwdriver
- If you are not using an input power cord option, the power supply cabling must be made in consultation with a licensed electrician and be compliant with local code.
- Optional P36877-B21 HPE lug kit can be purchased from an HPE authorized reseller for use with customer-supplied power cables. (The power cable and lug kit listed below can only be used with the 1600 W -48 VDC power supply.)
- If you are using an input power cord option, the P22173-B21 HPE 1600 W DC PSU power cable kit can be purchased from an authorized HPE reseller. (The power cable and lug kit listed below can only be used with the 1600 W -48 VDC power supply.)

1600 W -48VDC power cable color codes

Cable color	Description
Black	Positive return
Red	Negative input voltage
Green/yellow	Safety ground

Procedure

1. If necessary, remove the power supply blank.

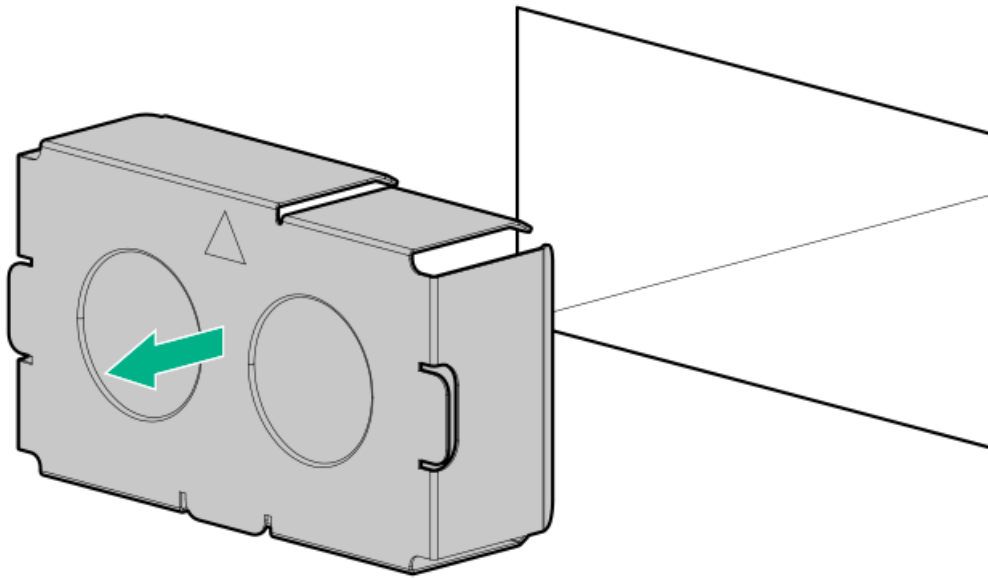

2. Remove the clear plastic cover on the side of the power supply.

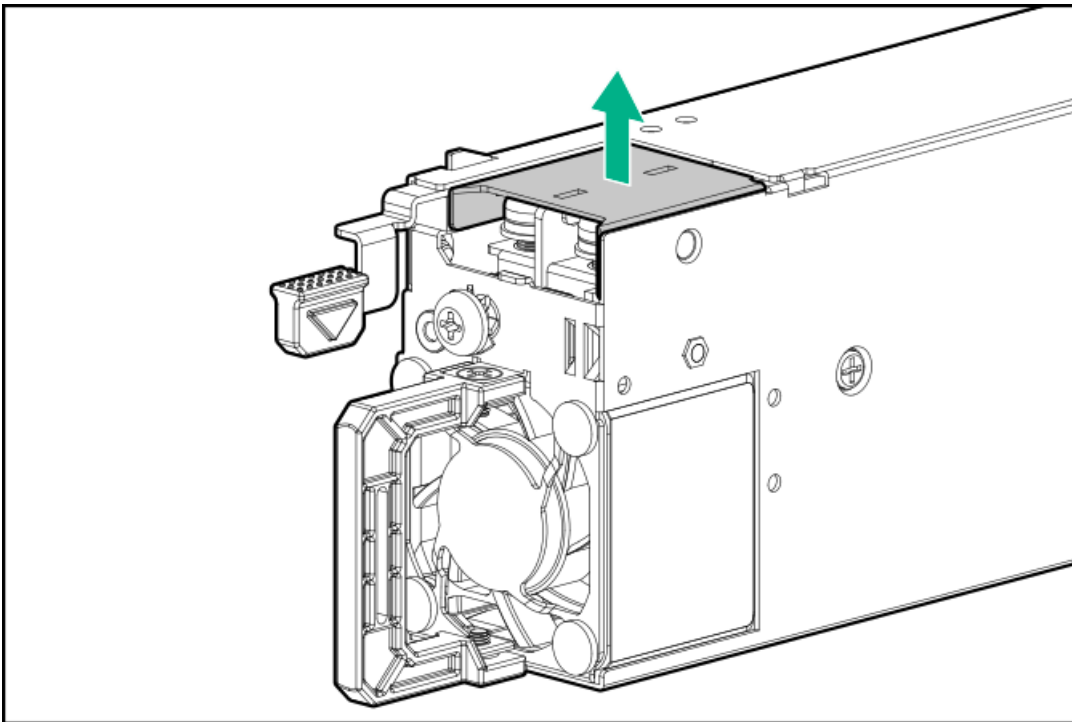

3. Do the following:
 - a. Remove the grounding screw from the front of the power supply.
 - b. Remove the four screws from the -48 V wire and return wire connectors.

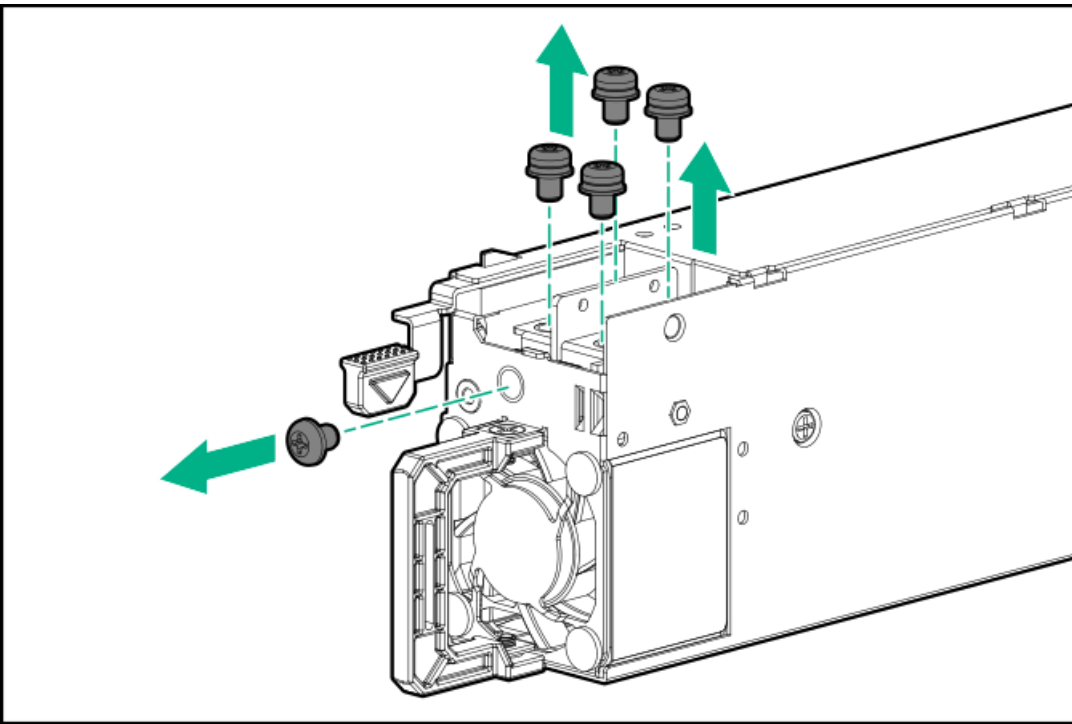

4. Attach the -48 V wire and the return wire to the connectors as marked and tighten to 0.98 N m (8.68 lb-in) of torque.

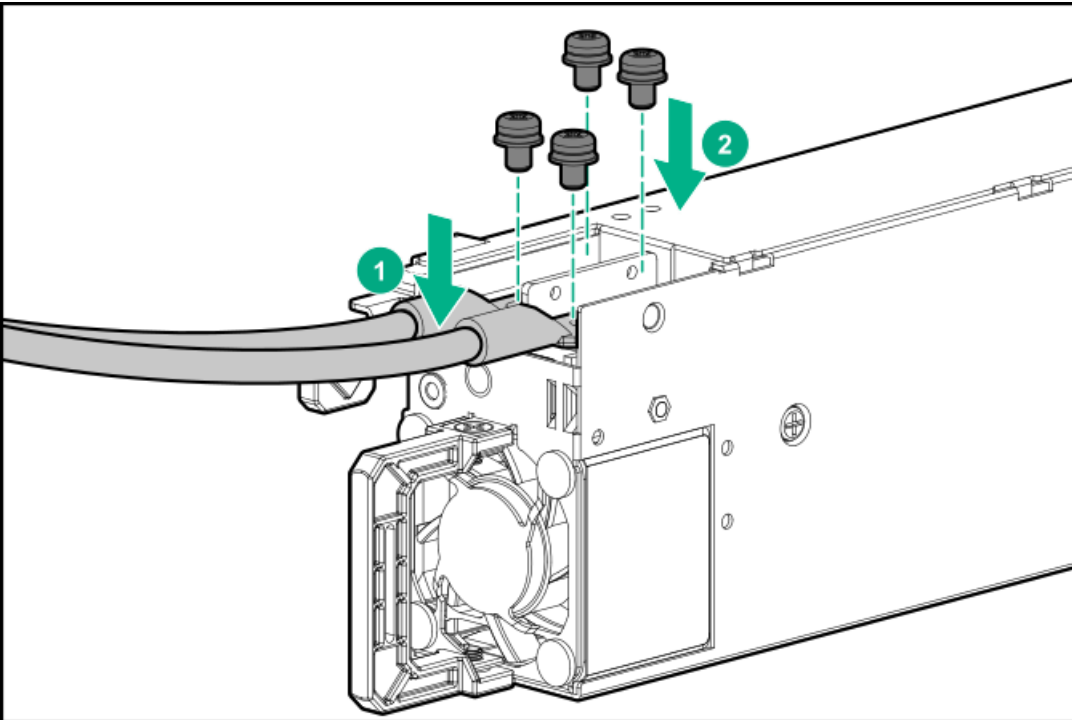

5. Attach the ground (earthed) wire to the ground screw and tighten to 1.47 N m (13 lb-in) of torque.



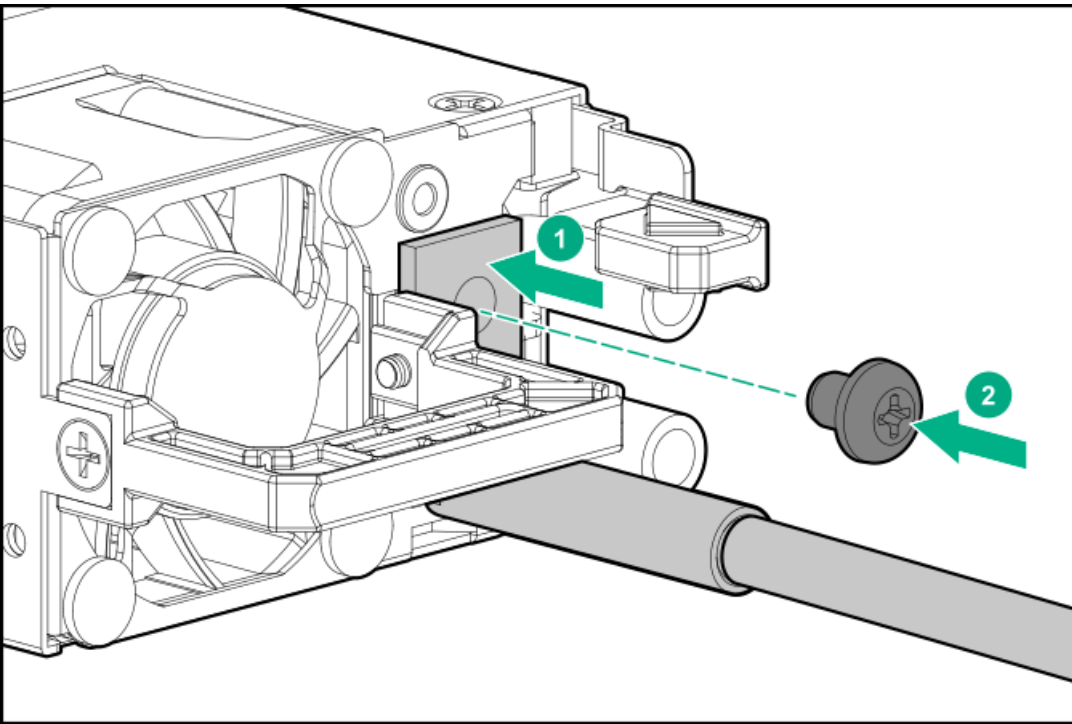

6. Replace the clear plastic cover on the -48 V and return connectors.
7. Secure the power cord, wires, and/or cables in the strain relief strap attached to the power supply handle:
 - a. Unwrap the strain relief strap from the power supply handle.

⚠ CAUTION: Avoid tight bend radii to prevent damaging the internal wires of a power cord or a server cable. Never bend power cords and server cables tight enough to cause a crease in the sheathing.

- b. Secure the wires and cables with the strain relief strap. Roll the extra length of the strap around the power supply handle.

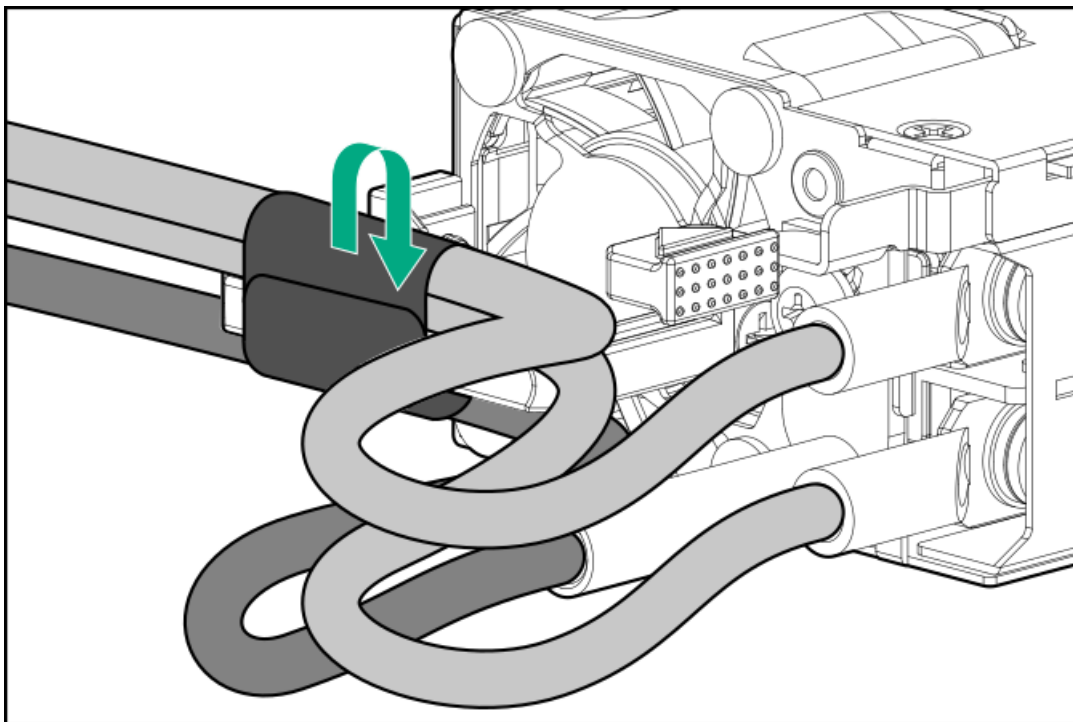

8. Slide the power supply into the bay until it clicks into place.
9. Make sure the -48 VDC power source is off or the PDU breaker is in the off position.
10. Connect the power cord to the -48 VDC power source or PDU.
11. Turn on the -48 V power source or switch the PDU breaker to the on position to supply -48 V to the power supply.

12. Make sure that the power supply LED is green.

Connecting a DC power cable to a DC power source

WARNING:

To reduce the risk of electric shock or energy hazards:

- This equipment must be installed by trained service personnel, as defined by the NEC and IEC 60950-1/IEC 62368-1, the standard for Safety of Information Technology Equipment.
- Connect the equipment to a reliably grounded secondary circuit source. A secondary circuit has no direct connection to a primary circuit and derives its power from a transformer, converter, or equivalent isolation device.
- The overcurrent protection for the DC source must not exceed 45 A.

WARNING:

When installing a DC power supply, the ground wire must be connected before the positive or negative leads.

WARNING:

Remove power from the power supply before performing any installation steps or maintenance on the power supply.

△ CAUTION:

The server equipment connects the earthed conductor of the DC supply circuit to the earthing conductor at the equipment. For more information, see the documentation that ships with the power supply.

△ CAUTION:

If a DC connection exists between the earthed conductor of the DC supply circuit and the earthing conductor at the server equipment, the following conditions must be met:

- This equipment must be connected directly to the DC supply system earthing electrode conductor or to a bonding jumper from an earthing terminal bar or bus to which the DC supply system earthing electrode conductor is connected.
- Locate the equipment in the same immediate area (such as adjacent cabinets) as any other equipment that has a connection between the earthed conductor of the same DC supply circuit and the earthing conductor, and also the point of earthing of the DC system. The DC system must be earthed elsewhere.
- The DC supply source is to be located within the same premises as the equipment.
- Switching or disconnecting devices should not be in the earthed circuit conductor between the DC source and the point of connection of the earthing electrode conductor.

Procedure

1. Cut the DC power cord ends no shorter than 150 cm (59.06 in).

ⓘ IMPORTANT:

The ring terminals must be UL approved and accommodate 12 gauge wires.

ⓘ IMPORTANT:

The minimum nominal thread diameter of a pillar or stud type terminal must be 3.5 mm (0.138 in). The diameter of a screw type terminal must be 5.0 mm (0.197 in).

2. If the power source requires ring tongues, use a crimping tool to install the ring tongues on the power cord wires.
3. Stack each same-colored pair of wires and then attach them to the same power source. The power cord consists of three wires (black, red, and green).

For more information, see the documentation that ships with the power supply.



Energy pack options

Hewlett Packard Enterprise offers two backup power options to back up write cache content on the controllers in case of an unplanned server power outage.

- [HPE Smart Storage Battery](#)
- [HPE Smart Storage Hybrid Capacitor](#)

ⓘ IMPORTANT:

The HPE Smart Storage Hybrid Capacitor is only supported on Gen10 and later servers. For a list of supported controllers, see the [product QuickSpecs](#).

Once installed, the status of the energy pack displays in HPE iLO. For more information, see the HPE iLO user guide on the [Hewlett Packard Enterprise website](#).

HPE Smart Storage Battery

The HPE Smart Storage Battery supports the following devices:

- HPE Smart Array SR controllers

A single 96W battery can support up to 24 devices.

After the battery is installed, it might take up to two hours to charge. Controller features requiring backup power are not re-enabled until the battery is capable of supporting the backup power.

This server supports the 96W HPE Smart Storage Battery with the 145mm cable.

HPE Smart Storage Hybrid Capacitor

The HPE Smart Storage Hybrid Capacitor supports the following devices:

- HPE SmartRAID SR controllers

The capacitor pack can support up to two devices.

This server supports the HPE Smart Storage Hybrid Capacitor with the 145mm cable.

Before installing the HPE Smart Storage Hybrid Capacitor, verify that the system BIOS meets the minimum firmware requirements to support the capacitor pack.

i IMPORTANT:

If the system BIOS or controller firmware is older than the minimum recommended firmware versions, the capacitor pack will only support one device.

The capacitor pack is fully charged after the system boots.

Minimum firmware versions

Product	Minimum firmware version
HPE ProLiant DL380 Gen10 Plus Server system ROM	1.40
HPE Smart Array SR controllers	3.53



Installing an energy pack

Prerequisites

Before installing this option, be sure you that have the components included with the hardware option kit.

Procedure

1. Power down the server.
2. Remove all power:
 - a. Disconnect each power cord from the power source.
 - b. Disconnect each power cord from the server.
3. Do one of the following:
 - a. Extending the server from the rack.
 - b. Removing the server from the rack.
4. Remove the access panel.
5. Install the energy pack and connect the energy pack cable.

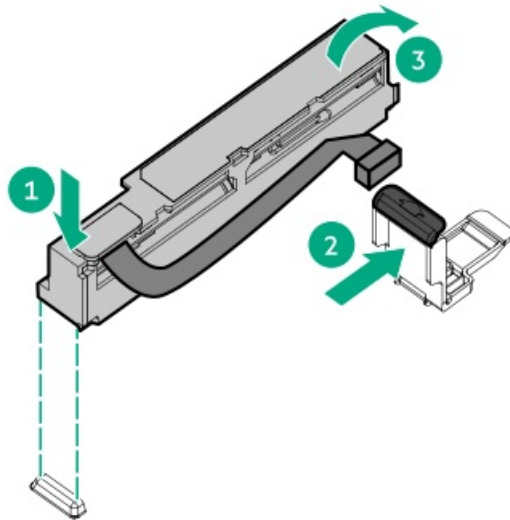

6. Install the access panel.
7. Install the server in the rack.
8. Connect each power cord to the server.
9. Connect each power cord to the power source.
10. Power up the server.

The installation is complete.

Memory options

- ⓘ **IMPORTANT:** This server does not support mixing LRDIMMs and RDIMMs. Attempting to mix any combination of these DIMMs can cause the server to halt during BIOS initialization. All memory installed in the server must be of the same type.
-

Memory population information

For specific memory population information, see the memory population guidelines on the Hewlett Packard Enterprise website (<https://www.hpe.com/docs/memory-population-rules>).



DIMM-processor compatibility

The installed processor determines the type of DIMM that is supported in the server:

- Third-generation Intel Xeon Scalable processors support DDR4-3200 DIMMs.

Mixing DIMM types is not supported. Install only the supported DDR4-3200 DIMMs in the server.

HPE SmartMemory speed information

For more information about memory speed information, see the Hewlett Packard Enterprise website (<https://www.hpe.com/docs/memory-speed-table>).



Installing a DIMM blank

Use the following table to decide if the thermal restrictions of the server require DIMM blanks in all open slots of your configuration.

Processor TDP	DIMM blank installation
105W to 140W	Recommended
230W to 270W	Recommended
150W to 270W	Required

Procedure

1. Power down the server.
2. Remove all power:
 - a. Disconnect each power cord from the power source.
 - b. Disconnect each power cord from the server.
3. Do one of the following:
 - a. Extend the server from the rack.
 - b. Remove the server from the rack.
4. Remove the access panel.
5. Open the DIMM slot latches.
6. Install the DIMM blank.

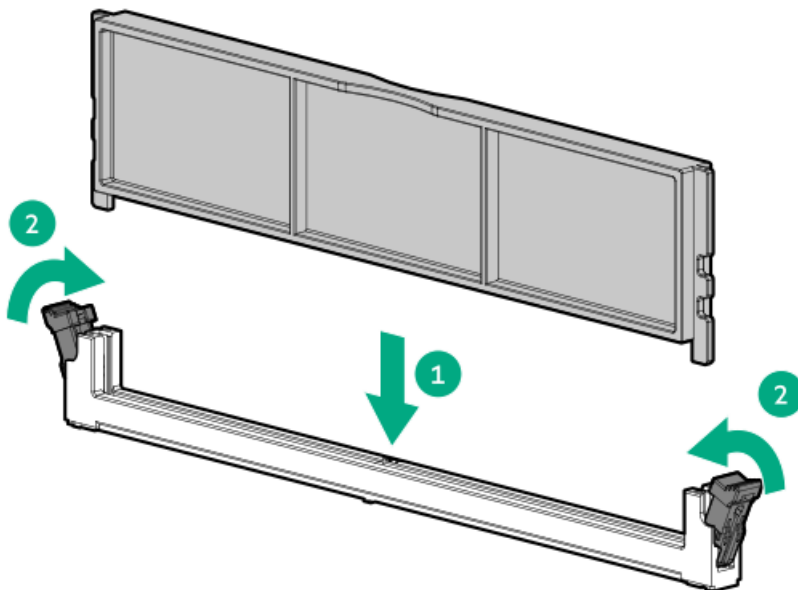

Installing a DIMM

The server supports up to 32 DIMMs.

Prerequisites

Before installing this option, be sure you have the following:

The components included with the hardware option kit

For more information on specific options, see the server QuickSpecs on the [Hewlett Packard Enterprise website](#).

Procedure

1. [Power down the server.](#)
2. Remove all power:
 - a. Disconnect each power cord from the power source.
 - b. Disconnect each power cord from the server.
3. Do one of the following:
 - a. [Extend the server from the rack.](#)
 - b. [Remove the server from the rack.](#)
4. [Remove the access panel.](#)
5. Open the DIMM slot latches.
6. Install the DIMM.

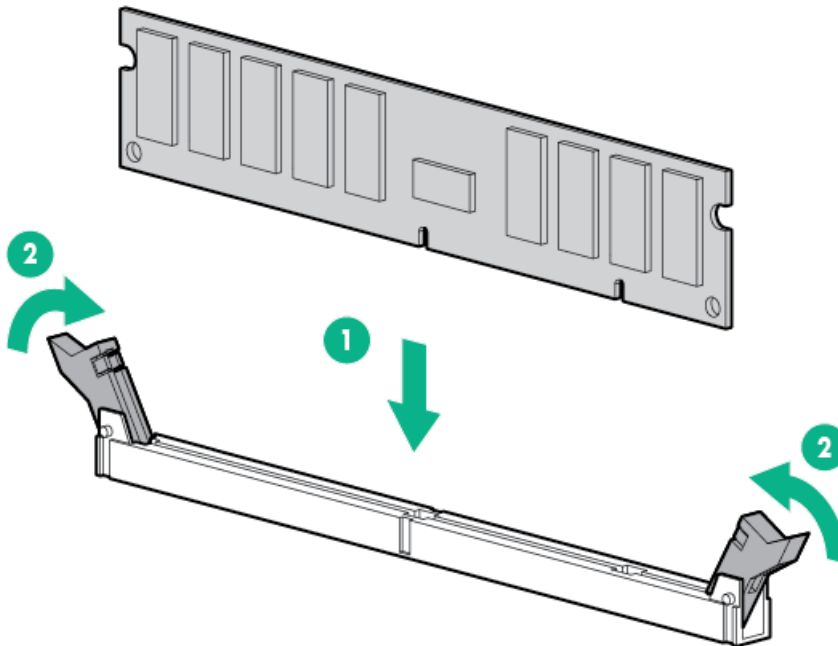

7. [Install the access panel.](#)
8. Install the server in the rack.
9. Connect each power cord to the server.
10. Connect each power cord to the power source.
11. [Power up the server.](#)

Use the BIOS/Platform Configuration (RBSU) in the UEFI System Utilities to configure the memory mode.

For more information about LEDs and troubleshooting failed DIMMs, see "[Systems Insight Display combined LED descriptions.](#)"

Intel Optane persistent memory 200 series for HPE

Intel Optane persistent memory 200 series for HPE offers the flexibility to deploy memory as dense memory (Memory mode) or fast storage (App Direct mode) and enables per-socket memory capacity of up to 6.0 TB. Persistent memory modules, together with traditional volatile DRAM DIMMs, provide fast, high-capacity, cost-effective memory and storage to transform big data workloads and analytics by enabling data to be stored, moved, and processed quickly.

Persistent memory modules use the standard DIMM form factor and are installed alongside DIMMs in a server memory slot. Intel Optane persistent memory 200 series for HPE is designed for use only with third-generation Intel Xeon Scalable processors, and is available in the following capacities:

- 128 GB
- 256 GB
- 512 GB

Persistent memory module-processor compatibility

Intel Optane persistent memory 200 series for HPE is supported only in servers with second-generation Intel Xeon Scalable processors installed.

Persistent memory module population information

For specific population and configuration information, see the memory population guidelines on the Hewlett Packard Enterprise website (<https://www.hpe.com/docs/memory-population-rules>).

System requirements for persistent memory module support

i IMPORTANT:

Hewlett Packard Enterprise recommends that you implement best-practice configurations such as clustered configurations for high availability (HA).

Before installing persistent memory modules, make sure that the following components and software are available:

- A supported HPE ProLiant Gen10 Plus server or Synergy compute module using third-generation Intel Xeon Scalable processors.

For more information, see the product QuickSpecs on the Hewlett Packard Enterprise website (<https://www.hpe.com/support/persistentmemoryQS>).

- HPE DDR4 Standard Memory RDIMMs or LRDIMMs (the number will vary based on your chosen configuration).
- Supported firmware and drivers:
 - System ROM version 1.40 or later
 - Server Platform Services (SPS) Firmware version 04.04.04.053
 - HPE iLO 5 Firmware version 2.44
 - HPE Innovation Engine Firmware version 1.0.0.20 or later

Download the required firmware and drivers from the Hewlett Packard Enterprise website (<https://www.hpe.com/info/persistentmemory>).

- A supported operating system:
 - Windows Server 2016 with persistent memory drivers from Hewlett Packard Enterprise
 - Windows Server 2019
 - Red Hat Enterprise Linux 7.9 and later
 - Red Hat Enterprise Linux 8.2 and later
 - SUSE Linux Enterprise Server 12 SP5 and later
 - SUSE Linux Enterprise Server 15 SP2 and later
 - VMware vSphere 7.0 U2 and later
 - VMware vSphere 6.7 U3 with P03
- Hardware and licensing requirements for optional encryption of the persistent memory modules:
 - HPE TPM 2.0 (local key encryption)
 - HPE iLO Advanced License (remote key encryption)
 - Key management server (remote key encryption)

For more information, see the Intel Optane persistent memory 200 series for HPE User Guide on the Hewlett Packard Enterprise website (<https://www.hpe.com/info/persistentmemory-docs>).

Installing persistent memory modules

Use this procedure only for new persistent memory module installations. If you are migrating this persistent memory module from another server, see the Intel Optane persistent memory 200 series for HPE User Guide on the Hewlett Packard Enterprise website (<https://www.hpe.com/info/persistentmemory-docs>).

Prerequisites

Before you perform this procedure, make sure that you have the following items available:

- The components included with the hardware option kit
- A T-10 Torx screwdriver might be needed to unlock the access panel.

Procedure

1. Observe the following alerts:

⚠ CAUTION:

DIMMs and persistent memory modules are keyed for proper alignment. Align notches on the DIMM or persistent memory module with the corresponding notches in the slot before installing the component. Do not force the DIMM or persistent memory module into the slot. When installed properly, not all DIMMs or persistent memory modules will face in the same direction.

⚠ CAUTION:

Electrostatic discharge can damage electronic components. Be sure you are properly grounded before beginning this procedure.

⚠ CAUTION:

Failure to properly handle persistent memory modules can damage the component and the system board connector.

ⓘ IMPORTANT:

Hewlett Packard Enterprise recommends that you implement best-practice configurations such as clustered configurations for high availability (HA).

2. Power down the server ([Power down the server](#)).
3. Remove all power:
 - a. Disconnect each power cord from the power source.
 - b. Disconnect each power cord from the server.
4. Do one of the following:
 - a. Extend the server from the rack ([Extending the server from the rack](#)).
 - b. Remove the server from the rack ([Removing the server from the rack](#)).
5. Place the server on a flat, level work surface.
6. [Remove the access panel](#).
7. Open the DIMM slot latches.
8. Install the persistent memory module.

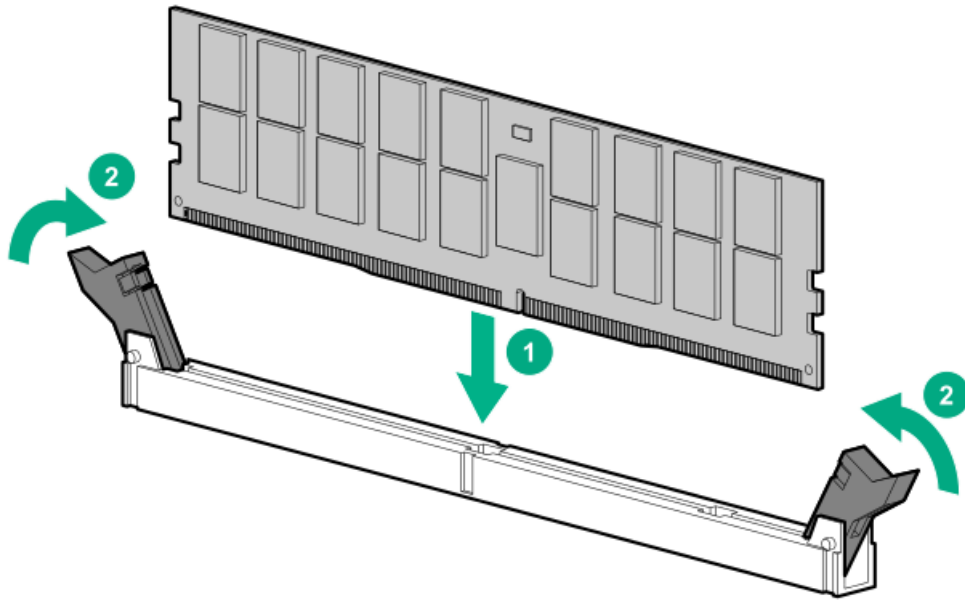

9. Install the access panel (Install the access panel).
10. Slide or install the server into the rack.
11. If removed, reconnect all power cables.
12. Power up the server.
13. Configure the server for Intel Optane persistent memory for HPE.

Configuring the server for Intel Optane persistent memory 200 series for HPE

After installing persistent memory modules, configure the server for Intel Optane persistent memory for HPE.

i IMPORTANT:

Always follow recommendations from your software application provider for high-availability best practices to ensure maximum uptime and data protection.

A number of configuration tools are available, including:

- UEFI System Utilities—Configure the server by using the UEFI System Utilities through the Remote Console. To access the UEFI System Utilities, press F9 during POST.
- iLO RESTful API—Use the iLO RESTful API through tools such as the RESTful Interface Tool (ilorest) or other third-party tools.

For more information, see the Intel Optane persistent memory 200 series for HPE User Guide on the Hewlett Packard Enterprise website (<https://www.hpe.com/info/persistentmemory-docs>).

Fan options

CAUTION: To avoid damage to server components, fan blanks must be installed in fan bays 1 and 2 in a single-processor configuration.

CAUTION: To avoid damage to the equipment, do not operate the server for extended periods of time if the server does not have the optimal number of fans installed. Although the server might boot, Hewlett Packard Enterprise does not recommend operating the server without the required fans installed and operating.

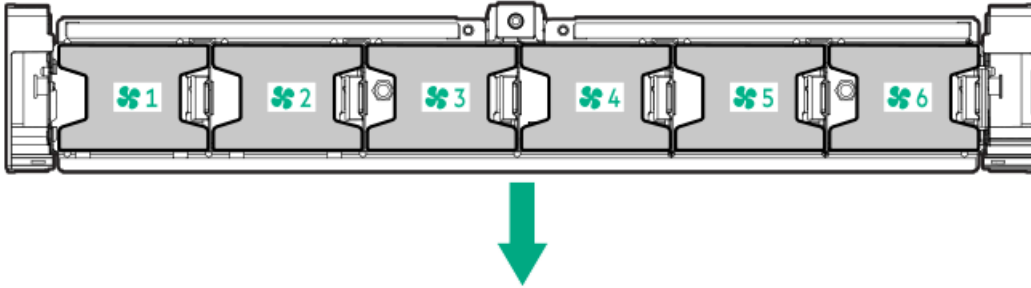

Valid fan configurations are listed in the following table.

Configuration	Fan bay 1	Fan bay 2	Fan bay 3	Fan bay 4	Fan bay 5	Fan bay 6
1 processor	Fan blank	Fan blank	Fan	Fan	Fan	Fan
1 processor 24-SFF or 12-LFF configuration with high- performance fans	Fan	Fan	Fan	Fan	Fan	Fan
2 processors	Fan	Fan	Fan	Fan	Fan	Fan

For a single-processor configuration, excluding 24-SFF and 12-LFF configurations, four fans and two blanks are required in specific fan bays for redundancy. A fan failure or missing fan causes a loss of redundancy. A second fan failure or missing fan causes an orderly shutdown of the server.

For a dual-processor configuration or single-processor 24-SFF or 12-LFF configurations, six fans are required for redundancy. A fan failure or missing fan causes a loss of redundancy. A second fan failure or missing fan causes an orderly shutdown of the server.

High-performance fans might be necessary in 24-SFF and 12-LFF configurations for the following installations:

- Optional GPU riser installations
- ASHRAE compliant configurations
For more information, see the [Hewlett Packard Enterprise website](#).

The server supports variable fan speeds. The fans operate at minimum speed until a temperature change requires a fan speed increase to cool the server. The server shuts down during the following temperature-related scenarios:

- At POST and in the OS, iLO performs an orderly shutdown if a cautionary temperature level is detected. If the server hardware detects a critical temperature level before an orderly shutdown occurs, the server performs an immediate shutdown.
- When the Thermal Shutdown feature is disabled in the BIOS/Platform Configuration (RBSU), iLO does not perform an orderly shutdown when a cautionary temperature level is detected. Disabling this feature does not disable the server hardware from performing an immediate shutdown when a critical temperature level is detected.

CAUTION: A thermal event can damage server components when the Thermal Shutdown feature is disabled in the BIOS/Platform Configuration (RBSU).

Installing high-performance fans

⚠ CAUTION: Caution: To prevent damage server, ensure that all DIMM latches are closed and locked before installing the fans.

⚠ CAUTION:

Do not operate the server for long periods with the access panel open or removed. Operating the server in this manner results in improper airflow and improper cooling that can lead to thermal damage.

Procedure

1. Extend the server from the rack.
2. Remove the access panel.
3. If installed, remove all fan blanks.

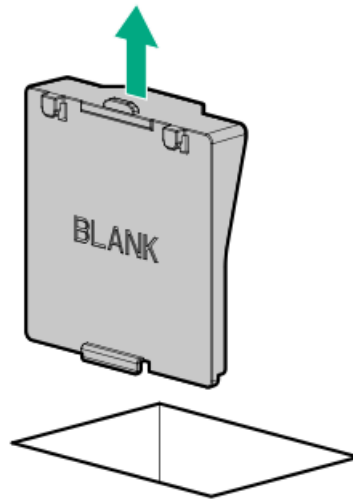

4. Remove the air baffle.
5. Remove all standard fans.

i IMPORTANT: Do not mix standard fans and high-performance fans in the same server.

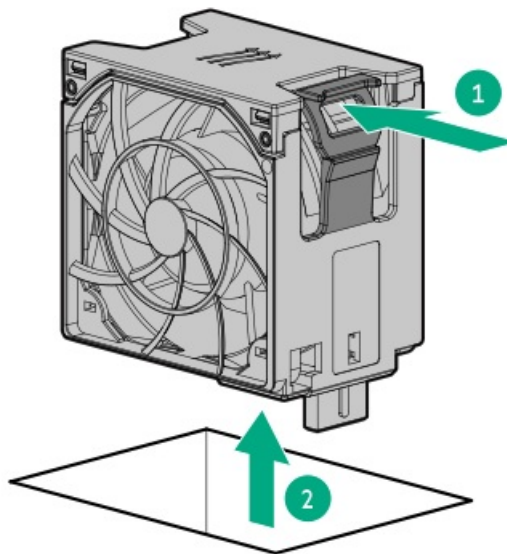

6. Install high-performance fans in all fan bays.

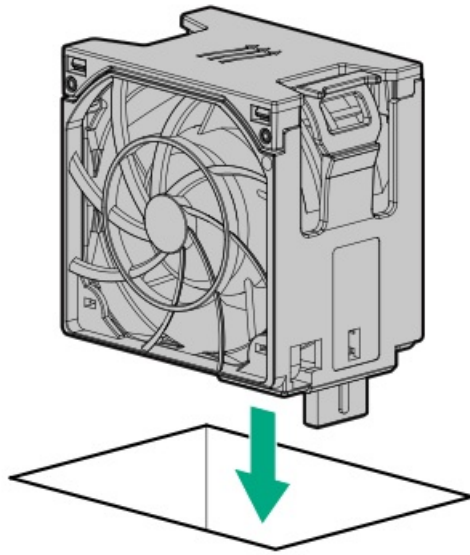

7. Install the air baffle.

8. Install the access panel.

The installation is complete.

Drive options

Depending on the configuration, this server supports SAS, SATA, NVMe, and M.2 drives. For more information on drive support, see the product [QuickSpecs](#).

When adding hard drives to the server, observe the following general guidelines:

- The system automatically sets all device numbers.
- For drive numbering, see [Drive bay numbering](#).
- If using only one hard drive, install it in the bay with the lowest device number.
- To provide the greatest storage space efficiency, group identical capacity drives into the same drive array.
- The NVMe SSD is a PCIe bus device. Do not remove NVMe drives without allowing the device to cease activity. Removing the drive while active can cause data loss.



Drive guidelines

Depending on the configuration, the server supports SAS, SATA, and NVMe drives.

Observe the following general guidelines:

- The system automatically sets all drive numbers.
- If only one hard drive is used, install it in the bay with the lowest drive number.
For drive numbering, see [Drive bay numbering](#).
- The NVMe SSD is a PCIe bus device. Devices attached to a PCIe bus cannot be removed without allowing the device and bus to complete and cease the signal/traffic flow.
Do not remove an NVMe SSD from the drive bay while the Do Not Remove button LED is flashing. The Do Not Remove button LED flashes to indicate that the device is still in use. Removal of the NVMe SSD before the device has completed and ceased signal/traffic flow can cause loss of data.
- Drives with the same capacity provide the greatest storage space efficiency when grouped into the same drive array.

Installing a hot-plug SAS, SATA or NVMe drive

CAUTION: To prevent improper cooling and thermal damage, do not operate the server unless all drive and device bays are populated with either a component or a blank.

Procedure

1. Remove the drive blank:

- LFF drive blank

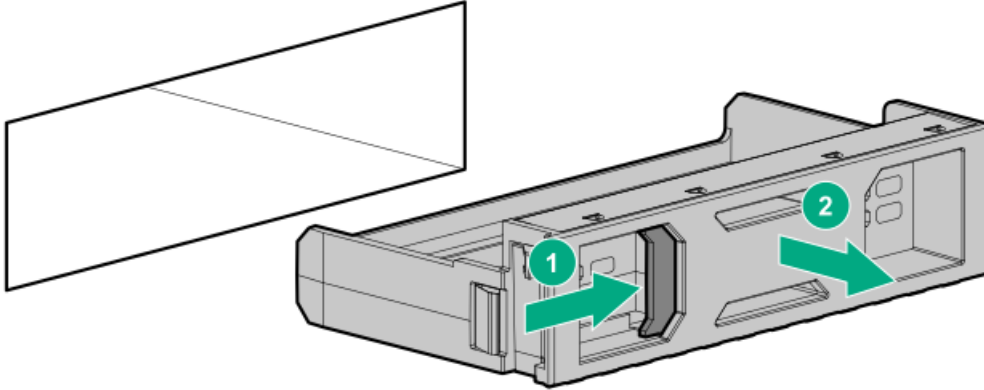

- SFF drive blank

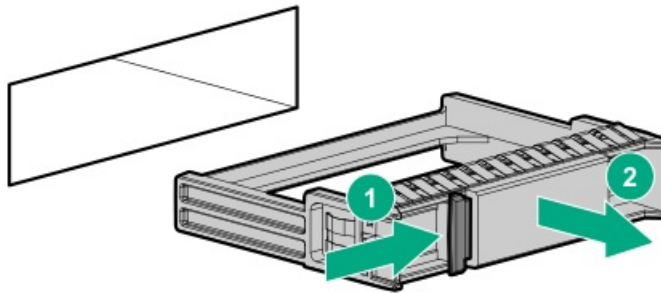

2. Prepare the drive.

- LFF drive

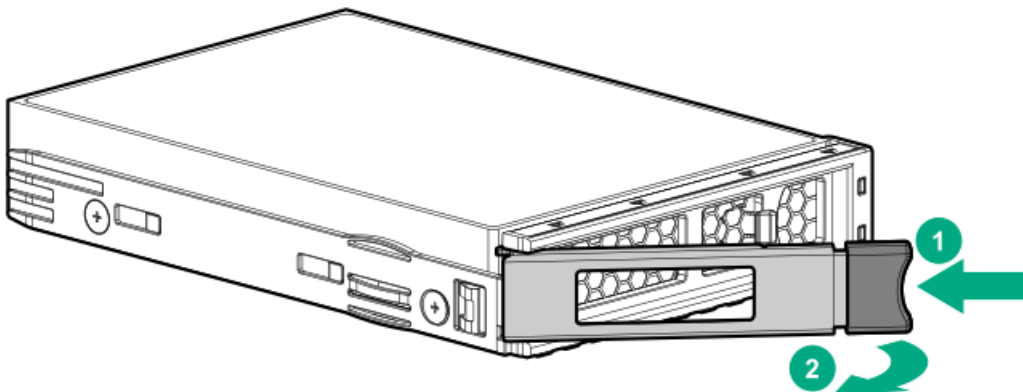

- SFF drive

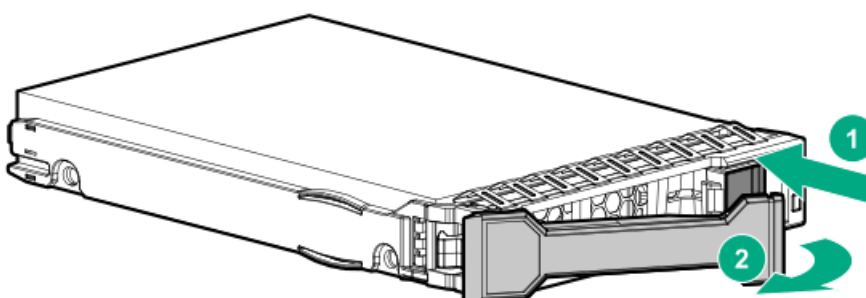

3. Install the drive.

- LFF drive

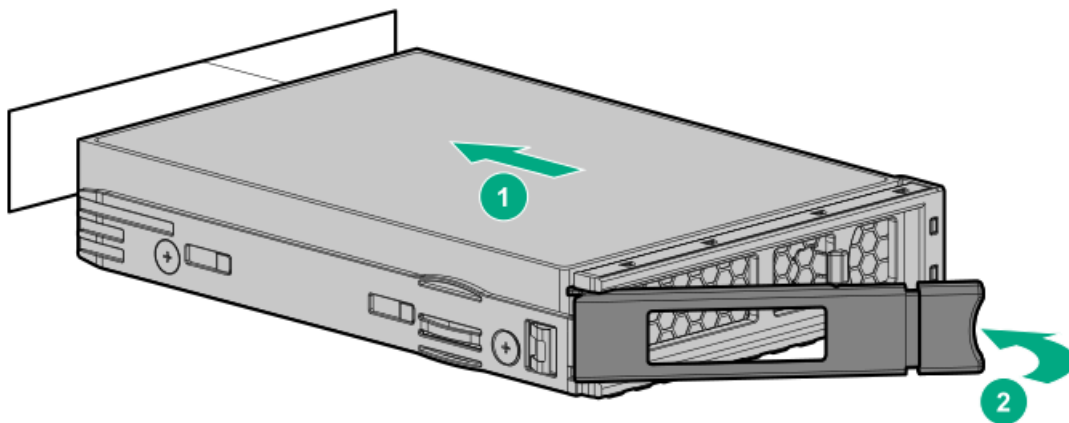

- SFF drive

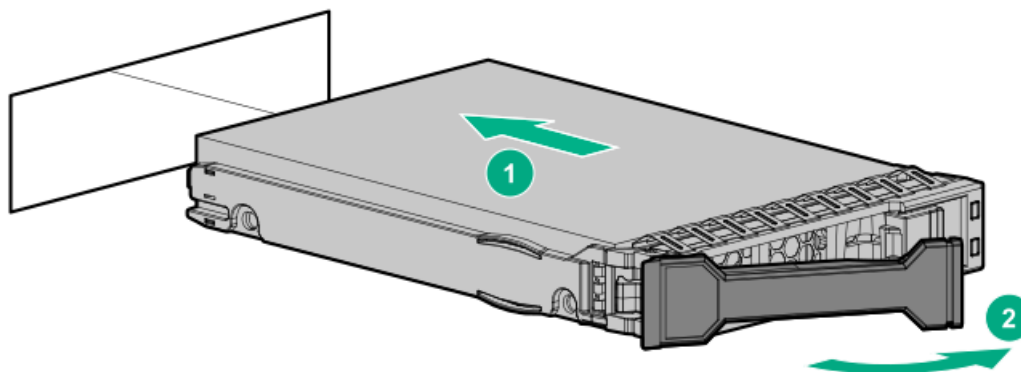

4. Determine the status of the drive from the drive LED definitions.

5. To configure drive arrays, see the following documentation for detailed instructions:

- HPE SR Gen10 Plus Software RAID User Guide at <https://www.hpe.com/support/SSC-SRGen10Plus-ug>
- HPE SmartRAID SR Gen10 Plus Controller User Guide at <https://www.hpe.com/info/SmartRAID-Gen10Plus-UG>
- HPE MegaRAID MR Gen10 Plus Controller User Guide at <https://www.hpe.com/info/MegaRAID-Gen10Plus-UG>

Installing an M.2 drive

This procedure is for replacing M.2 drives located on an expansion card, riser, or the system board only. Do not use this procedure to replace uFF drives.

Prerequisites

Before you perform this procedure, make sure that you have the following items available:

- The components included with the hardware option kit
- T-10 Torx screwdriver

Procedure

1. Power down the server.
2. Remove all power:
 - a. Disconnect each power cord from the power source.
 - b. Disconnect each power cord from the server.
3. Do one of the following:
 - Extend the server from the rack.
 - Remove the server from the rack.
4. Remove the access panel.
5. Remove the riser cage.
6. Install the drive.

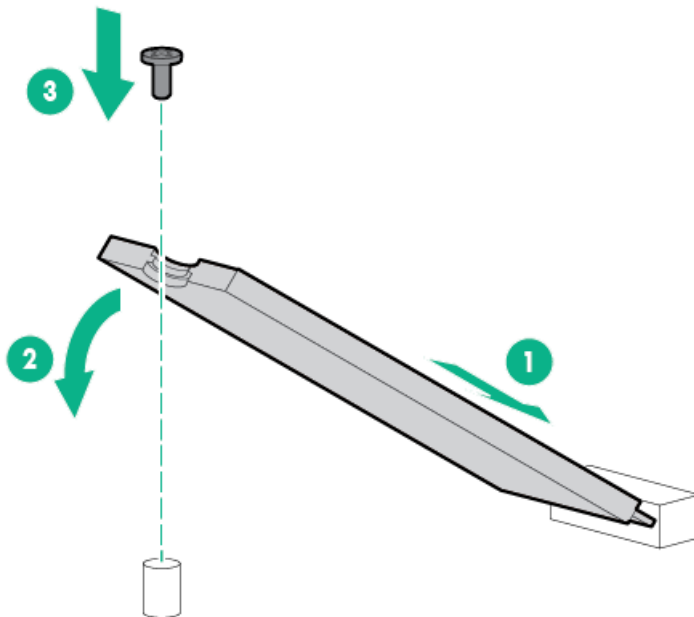

The installation is complete.

Installing a Universal Media Bay

Prerequisites

Before you perform this procedure, make sure that you have the following items available:

- The components included with the hardware option kit
- T-10 Torx screwdriver

Procedure

1. Power down the server.
2. Remove all power:
 - a. Disconnect each power cord from the power source.
 - b. Disconnect each power cord from the server.
3. Do one of the following:
 - Extend the server from the rack.
 - Remove the server from the rack.
4. Remove the access panel.
5. Remove the air baffle.
6. Remove the fan cage.
7. Remove the bay blank.

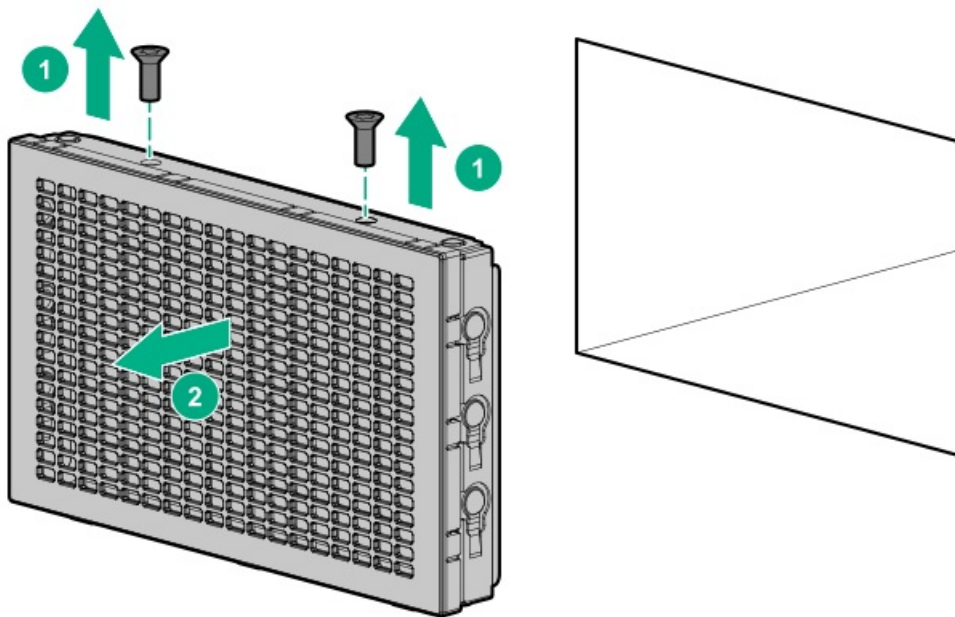

8. Route the USB and video cables through the opening.
9. If installing a two-bay SFF front drive cage, install the drive cage.
10. Install the universal media bay.

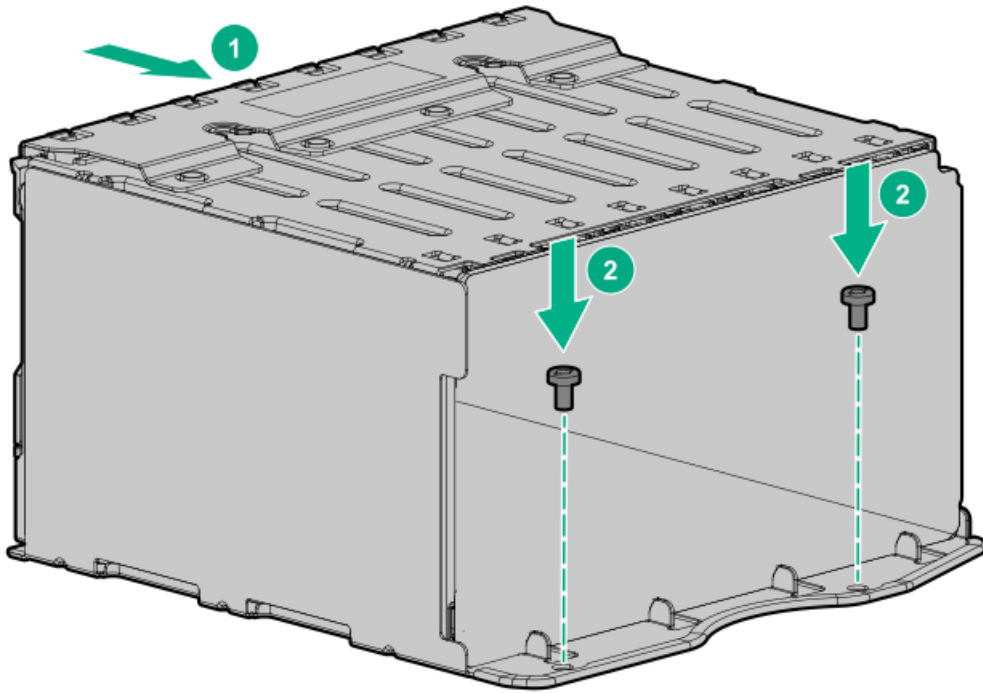

11. (Optional) Install the optical disk drive.

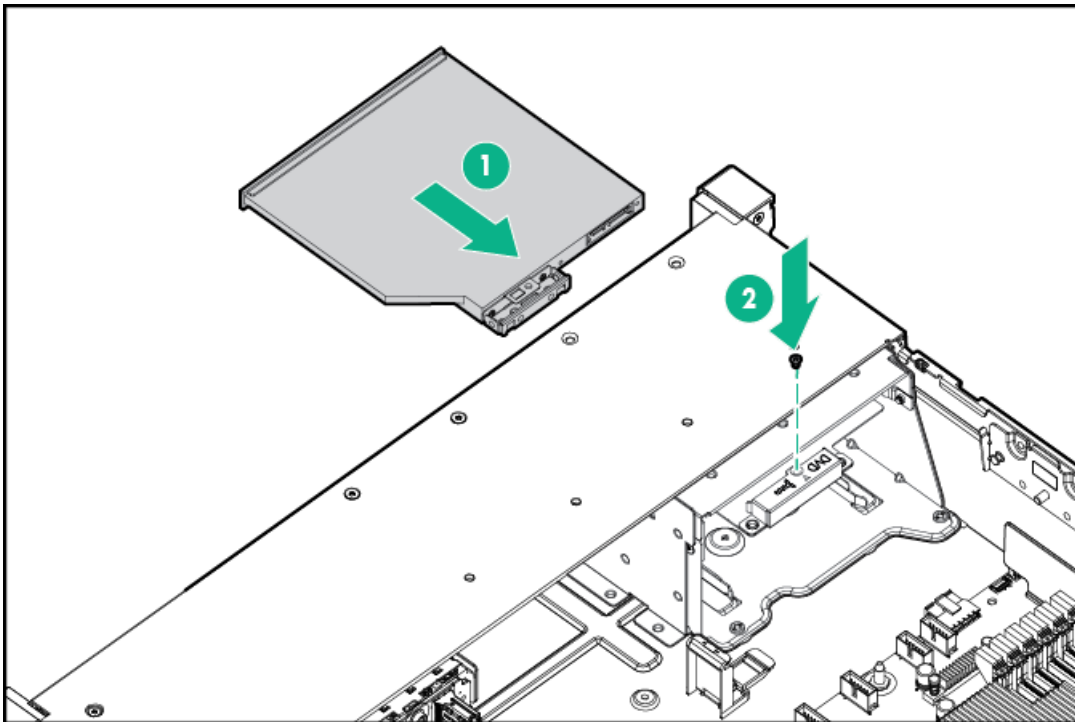

12. Connect the cables.
13. Install the fan cage.
14. Install the air baffle.
15. Install the access panel.
16. Slide the server into the rack.
17. Connect each power cord to the server.
18. Connect each power cord to the power source.
19. Power up the server.

The installation is complete.



Storage controller options

The server supports the following storage controllers:

- Embedded controllers
Enabled through UEFI System Utilities and configured using either System Utilities or the HPE Smart Storage Administrator (Intelligent Provisioning).
- Type-a controllers
Type-a controllers install in the type-a storage controller slot.
- Type-p controllers
Type-p controllers install in a PCIe expansion slot.

For a complete list of supported storage controller models, see the server QuickSpecs on the Hewlett Packard Enterprise website (<https://www.hpe.com/info/qs>).

Installing a storage controller

Prerequisites

Before you perform this procedure, make sure that you have the components included with the hardware option kit.

Procedure

1. Power down the server.
2. Remove all power:
 - a. Disconnect each power cord from the power source.
 - b. Disconnect each power cord from the server.
3. Do one of the following:
 - Extend the server from the rack.
 - Remove the server from the rack.
4. Remove the access panel.
5. Do one of the following:
 - Remove the air baffle.
 - If installed, remove the 4 LFF midplane drive cage.
6. Do one of the following:
 - For Type-a Smart Array controllers, install the controller in the Smart Array modular controller connector.

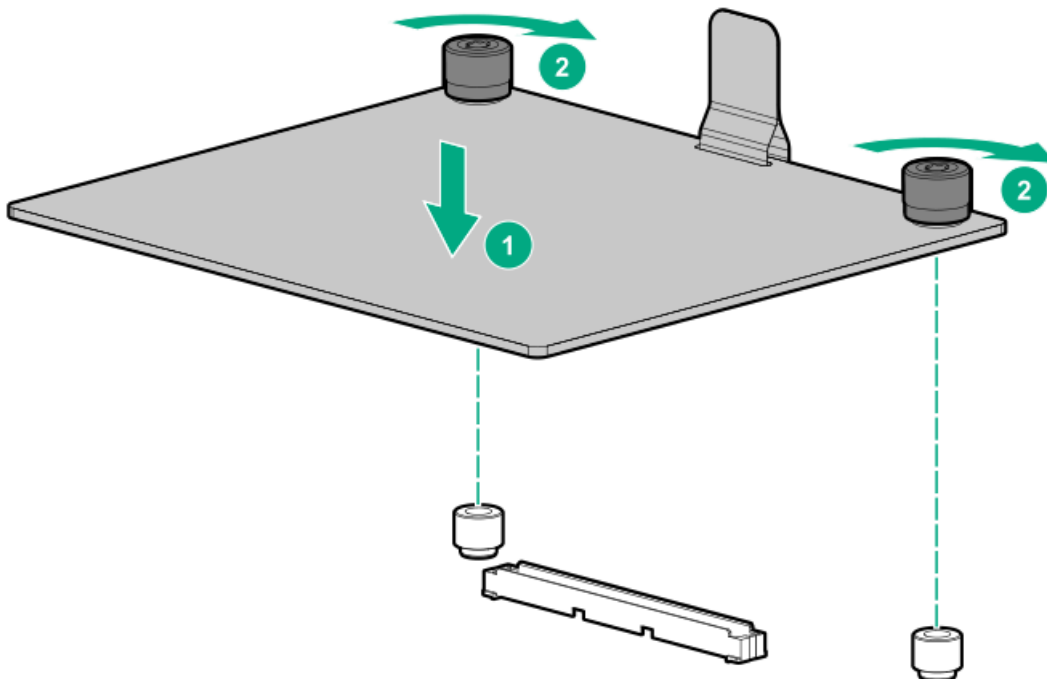

- For Type-p Smart Array controllers, install the controller in a compatible expansion slot.

7. Cable the controller.

The installation is complete.

Installing primary and secondary risers

Prerequisites

Before you perform this procedure, make sure that you have the following items available:

- The components included with the hardware option kit
- T-10 Torx screwdriver

Procedure

1. Power down the server.
2. Do one of the following:
 - Disconnect each power cord from the power source.
 - Disconnect each power cord from the server.
3. Do one of the following:
 - Extend the server from the rack.
 - Remove the server from the rack.
4. Remove the access panel.
5. Remove the riser cage.
6. Remove the riser board.

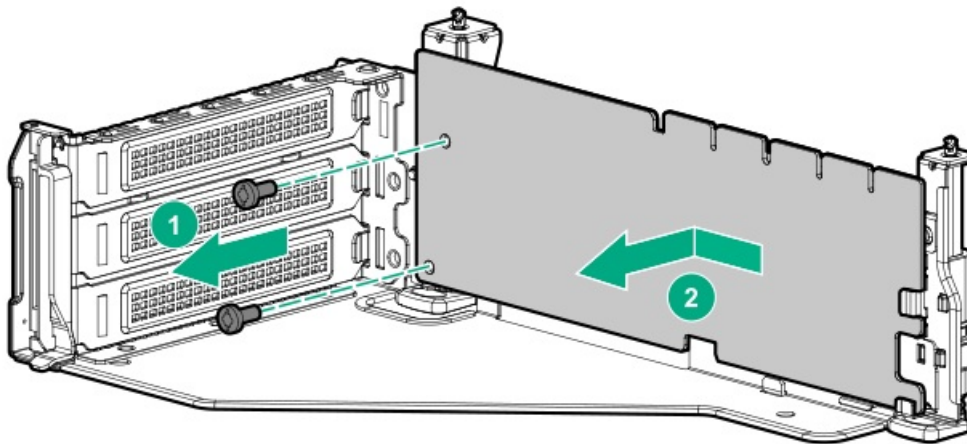

7. Install the riser.

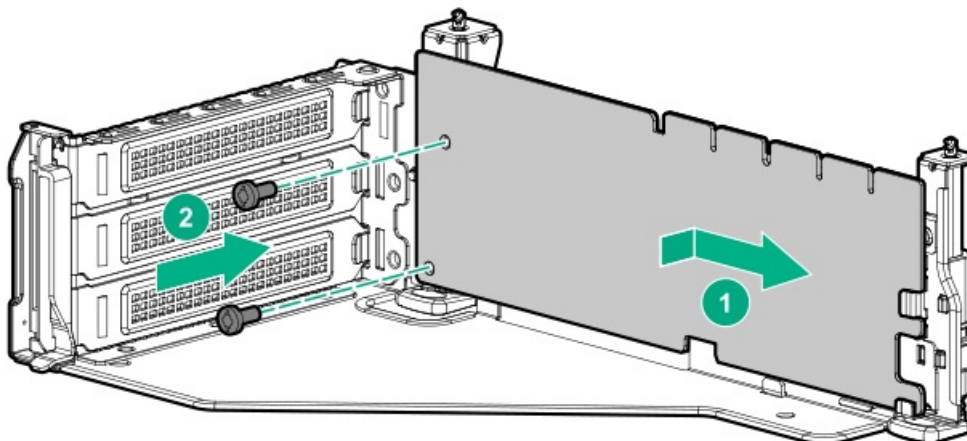

8. If needed, install an expansion board.



9. If needed, connect data cables to the riser or expansion board.

10. Install the riser cage:

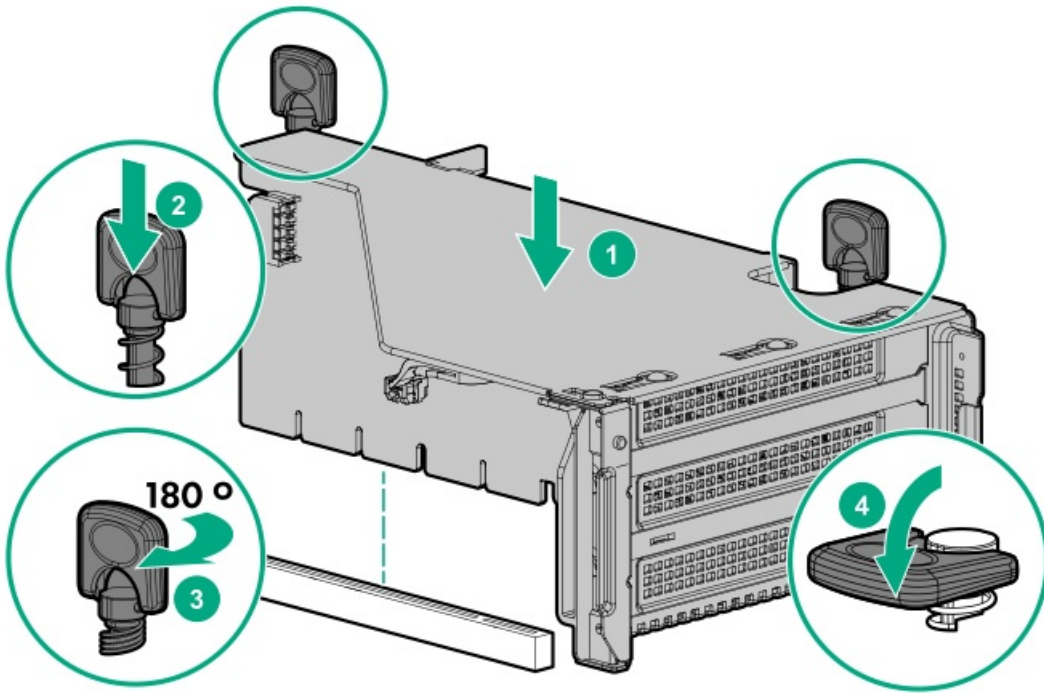

11. If needed, connect data cables to the drive backplane.

The installation is complete.

Installing tertiary risers

Prerequisites

Before you perform this procedure, make sure that you have the following items available:

- The components included with the hardware option kit
- T-10 Torx screwdriver
- A tertiary riser cage is required to install this option.

Procedure

1. Power down the server.
2. Do one of the following:
 - Disconnect each power cord from the power source.
 - Disconnect each power cord from the server.
3. Do one of the following:
 - Extend the server from the rack.
 - Remove the server from the rack.
4. Remove the access panel.
5. Remove the riser cage.
6. Install the riser.

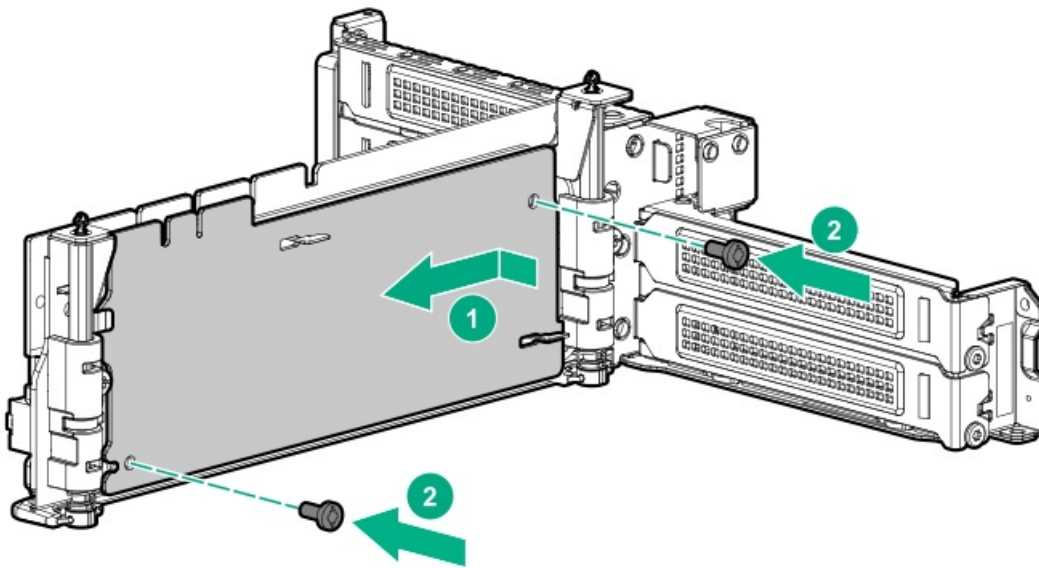

7. If needed, install an expansion board.
8. If needed, connect data cables to the riser or expansion board.
9. Install the tertiary riser cage:

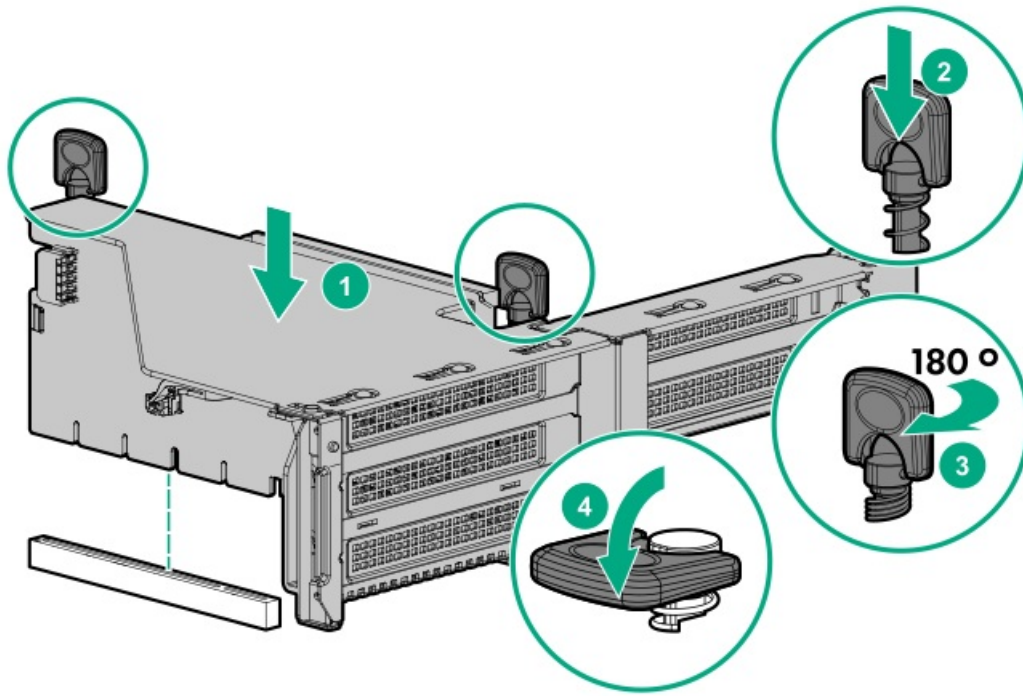

10. If needed, connect cables to drive backplane.

The installation is complete.

Installing a secondary riser cage

Prerequisites

Before you perform this procedure, make sure that you have the following items available:

- The components included with the hardware option kit
- T-10 Torx screwdriver

Procedure

1. Observe the following alert:

⚠ CAUTION: To prevent damage to the server or expansion boards, power down the server and remove all AC power cords before removing or installing the PCI riser cage.

2. Power down the server.
3. Remove all power:
 - a. Disconnect each power cord from the power source.
 - b. Disconnect each power cord from the server.
4. Do one of the following:
 - Extend the server from the rack.
 - Remove the server from the rack.
5. Remove the access panel.
6. Remove the rear wall blank.

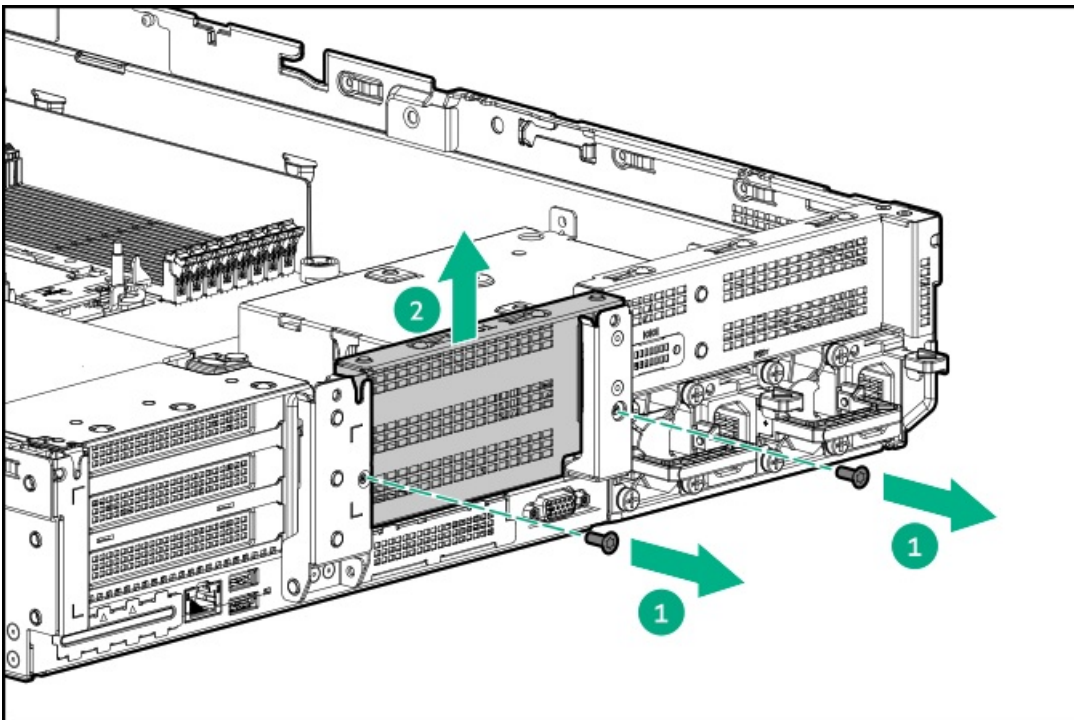

7. Install any expansion boards, if needed.
8. Install the riser cage:

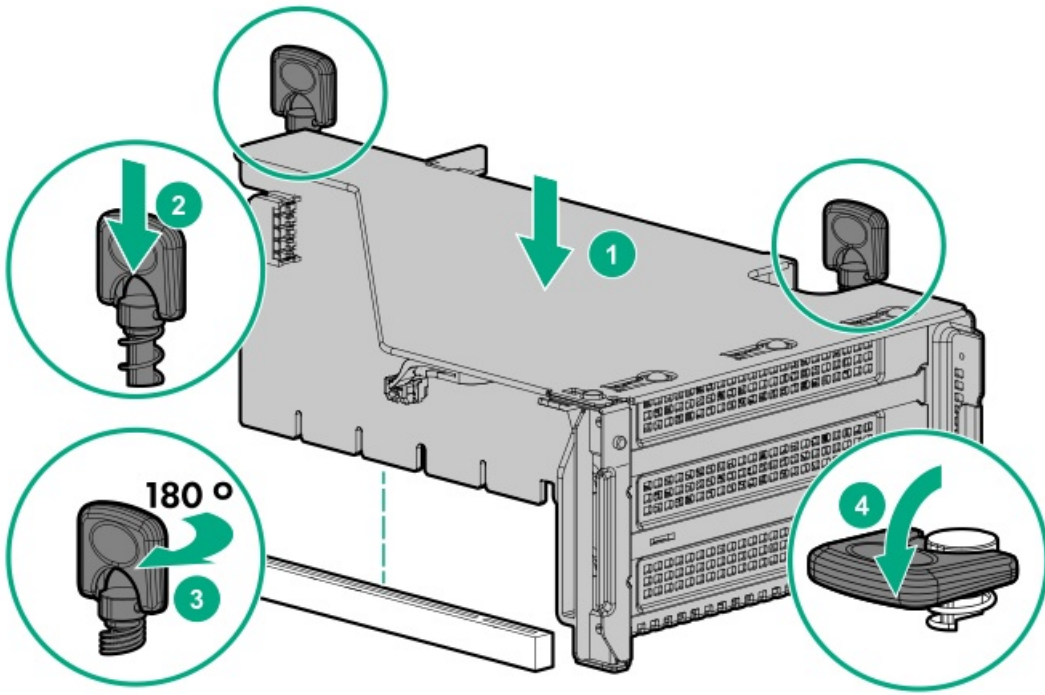

The installation is complete.

Installing a tertiary riser cage

Prerequisites

Before you perform this procedure, make sure that you have the following items available:

- The components included with the hardware option kit
- T-10 Torx screwdriver

Procedure

1. Observe the following alert.

⚠ CAUTION: To prevent damage to the server or expansion boards, power down the server and remove all AC power cords before removing or installing the PCI riser cage.

2. Power down the server.
3. Remove all power:
 - a. Disconnect each power cord from the power source.
 - b. Disconnect each power cord from the server.
4. Do one of the following:
 - Extend the server from the rack.
 - Remove the server from the rack.
5. Remove the access panel.
6. Remove the rear wall blanks.

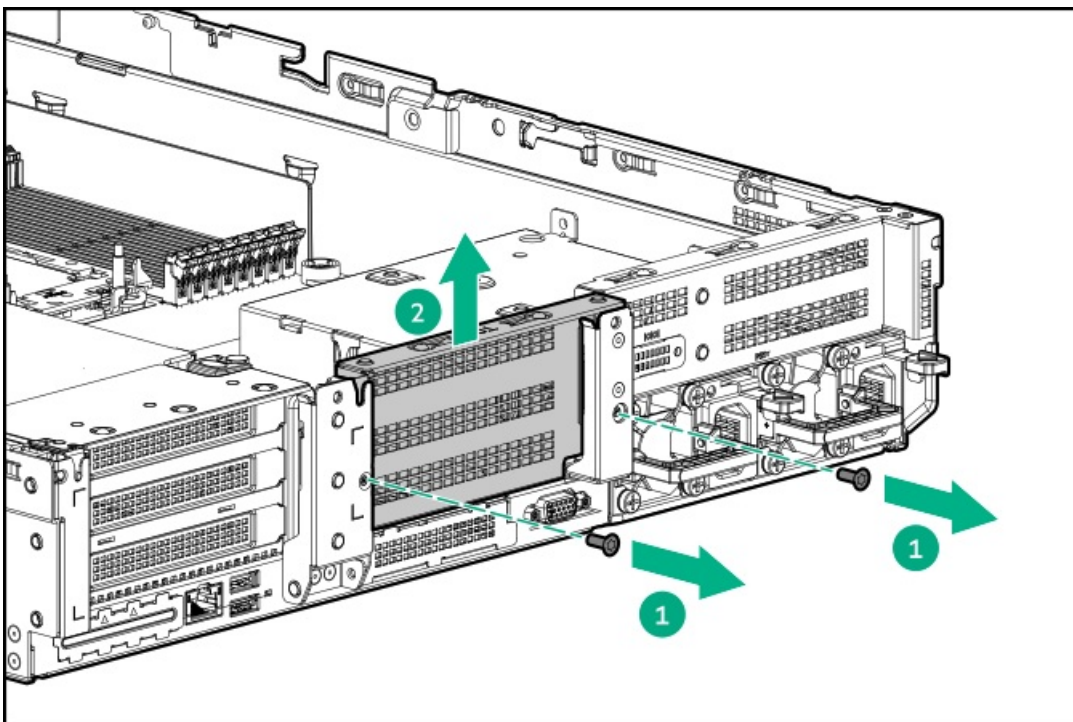

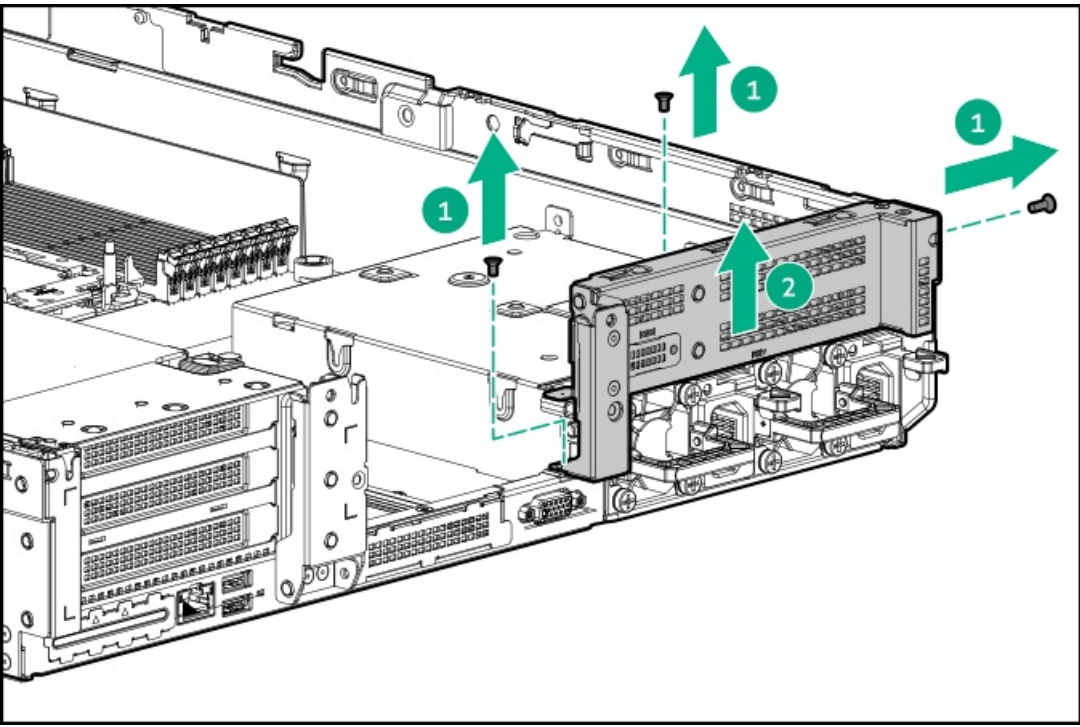

7. Install the rear blank from the option kit.

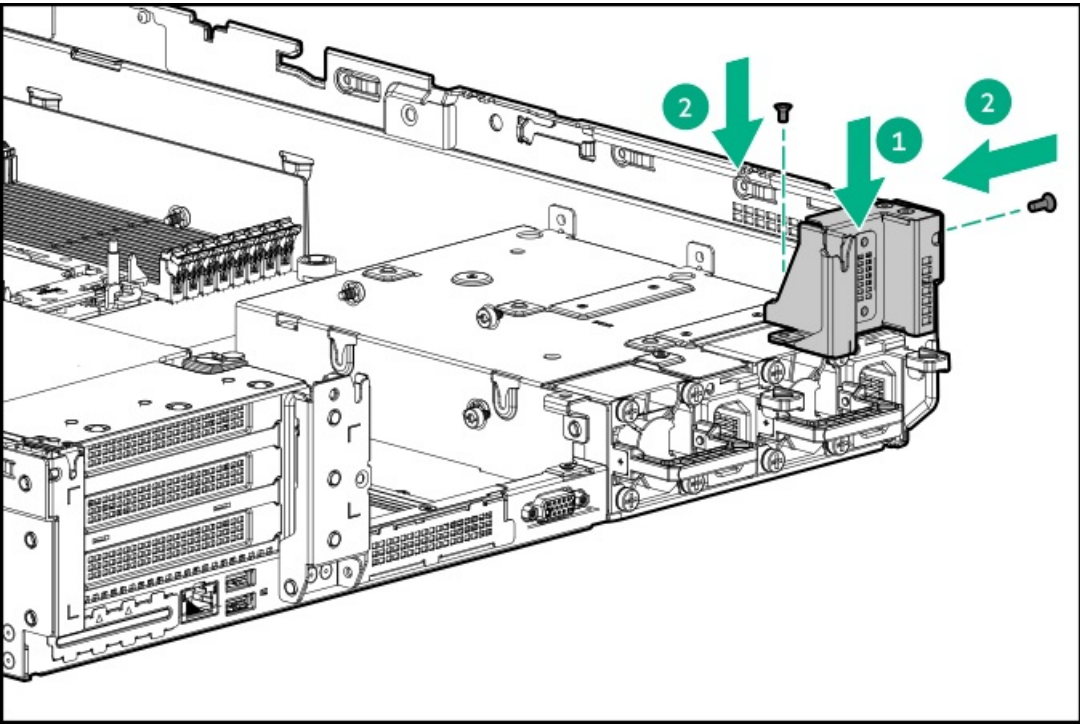

8. Install any expansion boards, if needed.

9. Install the tertiary riser cage:

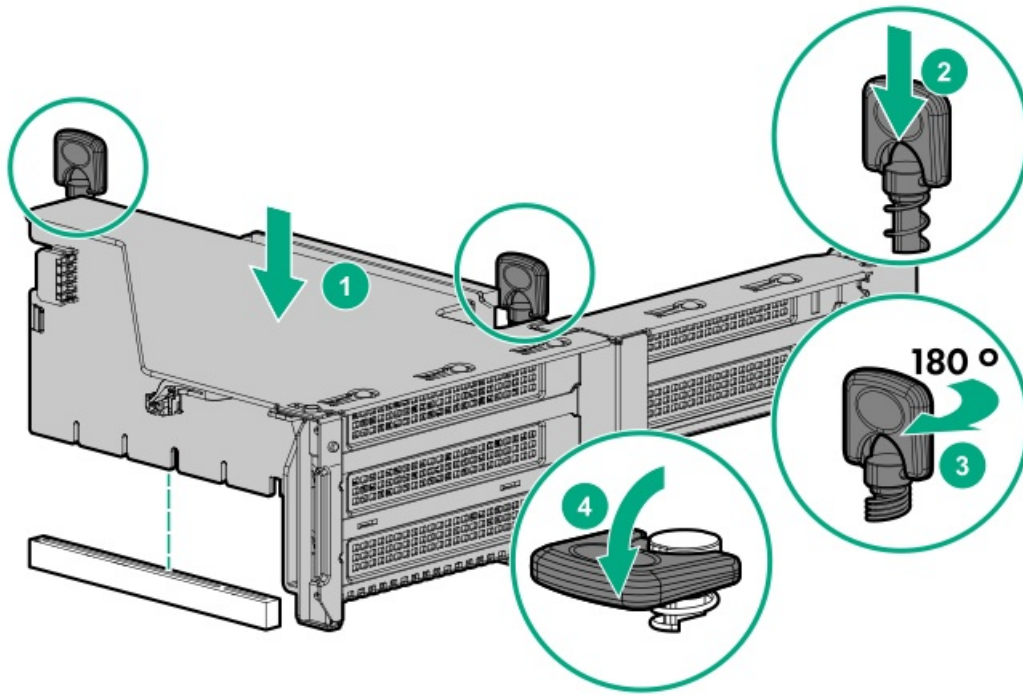

The installation is complete.



Supported PCIe form factors

All slots support full-height expansion cards. Use the following information to find supported lengths for each slot.

Slot description example

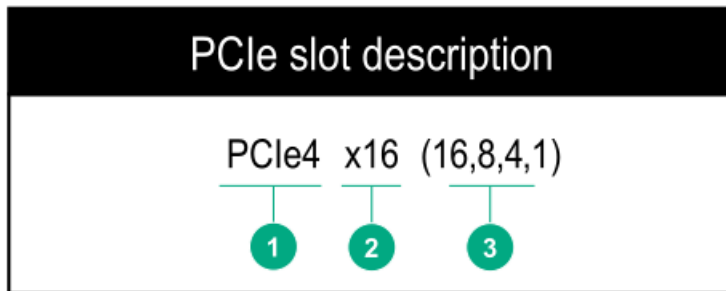

Primary riser connector

PCIe slot and card length	3-slot riser*	2-slot riser (Optional)	2-slot riser (Optional)
Slot 1 - Full-length/Full-height (FL/FH)	PCIe4 x8 (8, 4, 2, 1)	—	PCIe3 x16 (16, 8, 4, 2, 1)
Slot 2 - Full-length/Full-height (FL/FH)	PCIe4 x16 (16, 8, 4, 2, 1)	PCIe3 x16 (16, 8, 4, 2, 1)	PCIe3 x16 (16, 8, 4, 2, 1)
Slot 3 - Half-length/Full-height (HL/FH)	PCIe4 x8 (8, 4, 2, 1)	PCIe3 x16 (16, 8, 4, 2, 1)	—

*The server ships with one PCIe3 riser cage installed in the primary riser cage connector.

Secondary riser connector

PCIe slot and card length	3-slot riser*	2-slot riser (Optional)	2-slot riser (Optional)
Slot 4 - Full-length/Full-height (FL/FH)	PCIe3 x8 (8, 4, 2, 1)	—	PCIe3 x16 (16, 8, 4, 2, 1)
Slot 5 - Full-length/Full-height (FL/FH)	PCIe3 x16 (16, 8, 4, 2, 1)	PCIe3 x16 (16, 8, 4, 2, 1)	PCIe3 x16 (16, 8, 4, 2, 1)
Slot 6 - Half-length/Full-height (HL/FH)	PCIe3 x8 (8, 4, 2, 1)	PCIe3 x16 (16, 8, 4, 2, 1)	—

Tertiary riser connector

PCIe slot and card length	2-slot riser (Optional)	1-slot riser (Optional)
Slot 7 - Full-length/Full-height (FL/FH)	PCIe3 x8 (8, 4, 2, 1)	PCIe3 x16 (16, 8, 4, 2, 1)
Slot 8 - Half-length/Full-height (HL/FH)	PCIe3 x8 (8, 4, 2, 1)	—

Installing expansion boards

WARNING: To reduce the risk of personal injury, electric shock, or damage to the equipment, remove the power cord to remove power from the server. The front panel Power On/Standby button does not shut off system power. Portions of the power supply and some internal circuitry remain active until AC power is removed.

CAUTION: To prevent improper cooling or thermal damage, do not operate the server unless all PCI slots have either an expansion slot cover or an expansion board installed.

To install the component:

Prerequisites

Before you perform this procedure, make sure that you have the following items available:

The components included with the hardware option kit

Procedure

1. Power down the server.
2. Remove all power:
 - a. Disconnect each power cord from the power source.
 - b. Disconnect each power cord from the server.
3. Do one of the following:
 - Extend the server from the rack.
 - Remove the server from the rack.
4. Remove the access panel.
5. Remove the riser cage.

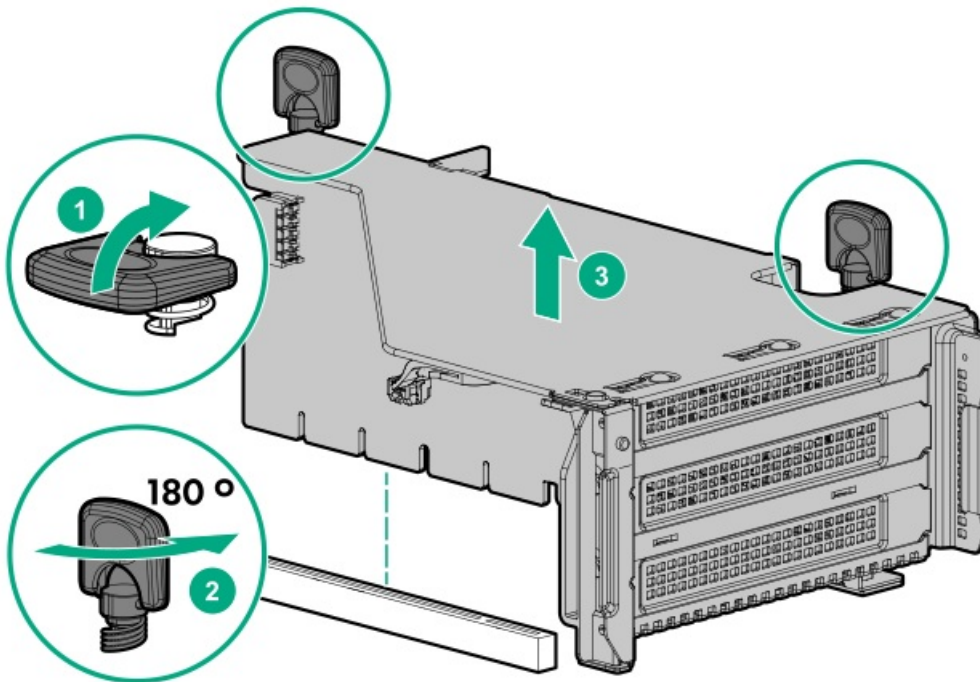

6. Identify and then remove the PCIe blank from the riser cage.

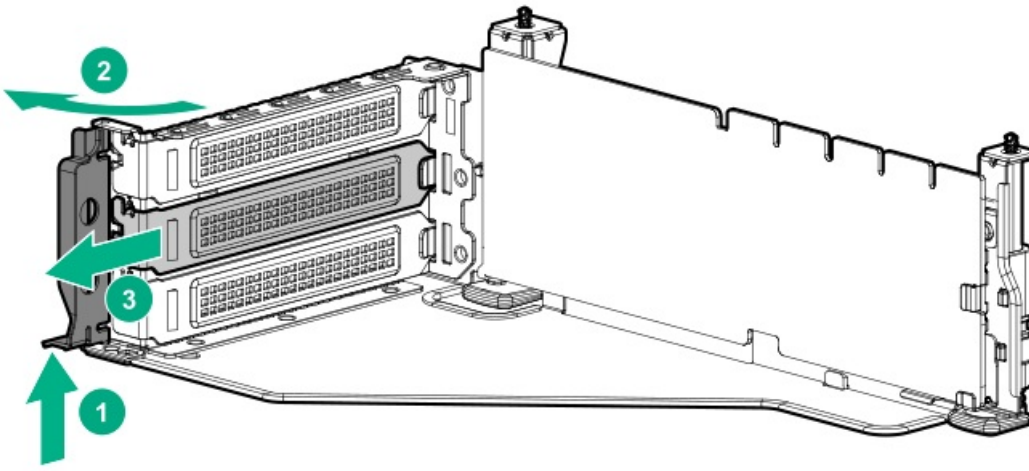

7. Install the expansion board.

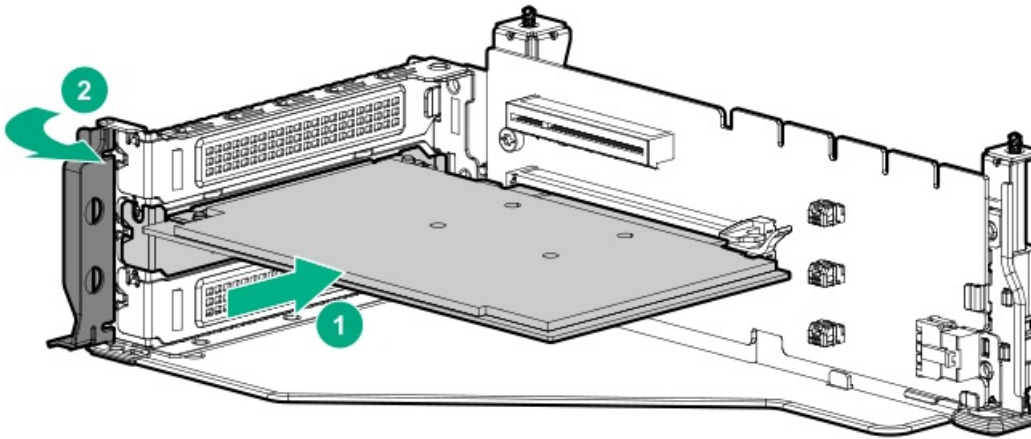

8. If internal cables are required for the expansion board, connect the cables.

9. Install the riser cage.

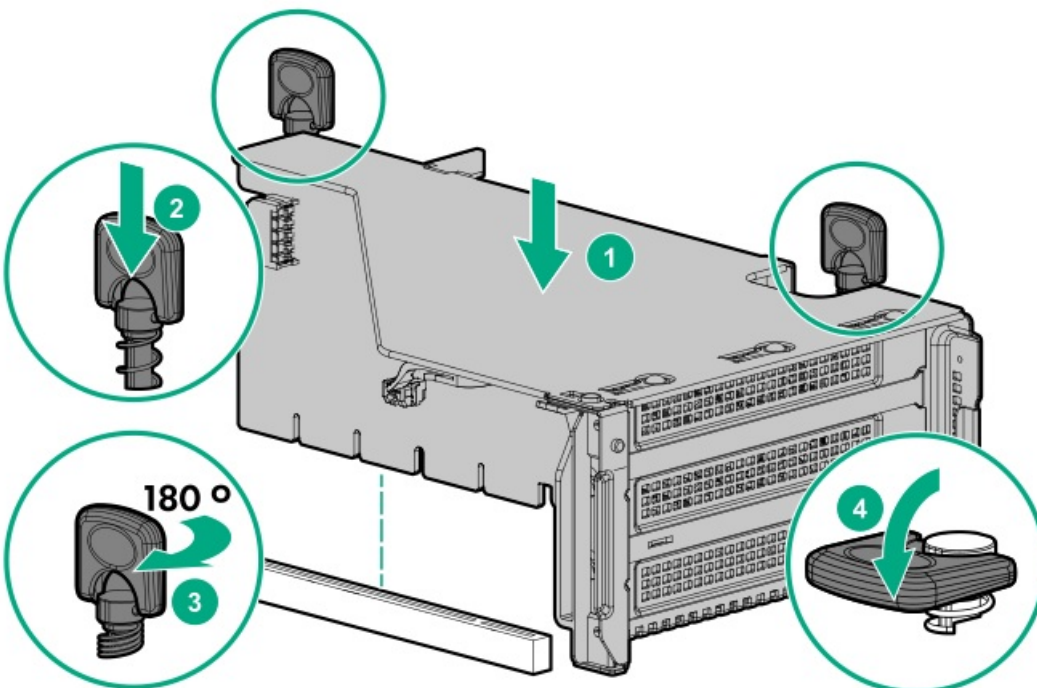

10. Install the access panel.



11. Slide the server into the rack.
12. Connect each power cord to the server.
13. Connect each power cord to the power source.
14. Power up the server.

The installation is complete.



Accelerator options

This server supports various accelerator options to meet your computational and graphics workload requirements. For a list of supported accelerator models, see the server QuickSpecs on the Hewlett Packard Enterprise website (<https://www.hpe.com/info/qs>).

- PCIe workload accelerators – These options are PCIe card-based, direct-attach solutions that use solid-state storage technology directly on the PCI bus to boost I/O performance and reduce latency to scale in line with your processing requirements.
- Computational and graphics accelerators – These options deliver accelerated compute performance for a range of deep learning, high-performance computing (HPC), and graphics-intensive applications.

Installing an accelerator or GPU

An accelerator or GPU can be installed into the primary, secondary, or tertiary position. This procedure shows an installation in the secondary position.

Prerequisites

Before you perform this procedure, make sure that you have the following items available:

- The components included with the hardware option kit
- T-30 Torx screwdriver
- T-10 Torx screwdriver
- High-performance heatsinks must be installed with this option.

Procedure

1. Observe the following alert.

△ CAUTION: To prevent improper cooling and thermal damage, do not operate the server unless all PCIe slots have either an expansion slot cover or an expansion board installed.

2. [Power down the server.](#)
3. Remove all power:
 - a. Disconnect each power cord from the power source.
 - b. Disconnect each power cord from the server.
4. Do one of the following:
 - [Extending the server from the rack.](#)
 - [Removing the server from the rack.](#)
5. [Remove the access panel.](#)
6. [Removing the air baffle or midplane drive cage.](#)
7. Install the appropriate retention clip onto the air baffle.

Install the clip that supports your configuration. Primary, secondary, and tertiary positions are shown.

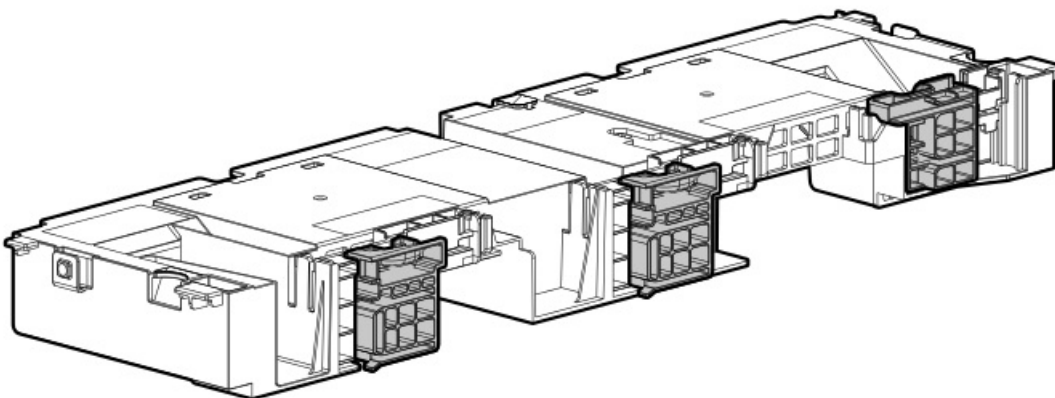

8. [Install high-performance heatsinks.](#)
9. [Install the air baffle.](#)
10. Remove the rear wall blank.

The secondary rear wall blank is shown.

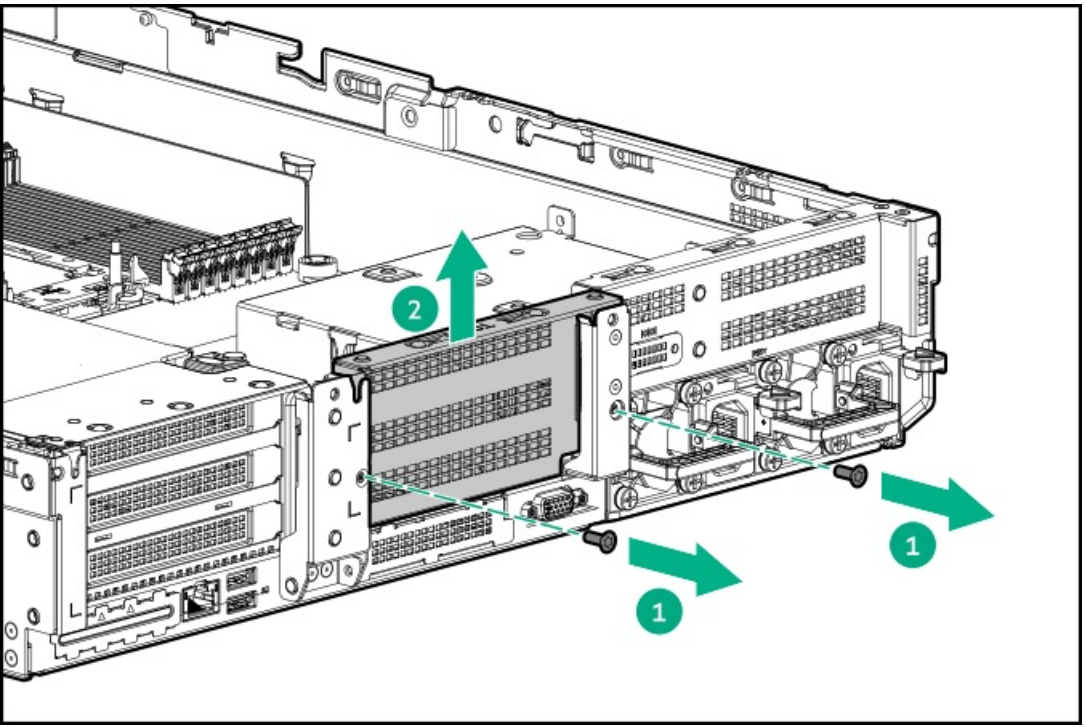

To install a riser card in the primary riser cage, see "[Removing a riser cage](#)".

To install a riser card in the tertiary riser cage, see "[Installing tertiary risers](#)".

11. Remove the PCIe blank.

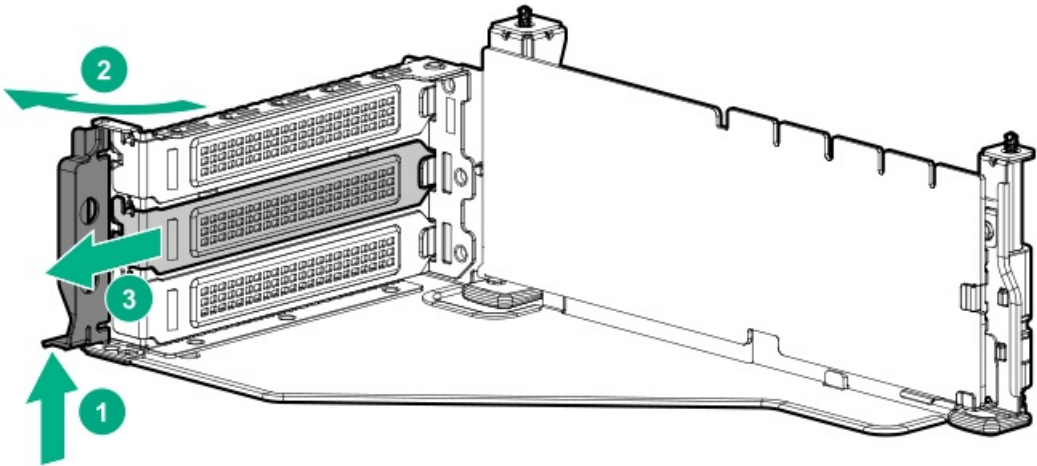

12. Install the card into the riser.

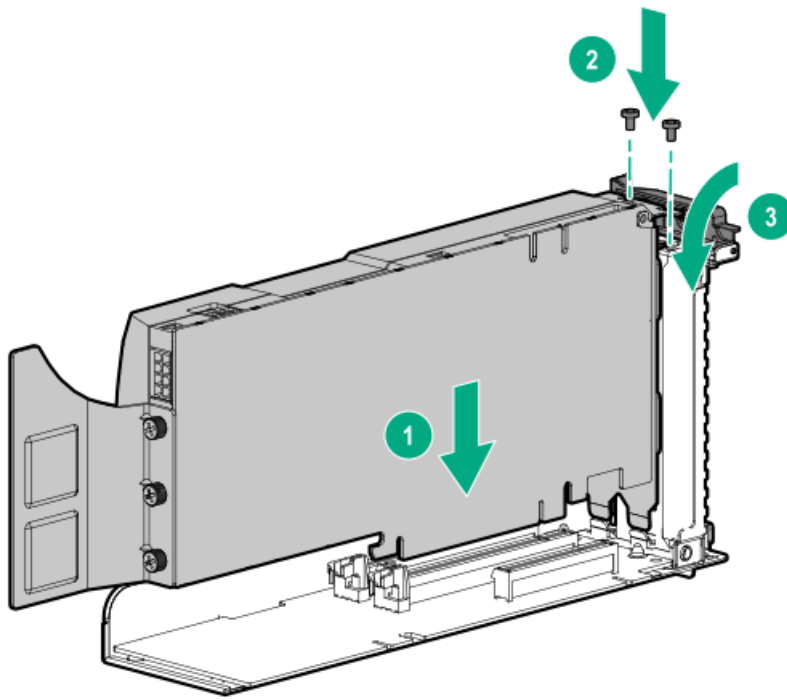

13. If required, connect the power cable from the card to the riser.
14. For full-length cards, open the retention clips.

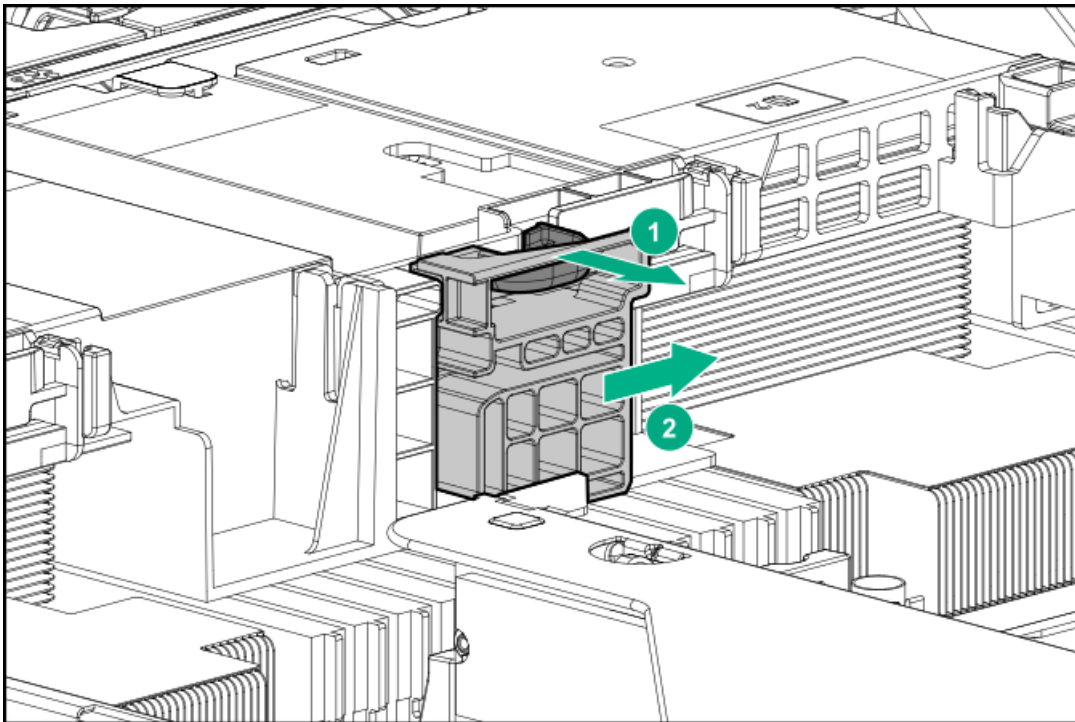

15. Install the riser cage.



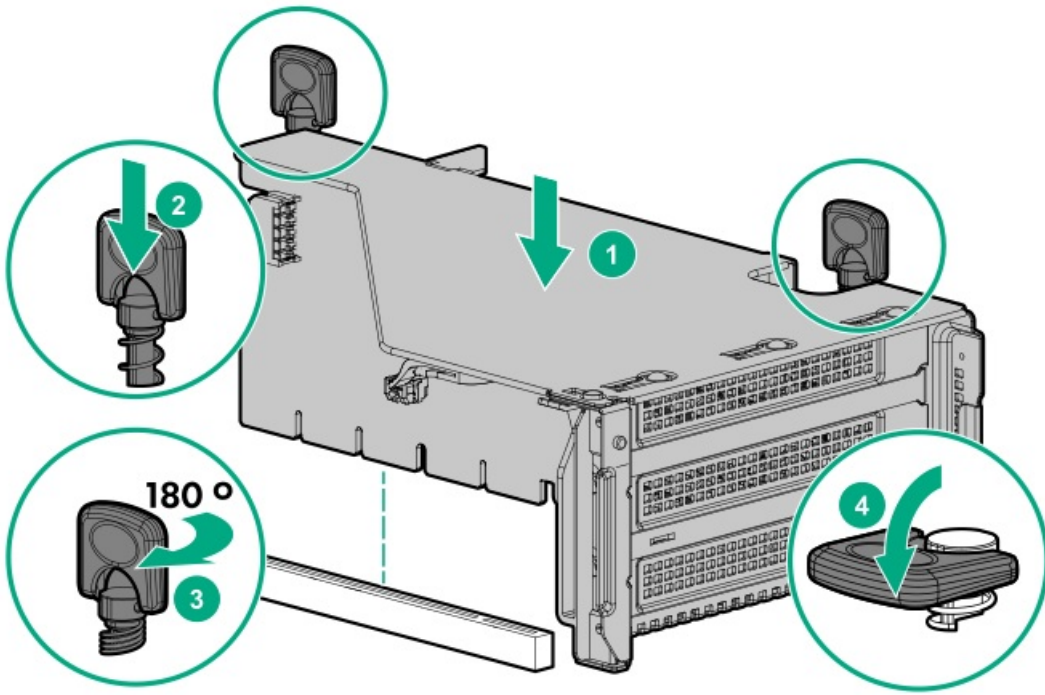

16. For full-length cards, slide the retention clips to the locked position.

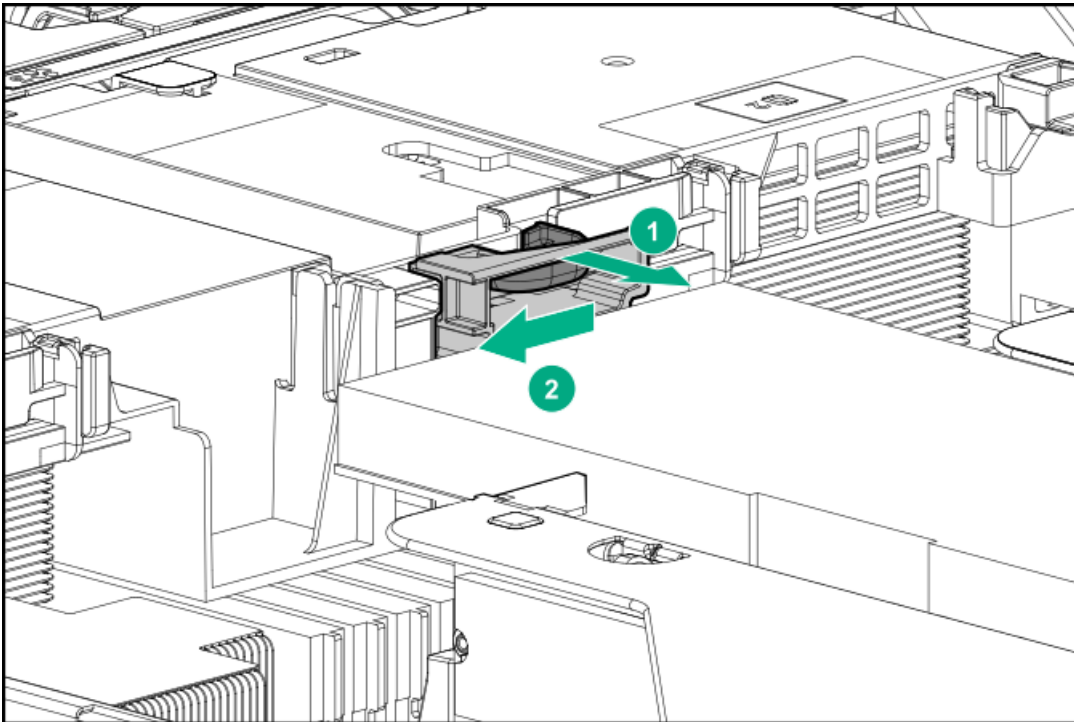

The installation is complete.





Installing a front 8NVMe drive cage

The drive cage can be installed in any box. This procedure covers installing the drive cage in box 1.

Prerequisites

High-performance fans are required when installing this option.

Procedure

1. Observe the following alerts.

WARNING: To reduce the risk of personal injury from hot surfaces, allow the drives and the internal system components to cool before touching them.

△ **CAUTION:** To prevent damage to electrical components, properly ground the server before beginning any installation procedure. Improper grounding can cause ESD.

2. Power down the server.
3. Do one of the following:
 - Extend the server from the rack.
 - Remove the server from the rack.
4. Remove the access panel.
5. Remove the air baffle.
6. Remove the fan cage.
7. Remove the blank.

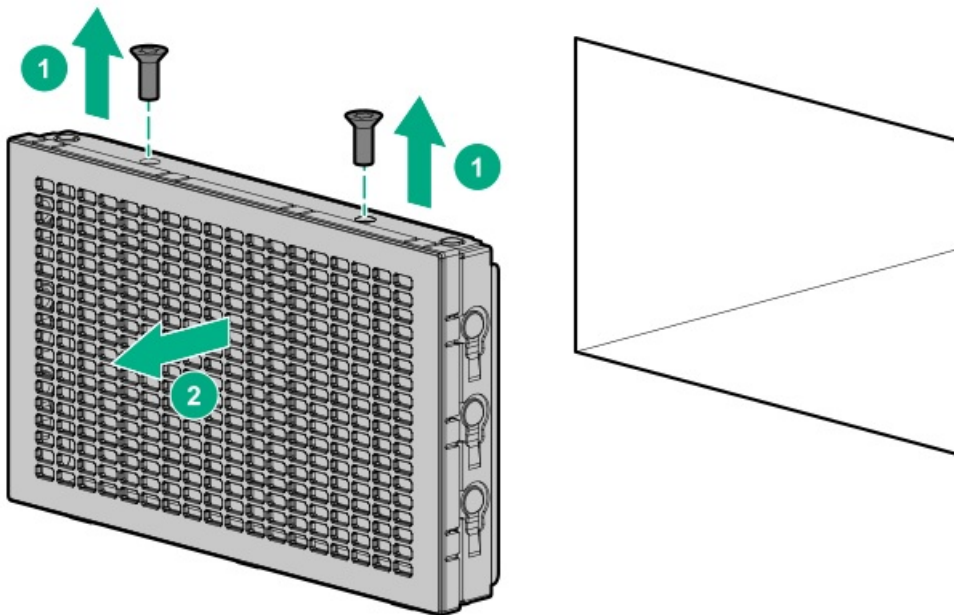

8. Install the drive cage:
 - a. Remove all drive blanks.
 - b. Install the drive cage.

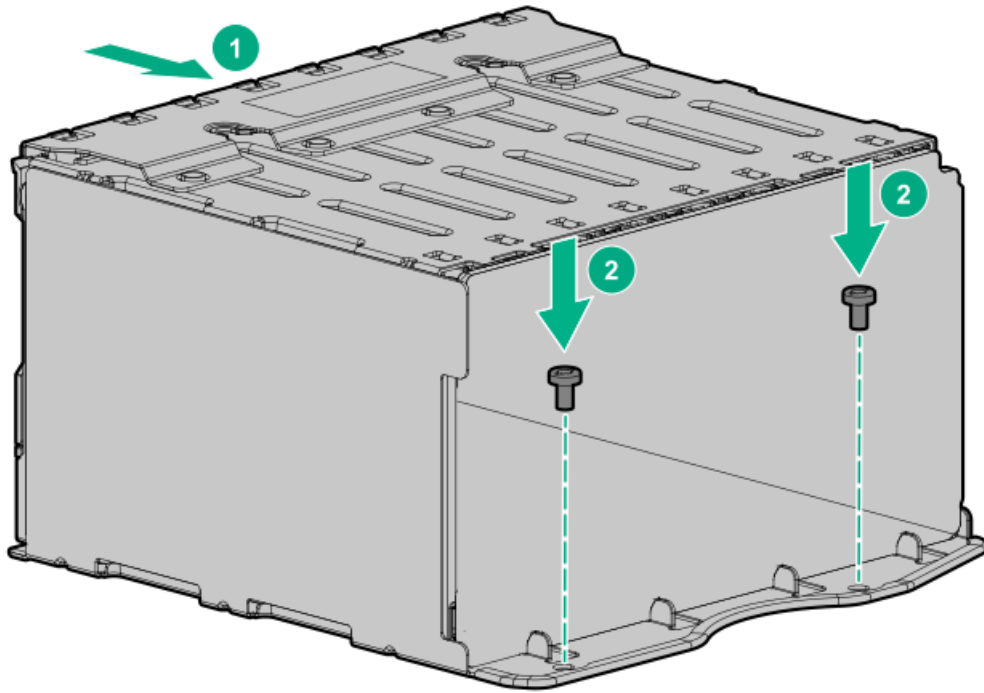

9. Install the associated NVMe riser.
10. Connect the power cable to the drive backplane power connector .
11. Connect the data cables from the drive backplane to the NVMe riser.
12. Install drives or drive blanks.

The installation is complete.

Installing a front 8 SFF SAS/SATA drive cage in box 1

Prerequisites

Before you perform this procedure, make sure that you have the following items available:

- T-15 Torx screwdriver
- The components included with the hardware option kit

Procedure

1. Power down the server.
2. Remove all power:
 - a. Disconnect each power cord from the power source.
 - b. Disconnect each power cord from the server.
3. Do one of the following:
 - Extend the server from the rack.
 - Remove the server from the rack.
4. Remove the access panel.
5. Remove the air baffle.
6. Remove the fan cage.
7. Remove the bay blank.

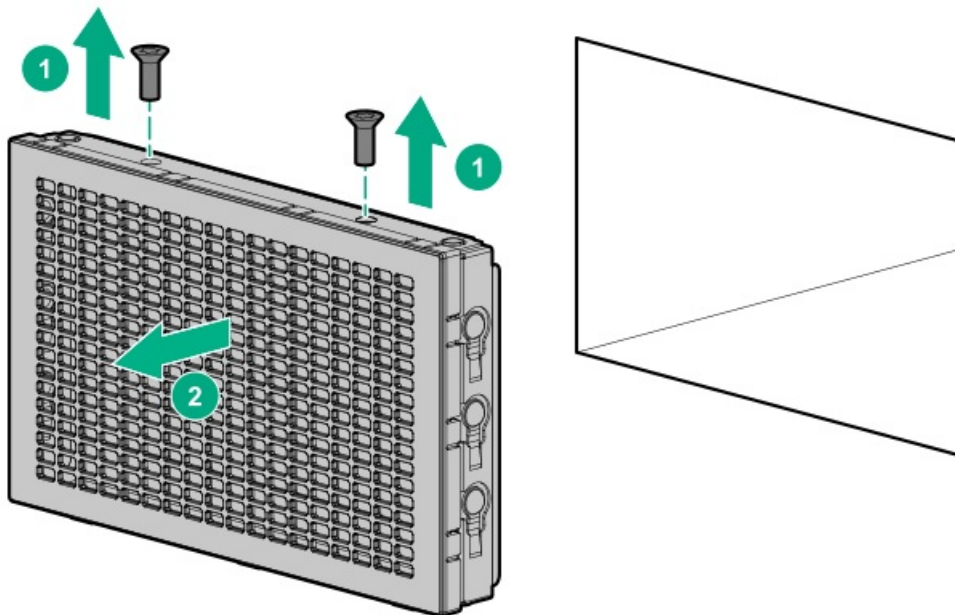

8. Install the 8 SFF front drive cage option.

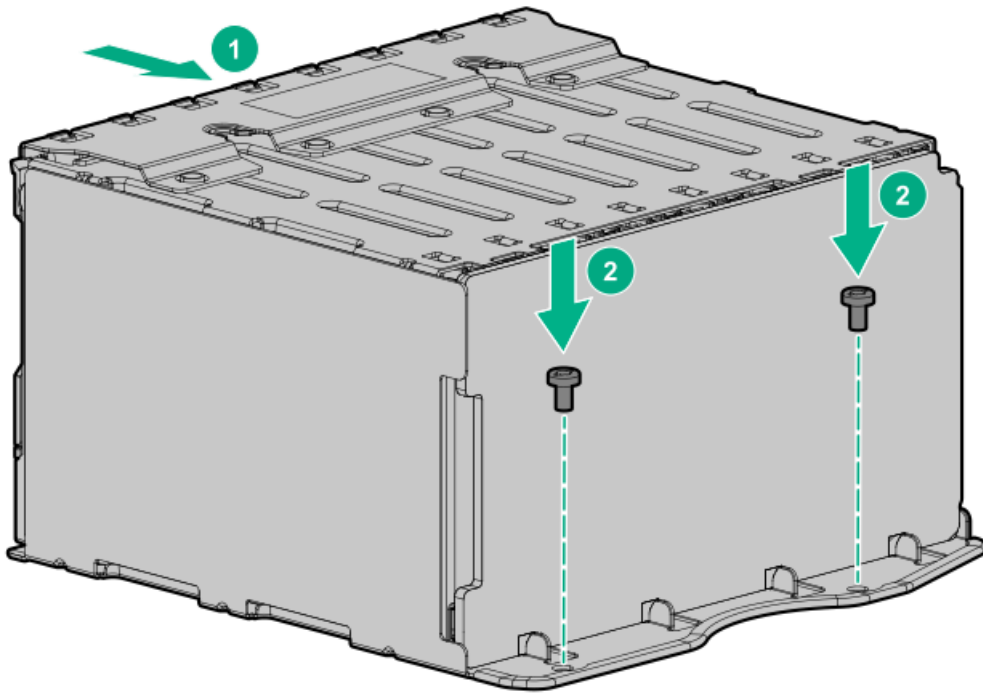

9. Connect the power and data cables.
10. Install the fan cage.
11. Install the air baffle.
12. Install the access panel.
13. Slide the server into the rack.
14. Connect each power cord to the server.
15. Connect each power cord to the power source.
16. Power up the server.

Installing a front 8 SFF SAS/SATA drive cage in box 2

Prerequisites

Before you perform this procedure, make sure that you have the following items available:

- T-15 Torx screwdriver
- The components included with the hardware option kit

Procedure

1. Power down the server.
2. Remove all power:
 - a. Disconnect each power cord from the power source.
 - b. Disconnect each power cord from the server.
3. Do one of the following:
 - Extend the server from the rack.
 - Remove the server from the rack.
4. Remove the access panel.
5. Remove the air baffle.
6. Remove the fan cage.
7. Remove the bay blank.

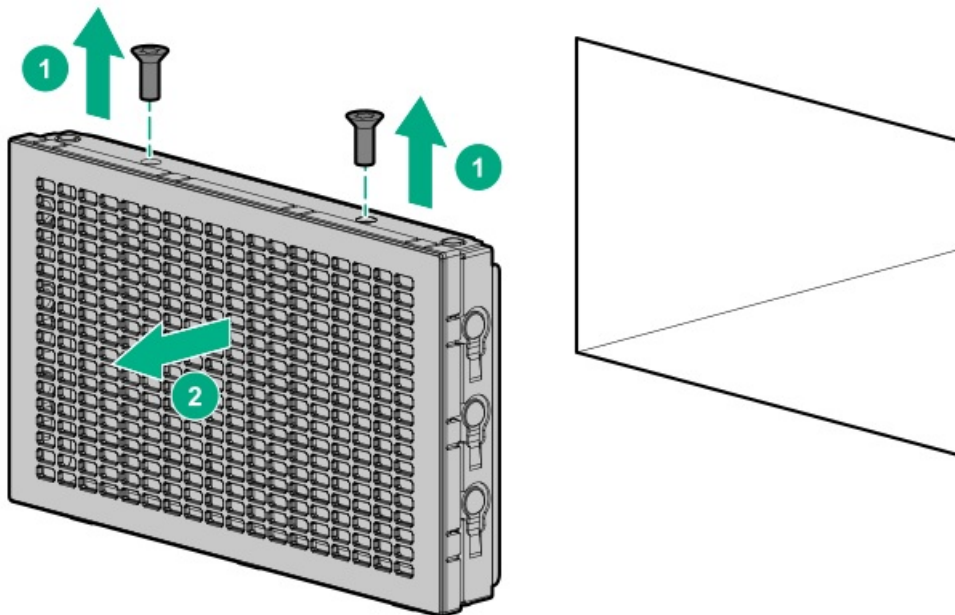

8. Install the 8 SFF front drive cage option.

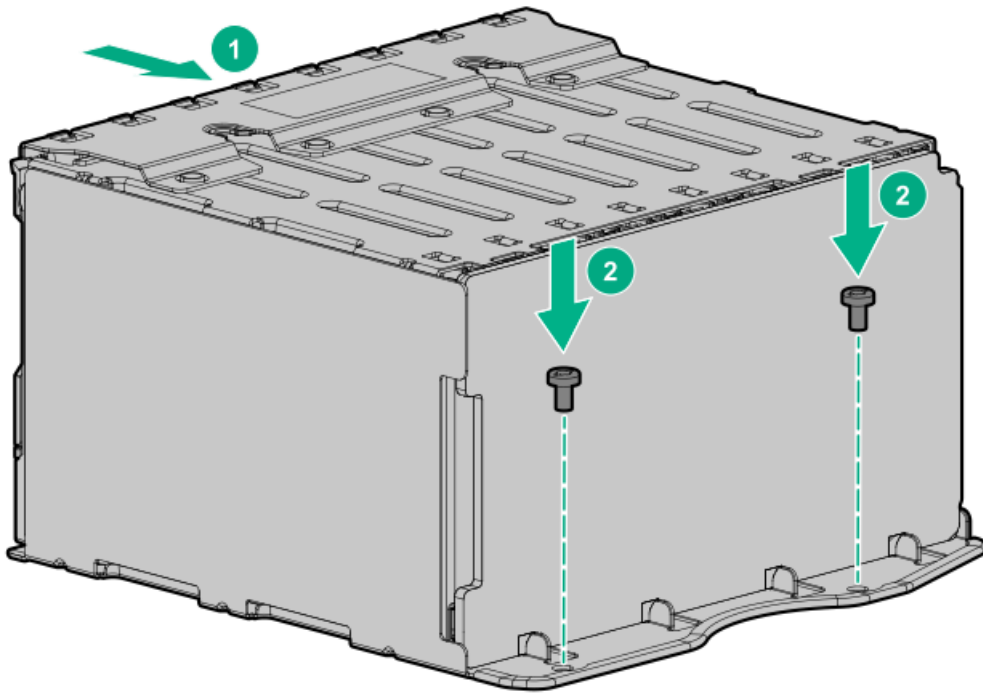

9. Connect the power and data cables.
10. Install the fan cage.
11. Install the access panel.
12. Slide the server into the rack.
13. Connect each power cord to the server.
14. Connect each power cord to the power source.
15. Power up the server.

Installing a front/tertiary 2 SFF NVMe/SAS/SATA stackable drive cage

Prerequisites

Before you perform this procedure, make sure that you have the following items available:

- T-10 Torx screwdriver
- The components included with the hardware option kit
- This installation requires a universal media bay.

Procedure

1. Power down the server.
2. Remove all power:
 - a. Disconnect each power cord from the power source.
 - b. Disconnect each power cord from the server.
3. Do one of the following:
 - Extend the server from the rack.
 - Remove the server from the rack.
4. Remove the access panel.
5. Remove the front bay blank.

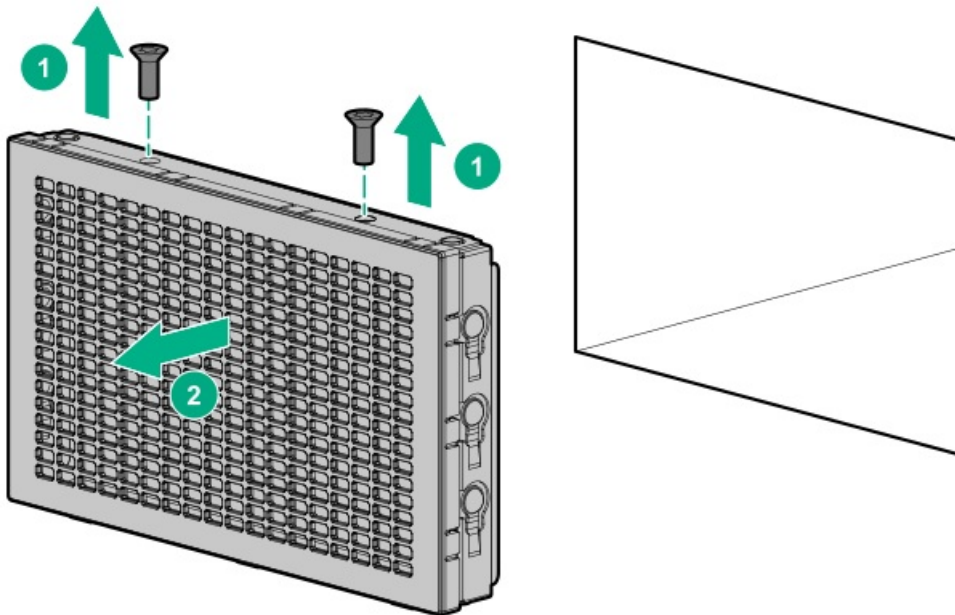

6. Remove the optical disc drive tray from the universal media bay.

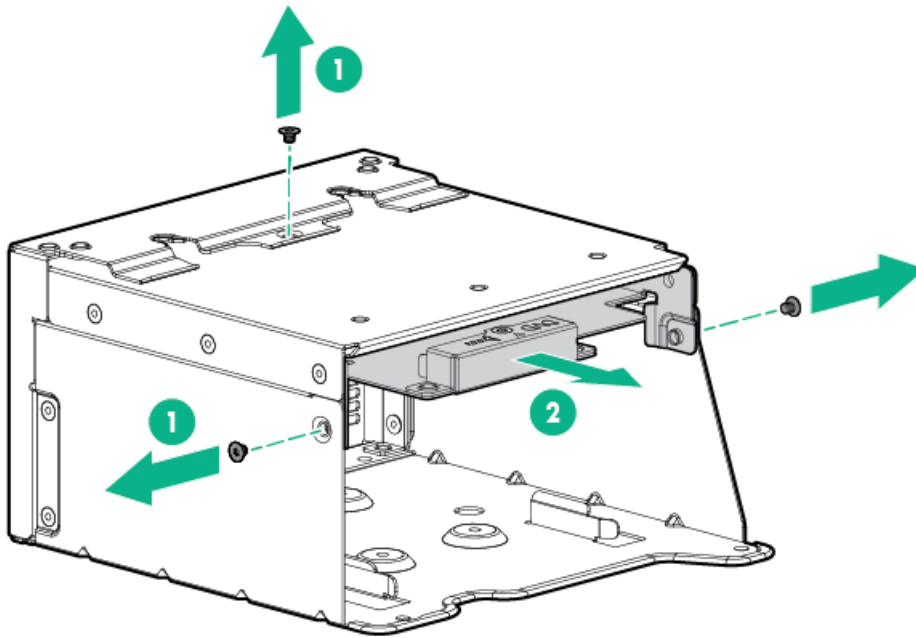

7. Remove the SFF drive blank from the universal media bay.

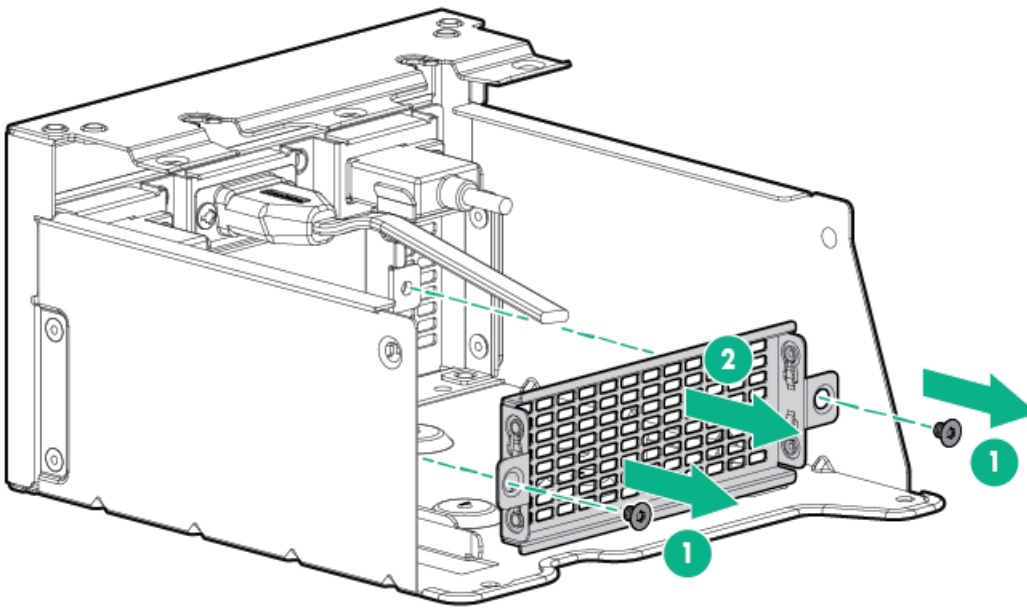

8. Install the drive cage into the universal media bay.



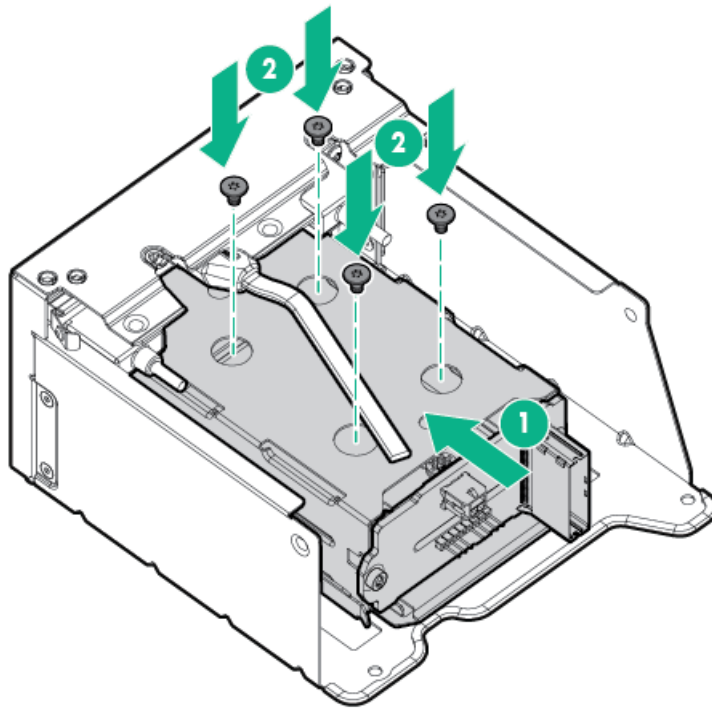

9. Install the optical disc drive tray.

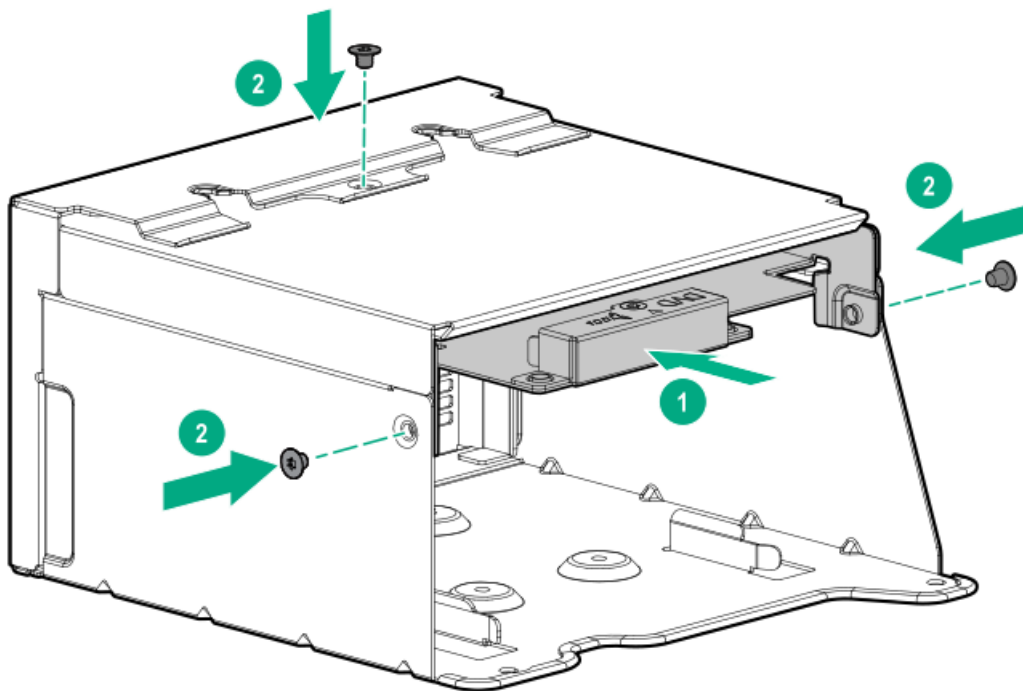

10. Install the Universal Media Bay.
11. Connect the power and data cables.
12. Install the access panel.
13. Slide the server into the rack.
14. Connect each power cord to the server.
15. Connect each power cord to the power source.
16. Power up the server.

Installing a midplane drive cage

Observe the following:

- A 1U heatsink is required for each processor when installing this option.
- If you have a TPM, install it prior to this option.
- If you have a type-a controller, install it prior to this option.

Prerequisites

Before you perform this procedure, make sure that the components included with the hardware option kit are available.

Procedure

1. Power down the server.
2. Remove all power:
 - a. Disconnect each power cord from the power source.
 - b. Disconnect each power cord from the server.
3. Do one of the following:
 - Extend the server from the rack.
 - Remove the server from the rack.
4. Remove the access panel.
5. Remove the air baffle.

The air baffle is no longer needed. The drive cage acts as an air baffle for the server.

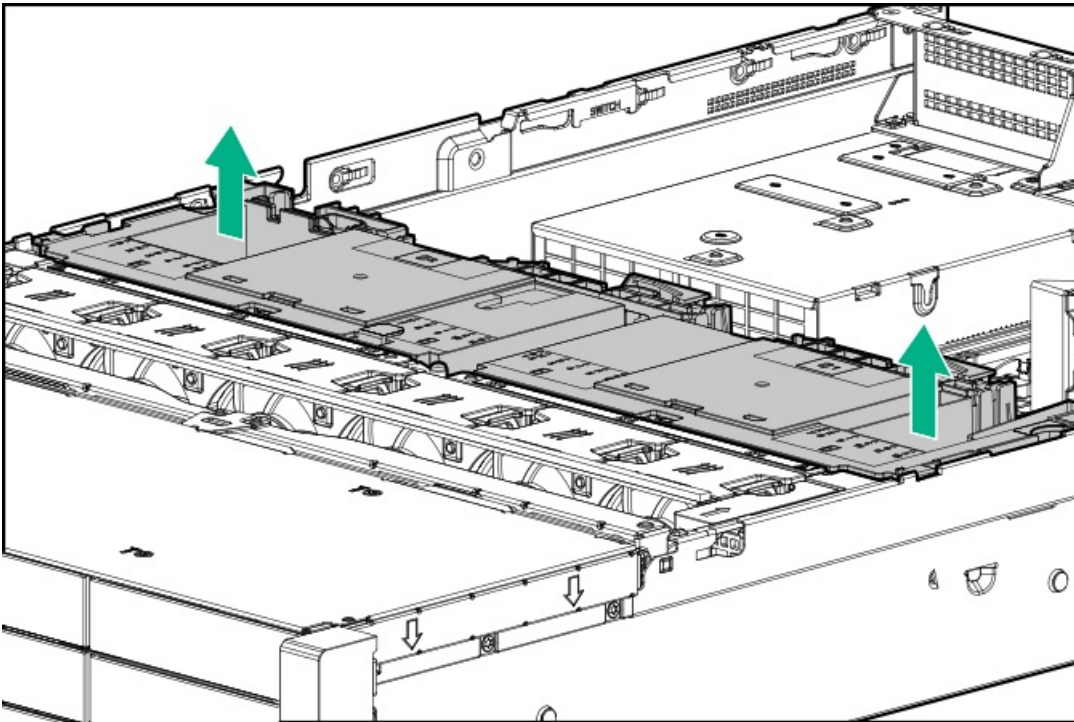

6. Remove all riser cages.

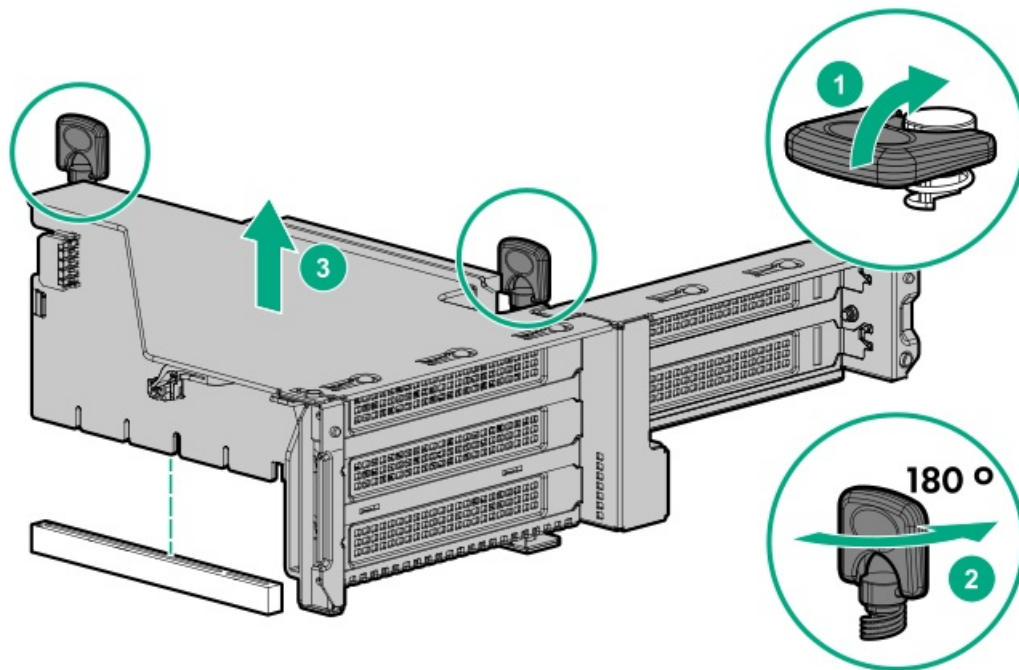
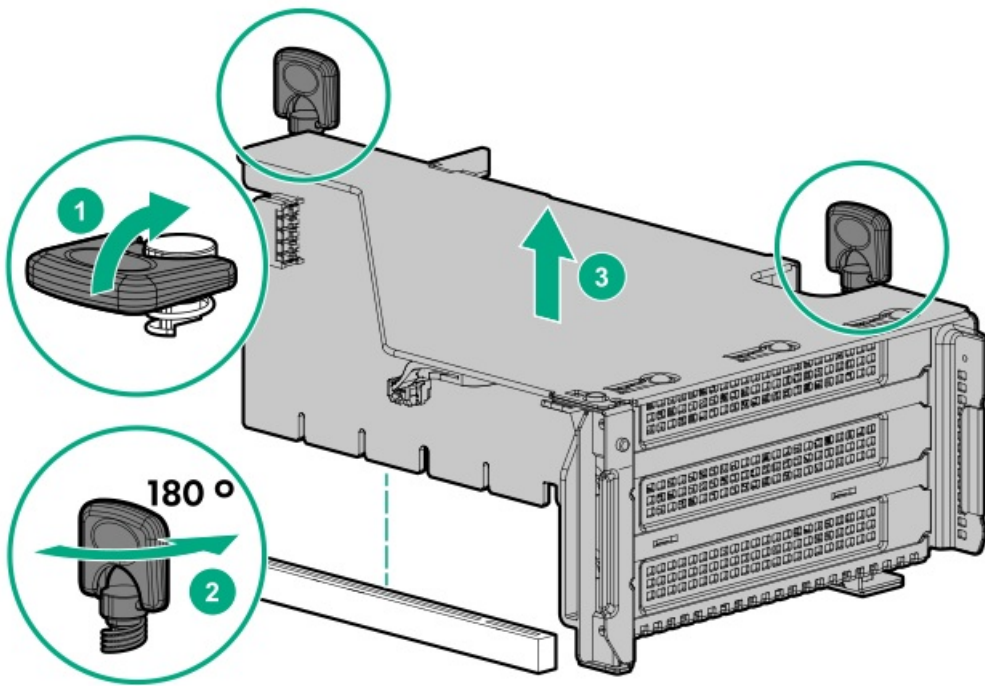

7. Connect the power cable to the drive backplane power connector on the system board.
8. If connecting the data cable to the system board or a controller, connect the data cable.
9. Prepare the drive cage for installation by lifting the latches on the drive cage.
10. Install the drive cage:

CAUTION: Do not drop the drive cage on the system board. Dropping the drive cage on the system board might damage the system or components. Remove all drives and use two hands when installing or removing the drive cage.

- a. Locate the alignment pins on the rear of the drive cage.
- b. Align the pin on the rear left of the drive cage to the server and then insert the pin.
- c. Gently lower the opposite side of the drive cage.
- d. Pull the plunger pin on the rear right of the drive cage and then lower the drive cage until the plunger pin engages.

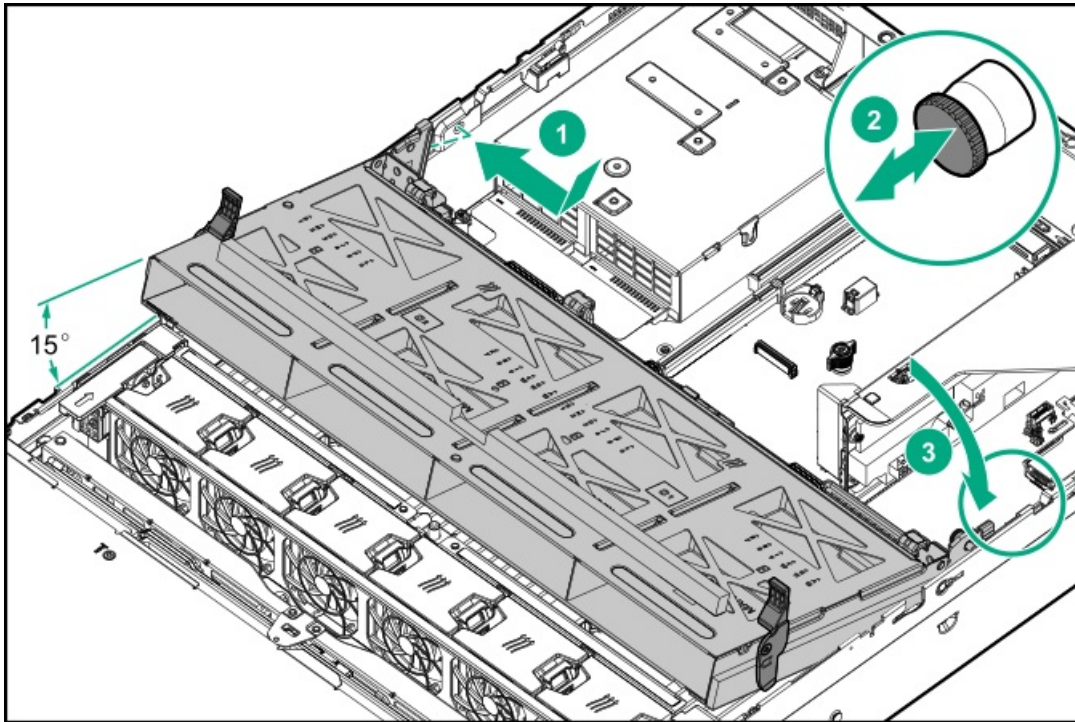

11. Install drives or drive blanks.
12. Push down on the latches to lower the drive cage into place.

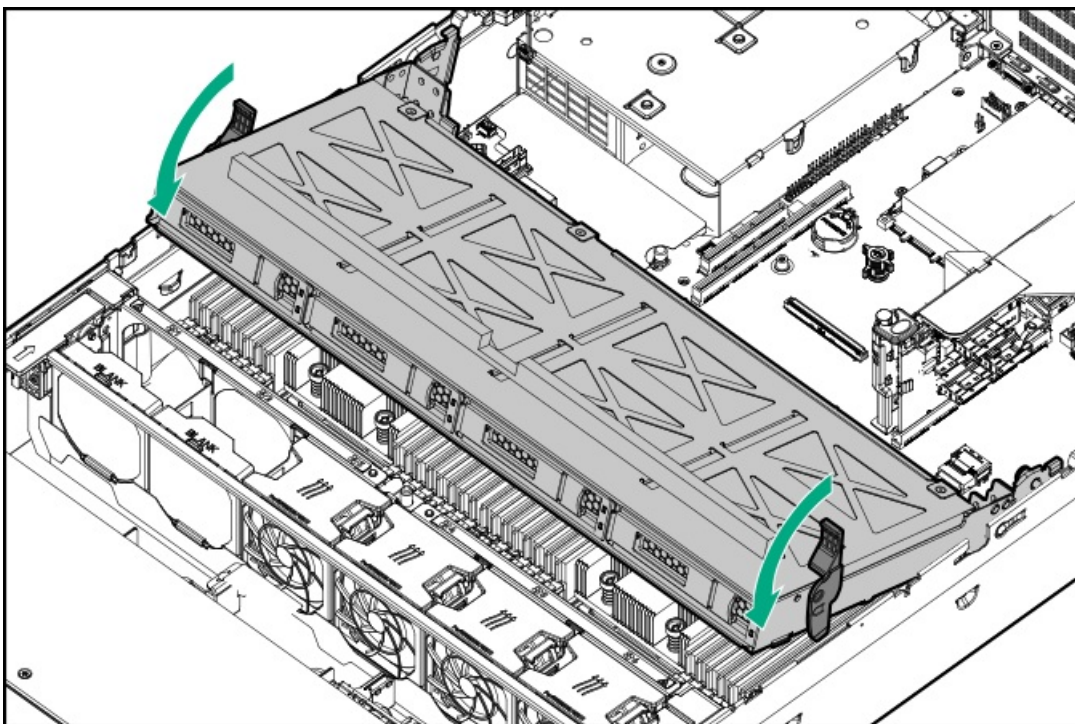

13. Connect the power and data cables to the drive backplane.

Installing a rear 2 SFF SAS/SATA drive cage in the primary or secondary riser

Prerequisites

-

Before you perform this procedure, make sure that you have the following items available:

- T-10 Torx screwdriver
- The components included with the hardware option kit
- The front drive bays are fully populated with 12 LFF or 24 SFF drives.
- High-performance fans are installed in all fan bays.

Procedure

1. Power down the server.
2. Remove all power:
 - a. Disconnect each power cord from the power source.
 - b. Disconnect each power cord from the server.
3. Do one of the following:
 - Extend the server from the rack.
 - Remove the server from the rack.
4. Remove the access panel.
5. Do one of the following:
 - For primary bays, remove the riser cage.

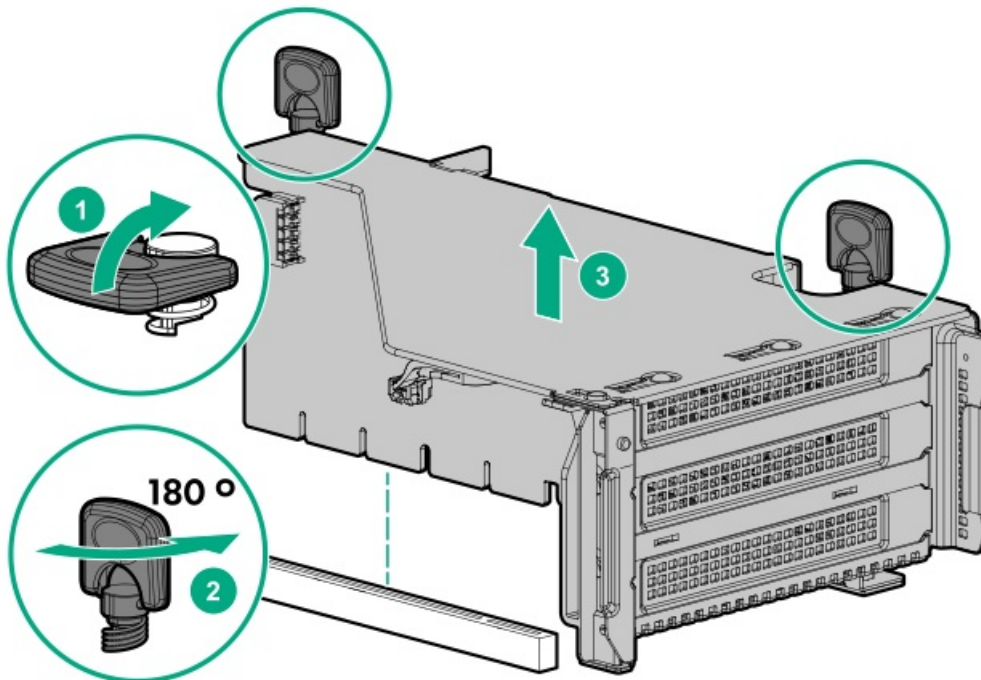

- For secondary bays, remove the rear wall blank.

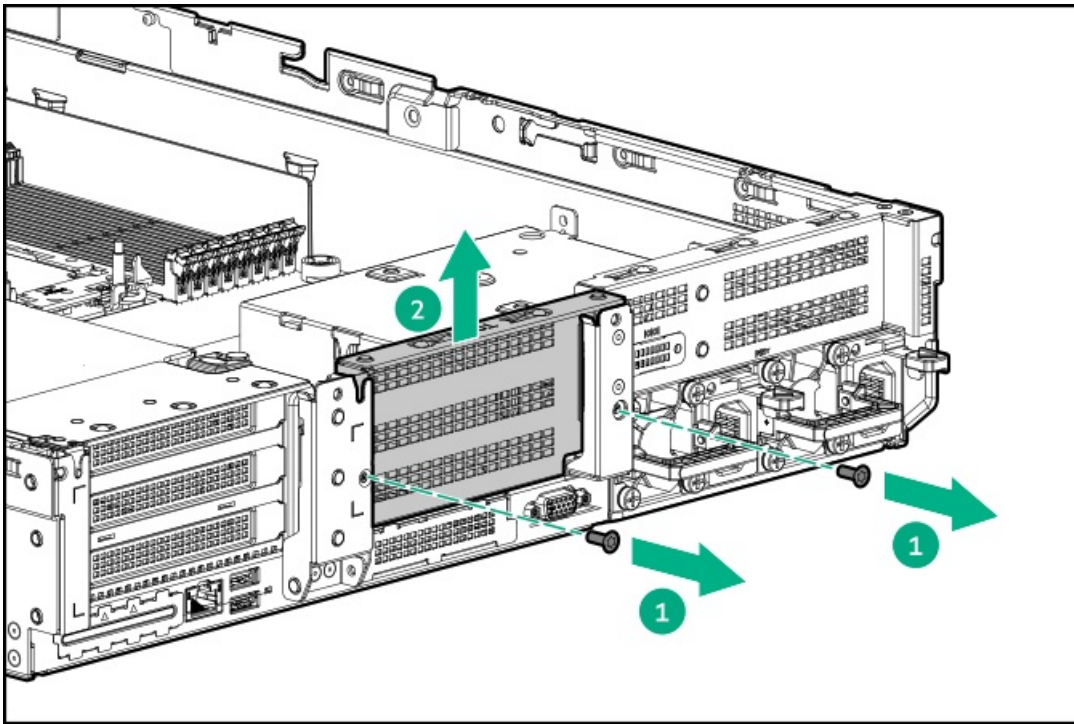

6. Install the drive cage.

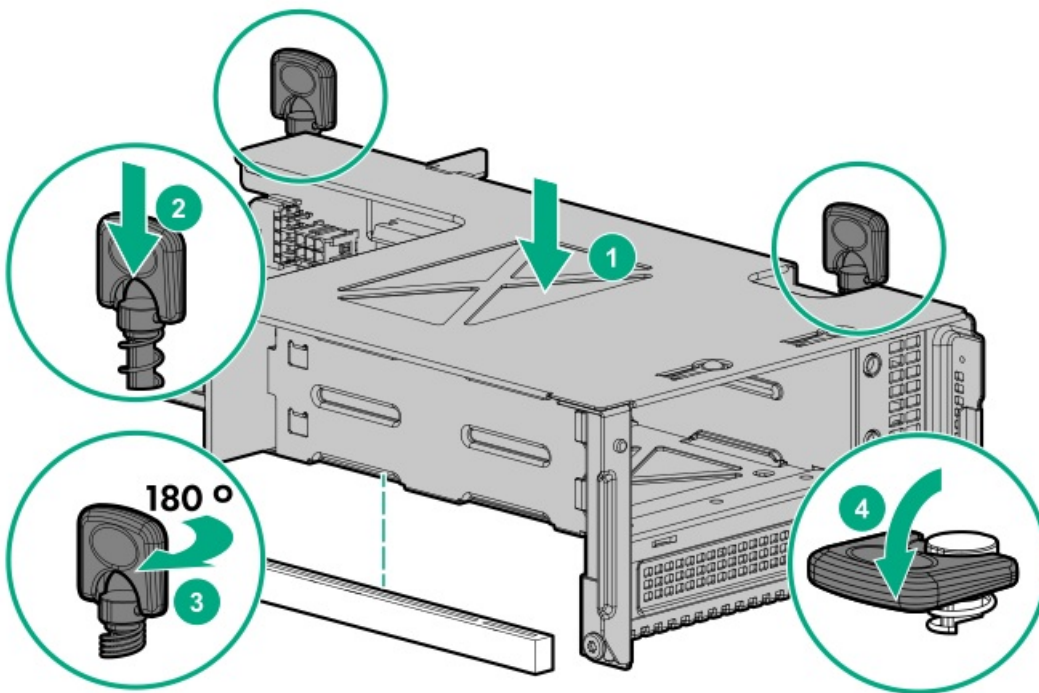

7. Cable the drive backplane.

8. Install drives or drive blanks.

9. Install the access panel.

10. Slide the server into the rack.

11. Connect each power cord to the server.

12. Connect each power cord to the power source.

13. Power up the server.

Installing a rear 2 SFF SAS/SATA drive cage over the power supplies

Prerequisites

Before you perform this procedure, make sure that you have the following items available:

- T-10 Torx screwdriver
- The components included with the hardware option kit
- The front bays are fully populated with 12 LFF or 24 SFF drives
- High-performance fans are installed in all fan bays

Procedure

1. Power down the server.
2. Remove all power:
 - a. Disconnect each power cord from the power source.
 - b. Disconnect each power cord from the server.
3. Do one of the following:
 - Extend the server from the rack.
 - Remove the server from the rack.
4. Remove the access panel.
5. Do one of the following:
 - If installed, remove the secondary riser cage.

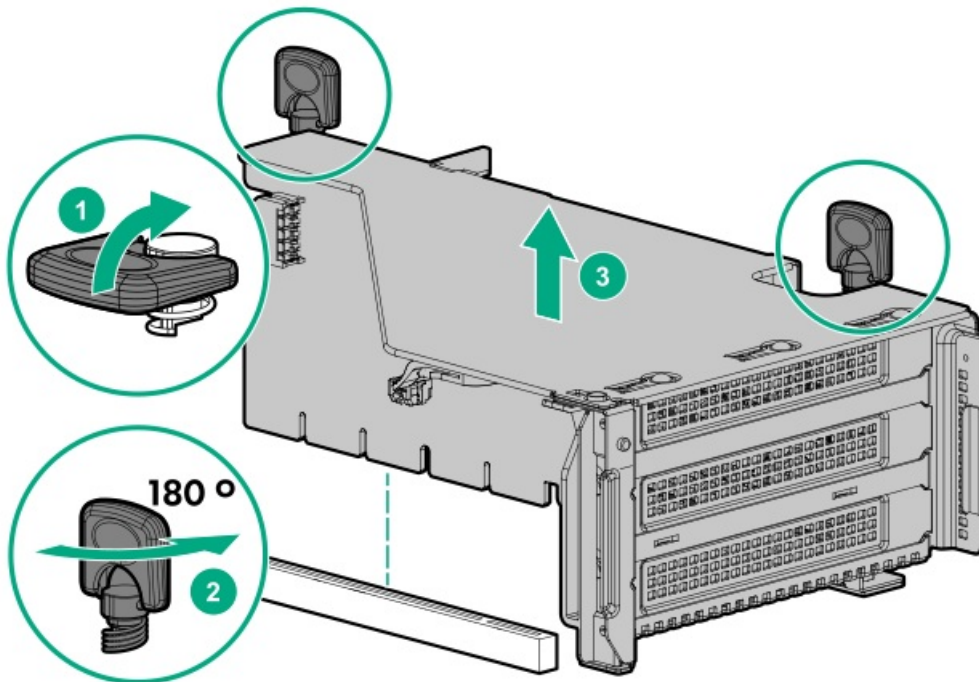

- Remove the secondary wall blank.

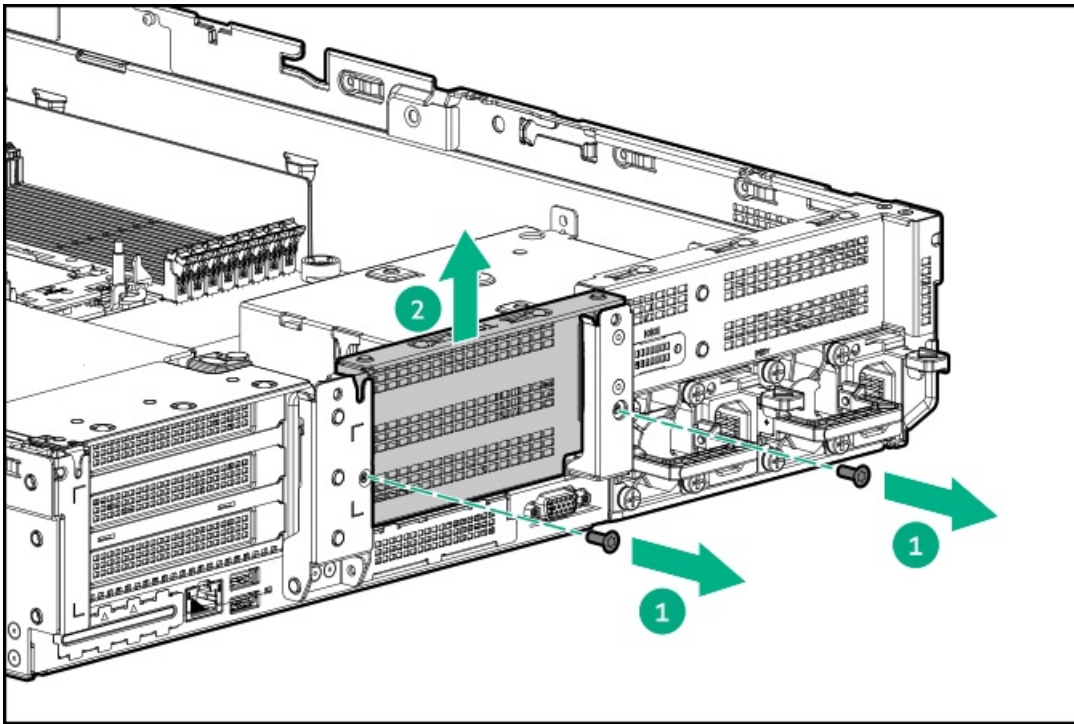

6. Remove the tertiary wall blank.

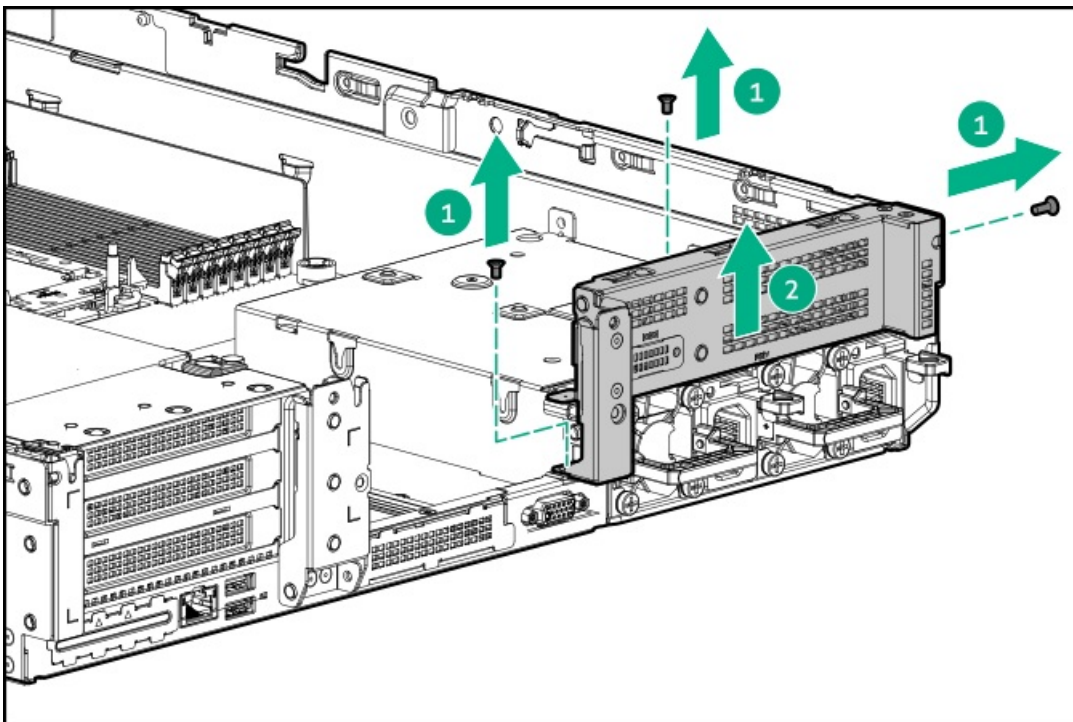

7. Install the drive cage compatible rear wall.

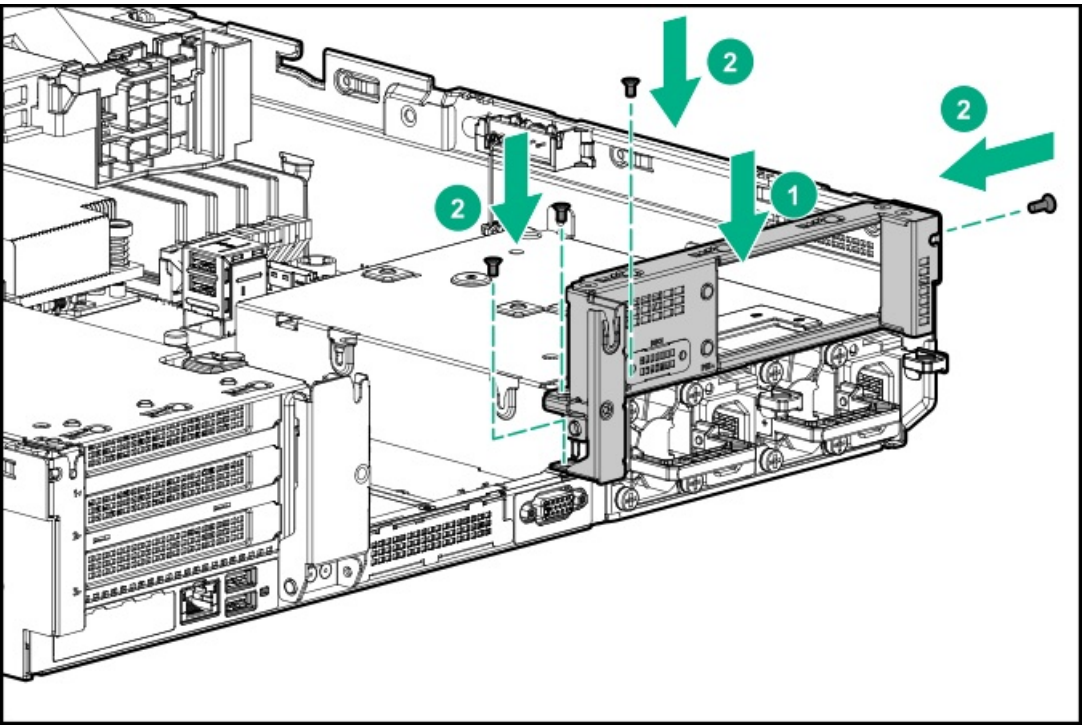

8. Install 4 rubber feet on the drive cage.

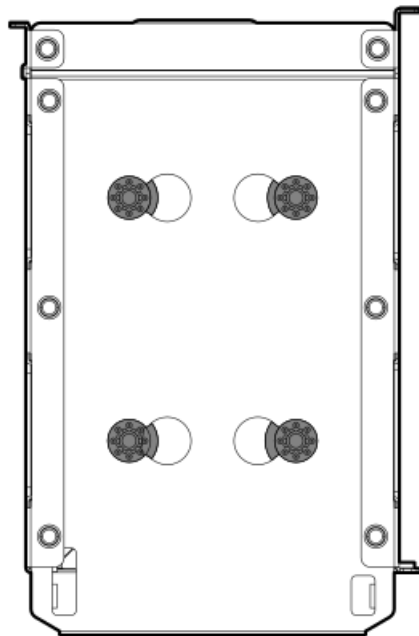

9. Install the drive cage.

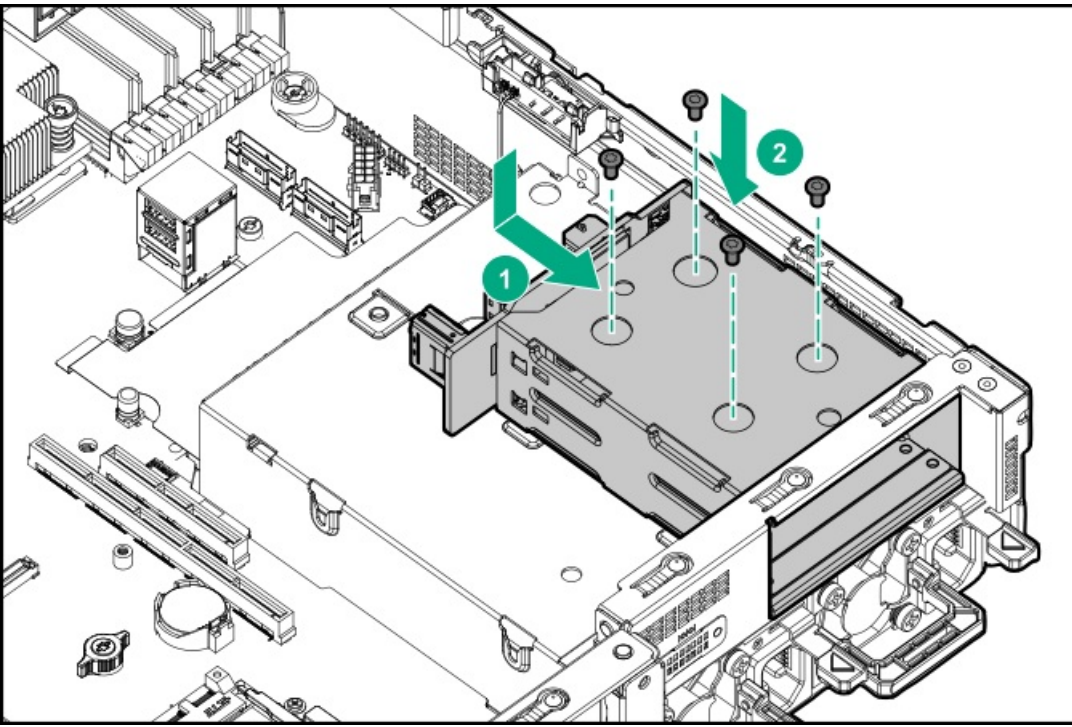

10. Install drives or drive blanks.
11. Install the secondary rear wall or a secondary riser cage.
12. Cable the drive backplane.
13. Install the access panel.
14. Slide the server into the rack.
15. Connect each power cord to the server.
16. Connect each power cord to the power source.
17. Power up the server.

Installing a rear 2LFF SAS/SATA drive cage in the primary or secondary riser

Prerequisites

Before you perform this procedure, make sure that you have the following items available:

- T-10 Torx screwdriver
- The components included with the hardware option kit
- The front drive bays are fully populated with 12 LFF or 24 SFF drives.
- High performance fans are installed in all fan bays.

Procedure

1. Power down the server.
2. Remove all power:
 - a. Disconnect each power cord from the power source.
 - b. Disconnect each power cord from the server.
3. Do one of the following:
 - Extend the server from the rack.
 - Remove the server from the rack.
4. Remove the access panel.
5. Do one of the following:
 - For primary bays, remove the riser cage.

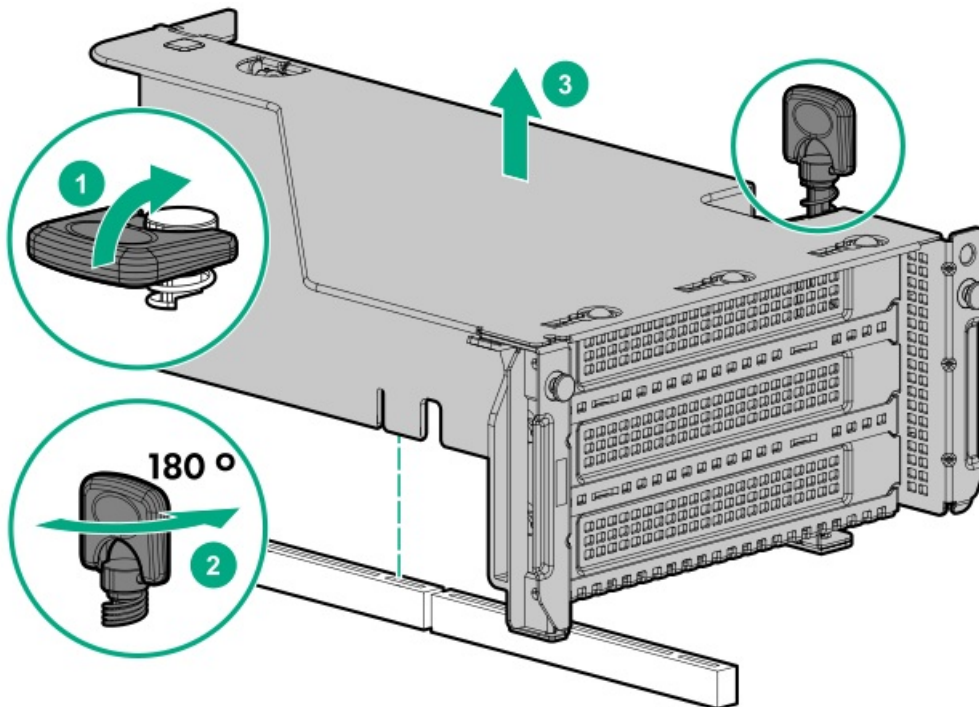

- For secondary bays, remove the rear wall blank.

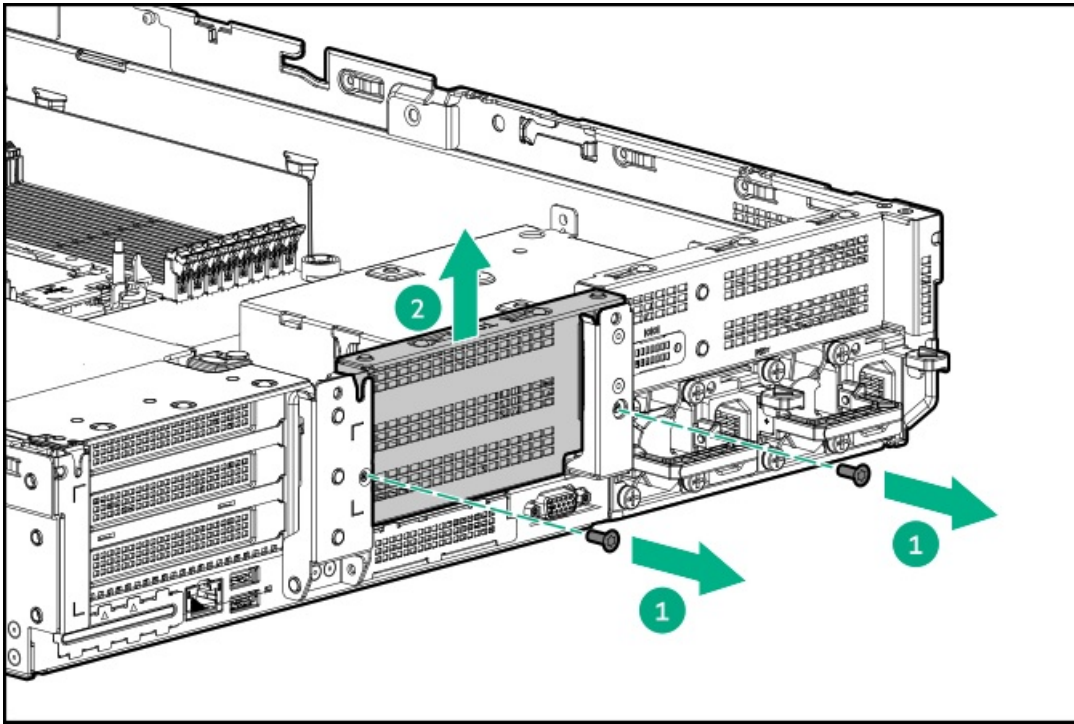

6. Install the drive cage.

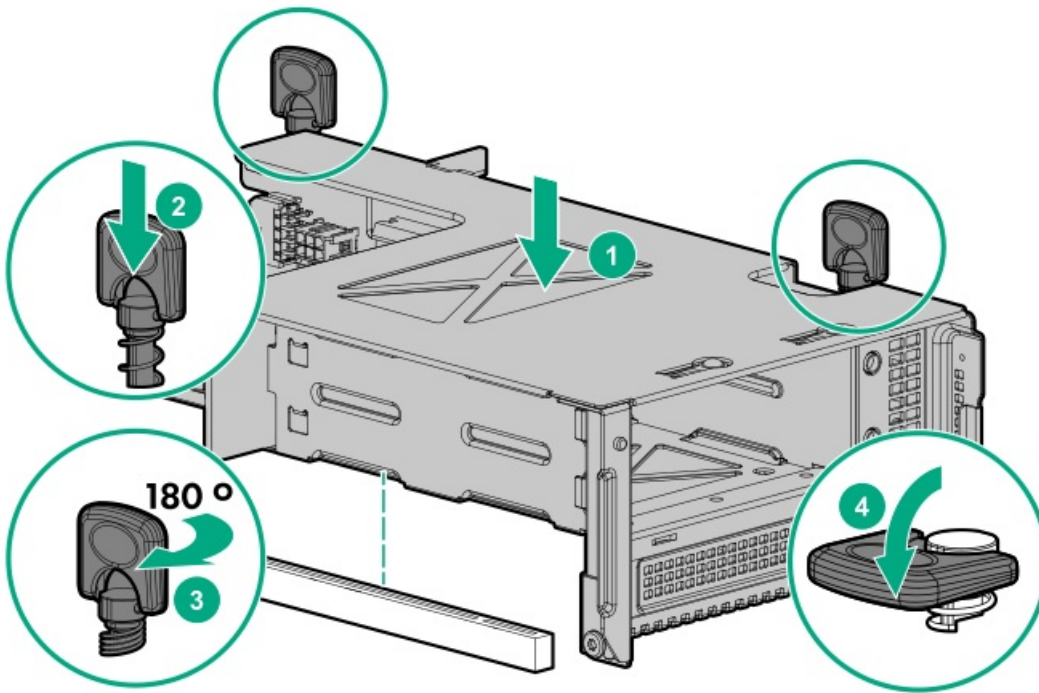

7. Cable the drive backplane.

8. Install drives or drive blanks.

9. Install the access panel.

10. Slide the server into the rack.

11. Connect each power cord to the server.

12. Connect each power cord to the power source.

13. Power up the server.

The installation is complete.

Installing a processor heatsink assembly

Prerequisites

Before installing this option, be sure that you have the following:

- The components included with the option kit
- T-30 Torx screwdriver

Procedure

1. Review the [heatsink and socket components](#).
2. Observe the following alerts.

△ CAUTION: When handling the heatsink, always hold it along the top and bottom of the fins. Holding it from the sides can damage the fins.

△ CAUTION: To prevent possible server malfunction and damage to the equipment, multiprocessor configurations must contain processors with the same part number.

△ CAUTION: If installing a processor with a faster speed, update the system ROM before installing the processor. To download firmware and view installation instructions, see the [Hewlett Packard Enterprise Support Center website](#).

△ CAUTION: THE CONTACTS ARE VERY FRAGILE AND EASILY DAMAGED. To avoid damage to the socket or processor, do not touch the contacts.

3. [Power down the server](#).
4. Remove all power:
 - a. Disconnect each power cord from the power source.
 - b. Disconnect each power cord from the server.
5. Do one of the following:
 - a. [Extending the server from the rack](#).
 - b. [Removing the server from the rack](#).
6. [Remove the access panel](#).
7. If installing processors over 205W, [install high performance fans](#).
8. Install the processor heatsink assembly:
 - a. Remove the dust cover from the socket.
 - b. Identify the front of server label on the heatsink.
 - c. Align the assembly with the socket and gently lower it down until it sits on the socket.

Be sure the latches lock the heatsink into place. The heatsink and socket are keyed. The processor will only install one way.

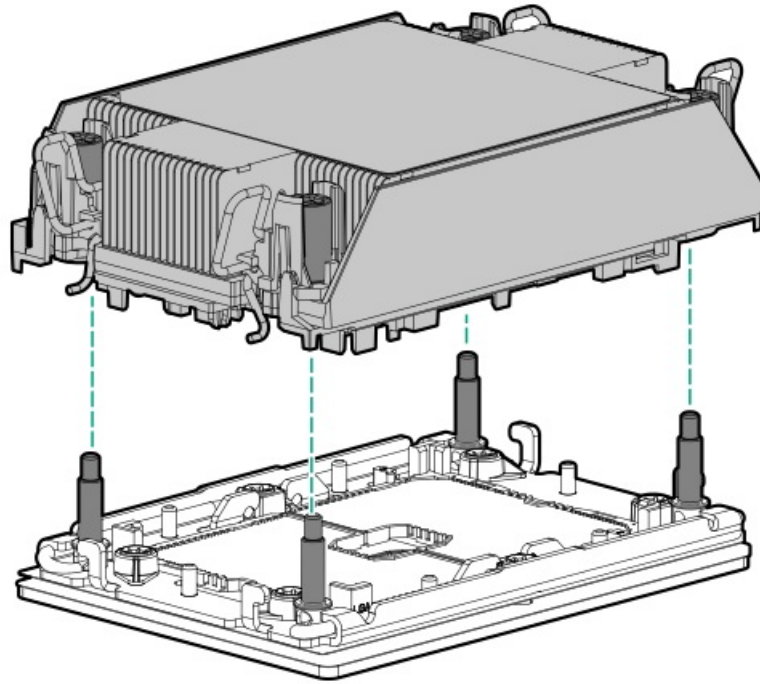

d. Using a T-30 Torx screwdriver, tighten the nuts.

 **NOTE:** Do not tighten the nuts more than 12 in-lbs or 1.3Nm. Overtightening could crack or damage the nuts.

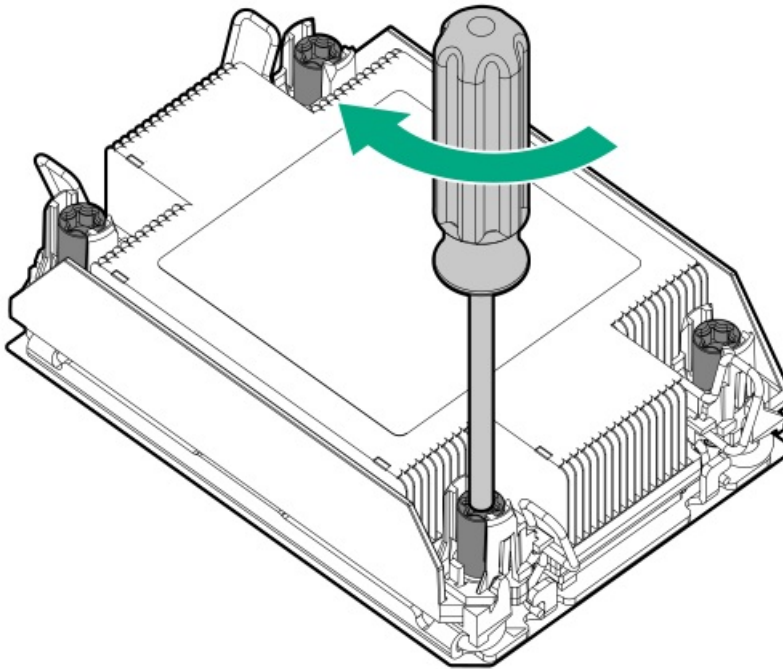

The installation is complete.



Installing a high performance heatsink

Prerequisites

-
- ⚠ **CAUTION:** Installing a high performance heatsink requires the installation of a processor assembly onto the heatsink. To avoid damage to server or components, do not remove or install the processor assembly when installing or replacing other heatsinks.
-

To determine when a high performance heatsink should be installed in the server, see the server QuickSpecs on the Hewlett Packard Enterprise (<https://www.hpe.com/info/qs>).

Before installing this option, be sure that you have the following:

- The components included with the hardware option kit
- T-30 Torx screwdriver

Procedure

1. Observe the following alerts.

⚠ **CAUTION:** The processor assembly must be removed and replaced as a unit. Do not remove the processor from the carrier.

⚠ **CAUTION:** When handling the heatsink, always hold it along the top and bottom of the fins. Holding it from the sides can damage the fins.

⚠ **CAUTION: THE CONTACTS ARE VERY FRAGILE AND EASILY DAMAGED.** To avoid damage to the socket or processor, do not touch the contacts.

2. Power down the server.

3. Remove all power:

- a. Disconnect each power cord from the power source.
- b. Disconnect each power cord from the server.

4. Do one of the following:

- a. Extending the server from the rack.
- b. Removing the server from the rack.

5. Remove the access panel.

6. Observe the following cautions.

⚠ **CAUTION:** Be sure to loosen each heatsink nut in the order indicated. Otherwise, damage might occur to the heatsink or processor.

⚠ **CAUTION:** Install the processor heatsink assembly as soon as possible after removing it. Do not leave the processor socket unpopulated for extended periods of time.

7. Remove the existing processor heatsink assembly:

- a. Allow the heatsink to cool.
- b. Using a T-30 Torx screwdriver, loosen the heatsink nuts.

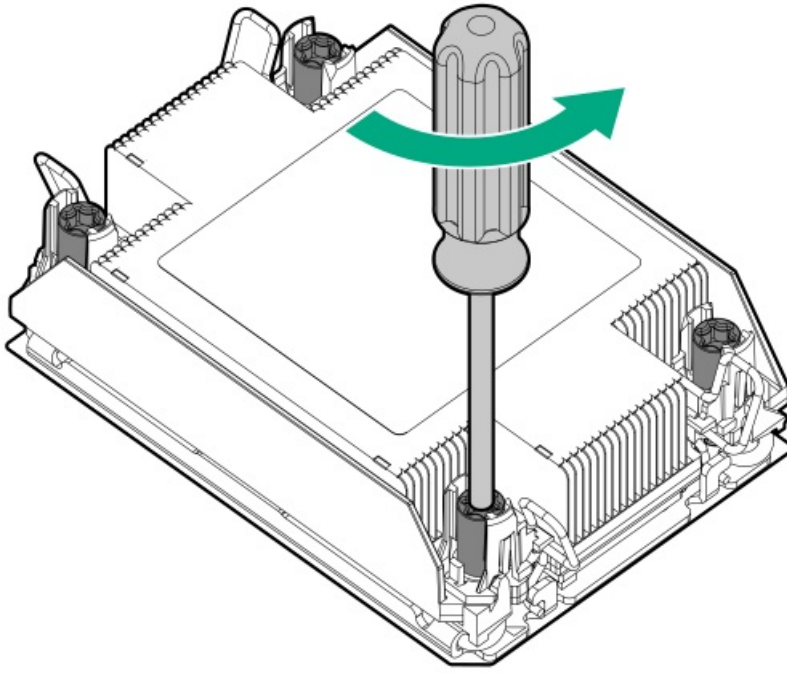

c. Remove the processor heatsink assembly.

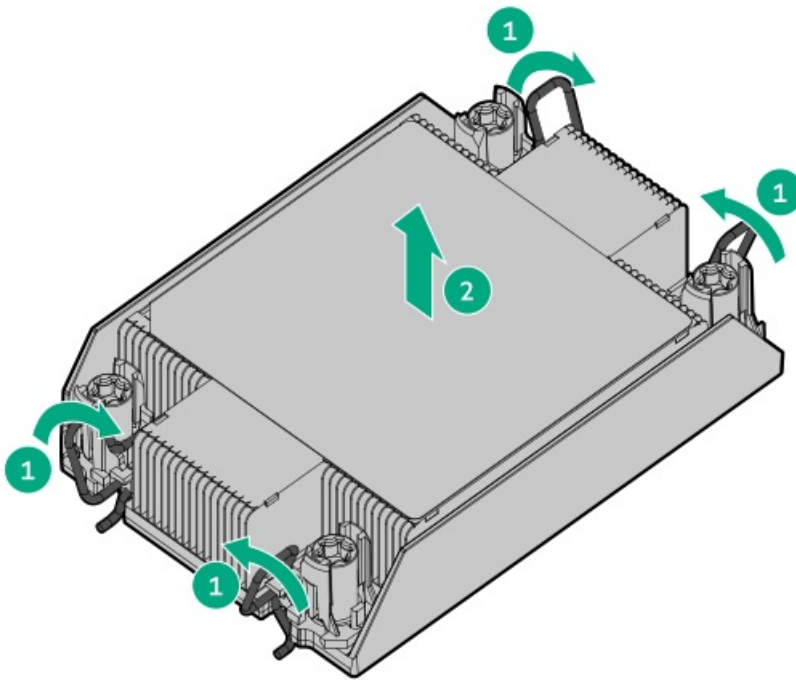

d. Turn the processor heatsink assembly over and place it on a work surface with the processor assembly facing up.

8. Release the processor from the heatsink:

Be sure to unlatch all corners of the processor carrier.

The processor remains attached to the carrier.



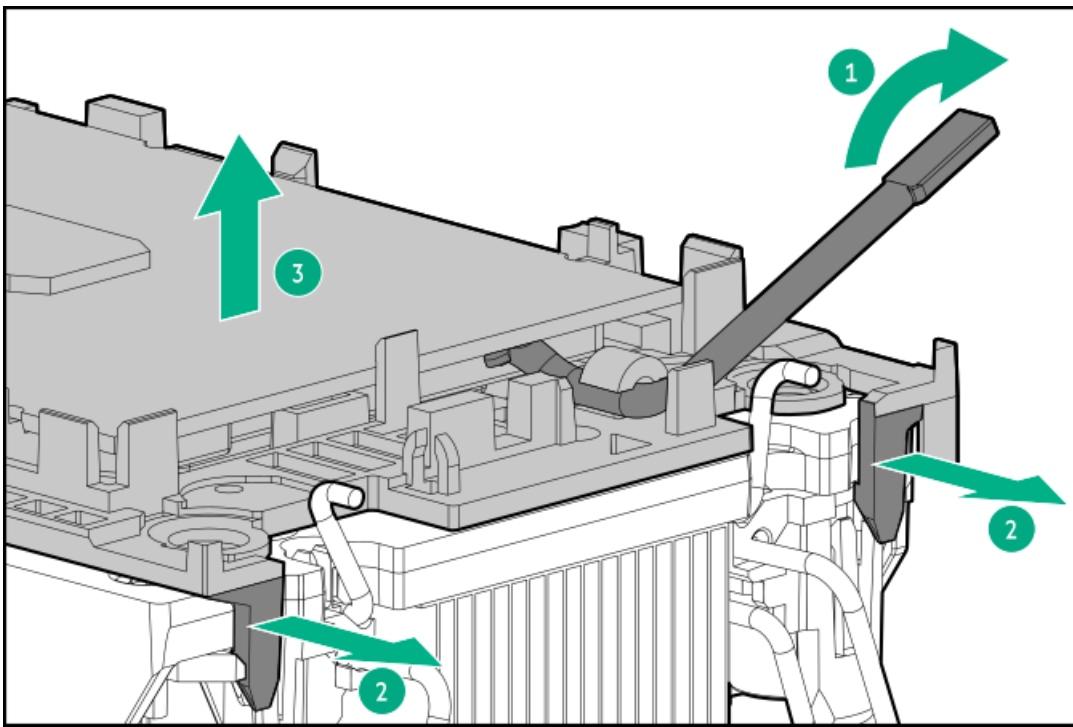

9. Using an alcohol wipe, remove the existing thermal grease from the processor and heatsink. Allow the alcohol to evaporate before continuing.
10. Remove the plastic cover protecting the thermal grease on the high performance heatsink.
11. Align the Pin 1 indicators on the processor and the heatsink, and then install the processor assembly to the heatsink.

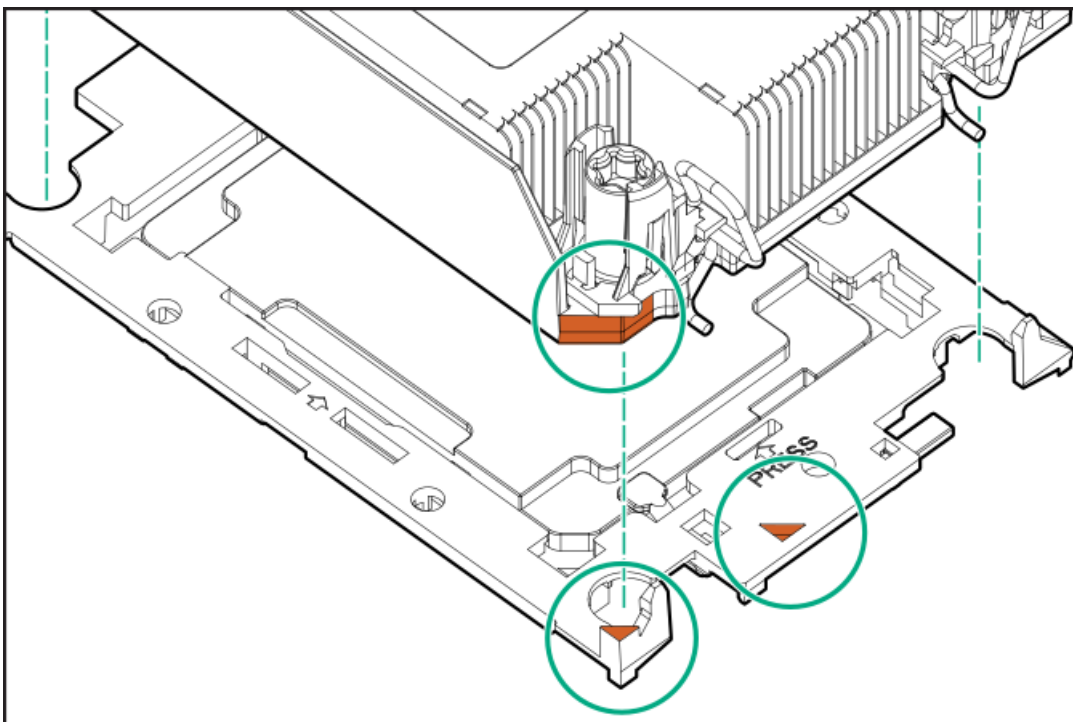

12. Install the processor heatsink assembly:
 - a. Identify the front of server label on the heatsink.
 - b. Align the assembly with the alignment posts and gently lower it down until it sits on the socket.

The processor heatsink assembly will only install one way.

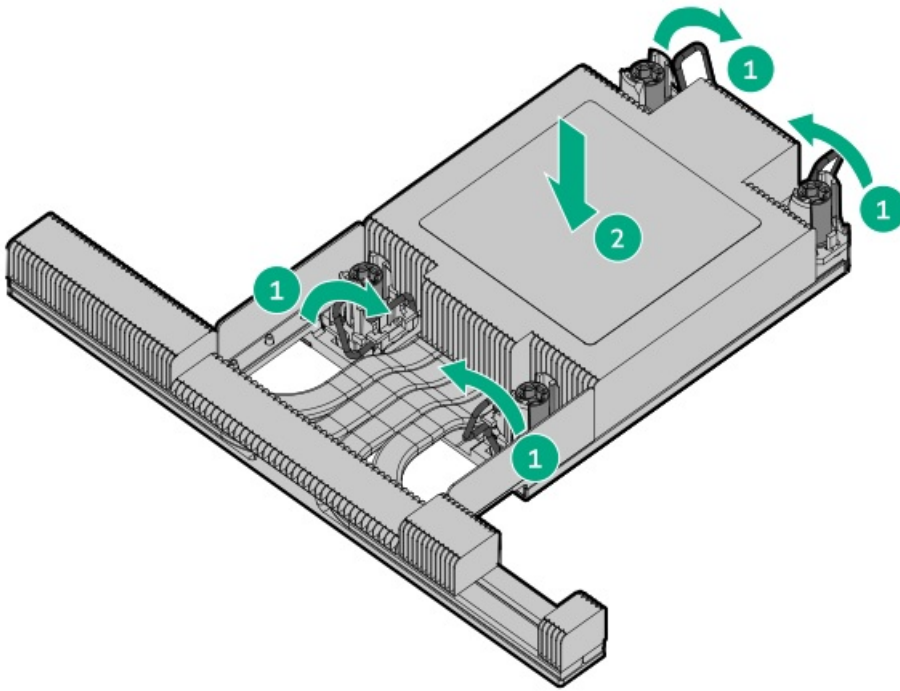

c. Using a T-30 Torx screwdriver, tighten the nuts.

 **NOTE:** Do not tighten the nuts more than 12 in-lbs or 1.3Nm. Overtightening could crack or damage the nuts.

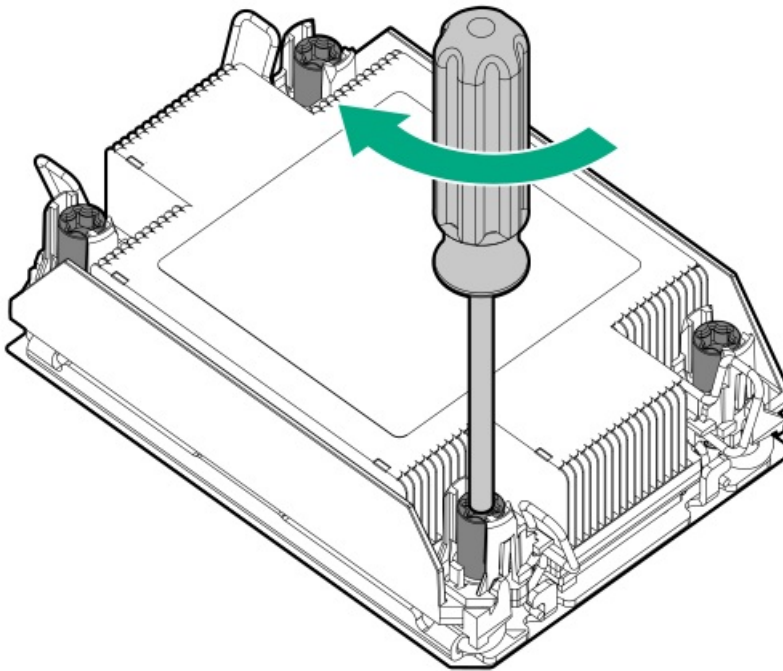

The installation is complete.

Installing the chassis intrusion detection switch

Prerequisites

Before you perform this procedure, make sure that you have the components included with the hardware option kit.

Procedure

1. Power down the server.
2. Remove all power:
 - a. Disconnect each power cord from the power source.
 - b. Disconnect each power cord from the server.
3. Do one of the following:
 - Extend the server from the rack.
 - Remove the server from the rack.
4. Remove the access panel.
5. Install the chassis intrusion detection switch.

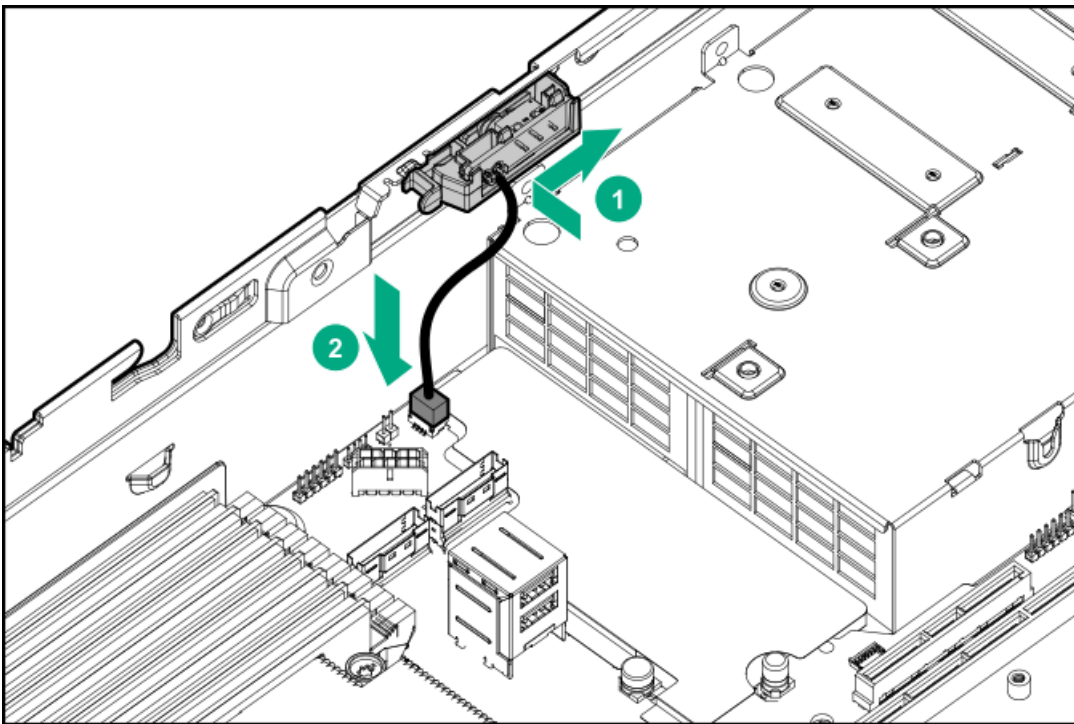

6. Install the access panel.
7. Install the server into the rack.
8. Connect each power cord to the server.
9. Connect each power cord to the power source.
10. Power up the server.

Installing an OCP 3.0 adapter card

Prerequisites

Before you begin this procedure, make sure that the components included with the hardware option kit are available.

Procedure

1. Power down the server.
2. Remove all power:
 - a. Disconnect each power cord from the power source.
 - b. Disconnect each power cord from the server.
3. Do one of the following:
 - Extend the server from the rack.
 - Remove the server from the rack.
4. Remove the access panel.
5. Remove the rear wall blank or riser.
6. Remove the OCP 3.0 adapter blank.

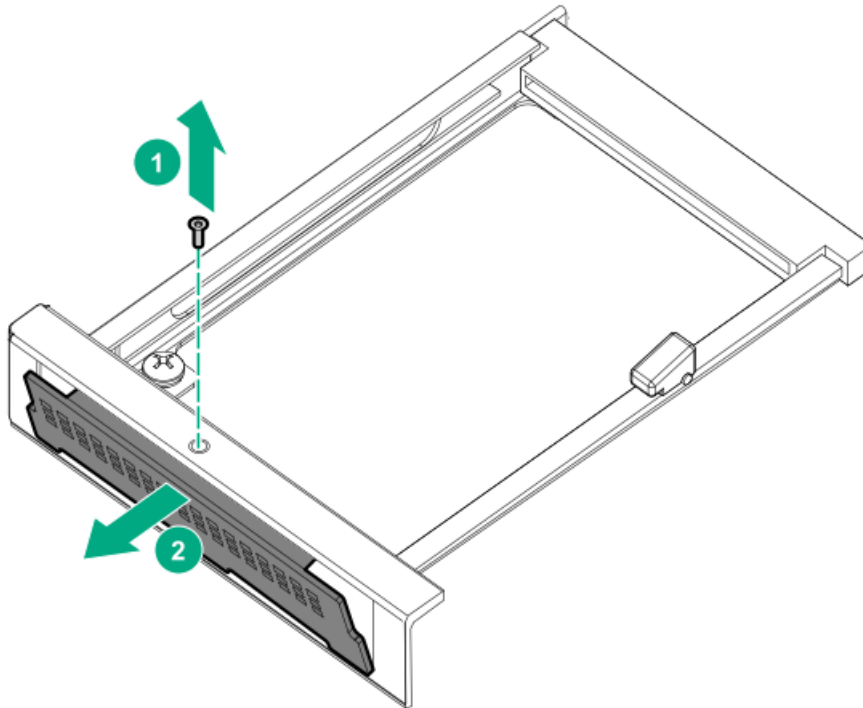

7. Install the OCP 3.0 adapter.

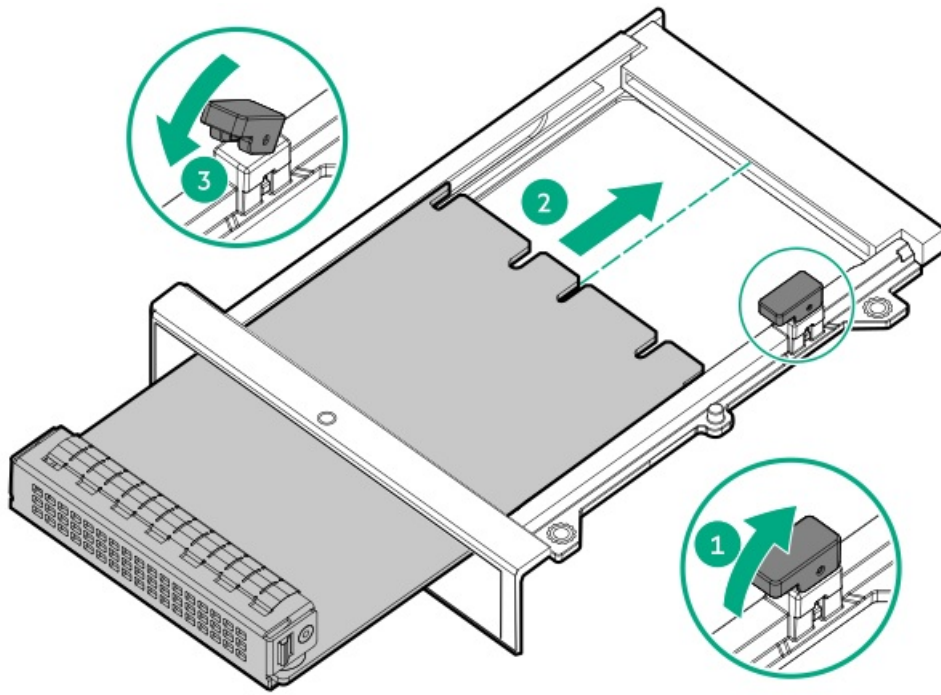

8. Connect the cables.
9. Install the access panel.
10. Slide the server into the rack.
11. Connect each power cord to the server.
12. Connect each power cord to the power source.
13. Power up the server.

Installing the Pensando DSP DSC-25 2p SFP28 card

Procedure

1. Power down the server.
2. Do one of the following:
 - Extend the front drive cages out of the chassis.
 - Remove the server from the rack.
 - Remove the compute module from the enclosure.
3. Place the server on a flat, level work surface.
4. Remove the access panel.
5. Remove the PCIe riser cage, if applicable.

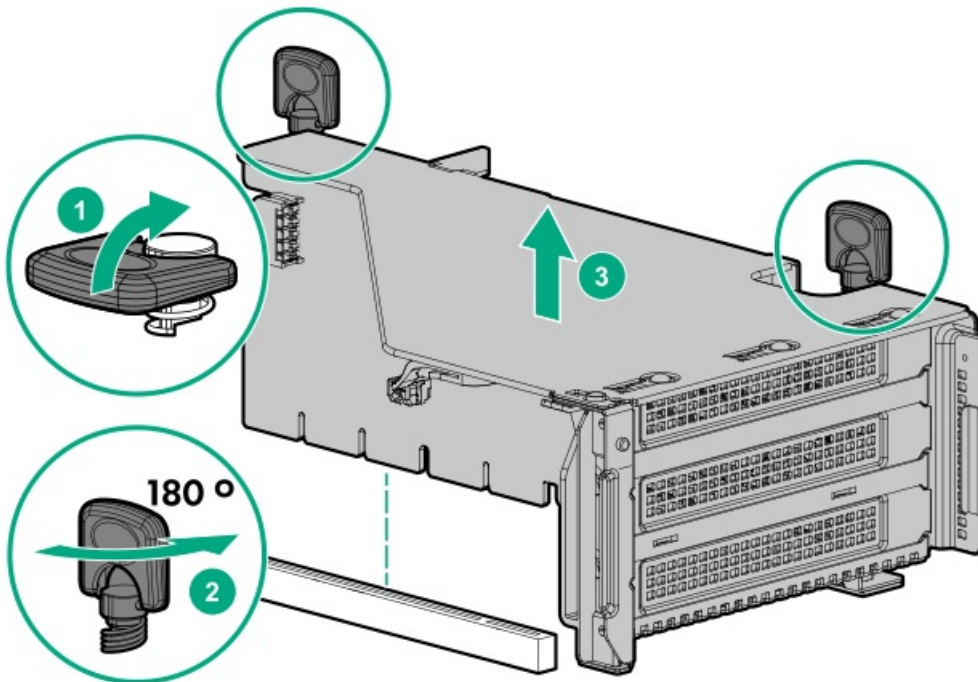

6. Install the Pensando DSP DSC-25 2p SFP28 card into the PCIe slot.

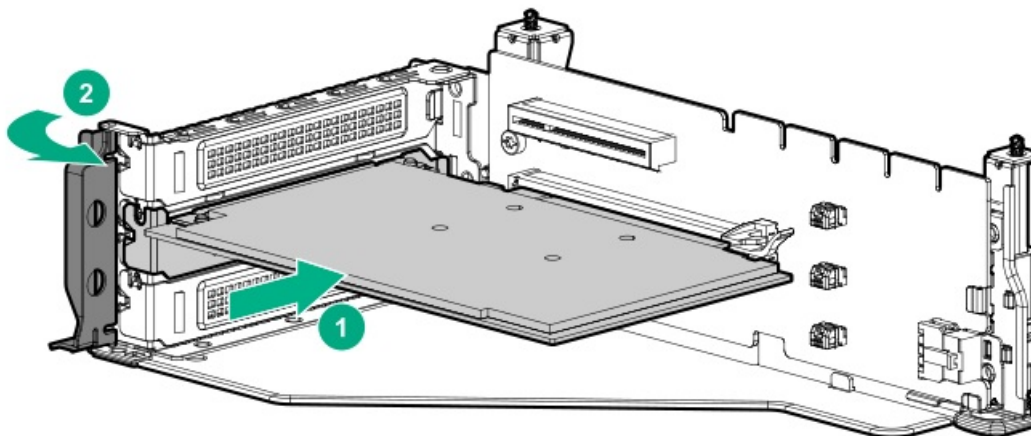

7. Install the PCIe riser cage into the server.

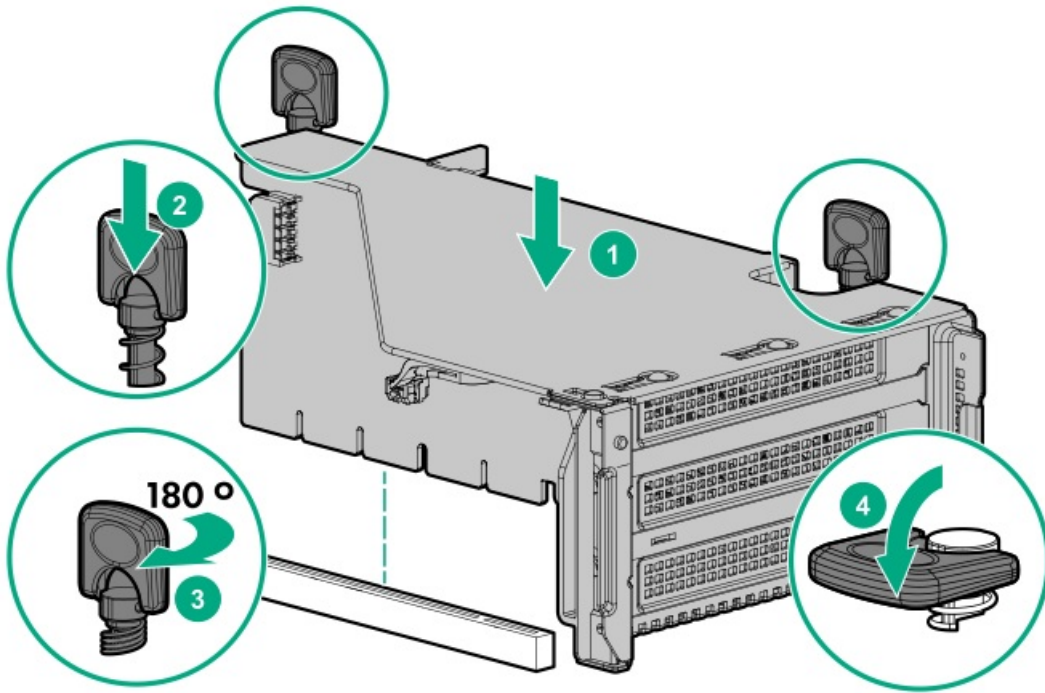

8. Install the access panel.
9. Slide the server into the rack.
10. Connect each power cord to the server.
11. Connect each power cord to the power source.
12. Power up the server.
13. Admit the new card to the Pensando Policy and Services Manager (PSM).

For more information, see the PSM Enterprise Edition User Guide.

Installing the HPE NS204i-p NVMe OS Boot Device option

Prerequisites

Before beginning installation, ensure that the server is updated with the latest operating system firmware and drivers.

Procedure

Installing drives onto the boot device

1. Remove the liner from the thermal interface pad.

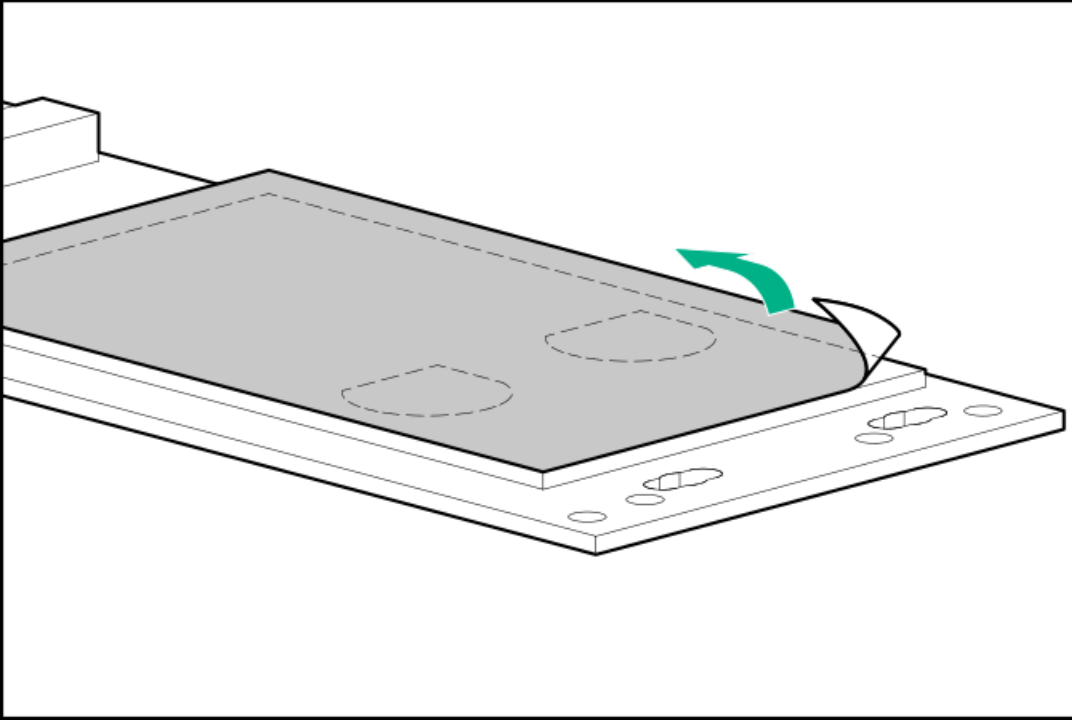

2. Install the drives.

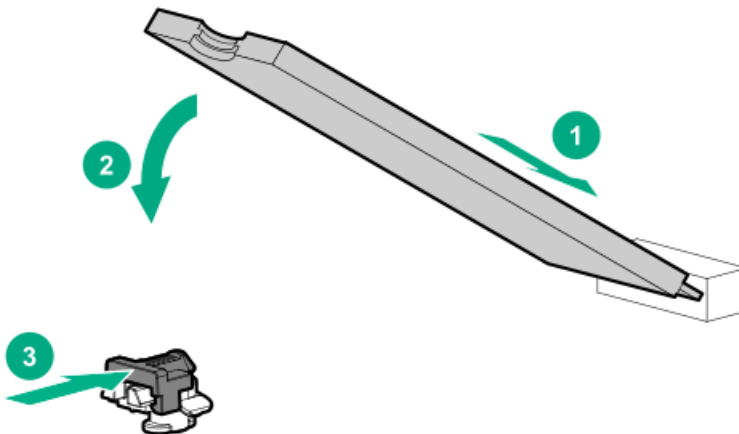

Installing the boot device

3. Power down the system.
4. Do one of the following:
 - Extend the front drive cages out of the chassis.
 - Remove the system from the rack.
 - Remove the compute module from the enclosure.
5. Place the server on a flat, level work surface.

6. Remove the access panel.
7. Select an available PCIe expansion slot that is x8 physical size and x4 electrical.
8. Remove the expansion slot cover.
Save the retaining screw, if one is present.
9. Install the boot device.

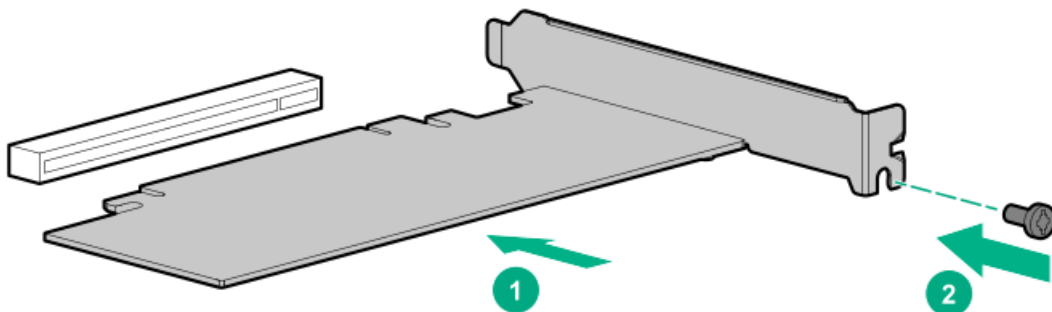

10. Install any components that were removed to access the expansion slot.
11. Install the access panel.
12. Do one of the following:
 - Slide the server into the rack.
 - Install the server into the rack.
13. Power up the server.

Deploying an operating system

14. Deploy a supported operating system to the boot device drive.

For more information, see the product QuickSpecs (<https://www.hpe.com/info/qs>).

After the OS installation completes, the system automatically copies the operating system to the second, mirrored drive on the boot device.

15. Proceed with normal system setup and operation.

Installing a rear serial port interface

Prerequisites

Before you perform this procedure, make sure that you have the following items available:

The components included with the hardware option kit

Procedure

1. Power down the server.
2. Do one of the following:
 - Disconnect each power cord from the power source.
 - Disconnect each power cord from the server.
3. Do one of the following:
 - Extend the server from the rack.
 - Remove the server from the rack.
4. Remove the access panel.
5. Remove the serial port blank.

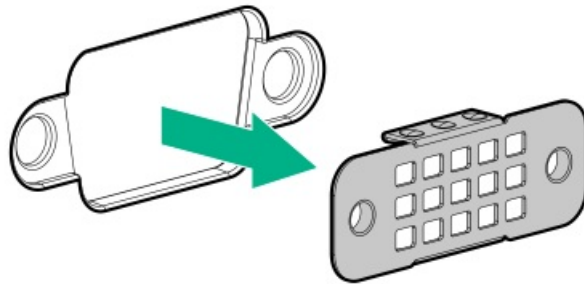

6. Install the serial port interface.

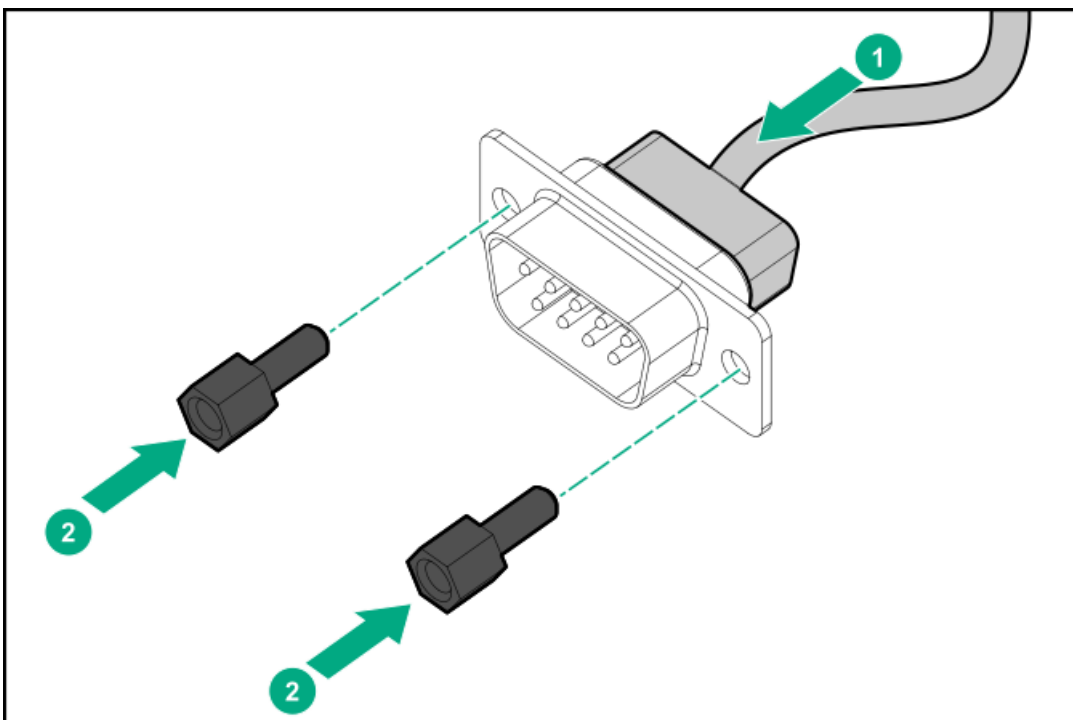

7. Connect the cable to the system board.



8. Install the access panel.
9. Install the server in the rack.
10. Connect each power cord to the server.
11. Connect each power cord to the power source.
12. Power up the server.

The installation is complete.



Installing the Systems Insight Display

Prerequisites

Before you perform this procedure, make sure that you have the following items available:

- The components included with the hardware option kit
- T-10 Torx screwdriver

Procedure

1. Power down the server.
2. Remove all power:
 - a. Disconnect each power cord from the power source.
 - b. Disconnect each power cord from the server.
3. Do one of the following:
 - Extend the server from the rack.
 - Remove the server from the rack.
4. Remove the access panel.
5. Do one of the following:
 - Remove the air baffle.
 - If installed, remove the 4LFF midplane drive cage.
6. Remove the fan cage.
7. Disconnect the power switch module cable from the power switch/SID module connector.
The SID module cable connects to the same connector.
8. Remove the power switch module. Retain the T-10 screw.

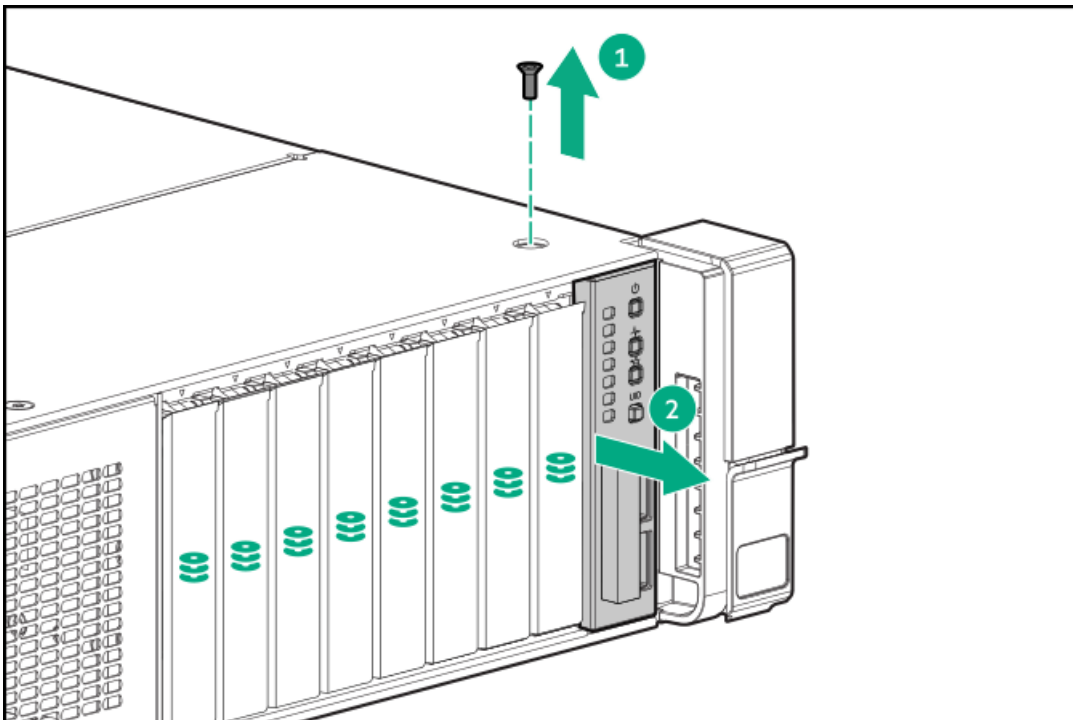

CAUTION: When routing cables, make sure that the cables are not in a position where they can be pinched or crimped.

9. Route the SID cable through the opening in the front of the server, and then install the SID module. Secure the module using the T-

10 screw.

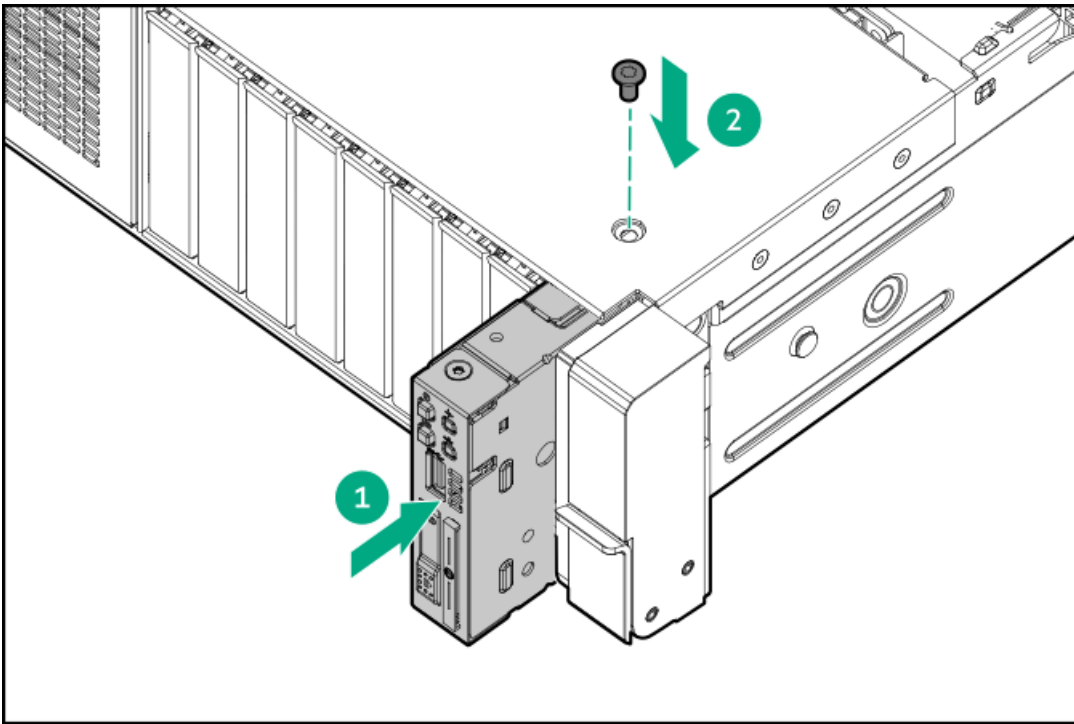

10. Connect the SID module cable to the power switch/SID module connector.

11. Install the fan cage.

12. Do one of the following:

- Install the air baffle.
- Installing the midplane or air baffle .

13. Install the access panel.

14. Slide the server into the rack.

15. Connect each power cord to the server.

16. Connect each power cord to the power source.

17. Power up the server.

The installation is complete.





Overview

Use these instructions to install and enable an HPE TPM 2.0 Gen10 Plus Kit in a supported server. This option is not supported on Gen10 and earlier servers.

This procedure includes three sections:

1. Installing the Trusted Platform Module board.
2. Enabling the Trusted Platform Module.
3. Retaining the recovery key/password.

HPE TPM 2.0 installation is supported with specific operating system support such as Microsoft Windows Server 2012 R2 and later. For more information about operating system support, see the product QuickSpecs on the Hewlett Packard Enterprise website (<https://www.hpe.com/info/qs>). For more information about Microsoft Windows BitLocker Drive Encryption feature, see the Microsoft website (<https://www.microsoft.com>).

 **CAUTION:** If the TPM is removed from the original server and powered up on a different server, data stored in the TPM including keys will be erased.

 **IMPORTANT:** In UEFI Boot Mode, the can be configured to operate as TPM 2.0 (default) or TPM 1.2 on a supported server. In Legacy Boot Mode, the configuration can be changed between TPM 1.2 and TPM 2.0, but only TPM 1.2 operation is supported.

HPE Trusted Platform Module 2.0 guidelines

 **CAUTION:** Always observe the guidelines in this document. Failure to follow these guidelines can cause hardware damage or halt data access.

Hewlett Packard Enterprise SPECIAL REMINDER: Before enabling TPM functionality on this system, you must ensure that your intended use of TPM complies with relevant local laws, regulations and policies, and approvals or licenses must be obtained if applicable.

For any compliance issues arising from your operation/usage of TPM which violates the above mentioned requirement, you shall bear all the liabilities wholly and solely. Hewlett Packard Enterprise will not be responsible for any related liabilities.

慧与特别提醒：在您启用系统中的TPM功能前，请务必确认您对TPM的使用遵守当地相关法律、法规及政策，并已事先获得所需的一切批准及许可（如适用），因您未获得相应的操作/使用许可而导致的违规问题，皆由您自行承担全部责任，与慧与无涉。

When installing or replacing a TPM, observe the following guidelines:

- Do not remove an installed TPM. Once installed, the TPM becomes a permanent part of the system board.
- When installing or replacing hardware, Hewlett Packard Enterprise service providers cannot enable the TPM or the encryption technology. For security reasons, only the customer can enable these features.
- When returning a system board for service replacement, do not remove the TPM from the system board. When requested, Hewlett Packard Enterprise Service provides a TPM with the spare system board.
- Any attempt to remove the cover of an installed TPM from the system board can damage the TPM cover, the TPM, and the system board.
- If the TPM is removed from the original server and powered up on a different server, all data stored in the TPM including keys will be erased.
- When using BitLocker, always retain the recovery key/password. The recovery key/password is required to complete Recovery Mode after BitLocker detects a possible compromise of system integrity.
- Hewlett Packard Enterprise is not liable for blocked data access caused by improper TPM use. For operating instructions, see the TPM documentation or the encryption technology feature documentation provided by the operating system.

Installing and enabling the HPE TPM 2.0 Gen10 Plus option

Installing the Trusted Platform Module board



Preparing the server for installation

Procedure

1. Observe the following warnings:

WARNING: The front panel Power On/Standby button does not shut off system power. Portions of the power supply and some internal circuitry remain active until AC power is removed.

To reduce the risk of personal injury, electric shock, or damage to the equipment, remove power from the server:

- For rack and tower servers, remove the power cord.
 - For server blades and compute modules, remove the server blade or compute module from the enclosure.
-
-

WARNING: To reduce the risk of personal injury from hot surfaces, allow the drives and the internal system components to cool before touching them.

2. Update the system ROM.

Locate and download the latest ROM version from the Hewlett Packard Enterprise Support Center website (<https://www.hpe.com/support/hpesc>). To update the system ROM, follow the instructions on the website.

3. Power down the server.
 - a. Shut down the OS as directed by the OS documentation.
 - b. To place the server in standby mode, press the Power On/Standby button. When the server enters standby power mode, the system power LED changes to amber.
 - c. Disconnect the power cords (rack and tower servers).
4. Do one of the following:
 - Depending on your product, extend or remove the server from the rack.
 - Remove the server from the enclosure.
5. If removed, place the server on a flat, level work surface.
6. Remove the access panel.
7. Remove any options or cables that might prevent access to the TPM connector.
8. Proceed to "Installing the TPM board and cover."

Installing the TPM board and cover

Procedure

1. Observe the following alerts:

CAUTION: If the TPM is removed from the original server and powered up on a different server, data stored in the TPM including keys will be erased.

CAUTION: The TPM is keyed to install only in the orientation shown. Any attempt to install the TPM in a different orientation might result in damage to the TPM or system board.

2. Install the TPM board:

- a. Locate the TPM connector on the system board. See the server hood label for the exact location.
- b. Align the TPM board with the key on the connector, and then install the TPM board. To seat the board, press the TPM board firmly into the connector.

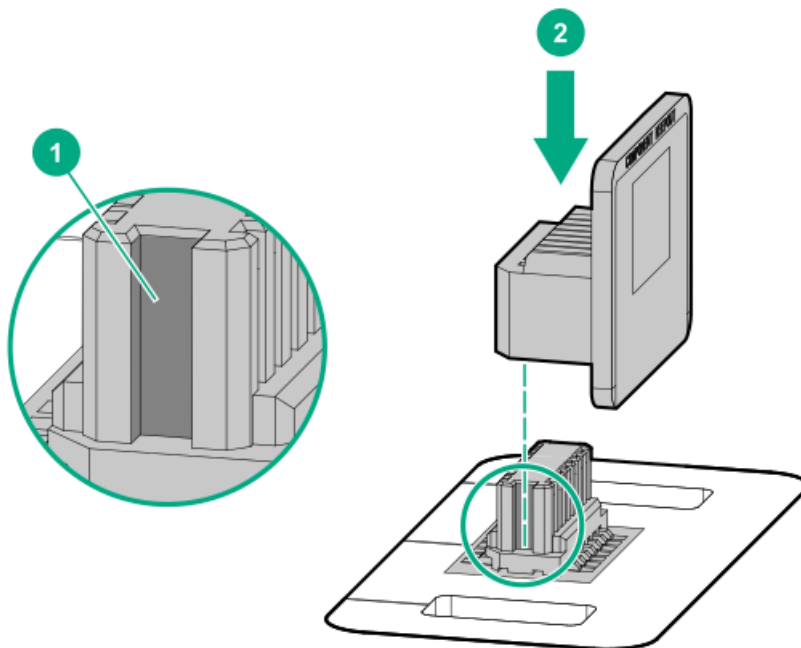

3. Install the TPM cover:

- a. Align the pins on the cover with the openings on the system board.
- b. Press straight down on the middle of the cover until the alignment pins are seated into the holes.

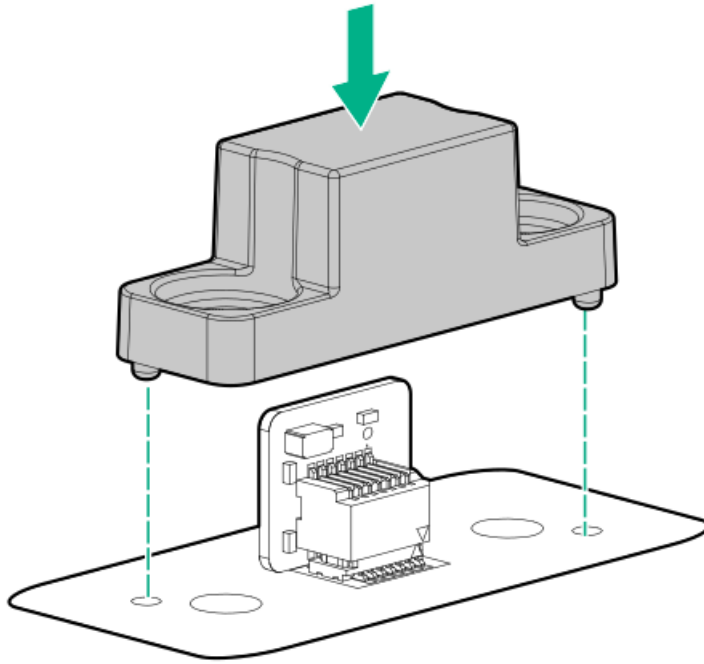

4. Secure the rivets into place by pushing them firmly through the holes in the TPM cover.

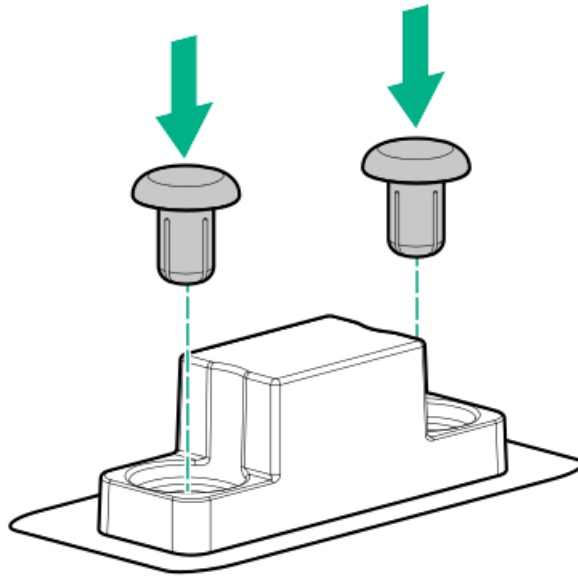

5. Proceed to "Preparing the server for operation."

Preparing the server for operation

Procedure

1. Install any options or cables previously removed to access the TPM connector.
2. Install the access panel.
3. Do one of the following:
 - Slide or install the server into the rack.
 - Install the server into the enclosure.
4. Power up the server.
 - a. Connect the power cords (rack and tower servers).
 - b. Press the Power On/Standby button.

Enabling the Trusted Platform Module

When enabling the Trusted Platform module, observe the following guidelines:

- By default, the Trusted Platform Module is enabled as TPM 2.0 when the server is powered on after installing it.
- In UEFI Boot Mode, the Trusted Platform Module can be configured to operate as TPM 2.0 (default) or TPM 1.2.
- In Legacy Boot Mode, the Trusted Platform Module configuration can be changed between TPM 1.2 and TPM 2.0 (default), but only TPM 1.2 operation is supported.

Enabling the Trusted Platform Module as TPM 2.0

Procedure

1. During the server startup sequence, press the F9 key to access System Utilities.
2. From the System Utilities screen, select System Configuration > BIOS/Platform Configuration (RBSU) > Server Security > Trusted Platform Module options.
3. Verify the following:
 - "Current TPM Type" is set to TPM 2.0.
 - "Current TPM State" is set to Present and Enabled.
 - "TPM Visibility" is set to Visible.
4. If changes were made in the previous step, press the F10 key to save your selection.
5. If F10 was pressed in the previous step, do one of the following:
 - If in graphical mode, click Yes.
 - If in text mode, press the Y key.
6. Press the ESC key to exit System Utilities.
7. If changes were made and saved, the server prompts for reboot request. Press the Enter key to confirm reboot.

If the following actions were performed, the server reboots a second time without user input. During this reboot, the TPM setting becomes effective.

- Changing from TPM 1.2 and TPM 2.0
 - Changing TPM bus from FIFO to CRB
 - Enabling or disabling TPM
 - Clearing the TPM
8. Enable TPM functionality in the OS, such as Microsoft Windows BitLocker or measured boot.

For more information, see the [Microsoft website](#).

Enabling the Trusted Platform Module as TPM 1.2

Procedure

1. During the server startup sequence, press the F9 key to access System Utilities.
2. From the System Utilities screen select System Configuration > BIOS/Platform Configuration (RBSU) > Server Security > Trusted Platform Module options.
3. Change the "TPM Mode Switch Operation" to TPM 1.2.
4. Verify that "TPM Visibility" is set to Visible.
5. Press the F10 key to save your selection.
6. When prompted to save the change in System Utilities, do one of the following:
 - If in graphical mode, click Yes.
 - If in text mode, press the Y key.
7. Press the ESC key to exit System Utilities.

The server reboots a second time without user input. During this reboot, the TPM setting becomes effective.

8. Enable TPM functionality in the OS, such as Microsoft Windows BitLocker or measured boot.

For more information, see the [Microsoft website](#).

Retaining the BitLocker recovery key/password

The recovery key/password is generated during BitLocker setup, and can be saved and printed after BitLocker is enabled. When using BitLocker, always retain the recovery key/password. The recovery key/password is required to enter Recovery Mode after BitLocker detects a possible compromise of system integrity.

To help ensure maximum security, observe the following guidelines when retaining the recovery key/password:

- Always store the recovery key/password in multiple locations.
- Always store copies of the recovery key/password away from the server.
- Do not save the recovery key/password on the encrypted hard drive.

Cabling guidelines

The cable colors in the cabling diagrams used in this chapter are for illustration purposes only.

Observe the following guidelines when working with server cables.

Before connecting cables

- Note the port labels on the PCA components. Not all these components are used by all servers:
 - System board ports
 - Drive and power supply backplane ports
 - Expansion board ports (controllers, adapters, expanders, risers, and similar boards)
- Note the label near each cable connector. This label indicates the destination port for the cable connector.
- Some data cables are prebent. Do not unbend or manipulate the cables.
- To prevent mechanical damage or depositing oil that is present on your hands, and other contamination, do not touch the ends of the connectors.

When connecting cables

- Before connecting a cable to a port, lay the cable in place to verify the length of the cable.
- Use the internal cable management features to properly route and secure the cables.
- When routing cables, be sure that the cables are not in a position where they can be pinched or crimped.
- Avoid tight bend radii to prevent damaging the internal wires of a power cord or a server cable. Never bend power cords and server cables tight enough to cause a crease in the sheathing.
- Make sure that the excess length of cables is properly secured to avoid excess bends, interference issues, and airflow restriction.
- To prevent component damage and potential signal interference, make sure that all cables are in their appropriate routing position before installing a new component and before closing up the server after hardware installation/maintenance.

When disconnecting cables

- Grip the body of the cable connector. Do not pull on the cable itself because this action can damage the internal wires of the cable or the pins on the port.
- If a cable does not disconnect easily, check for any release latch that must be pressed to disconnect the cable.

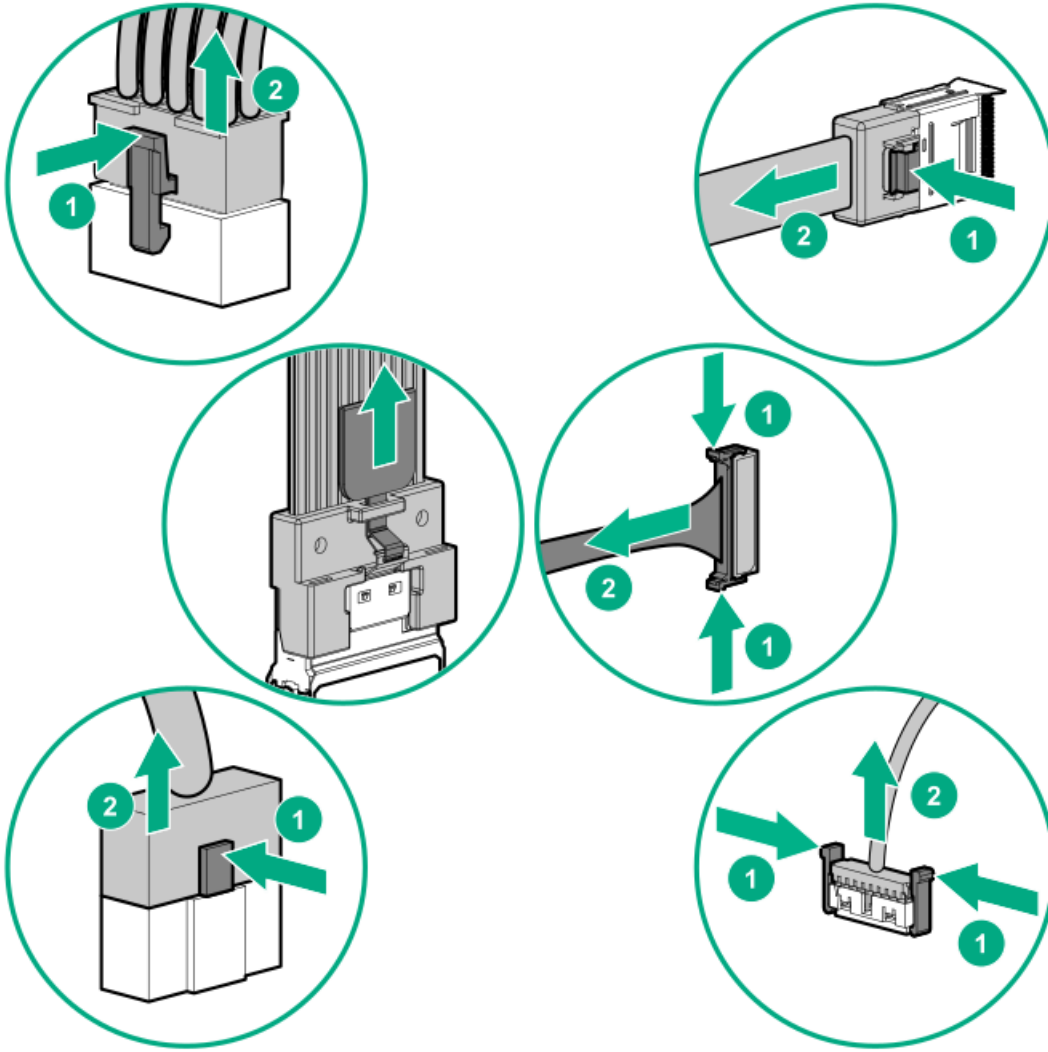

- Remove cables that are no longer being used. Retaining them inside the server can restrict airflow. If you intend to use the removed cables later, label and store them for future use.

Power cabling

Use the following tables to find cabling information and diagrams.

Table 36: Power cables

Cable description	Cable part number	From	To
PWR, 1x5 to 2x4, LFF, 240mm	<u>P14341-001</u>	Backplane	System board
PWR, 1x5 to 2x4, LFF, 400mm	<u>P14342-001</u>	Backplane	System board
PWR, 1x5 to 2x4 + x, LFF, 400mm	<u>P14343-001</u>	Backplane	System board
PWR, 2x3 to 2x3, SFF	<u>P14345-001</u>	Backplane	System board
PWR, 2x5 to 2x3 + 2x4 Midplane	<u>P14346-001</u>	Backplane	System board
PWR, 4LFF/8SFF	869825-001	Backplane	System board
I/O Wire to Board, FRONT	P14312-001	Backplane	System board

Cable routing: Front 8SFF power cabling

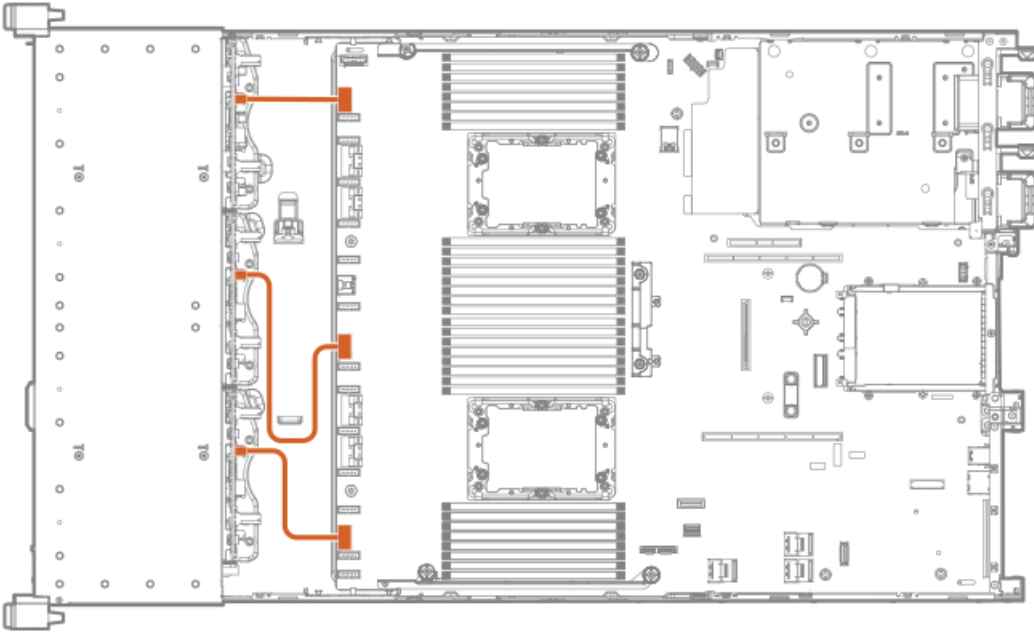

Cable routing: Front 12LFF power cabling

Box 1

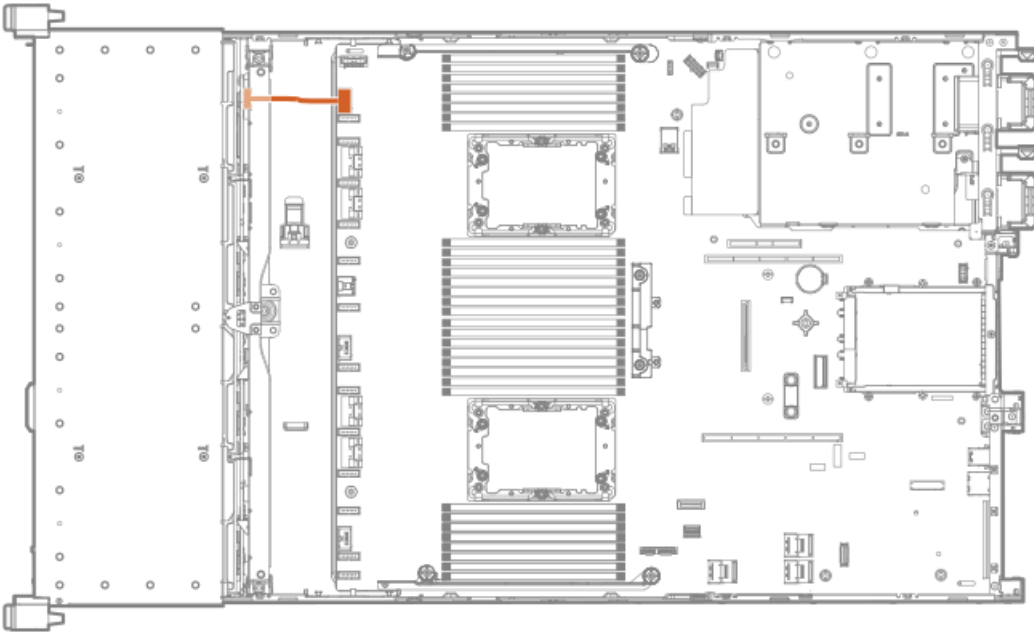

Box 2

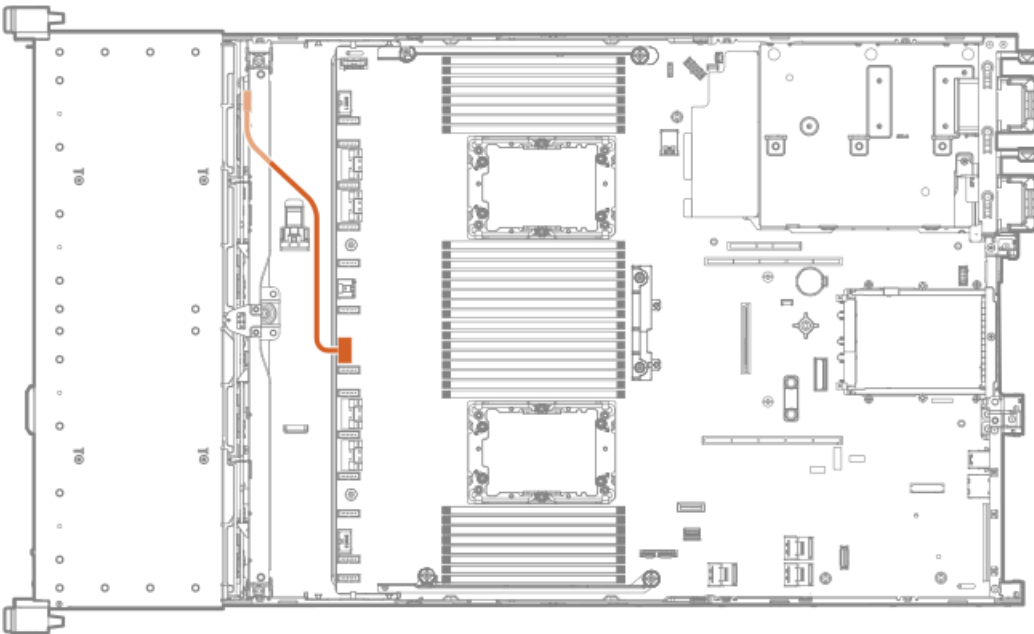

Box 3



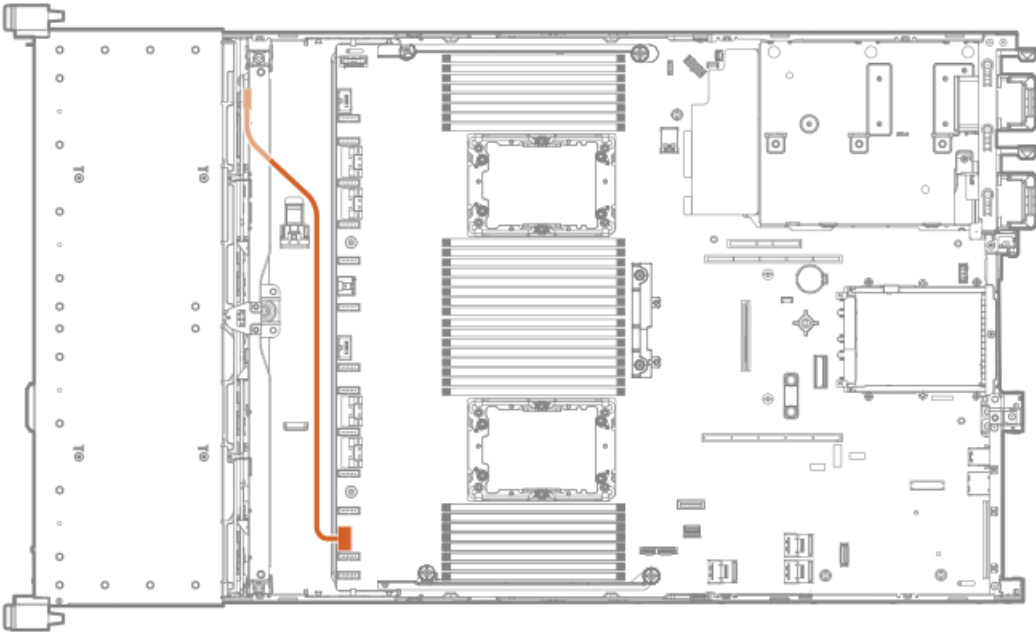

Cable routing: Midplane power cabling

8SFF midplane shown

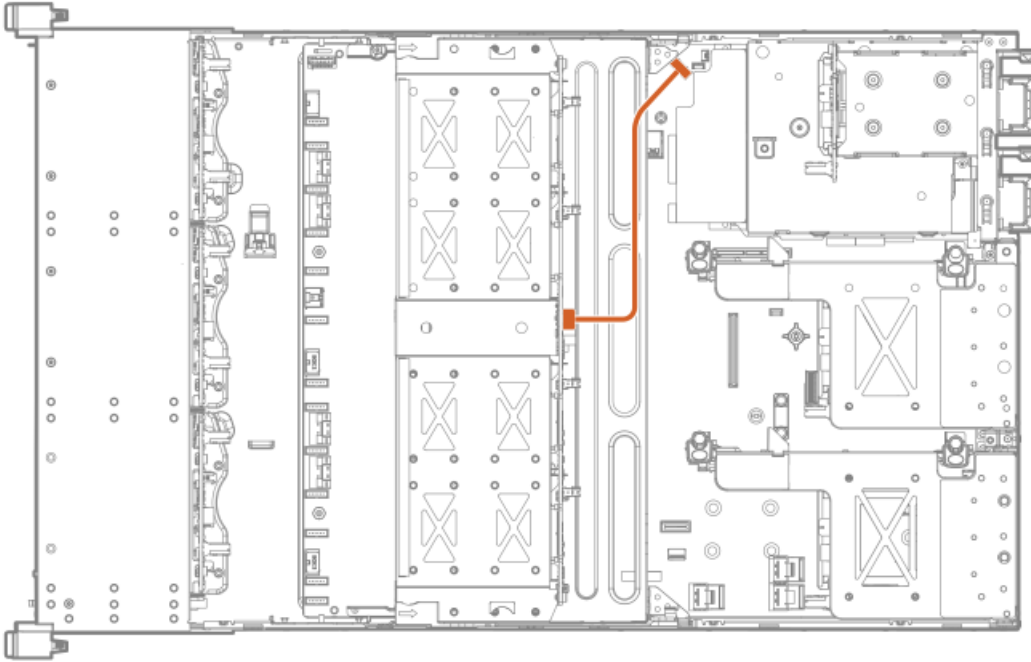

Cable routing: Front 2SFF side-by-side power cabling

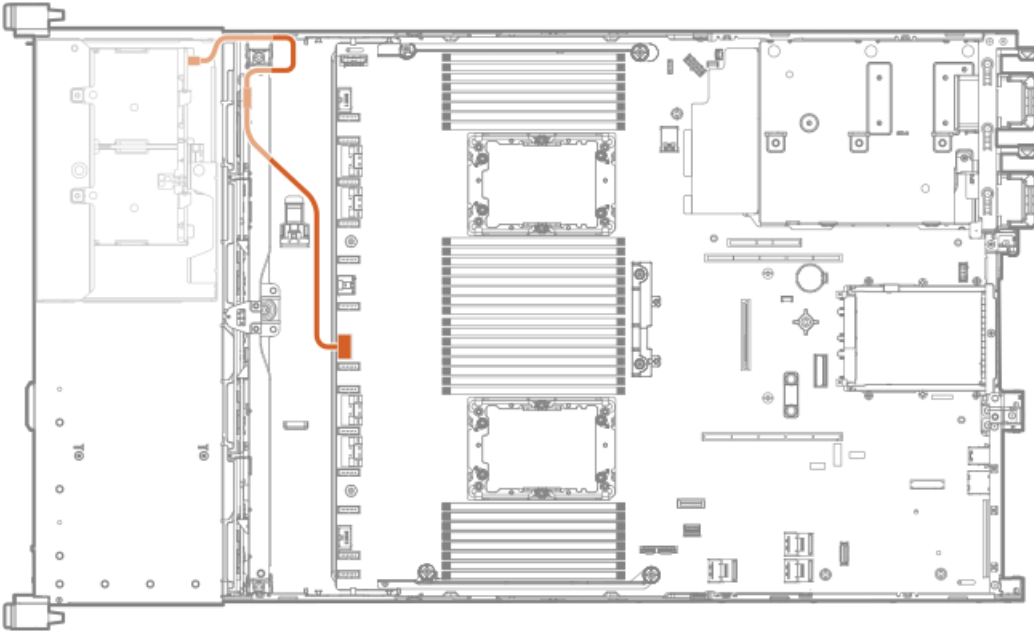

Cable routing: Rear 2SFF power cabling

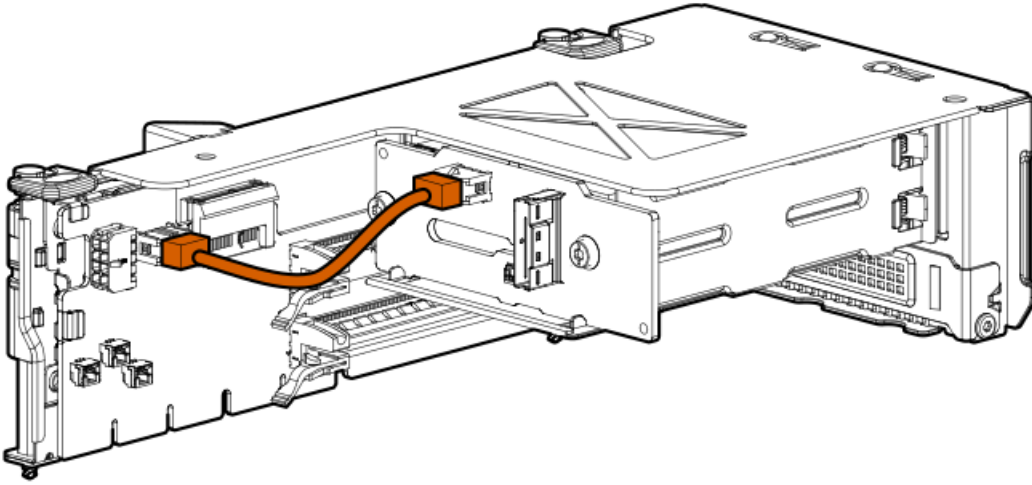

Cabling diagrams

Use the following tables to find cabling information and diagrams.

Table 4: Cable kits

Option kit	Cable part number*	From	To
2SFF stacked	P22903-001	2SFF box 6	AROC to NVMe adapter
2SFF stacked	P22761-001	2SFF stacked	Type-a controller
8SFF SAS/SATA	776402-001	Box 1/2	Type-a/p controller
	747568-001	Box 3	Type-a/p controller
	P14335-001	Box 1/2/3	Type-a/p controller
8NVMe	P22345-001	Box 1/2	System board
		Port 1 and 2	Port 1A-B/2A-B
	P22346-001	Box 2/3 Port 3-4	System board Port 1B/2B
	P22347-001	Box 2/3	Type-a controller
		Port 3	
8SFF midplane	P14334-001	Box 7 Ports 1-4	Type-p controller
8NVMe midplane	P14329-001	Box 7 Port 1	Type-p controller
NVMe direct connect	P14331-001	Box 2	Type-a/p controller
		Ports 1-2	
	P14332-001	Box 2 Ports 3-4	Type-a/p controller
	P14330-001	Box 1/3	Primary/tertiary type-p controller
		Ports 3-4	
	P14333-001	Box 1/3	Primary/tertiary type-p controller
		Ports 1-2	
	P14326-001	Box 2	Type-p controller
		Ports 1-4	
	P14327-001	Box 1	Type-p controller
		Ports 1-4	
	P14328-001	Box 1	Tertiary type-p controller
		2SFF stacked	
	P14324-001	Box 2	Secondary type-p controller
		Ports 1-2	
	P14325-001	Box 2 Ports 3-4	Secondary type-p controller

Option kit	Cable part number*	From	To
	P14320-001	Box 3 Ports 1-4	Primary riser
	P14321-001	Box 3 Ports 1-4	Primary type-p controller
	P14322-001	Box 2 Ports 1-4	System board Port 1A-B/2A-B
OCP enablement kit	P14337-001	OCP adapter	Primary riser
	P14339-001	OCP adapter	Secondary riser

Table 5: Front I/O

Cable description	Cable part number	From	To
Display port + USB 2.0	P14314-001	Component	System board
USB to USB Port	P14315-001	Component	System board
Optical Disk Drive, SATA	P14316-001	Component	System board
Serial port	P14317-001	Component	System board

Table 36: Power cables

Cable description	Cable part number	From	To
I/O Wire to Board, FRONT	P14312-001	Backplane	System board
PWR, 1x5 to 2x4, LFF, 240mm	P14341-001	Backplane	System board
PWR, 1x5 to 2x4, LFF, 400mm	P14342-001	Backplane	System board
PWR, 1x5 to 2x4 + x, LFF, 400mm	P14343-001	Backplane	System board
PWR, 2x3 to 2x3, SFF	P14345-001	Backplane	System board
PWR, 2x5 to 2x3 + 2x4	P14346-001	Backplane	System board
PWR, 4LFF/8SFF	869825-001	Backplane	System board

Cable routing: 2NVMe box 6 to AROC NVMe adapter

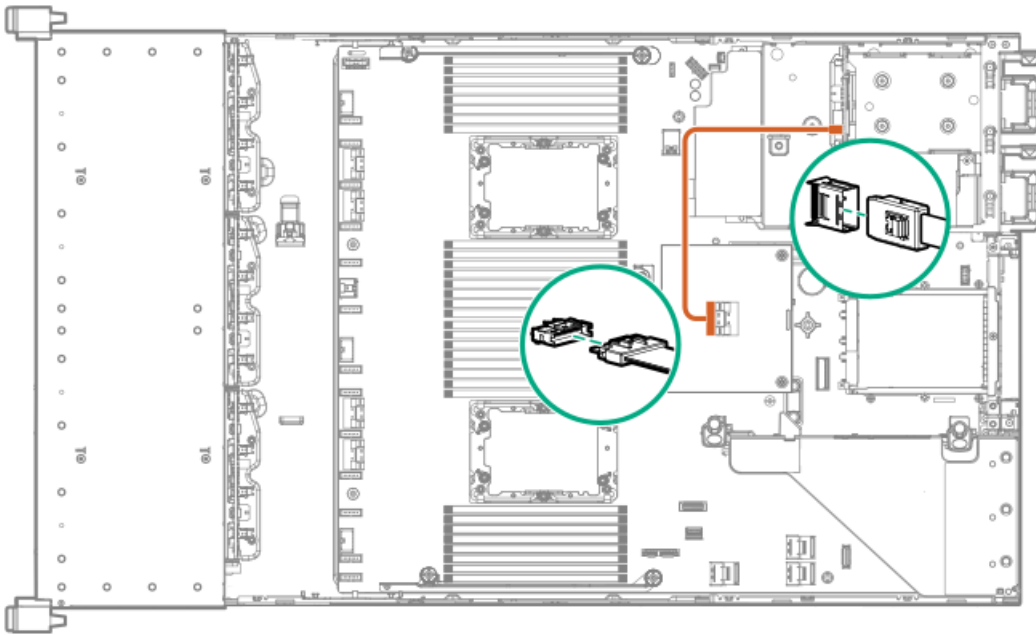

Cable routing: 6NVMe box 3 to 3-port primary riser

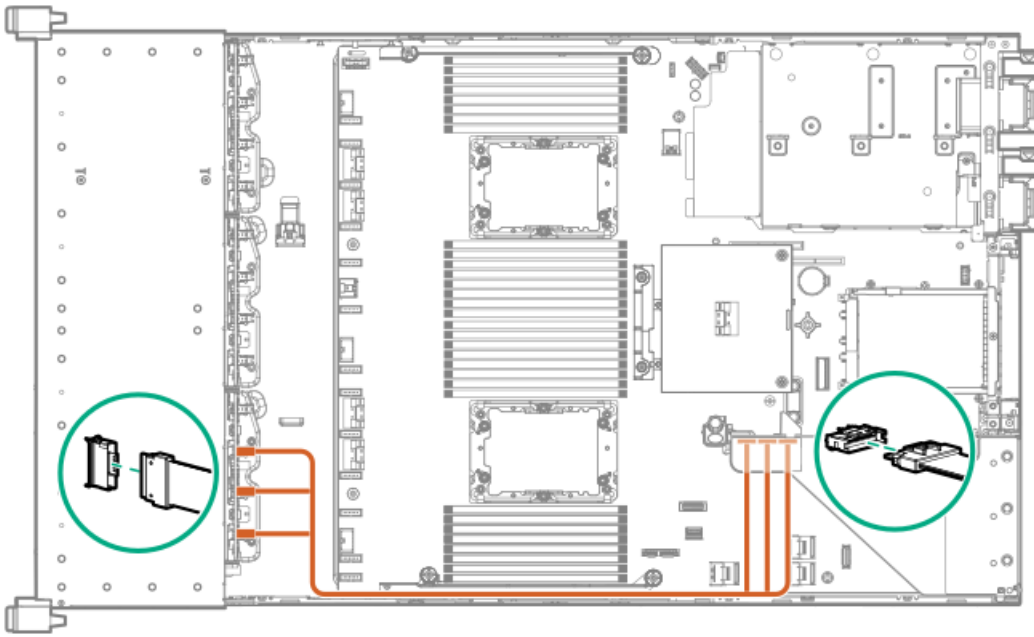

Cable routing: 8NVMe balanced box 2 to system board

8NVMe direct attach

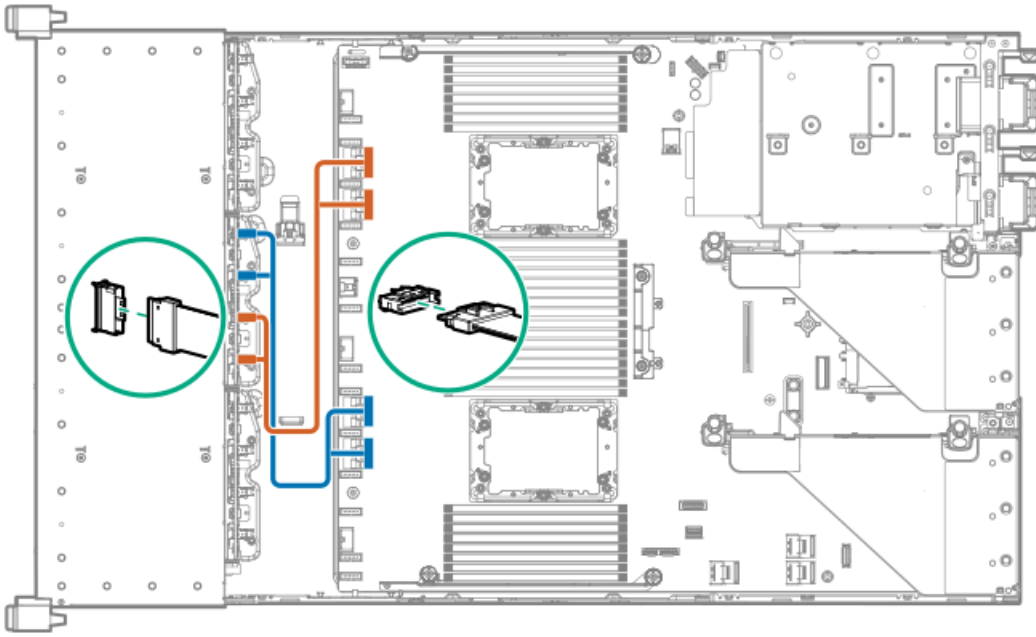

Cable routing: 8NVMe P2 box 1 to system board/secondary riser

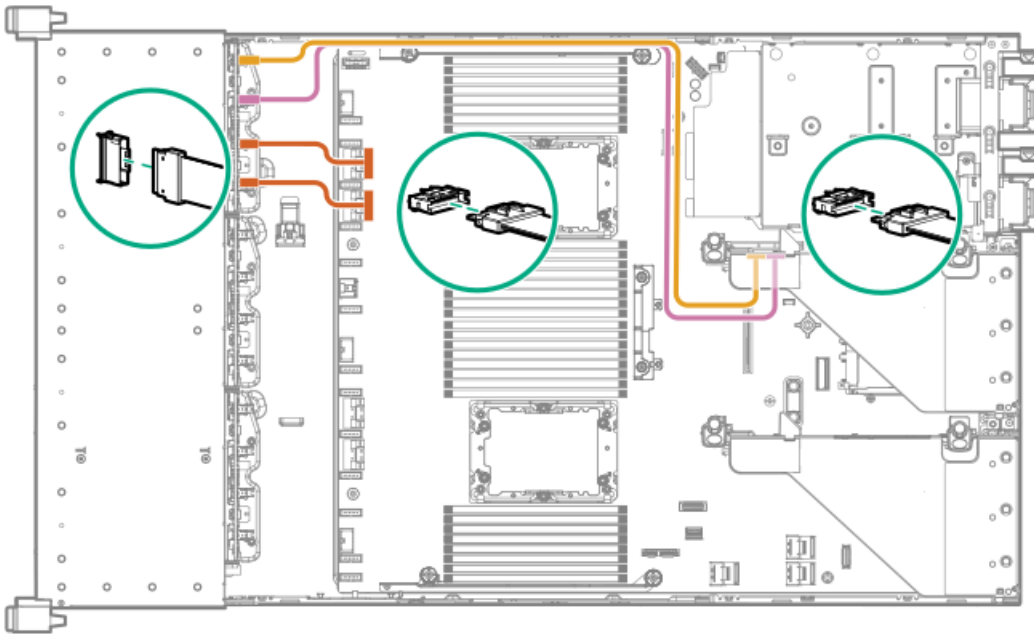

Cable routing: 8NVMe P1 box 3 to system board/primary riser

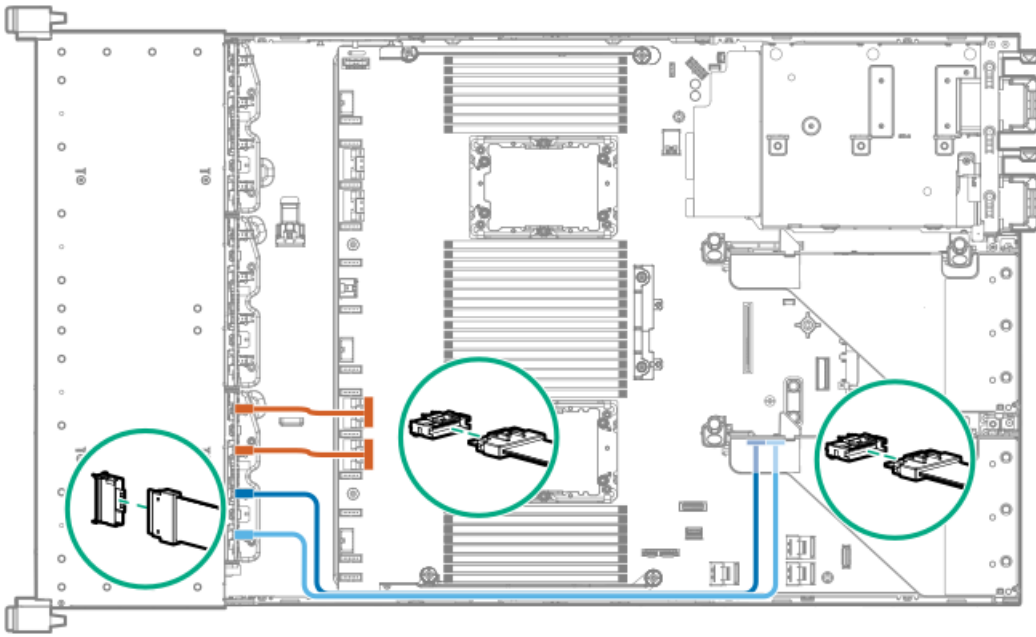

Cable routing: 12NVMe BAL P1 box 2+3 to system board/primary riser/OCP NVMe adapter/Type-a controller

12NVMe P1

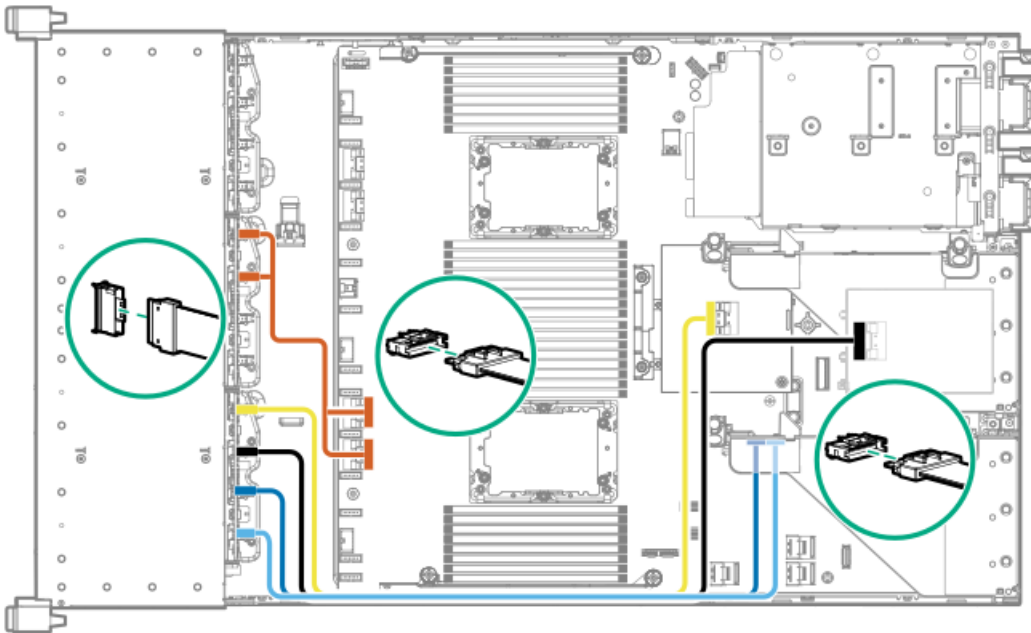

Cable routing: 12NVMe BAL P2 box 1+2 to system board/4-port NVMe secondary riser

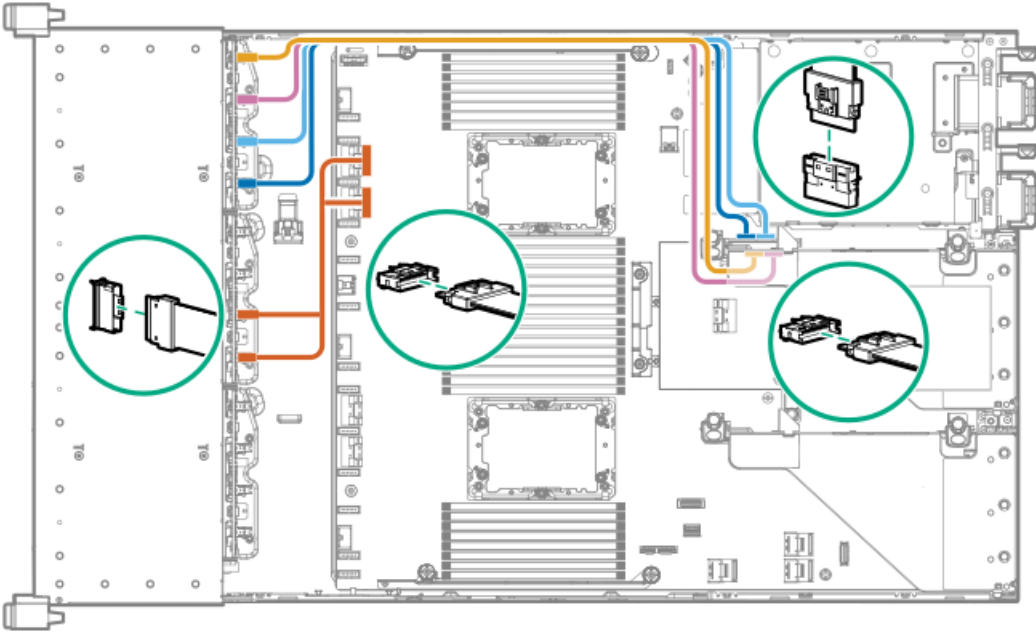

Cable routing: 12NVMe DIFF P1 box 2+3 to system board/4-port NVMe primary riser

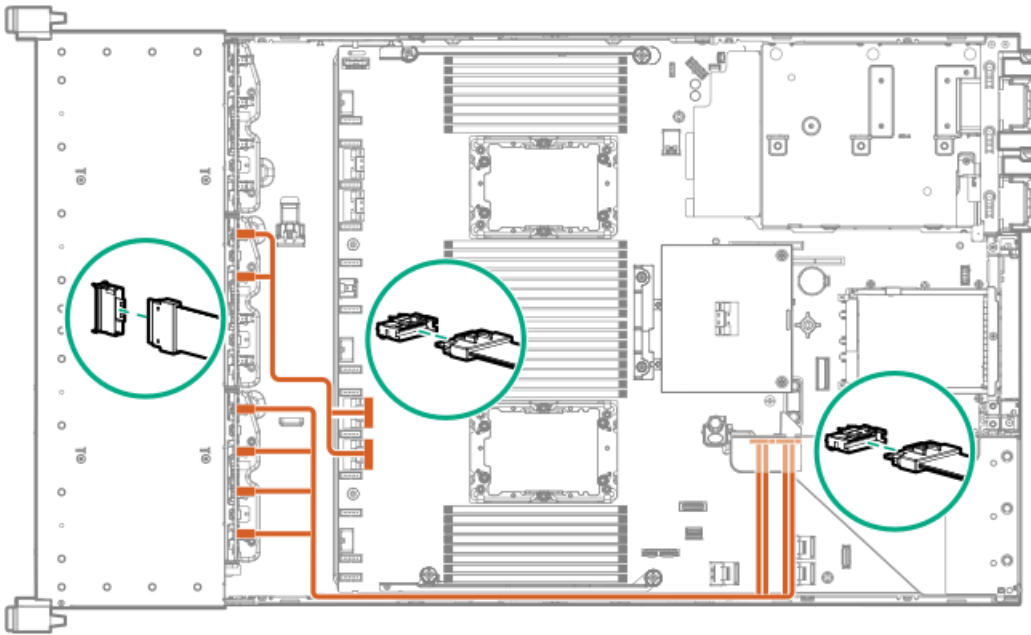

Cable routing: 12NVMe DIFF P1 box 1+2 to system board/4-port NVMe secondary riser

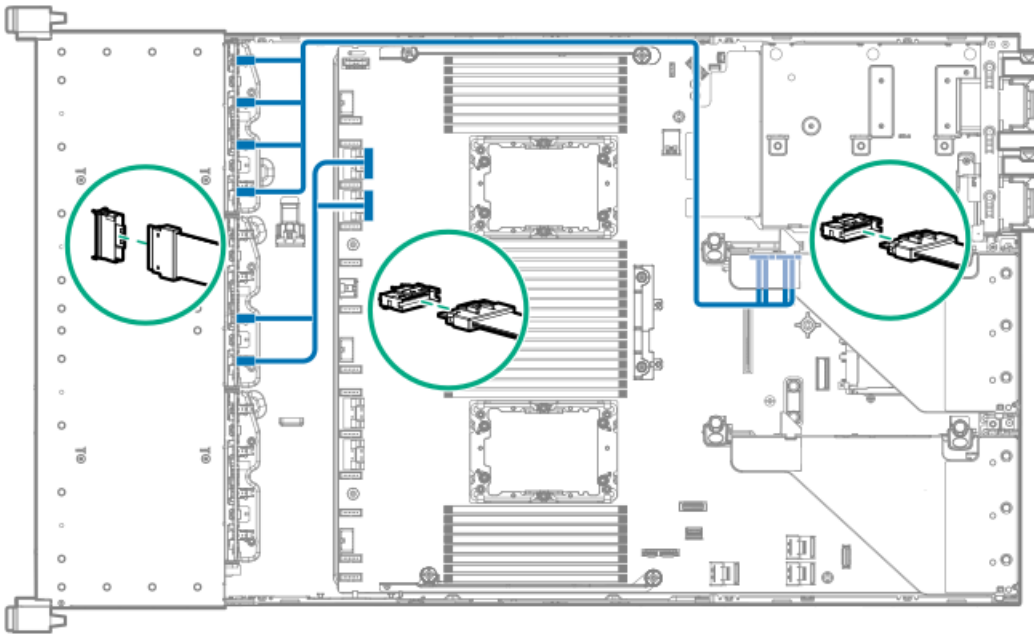

Cable routing: 24NVMe Balanced

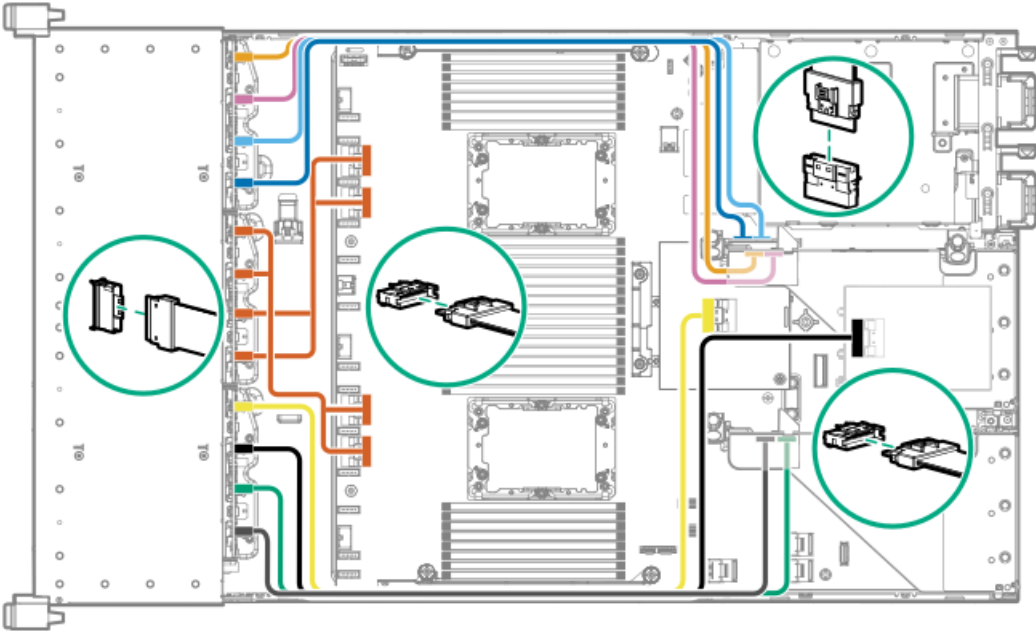

Cable routing: 24NVMe Differential

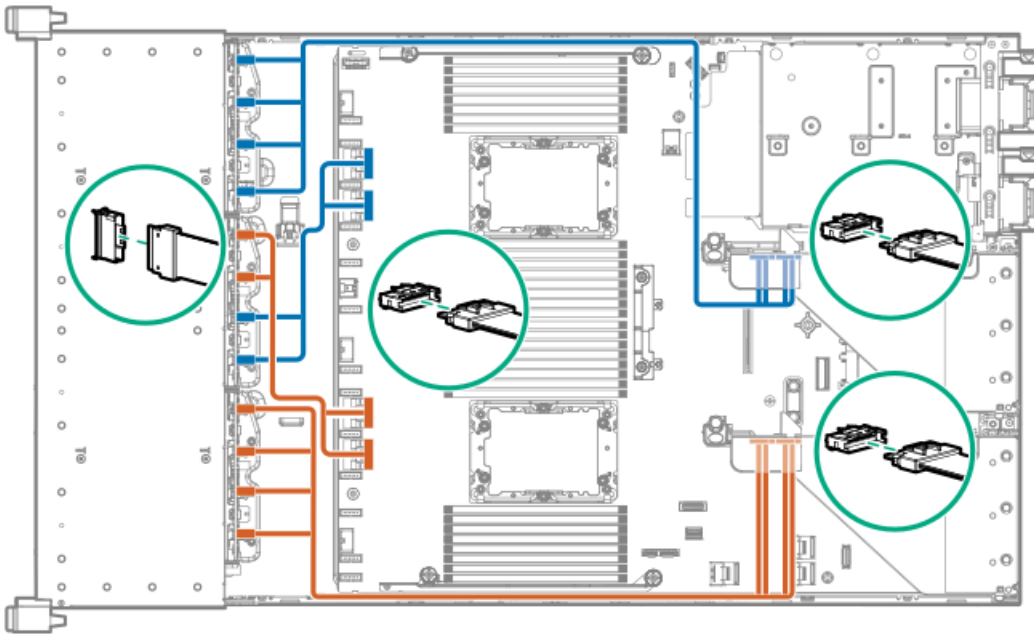

Cable routing: 8NVMe box 3 to 4-port primary riser

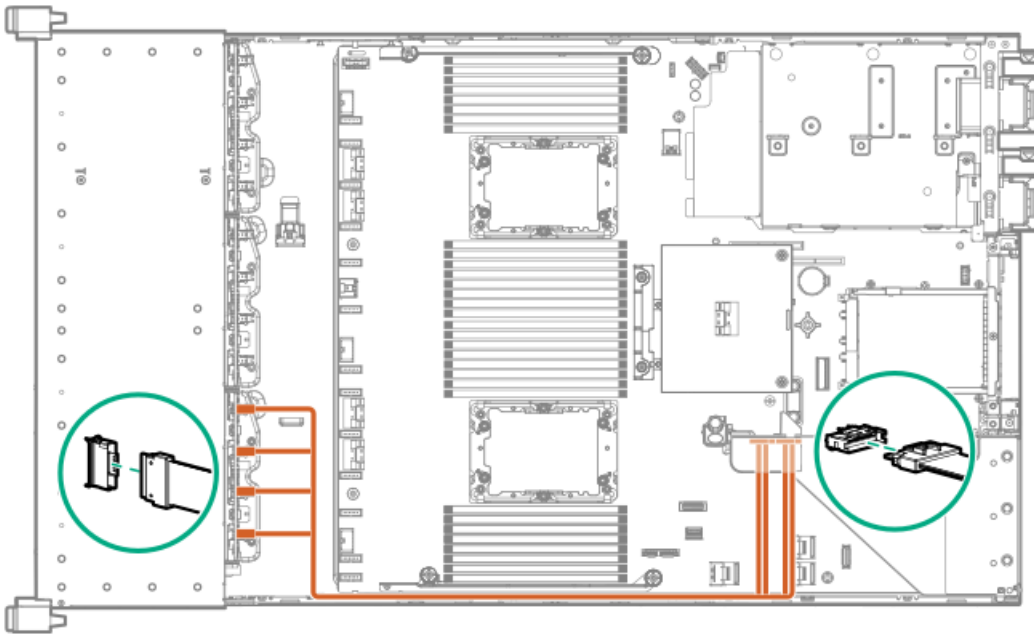

Cable routing: 8NVMe box 1 to 4-port secondary riser

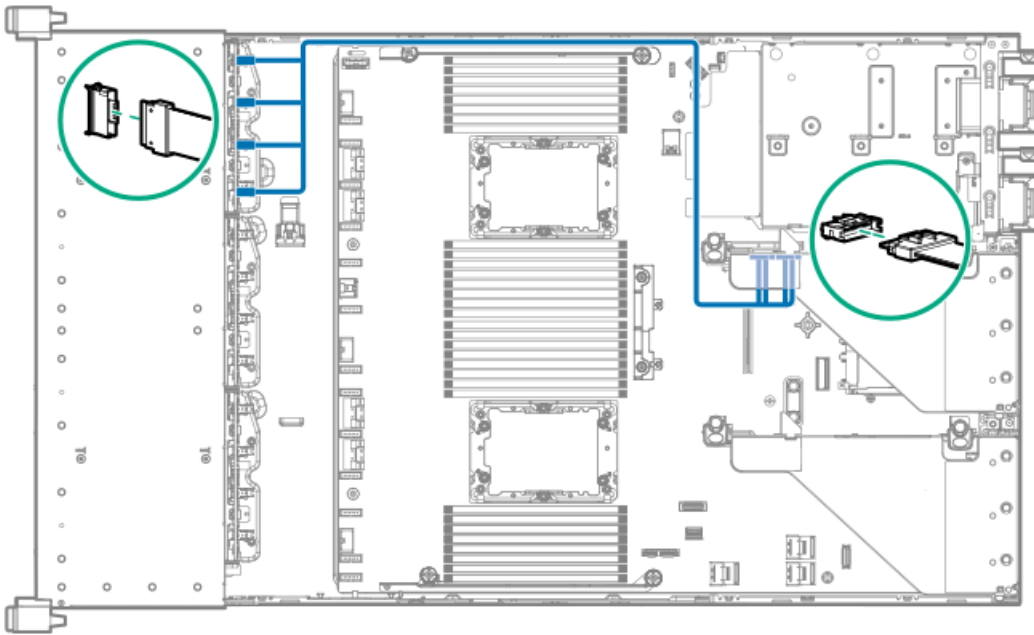

Cable routing: 8NVMe box 1+2 to type-a controller

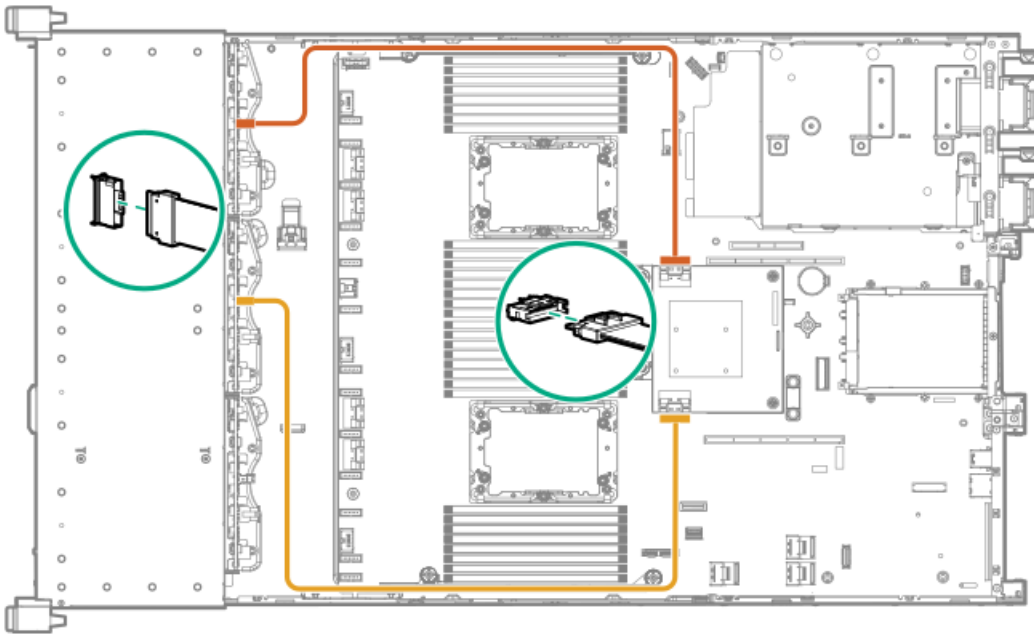

Cable routing: 8SFF box 2 to type-a controller

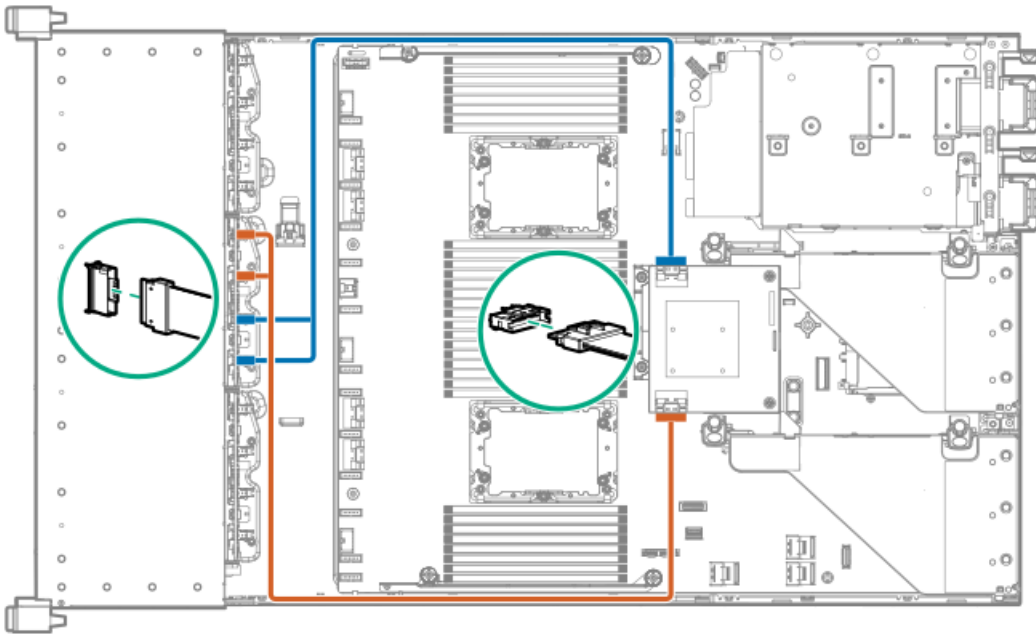

Cable routing: 8SFF box 3 to 2-port primary type-p controller

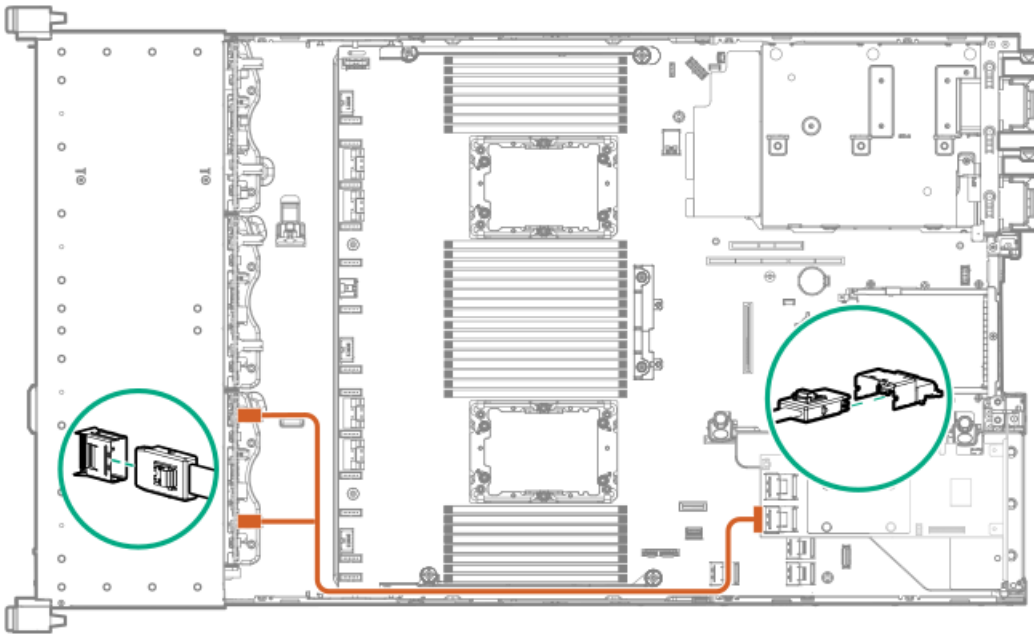

Cable routing: 8SFF box 2 to 2-port primary type-p controller

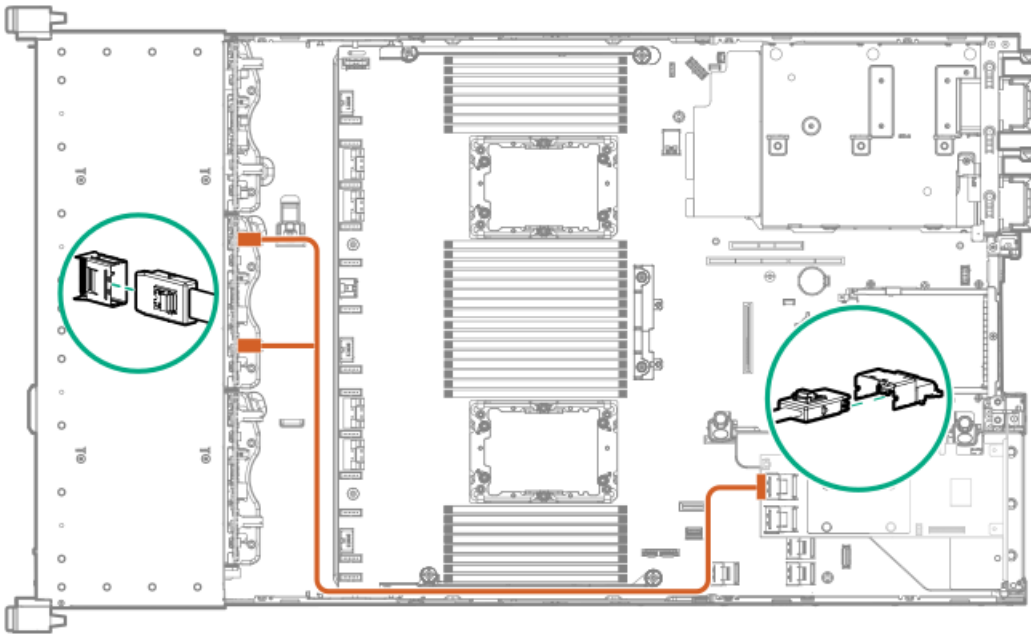

Cable routing: 2SFF side-by-side to primary type-p controller

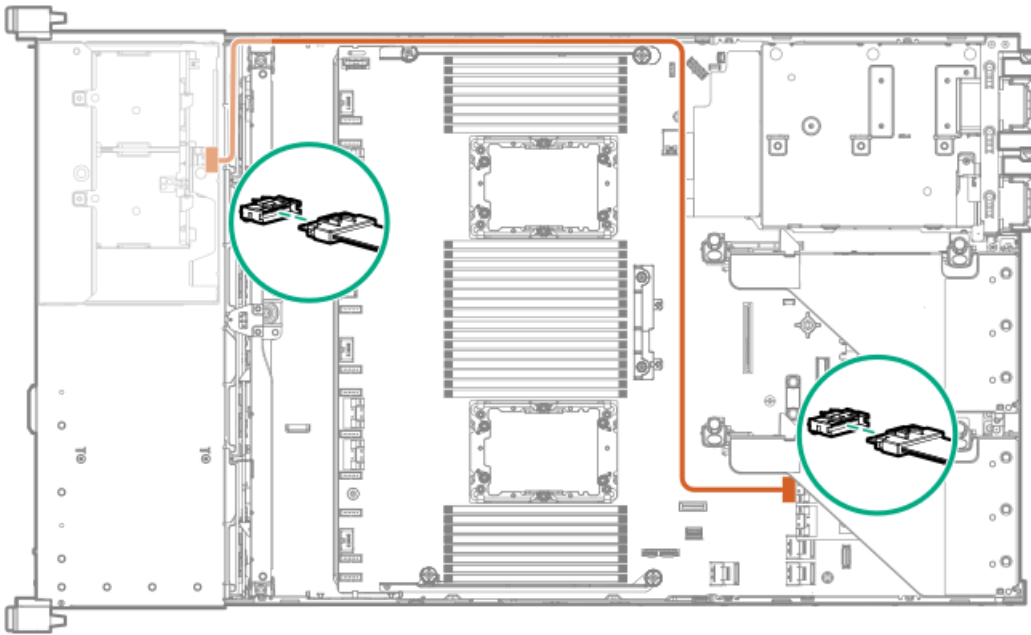

Cable routing: 8SFF 4-port box 1 to 4-port secondary type-p controller

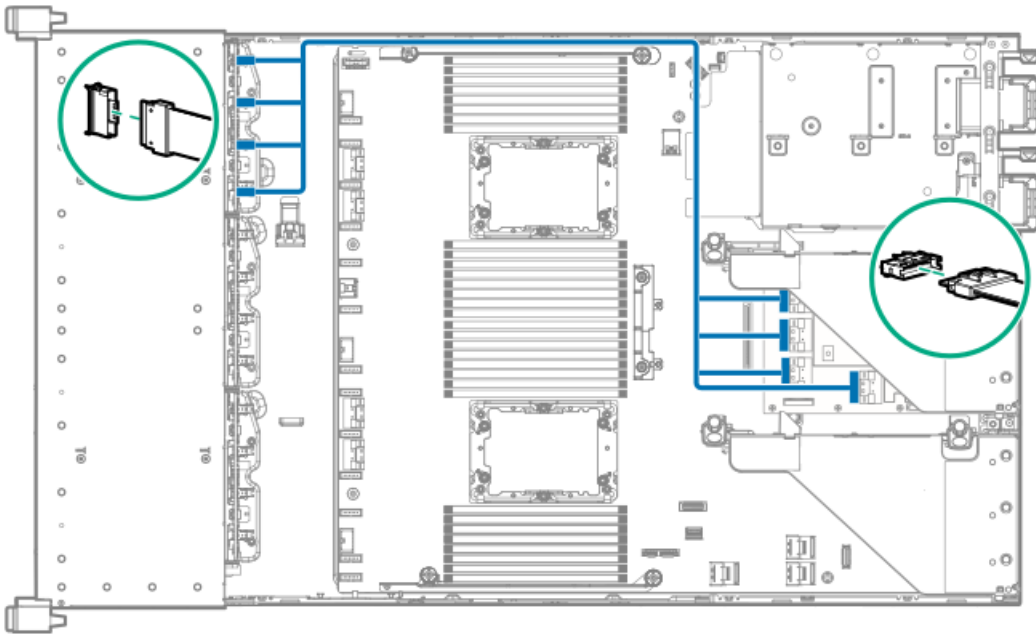

Cable routing: 8SFF 4-port box 2 to 4-port primary type-p controller

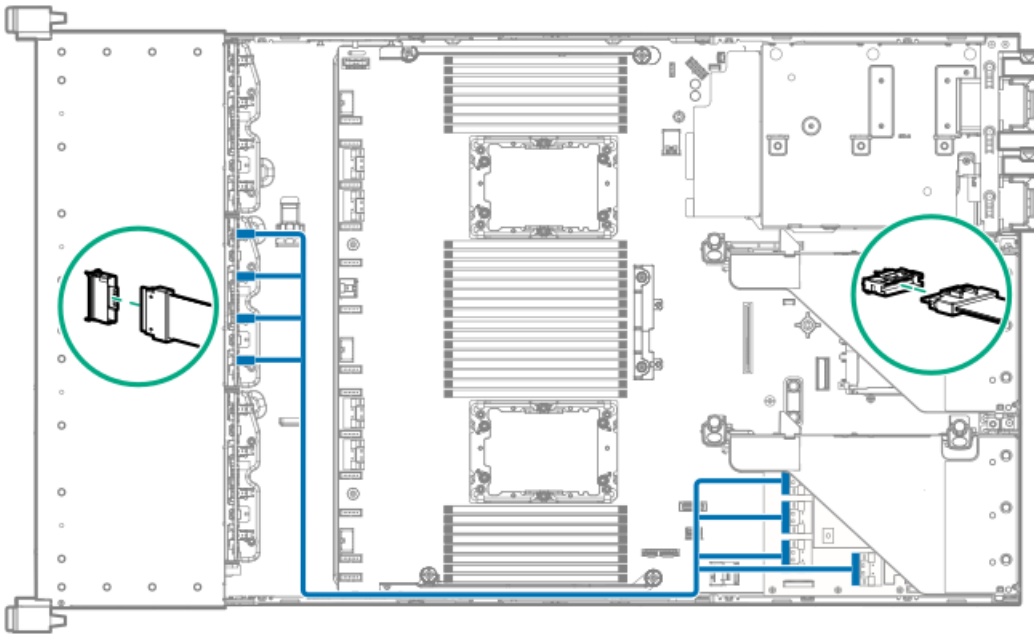

Cable routing: 8SFF 4-port box 3 to 4-port primary type-p controller

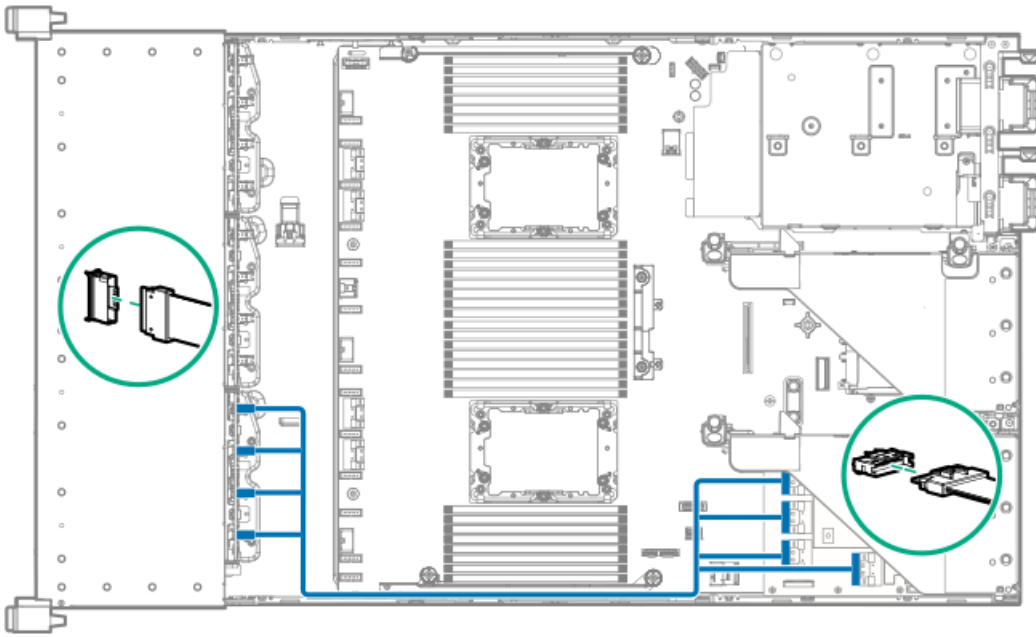

Cable routing: 8SFF box 1+2+3 to 4-port secondary type-p controller

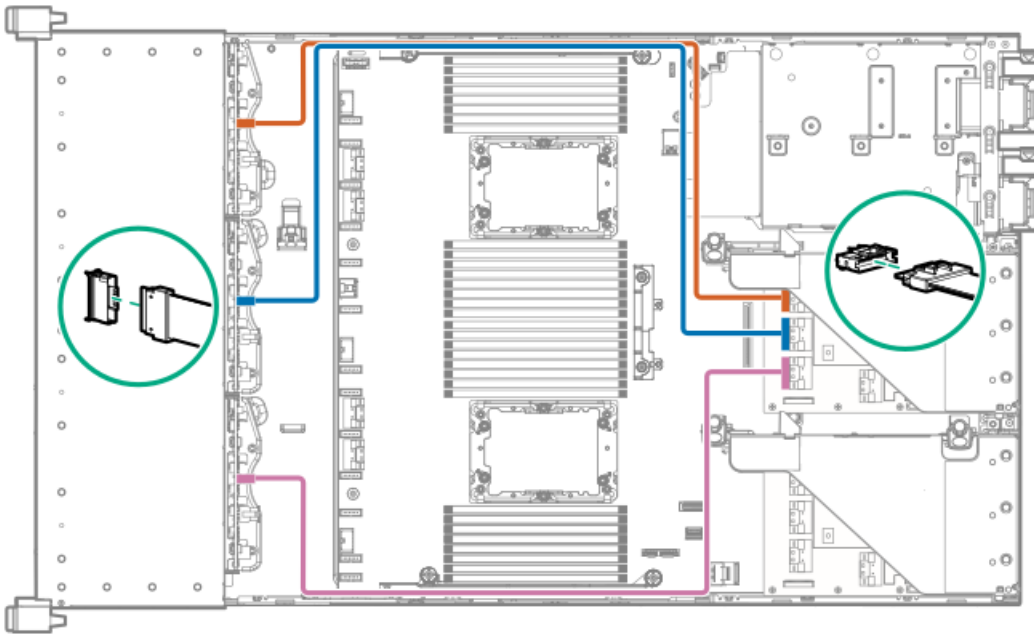

Cable routing: 8SFF box 1+2+3 to 4-port primary type-p controller

8SFF

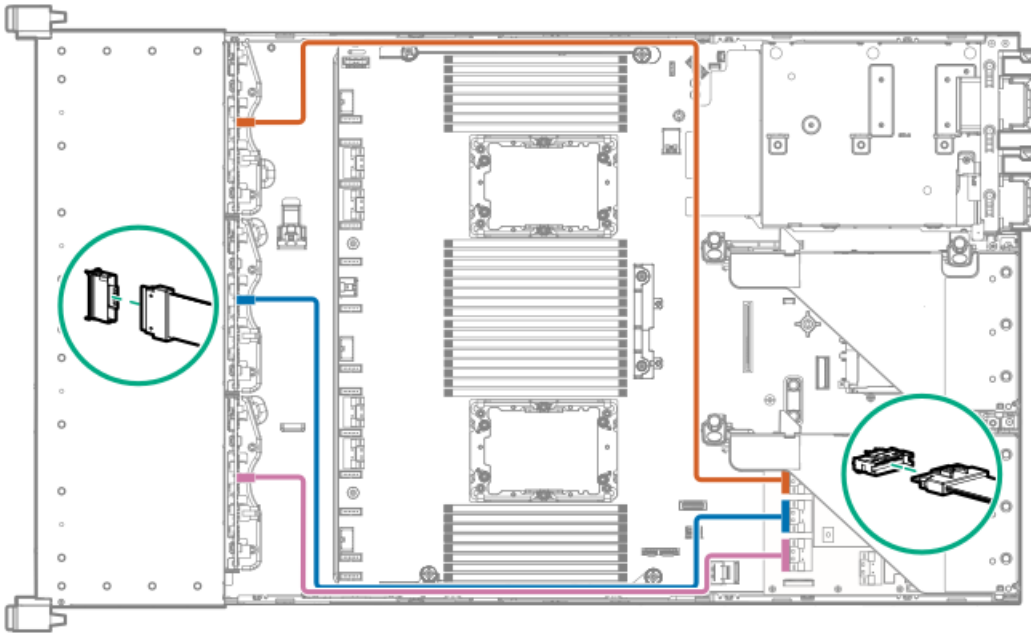

Cable routing: 4LFF SAS/SATA box 7 to 4-port type-a controller

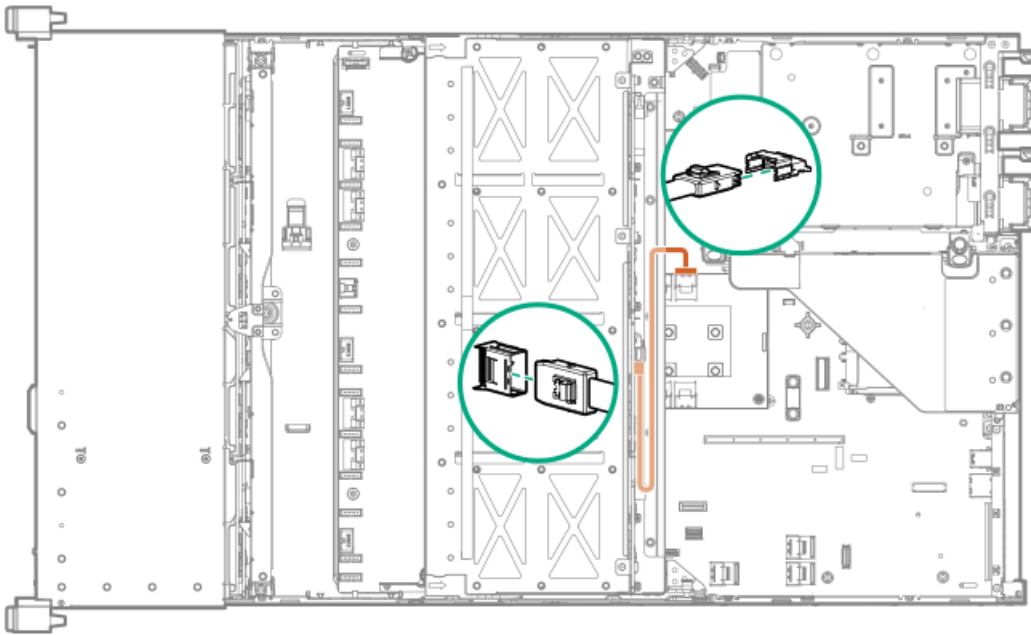

Cable routing: Front I/O cabling

SFF Universal Media Bay Display Port

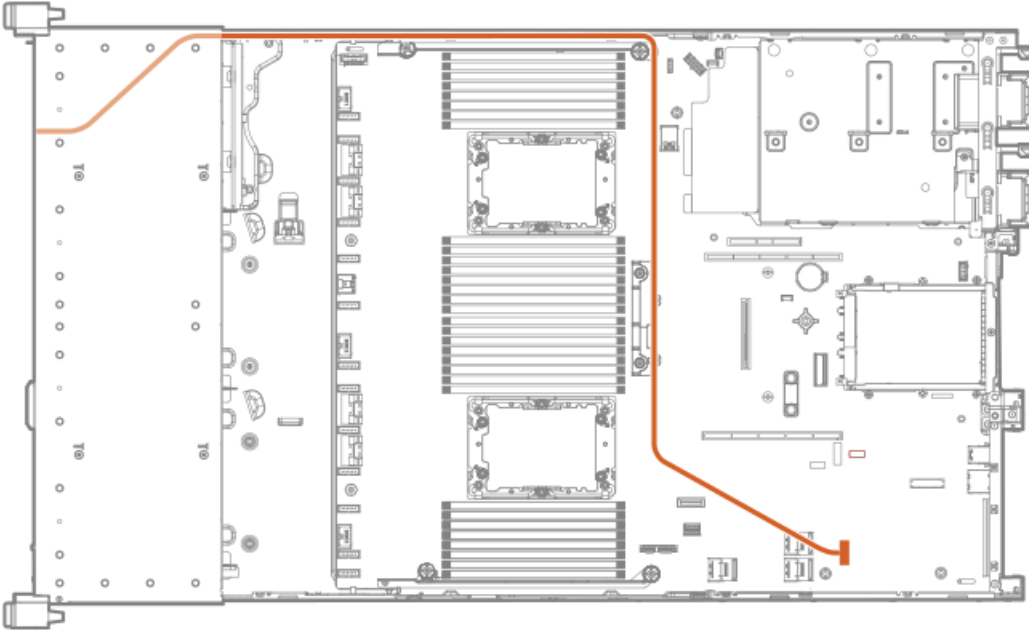

SFF Universal Media Bay USB to system board

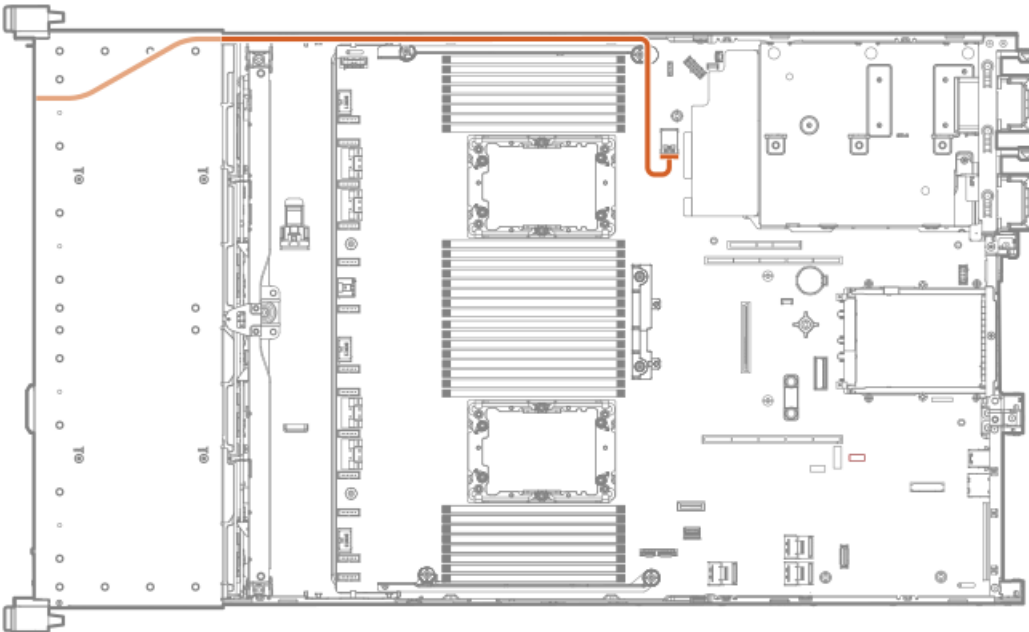

SFF Universal Media Bay optical disk drive



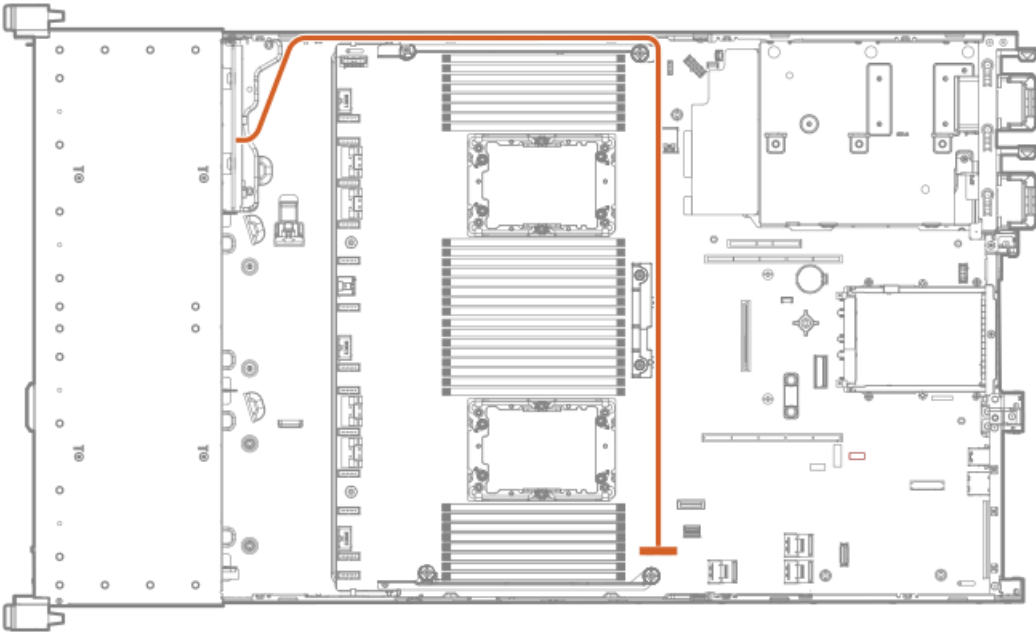

SFF/LFF power switch

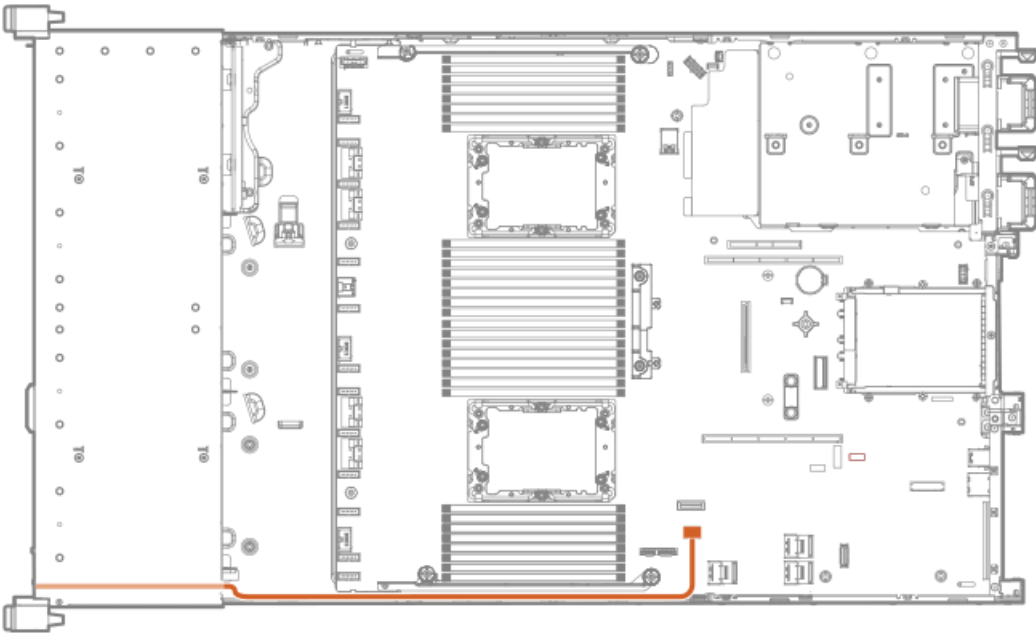

SFF/LFF Systems Insight Display



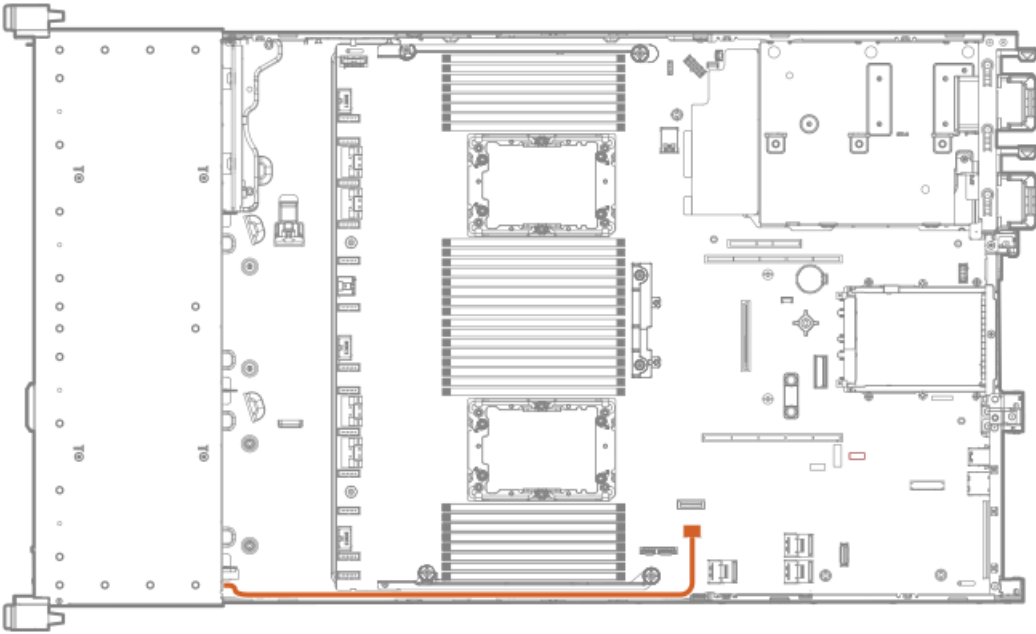

LFF optical disk drive

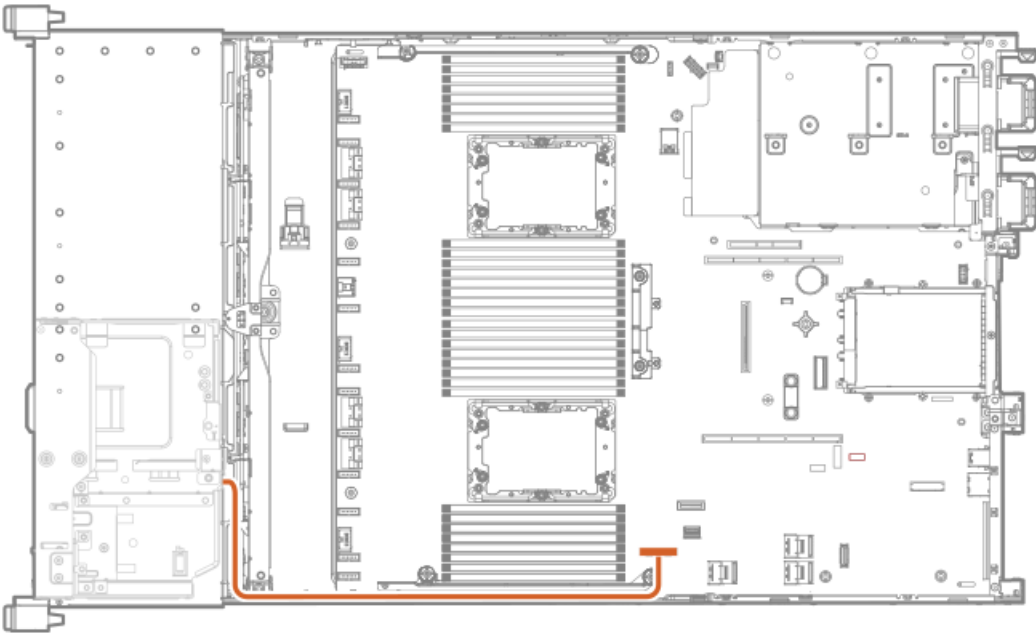

LFF display port



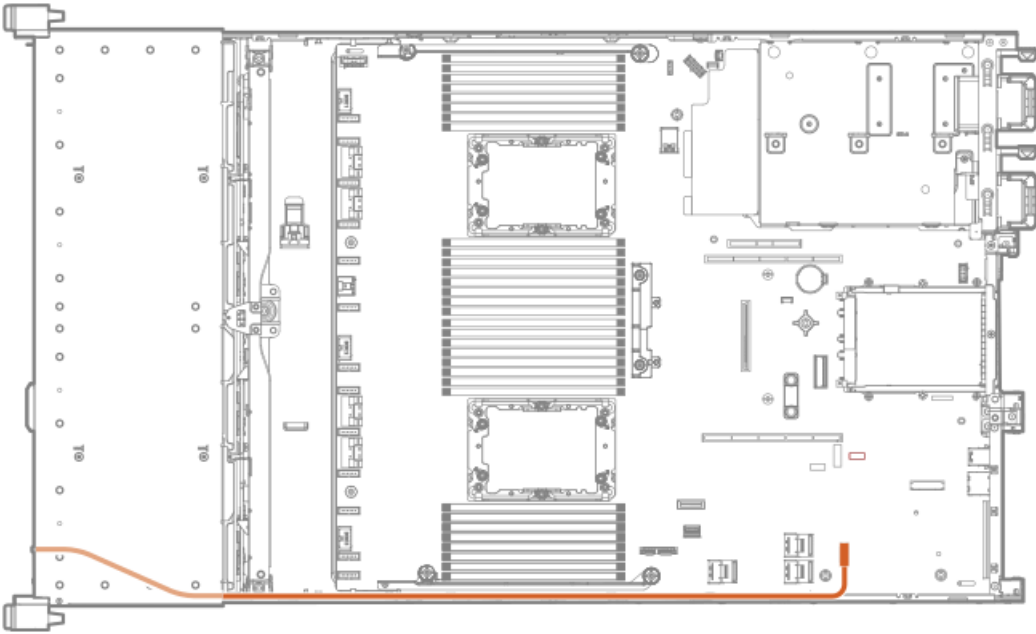

LFF power switch module

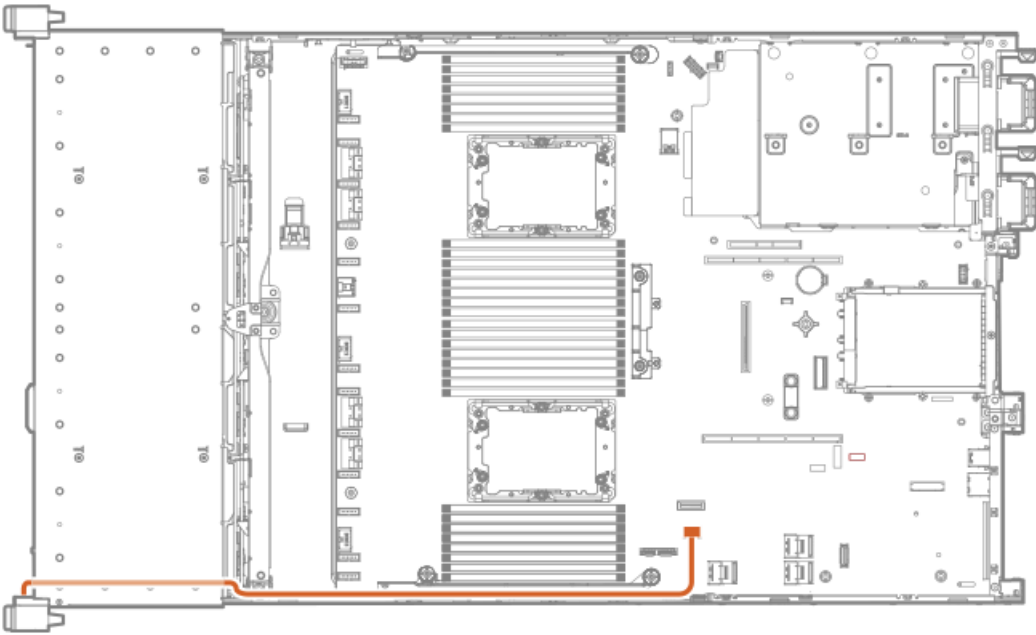

Cable routing: Serial port

Standard

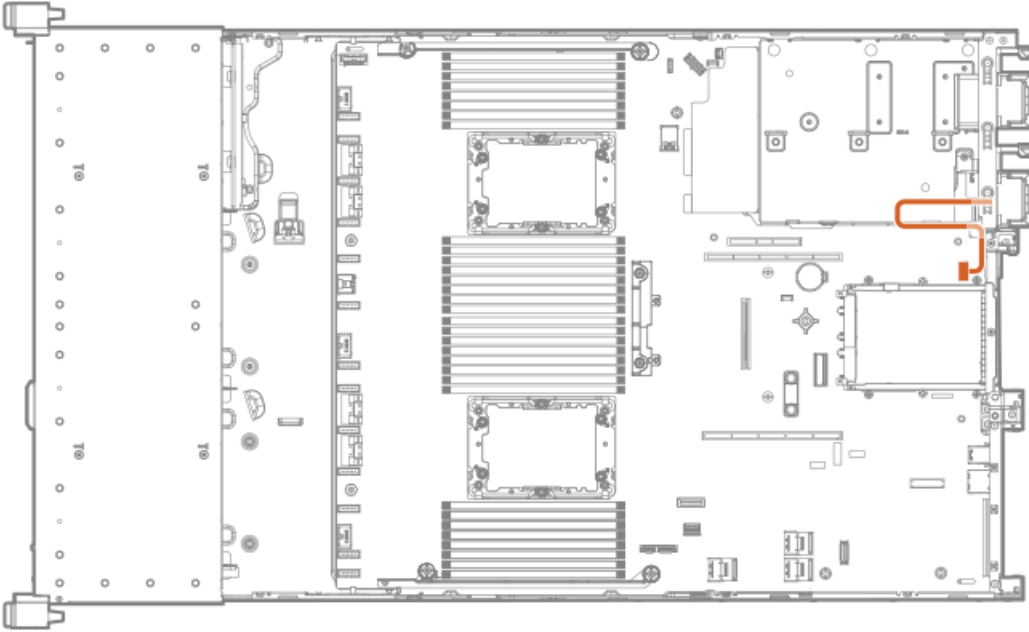

Tertiary riser

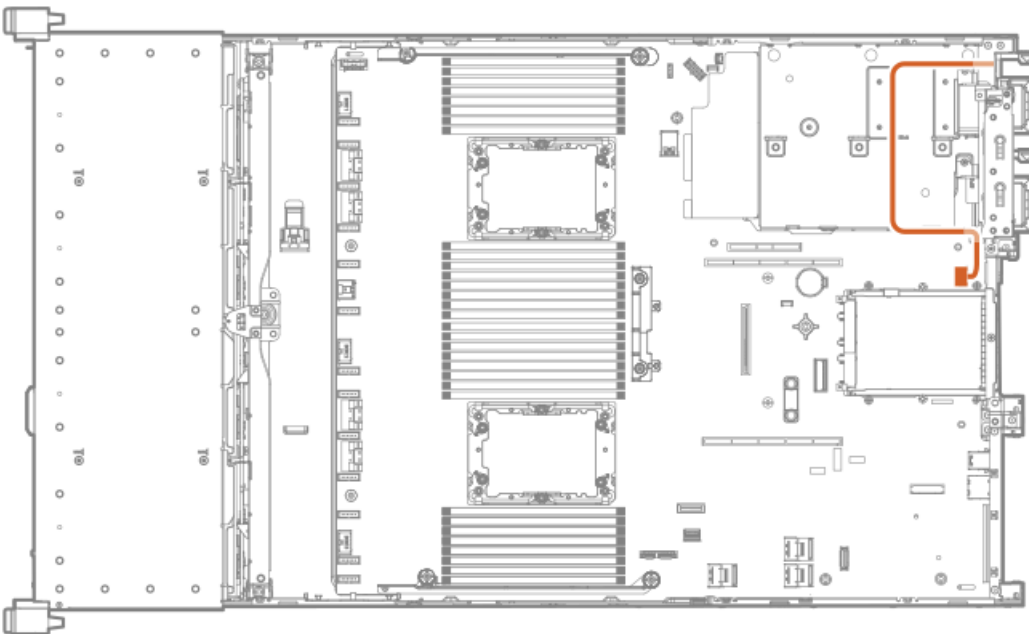

Cable routing: OCP NVMe enablement

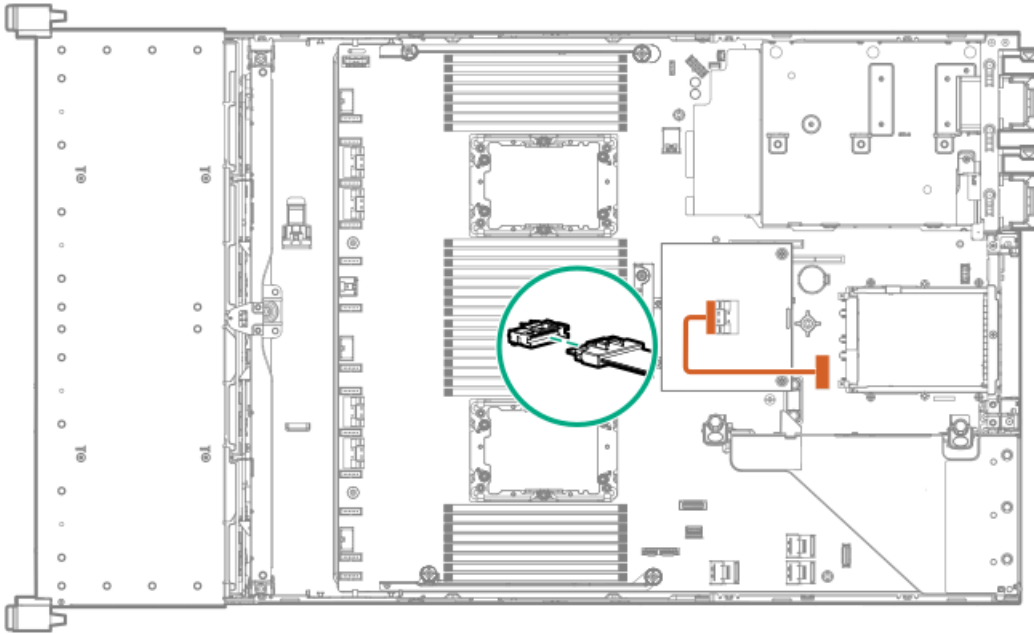

Server mode

The software and configuration utilities presented in this section operate in online mode, offline mode, or in both modes.

<u>Software or configuration utility</u>	<u>Server mode</u>
<u>Active Health System</u>	Online and Offline
<u>HPE iLO 5</u>	Online and Offline
<u>HPE Smart Storage Administrator</u>	Online and Offline
<u>iLO RESTful API</u>	Online and Offline
<u>Intelligent Provisioning</u>	Online and Offline
<u>Scripting Toolkit for Windows and Linux</u>	Online
<u>Service Pack for ProLiant</u>	Online and Offline
<u>Smart Update Manager</u>	Online and Offline
<u>UEFI System Utilities</u>	Offline

Product QuickSpecs

For more information about product features, specifications, options, configurations, and compatibility, see the product QuickSpecs on the Hewlett Packard Enterprise website (<https://www.hpe.com/info/qs>).



Active Health System Viewer

Active Health System Viewer (AHSV) is an online tool used to read, diagnose, and resolve server issues quickly using AHS uploaded data. AHSV provides Hewlett Packard Enterprise recommended repair actions based on experience and best practices. AHSV provides the ability to:

- Read server configuration information
- View Driver/Firmware inventory
- Review Event Logs
- Respond to Fault Detection Analytics alerts
- Open new and update existing support cases

Active Health System

The Active Health System monitors and records changes in the server hardware and system configuration.

The Active Health System provides:

- Continuous health monitoring of over 1600 system parameters
- Logging of all configuration changes
- Consolidated health and service alerts with precise time stamps
- Agentless monitoring that does not affect application performance

For more information about the Active Health System, see the iLO user guide at the following website:
<https://www.hpe.com/support/ilo-docs>.

Active Health System data collection

The Active Health System does not collect information about your operations, finances, customers, employees, or partners.

Examples of information that is collected:

- Server model and serial number
- Processor model and speed
- Storage capacity and speed
- Memory capacity and speed
- Firmware/BIOS and driver versions and settings

The Active Health System does not parse or change OS data from third-party error event log activities (for example, content created or passed through the OS).

Active Health System Log

The data collected by the Active Health System is stored in the Active Health System Log. The data is logged securely, isolated from the operating system, and separate from customer data. Host resources are not consumed in the collection and logging of Active Health System data.

When the Active Health System Log is full, new data overwrites the oldest data in the log.

It takes less than 5 minutes to download the Active Health System Log and send it to a support professional to help you resolve an issue.

When you download and send Active Health System data to Hewlett Packard Enterprise, you agree to have the data used for analysis, technical resolution, and quality improvements. The data that is collected is managed according to the privacy statement, available at <https://www.hpe.com/info/privacy>.

You can upload the log to HPE InfoSight for Servers to view the log data or create a support case for servers under a valid warranty or support contract. For more information, see the HPE InfoSight for Servers documentation at the following website: <https://www.hpe.com/support/infosight-servers-docs>.



HPE iLO 5

iLO 5 is a remote server management processor embedded on the system boards of supported HPE servers and compute modules. iLO enables the monitoring and controlling of servers from remote locations. iLO management is a powerful tool that provides multiple ways to configure, update, monitor, and repair servers remotely.

For more information about iLO, see the iLO user guide at the following website: <https://www.hpe.com/support/ilo-docs>.



iLO Federation

iLO Federation enables you to manage multiple servers from one system using the iLO web interface.

When configured for iLO Federation, iLO uses multicast discovery and peer-to-peer communication to enable communication between the systems in iLO Federation groups.

When you navigate to one of the iLO Federation pages, a data request is sent from the iLO system running the web interface to its peers, and from those peers to other peers until all data for the selected iLO Federation group is retrieved.

iLO supports the following features:

- Group health status—View server health and model information.
- Group virtual media—Connect URL-based media for access by a group of servers.
- Group power control—Manage the power status of a group of servers.
- Group power capping—Set dynamic power caps for a group of servers.
- Group firmware update—Update the firmware of a group of servers.
- Group license installation—Enter a license key to activate iLO licensed features on a group of servers.
- Group configuration—Add iLO Federation group memberships for multiple iLO systems.

Any user can view information on iLO Federation pages, but a license is required for using the following features: Group virtual media, Group power control, Group power capping, Group configuration, and Group firmware update.

For more information about iLO Federation, see the iLO user guide at the following website: <https://www.hpe.com/support/ilo-docs>.

iLO RESTful API

iLO includes the iLO RESTful API, which is Redfish API conformant. The iLO RESTful API is a management interface that server management tools can use to perform configuration, inventory, and monitoring tasks by sending basic HTTPS operations (GET, PUT, POST, DELETE, and PATCH) to the iLO web server.

To learn more about the iLO RESTful API, see the Hewlett Packard Enterprise website (<https://www.hpe.com/support/restfulinterface/docs>).

For specific information about automating tasks using the iLO RESTful API, see libraries and sample code at <https://www.hpe.com/info/redfish>.

 For more information, watch the [Redfish & How it works with HPE Server Management](#) video.

RESTful Interface Tool

The RESTful Interface Tool (iLOREST) is a scripting tool that allows you to automate HPE server management tasks. It provides a set of simplified commands that take advantage of the iLO RESTful API. You can install the tool on your computer for remote use or install it locally on a server with a Windows or Linux Operating System. The RESTful Interface Tool offers an interactive mode, a scriptable mode, and a file-based mode similar to CONREP to help decrease automation times.

For more information, see the following website: <https://www.hpe.com/info/resttool>.

iLO Amplifier Pack

iLO Amplifier Pack is an advanced server inventory, firmware and driver update solution that enables rapid discovery, detailed inventory reporting, firmware, and driver updates by leveraging iLO advanced functionality. iLO Amplifier Pack performs rapid server discovery and inventory for thousands of supported servers for the purpose of updating firmware and drivers at scale.

For more information about iLO Amplifier Pack, see the iLO Amplifier Pack User Guide at the following website:

<https://www.hpe.com/support/ilo-ap-ug-en>.



Integrated Management Log

The IML records hundreds of events and stores them in an easy-to-view form. The IML timestamps each event with one-minute granularity.

You can view recorded events in the IML in several ways, including the following:

- From within HPE SIM
- From within the UEFI System Utilities
- From within the Embedded UEFI shell
- From within the iLO web interface

Intelligent Provisioning

Intelligent Provisioning is a single-server deployment tool embedded in ProLiant servers and HPE Synergy compute modules. Intelligent Provisioning simplifies server setup, providing a reliable and consistent way to deploy servers.

Intelligent Provisioning prepares the system for installing original, licensed vendor media and Hewlett Packard Enterprise-branded versions of OS software. Intelligent Provisioning also prepares the system to integrate optimized server support software from the Service Pack for ProLiant (SPP). SPP is a comprehensive systems software and firmware solution for ProLiant servers, server blades, their enclosures, and HPE Synergy compute modules. These components are preloaded with a basic set of firmware and OS components that are installed along with Intelligent Provisioning.

i IMPORTANT:

HPE ProLiant XL servers do not support operating system installation with Intelligent Provisioning, but they do support the maintenance features. For more information, see "Performing Maintenance" in the Intelligent Provisioning user guide and online help.

After the server is running, you can update the firmware to install additional components. You can also update any components that have been outdated since the server was manufactured.

To access Intelligent Provisioning:

- Press F10 from the POST screen and enter either Intelligent Provisioning or HPE Rapid Setup Software.
- From the iLO web interface using Lifecycle Management. Lifecycle Management allows you to access Intelligent Provisioning without rebooting your server.

Management security

HPE ProLiant Gen10, HPE ProLiant Gen10 Plus, and HPE Apollo servers are built with some of the industry's most advanced security capabilities, out of the box, with a foundation of secure embedded management applications and firmware. The management security provided by HPE embedded management products enables secure support of modern workloads, protecting your components from unauthorized access and unapproved use. The range of embedded management and optional software and firmware available with the iLO Advanced license provides security features that help ensure protection, detection, and recovery from advanced cyber attacks. For more information, see the HPE Gen10 and Gen10 Plus Security Reference Guide at [Hewlett Packard Enterprise Support Center](#).

Scripting Toolkit for Windows and Linux

The STK for Windows and Linux is a server deployment product that delivers an unattended automated installation for high-volume server deployments. The STK is designed to support ProLiant servers. The toolkit includes a modular set of utilities and important documentation that describes how to apply these tools to build an automated server deployment process.

The STK provides a flexible way to create standard server configuration scripts. These scripts are used to automate many of the manual steps in the server configuration process. This automated server configuration process cuts time from each deployment, making it possible to scale rapid, high-volume server deployments.

For more information or to download the STK, see the [Hewlett Packard Enterprise website](#).

HPE Message Passing Interface

The HPE Message Passing Interface is an MPI development environment designed to enable the development and optimization of high performance computing (HPC) Linux applications. The HPE Message Passing Interface leverages a scalable MPI library and takes advantage of the underlying server infrastructure by boosting performance of existing MPI applications on Hewlett Packard Enterprise HPC clusters without requiring recompilation. For more information, see the HPE Message Passing Interface documentation on the Hewlett Packard Enterprise website (<https://www.hpe.com/software/mpi>).

HPE Performance Cluster Manager

HPE Performance Cluster Manager is a point of contact for the deployment, system management, monitoring, and reporting on the HPE cluster system. For more information, see the HPE Performance Cluster Manager documentation on the Hewlett Packard Enterprise website (<https://www.hpe.com/software/hpcm>).

UEFI System Utilities

The UEFI System Utilities is embedded in the system ROM. Its features enable you to perform a wide range of configuration activities, including:

- Configuring system devices and installed options.
- Enabling and disabling system features.
- Displaying system information.
- Selecting the primary boot controller or partition.
- Configuring memory options.
- Launching other preboot environments.

HPE servers with UEFI can provide:

- Support for boot partitions larger than 2.2 TB. Such configurations could previously only be used for boot drives when using RAID solutions.
- Secure Boot that enables the system firmware, option card firmware, operating systems, and software collaborate to enhance platform security.
- UEFI Graphical User Interface (GUI)
- An Embedded UEFI Shell that provides a preboot environment for running scripts and tools.
- Boot support for option cards that only support a UEFI option ROM.

Selecting the boot mode

This server provides two Boot Mode configurations: UEFI Mode and Legacy BIOS Mode. Certain boot options require that you select a specific boot mode. By default, the boot mode is set to UEFI Mode. The system must boot in UEFI Mode to use certain options, including:

- Secure Boot, UEFI Optimized Boot, Generic USB Boot, IPv6 PXE Boot, iSCSI Boot, NVMe Boot and Boot from URL
- Fibre Channel/FCoE Scan Policy



NOTE:

The boot mode you use must match the operating system installation. If not, changing the boot mode can impact the ability of the server to boot to the installed operating system.

Prerequisite

When booting to UEFI Mode, leave UEFI Optimized Boot enabled.

Procedure

1. From the System Utilities screen, select System Configuration > BIOS/Platform Configuration (RBSU) > Boot Options > Boot Mode.
2. Select a setting.
 - UEFI Mode (default)—Configures the system to boot to a UEFI compatible operating system.
 - Legacy BIOS Mode—Configures the system to boot to a traditional operating system in Legacy BIOS compatibility mode.
3. Save your setting.
4. Reboot the server.

Secure Boot

Secure Boot is a server security feature that is implemented in the BIOS and does not require special hardware. Secure Boot ensures that each component launched during the boot process is digitally signed and that the signature is validated against a set of trusted certificates embedded in the UEFI BIOS. Secure Boot validates the software identity of the following components in the boot process:

- UEFI drivers loaded from PCIe cards
- UEFI drivers loaded from mass storage devices
- Preboot UEFI Shell applications
- OS UEFI boot loaders

When Secure Boot is enabled:

- Firmware components and operating systems with boot loaders must have an appropriate digital signature to execute during the boot process.
- Operating systems must support Secure Boot and have an EFI boot loader signed with one of the authorized keys to boot. For more information about supported operating systems, see <https://www.hpe.com/servers/ossupport>.

You can customize the certificates embedded in the UEFI BIOS by adding or removing your own certificates, either from a management console directly attached to the server, or by remotely connecting to the server using the iLO Remote Console.

You can configure Secure Boot:

- Using the System Utilities options described in the following sections.
- Using the iLO RESTful API to clear and restore certificates. For more information, see the Hewlett Packard Enterprise website (<https://www.hpe.com/info/redfish>).
- Using the `secboot` command in the Embedded UEFI Shell to display Secure Boot databases, keys, and security reports.

Launching the Embedded UEFI Shell

Use the Embedded UEFI Shell option to launch the Embedded UEFI Shell. The Embedded UEFI Shell is a preboot command-line environment for scripting and running UEFI applications, including UEFI boot loaders. The Shell also provides CLI-based commands you can use to obtain system information, and to configure and update the system BIOS.

Prerequisites

- Embedded UEFI Shell is set to Enabled.

Procedure

1. From the System Utilities screen, select Embedded Applications > Embedded UEFI Shell.

The Embedded UEFI Shell screen appears.

2. Press any key to acknowledge that you are physically present.

This step ensures that certain features, such as disabling Secure Boot or managing the Secure Boot certificates using third-party UEFI tools, are not restricted.

3. If an administrator password is set, enter it at the prompt and press Enter.

The `Shell>` prompt appears.

4. Enter the commands required to complete your task.

5. Enter the `exit` command to exit the Shell.

HPE Smart Storage Administrator

HPE SSA is the main tool for configuring arrays on HPE Smart Array SR controllers. It exists in three interface formats: the HPE SSA GUI, the HPE SSA CLI, and HPE SSA Scripting. All formats provide support for configuration tasks. Some of the advanced tasks are available in only one format.

The diagnostic features in HPE SSA are also available in the standalone software HPE Smart Storage Administrator Diagnostics Utility CLI.

During the initial provisioning of the server or compute module, an array is required to be configured before the operating system can be installed. You can configure the array using SSA.

HPE SSA is accessible both offline (either through HPE Intelligent Provisioning or as a standalone bootable ISO image) and online:

- Accessing HPE SSA in the offline environment

i **IMPORTANT:** If you are updating an existing server in an offline environment, obtain the latest version of HPE SSA through Service Pack for ProLiant before performing configuration procedures.

Using one of multiple methods, you can run HPE SSA before launching the host operating system. In offline mode, users can configure or maintain detected and supported devices, such as optional Smart Array controllers and integrated Smart Array controllers. Some HPE SSA features are only available in the offline environment, such as setting the boot controller and boot volume.

- Accessing HPE SSA in the online environment

This method requires an administrator to download the HPE SSA executables and install them. You can run HPE SSA online after launching the host operating system.

For more information, see HPE SSA online help.



Smart Storage Administrator

SSA is the main tool for configuring arrays on these controllers. It exists in three interface formats: the SSA GUI, the SSA CLI, and SSA Scripting. All formats provide support for configuration tasks. Some of the advanced tasks are available in only one format.

The diagnostic features in SSA are also available in the standalone software Smart Storage Administrator Diagnostics Utility CLI.

- **Accessing SSA in the offline environment:** Using one of multiple methods, you can run SSA before launching the host operating system. In offline mode, users can configure or maintain detected and supported HPE ProLiant devices, such as optional controllers and integrated controllers. Some SSA features are only available in the offline environment, such as setting the boot controller or performing split-mirror operations.
- **Accessing SSA in the online environment:** This method requires an administrator to download the SSA executables and install them. You can run SSA online after launching the host operating system.

HPE InfoSight for servers

The HPE InfoSight portal is a secure web interface hosted by HPE that allows you to monitor supported devices through a graphical interface.

HPE InfoSight for servers:

- Combines the machine learning and predictive analytics of HPE InfoSight with the health and performance monitoring of Active Health System (AHS) and HPE iLO to optimize performance and predict and prevent problems
- Provides automatic collection and analysis of the sensor and telemetry data from AHS to derive insights from the behaviors of the install base to provide recommendations to resolve problems and improve performance

For more information on getting started and using HPE InfoSight for servers, go to: <https://www.hpe.com/info/infosight-servers-docs>.

USB support

Hewlett Packard Enterprise Gen10 and Gen10 Plus servers support all USB operating speeds depending on the device that is connected to the server.



External USB functionality

Hewlett Packard Enterprise provides external USB support to enable local connection of USB devices for server administration, configuration, and diagnostic procedures.

For additional security, external USB functionality can be disabled through USB options in UEFI System Utilities.

Redundant ROM support

The server enables you to upgrade or configure the ROM safely with redundant ROM support. The server has a single ROM that acts as two separate ROM images. In the standard implementation, one side of the ROM contains the current ROM program version, while the other side of the ROM contains a backup version.



NOTE: The server ships with the same version programmed on each side of the ROM.

Safety and security benefits

When you flash the system ROM, the flashing mechanism writes over the backup ROM and saves the current ROM as a backup, enabling you to switch easily to the alternate ROM version if the new ROM becomes corrupted for any reason. This feature protects the existing ROM version, even if you experience a power failure while flashing the ROM.

Updating firmware or system ROM

To update firmware or system ROM, use one of the following methods:

- The Firmware Update option in the System Utilities.
- The `fwupdate` command in the Embedded UEFI Shell.
- Service Pack for ProLiant (SPP)
- HPE online flash components
- Moonshot Component Pack

Service Pack for ProLiant

SPP is a systems software and firmware solution delivered as a single ISO file download. This solution uses SUM as the deployment tool and is tested and supports HPE ProLiant, HPE BladeSystem, HPE Synergy, and HPE Apollo servers and infrastructure.

SPP, along with SUM and SUT, provides Smart Update system maintenance tools that systematically update HPE ProLiant, HPE BladeSystem, HPE Synergy, and HPE Apollo servers and infrastructure.

SPP can be used in an online mode on a server running Windows, Linux, or VMware vSphere ESXi, or in an offline mode where the server is booted to an operating system included in the ISO file.

The preferred method for downloading an SPP is using the SPP Custom Download at <https://www.hpe.com/servers/spp/custom>.



Smart Update Manager

SUM is an innovative tool for maintaining and updating the firmware, drivers, and system software of HPE ProLiant, HPE BladeSystem, HPE Synergy, HPE Superdome Flex servers, and HPE Apollo servers, infrastructure, and associated options.

SUM identifies associated nodes you can update at the same time to avoid interdependency issues.

Key features of SUM include:

- Discovery engine that finds installed versions of hardware, firmware, and software on nodes.
- SUM deploys updates in the correct order and ensures that all dependencies are met before deploying an update.
- Interdependency checking.
- Automatic and step-by-step Localhost Guided Update process.
- Web browser-based user interface.
- Ability to create custom baselines and ISOs.
- Support for iLO Repository (Gen10 or later iLO 5 nodes only).
- Simultaneous firmware and software deployment for multiple remote nodes.
- Local offline firmware deployments with SPP deliverables.
- Extensive logging in all modes.



NOTE:

Support for HPE Integrity servers has been discontinued from SUM 8.x.

Integrated Smart Update Tools

Integrated Smart Update Tools (SUT) is the smart update solution for performing online firmware and driver updates. SUT is used with iLO 4, iLO 5, and with update solutions (management appliances such as iLO Amplifier Pack or HPE OneView and Smart Update Manager) to stage, install, and activate firmware and driver updates.

The solution must be installed on the operating system, where it updates results through Rich Infrastructure Services (RIS) communication.

- **SUT:** Polls iLO to check for requests from SUM, iLO Amplifier Pack, or HPE OneView for updates through local iLO using the iLO channel interface driver installed on the OS and orchestrates staging, deploying, and activating updates. You can adjust the polling interval by issuing the appropriate command-line option provided by SUT. Performs inventory on target servers, stages deployment, deploys updates, and then reboots the servers.
- **iLO 5 with integrated Smart Update** (Gen10 or later servers only): Performs iLO Repository-based updates by downloading the components from iLO Repository when iLO Installation Queue has the components which can be updated by SUT.
- **iLO Amplifier Pack and HPE OneView:** Displays available updates for servers. Communicates with SUT (or SUT 1.x) to initiate updates using the iLO Redfish interface. SUT reports the status of updates to iLO Amplifier Pack through iLO Restful Interface.
- **SUM:** A tool for firmware and driver maintenance for HPE ProLiant servers and associated options.



NOTE:

SUM and iLO Amplifier Pack should not manage the same nodes.

Updating firmware from the System Utilities

Use the Firmware Updates option to update firmware components in the system, including the system BIOS, NICs, and storage cards.

Procedure

1. Access the System ROM Flash Binary component for your server from the Hewlett Packard Enterprise Support Center.
2. Copy the binary file to a USB media or iLO virtual media.
3. Attach the media to the server.
4. Launch the System Utilities, and select Embedded Applications > Firmware Update.
5. Select a device.

The Firmware Updates screen lists details about your selected device, including the current firmware version in use.

6. Select Select Firmware File.
7. Select the flash file in the File Explorer list.

The firmware file is loaded and the Firmware Updates screen lists details of the file in the Selected firmware file field.

8. Select Image Description, and then select a firmware image.

A device can have multiple firmware images.

9. Select Start firmware update.

Updating the firmware from the UEFI Embedded Shell

Procedure

1. Access the System ROM Flash Binary component for your server from the Hewlett Packard Enterprise Support Center (<https://www.hpe.com/support/hpesc>).
2. Copy the binary file to a USB media or iLO virtual media.
3. Attach the media to the server.
4. Boot to the UEFI Embedded Shell.
5. To obtain the assigned file system volume for the USB key, enter `map -r`.
6. Change to the file system that contains the System ROM Flash Binary component for your server. Enter one of the `fsx` file systems available, such as `fs0:` or `fs1:`, and press **Enter**.
7. Use the `cd` command to change from the current directory to the directory that contains the binary file.
8. Flash the system ROM by entering `fwupdate -d BIOS -f filename`.
9. Reboot the server. A reboot is required after the firmware update in order for the updates to take effect and for hardware stability to be maintained.

Online Flash components

This component provides updated system firmware that can be installed directly on supported operating systems. Additionally, when used in conjunction with SUM, this Smart Component allows the user to update firmware on remote servers from a central location. This remote deployment capability eliminates the need for the user to be physically present at the server to perform a firmware update.

Drivers

i **IMPORTANT:** Always perform a backup before installing or updating device drivers.

Update drivers using any of the following **Smart Update Solutions**:

- Download the latest Service Pack for ProLiant (includes Smart Update Manager)
- Create a custom SPP download
- Download Smart Update Manager for Linux
- Download specific drivers

To locate the drivers for a server, go to the [Hewlett Packard Enterprise Support Center website](#), and then search for the product name/number.

Software and firmware

Update software and firmware before using the server for the first time, unless any installed software or components require an older version.

For system software and firmware updates, use one of the following sources:

- Download the SPP from the Hewlett Packard Enterprise website (<https://www.hpe.com/servers/spp/download>).
- Download individual drivers, firmware, or other system software components from the server product page in the Hewlett Packard Enterprise Support Center website (<https://www.hpe.com/support/hpesc>).

Operating system version support

For information about specific versions of a supported operating system, refer to the [operating system support matrix](#).

HPE Pointnext Portfolio

HPE Pointnext delivers confidence, reduces risk, and helps customers realize agility and stability. Hewlett Packard Enterprise helps customers succeed through Hybrid IT by simplifying and enriching the on-premise experience, informed by public cloud qualities and attributes.

Operational Support Services enable you to choose the right service level, length of coverage, and response time to fit your business needs. For more information, see the Hewlett Packard Enterprise website:

<https://www.hpe.com/us/en/services/operational.html>

Utilize the Advisory and Transformation Services in the following areas:

- Private or hybrid cloud computing
- Big data and mobility requirements
- Improving data center infrastructure
- Better use of server, storage, and networking technology

For more information, see the Hewlett Packard Enterprise website:

<https://www.hpe.com/services/consulting>



Proactive notifications

30 to 60 days in advance, Hewlett Packard Enterprise sends notifications to subscribed customers on upcoming:

- Hardware, firmware, and software changes
- Bulletins
- Patches
- Security alerts

You can subscribe to proactive notifications on the [Hewlett Packard Enterprise website](#).

NMI functionality

An NMI crash dump enables administrators to create crash dump files when a system is hung and not responding to traditional debugging methods.

An analysis of the crash dump log is an essential part of diagnosing reliability problems, such as hanging operating systems, device drivers, and applications. Many crashes freeze a system, and the only available action for administrators is to cycle the system power. Resetting the system erases any information that could support problem analysis, but the NMI feature preserves that information by performing a memory dump before a hard reset.

To force the OS to initiate the NMI handler and generate a crash dump log, the administrator can use the iLO Generate NMI feature.

Troubleshooting resources

Troubleshooting resources are available for HPE Gen10 and Gen10 Plus server products in the following documents:

- Troubleshooting Guide for HPE ProLiant Gen10 and Gen10 Plus servers provides procedures for resolving common problems and comprehensive courses of action for fault isolation and identification, issue resolution, and software maintenance.
- Error Message Guide for HPE ProLiant Gen10 Plus servers and HPE Synergy provides a list of error messages and information to assist with interpreting and resolving error messages.
- Integrated Management Log Messages and Troubleshooting Guide for HPE ProLiant Gen10 and Gen10 Plus servers and HPE Synergy provides IML messages and associated troubleshooting information to resolve critical and cautionary IML events.

To access troubleshooting resources for your product, see the [Hewlett Packard Enterprise website](#).

Battery replacement

If the server no longer automatically displays the correct date and time, you may need to replace the battery that provides power to the real-time clock.

WARNING: The computer contains an internal lithium manganese dioxide, a vanadium pentoxide, or an alkaline battery pack. A risk of fire and burns exists if the battery pack is not properly handled. To reduce the risk of personal injury:

- Do not attempt to recharge the battery.
 - Do not expose the battery to temperatures higher than 60°C (140°F).
 - Do not disassemble, crush, puncture, short external contacts, or dispose of in fire or water.
 - Replace only with the spare designated for this product.
-

To remove the component:

1. Power down the server.
2. Remove all power:
 - a. Disconnect each power cord from the power source.
 - b. Disconnect each power cord from the server.
3. Do one of the following:
 - Extend the server from the rack.
 - Remove the server from the rack.
4. Remove the access panel.
5. If installed, remove the secondary PCIe riser cage.
6. Locate the battery.
7. Remove the battery.

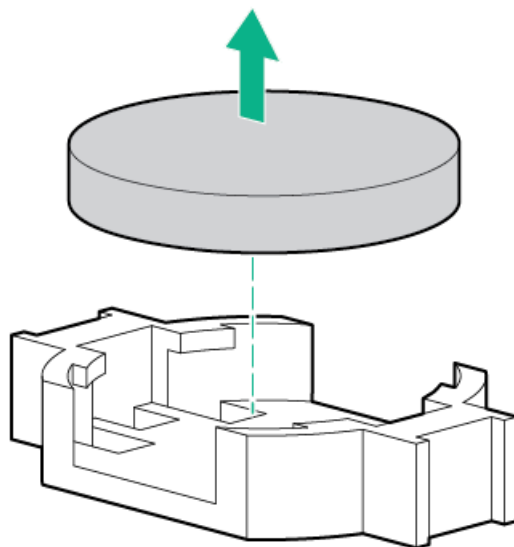

For more information about battery replacement or proper disposal, contact an authorized reseller or an authorized service provider.

Specifications

For more information on cable, power, environmental, compliance, and general specifications, see the [HPE Compute Transceiver and Cable Hardware Matrix](#).



Environmental specifications

Specification	Value
Temperature range ¹	—
Operating	10°C to 35°C (50°F to 95°F)
Nonoperating	-30°C to 60°C (-22°F to 140°F)
Relative humidity (noncondensing)	—
Operating	Minimum to be the higher (more moisture) of -12°C (10.4°F) dew point or 8% relative humidity Maximum to be 24°C (75.2°F) dew point or 90% relative humidity
Nonoperating	5% to 95% 38.7°C (101.7°F), maximum wet bulb temperature

¹ All temperature ratings shown are for sea level. An altitude derating of 1.0°C per 304.8 m (1.8°F per 1000 ft) to 3048 m (10,000 ft) is applicable. No direct sunlight allowed. Maximum rate of change is 20°C per hour (36°F per hour). The upper limit and rate of change might be limited by the type and number of options installed.

For certain approved hardware configurations, the supported system inlet temperature range is extended:

- 5°C to 10°C (41°F to 50°F) and 35°C to 40°C (95°F to 104°F) at sea level with an altitude derating of 1.0°C per every 175 m (1.8°F per every 574 ft) above 900 m (2953 ft) to a maximum of 3048 m (10,000 ft).
- 40°C to 45°C (104°F to 113°F) at sea level with an altitude derating of 1.0°C per every 125 m (1.8°F per every 410 ft) above 900 m (2953 ft) to a maximum of 3048 m (10,000 ft).

The approved hardware configurations for this system are listed on the [Hewlett Packard Enterprise website](#).

Mechanical specifications

Specification	Value
Height	8.75 cm (3.44 in)
Depth, SFF	71.2 cm (28.00 in)
Depth, LFF	74.9 cm (29.50 in)
Width	44.54 cm (17.54 in)
Weight, SFF minimum	16.12 kg (35.54 lbs)
Weight, SFF maximum	28.77 kg (63.43 lbs)
Weight, LFF minimum	22.48 kg (49.56 lbs)
Weight, LFF maximum	33.99 kg (74.94 lbs)

Power supply specifications

Depending on the installed options and the regional location where the server was purchased, the server can be configured with one of the following power supplies:

- [HPE 800 W Flex Slot Universal Hot-plug Low Halogen Power Supply](#)
- [HPE 800 W Flex Slot Platinum Hot-plug Low Halogen Power Supply](#)
- [HPE 800 W Flex Slot Titanium Hot-plug Low Halogen Power Supply](#)
- [HPE 800 W Flex Slot -48 VDC Hot-plug Low Halogen Power Supply](#)
- [HPE 1600 W Flex Slot Platinum Hot-plug Low Halogen Power Supply](#)
- [HPE 1600 W Flex Slot -48 VDC Hot-plug Power Supply](#)

For detailed power supply specifications, see the QuickSpecs on the [Hewlett Packard Enterprise website](#).



HPE 800 W Flex Slot Universal Hot-plug Low Halogen Power Supply

Specification	Value
Input requirements	—
Rated input voltage	200 VAC to 277 VAC 380 VDC
Rated input frequency	50 Hz to 60 Hz
Rated input current	4.4 A at 200 VAC 3.8 A at 230 VAC 2.3 A at 380 VDC
Maximum rated input power	869 W at 200 VAC 865 W at 230 VAC 861 W at 277 VAC 863 W at 380 VDC
BTUs per hour	2964 at 200 VAC 2951 at 230 VAC 2936 at 277 VAC 2943 at 380 VDC
Power supply output	—
Rated steady-state power	800 W at 200 VAC to 277 VAC input
Maximum peak power	800 W at 200 VAC to 277 VAC input

HPE 800 W Flex Slot Platinum Hot-plug Low Halogen Power Supply

Specification	Value
Input requirements	—
Rated input voltage	100 VAC to 127 VAC 200 VAC to 240 VAC 240 VDC for China only
Rated input frequency	50 Hz to 60 Hz Not applicable to 240 VDC
Rated input current	9.1 A at 100 VAC 4.4 A at 200 VAC 3.6 A at 240 VDC for China only
Maximum rated input power	899 W at 100 VAC 867 W at 200 VAC 864 W at 240 VDC for China only
BTUs per hour	3067 at 100 VAC 2958 at 200 VAC 2949 at 240 VAC for China only
Power supply output	—
Rated steady-state power	800 W at 100 VAC to 127 VAC input 800 W at 100 VAC to 240 VAC input 800 W at 240 VDC input for China only
Maximum peak power	800 W at 100 VAC to 127 VAC input 800 W at 100 VAC to 240 VAC input 800 W at 240 VDC input for China only

HPE 800 W Flex Slot Titanium Hot-plug Low Halogen Power Supply

Specification	Value
Input requirements	—
Rated input voltage	200 VAC to 240 VAC 240 VDC for China only
Rated input frequency	50 Hz to 60 Hz Not applicable to 240 VDC
Rated input current	4.3 A at 200 VAC 3.6 A at 240 VAC 3.6 A at 240 VDC for China only
Maximum rated input power	851 W at 200 VAC 848 W at 240 VAC 848 W at 240 VDC for China only
BTUs per hour	2905 at 200 VAC 2893 at 240 VAC 2893 at 240 VDC for China only
Power supply output	—
Rated steady-state power	800 W at 200 VAC to 240 VAC input 800 W at 240 VDC input for China only
Maximum peak power	800 W at 200 VAC to 240 VAC input 800 W at 240 VDC input for China only

HPE 800 W Flex Slot -48 VDC Hot-plug Low Halogen Power Supply

Specification	Value
Input requirements	—
Rated input voltage	-40 VDC to -72 VDC -48 VDC nominal input
Rated input current	22.1 A at -40 VDC input 18.2 A at -48 VDC input, nominal input 12.0 A at -72 VDC input
Rated input power (W)	874 W at -40 VDC input 865 W at -48 VDC input, nominal input 854 W at -72 VDC input
Rated input power (BTUs per hour)	2983 at -40 VDC input 2951 at -48 VDC input, nominal input 2912 at -72 VDC input
Power supply output	—
Rated steady-state power (W)	800 W at -40 VDC to -72 VDC
Maximum peak power (W)	800 W at -40 VDC to -72 VDC
Maximum peak power	800 W at -40 VDC to -72 VDC input

WARNING: To reduce the risk of electric shock or energy hazards:

- This equipment must be installed by trained service personnel.
- Connect the equipment to a reliably grounded secondary circuit source. A secondary circuit has no direct connection to a primary circuit and derives its power from a transformer, converter, or equivalent isolation device.
- The branch circuit overcurrent protection must be rated 27 A.

CAUTION: This equipment is designed to permit the connection of the earthed conductor of the DC supply circuit to the earthing conductor at the equipment.

If this connection is made, all of the following must be met:

- This equipment must be connected directly to the DC supply system earthing electrode conductor or to a bonding jumper from an earthing terminal bar or bus to which the DC supply system earthing electrode conductor is connected.
- This equipment must be located in the same immediate area (such as adjacent cabinets) as any other equipment that has a connection between the earthed conductor of the same DC supply circuit and the earthing conductor, and also the point of earthing of the DC system. The DC system must be earthed elsewhere.
- The DC supply source is to be located within the same premises as the equipment.
- Switching or disconnecting devices must not be in the earthed circuit conductor between the DC source and the point of connection of the earthing electrode conductor.

HPE 1600 W Flex Slot Platinum Hot-plug Low Halogen Power Supply

Specification	Value
Input requirements	—
Rated input voltage	200 VAC to 240 VAC 240 VDC for China only
Rated input frequency	50 Hz to 60 Hz
Rated input current	8.7 A at 200 VAC 7.5 A at 230 VAC
Maximum rated input power	1734 W at 200 VAC 1727 W at 230 VAC
BTUs per hour	5918 at 200 VAC 5891 at 230 VAC
Power supply output	—
Rated steady-state power	1600 W at 200 VAC to 240 VAC input 1600 W at 240 VDC input
Maximum peak power	2200 W for 1 ms (turbo mode) at 200 VAC to 240 VAC input

HPE 1600 W Flex Slot -48 VDC Hot-plug Power Supply

Specification	Value
Input requirements	—
Rated input voltage	-40 VDC to -72 VDC
Rated input frequency	DC
Nominal input current	44.2 A DC at -40 VDC input 36.6 A DC at -48 VDC input 24.4 A DC at -72 VDC input
Maximum Rated Input Wattage Rating	1766 W at -40 VDC input 1758 W at -48 VDC input 1755 W at -72 VDC input
BTUs per hour	6026 at -40 VDC input 6000 at -48 VDC input input 5989 at -72 VDC input
Power supply output	—
Rated steady-state power	1600 W at -40 VDC to -72 VDC
Maximum peak power	1600 W at -40 VDC to -72 VDC



Accessing Hewlett Packard Enterprise Support

- For live assistance, go to the Contact Hewlett Packard Enterprise Worldwide website:

<https://www.hpe.com/info/assistance>

- To access documentation and support services, go to the Hewlett Packard Enterprise Support Center website:

<https://www.hpe.com/support/hpesc>

Information to collect

- Technical support registration number (if applicable)
- Product name, model or version, and serial number
- Operating system name and version
- Firmware version
- Error messages
- Product-specific reports and logs
- Add-on products or components
- Third-party products or components



Accessing updates

- Some software products provide a mechanism for accessing software updates through the product interface. Review your product documentation to identify the recommended software update method.

- To download product updates:

Hewlett Packard Enterprise Support Center

<https://www.hpe.com/support/hpesc>

Hewlett Packard Enterprise Support Center: Software downloads

<https://www.hpe.com/support/downloads>

My HPE Software Center

<https://www.hpe.com/software/hpesoftwarecenter>

- To subscribe to eNewsletters and alerts:

<https://www.hpe.com/support/e-updates>

- To view and update your entitlements, and to link your contracts and warranties with your profile, go to the Hewlett Packard Enterprise Support Center More Information on Access to Support Materials page:

<https://www.hpe.com/support/AccessToSupportMaterials>

ⓘ IMPORTANT:

Access to some updates might require product entitlement when accessed through the Hewlett Packard Enterprise Support Center. You must have an HPE Passport set up with relevant entitlements.

Remote support

Remote support is available with supported devices as part of your warranty or contractual support agreement. It provides intelligent event diagnosis, and automatic, secure submission of hardware event notifications to Hewlett Packard Enterprise, which initiates a fast and accurate resolution based on the service level of your product. Hewlett Packard Enterprise strongly recommends that you register your device for remote support.

If your product includes additional remote support details, use search to locate that information.

HPE Get Connected

<https://www.hpe.com/services/getconnected>

HPE Pointnext Tech Care

<https://www.hpe.com/services/techcare>

HPE Datacenter Care

<https://www.hpe.com/services/datacentercare>

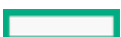

Warranty information

To view the warranty information for your product, see the links provided below:

HPE ProLiant and IA-32 Servers and Options

<https://www.hpe.com/support/ProLiantServers-Warranties>

HPE Enterprise and Cloudline Servers

<https://www.hpe.com/support/EnterpriseServers-Warranties>

HPE Storage Products

<https://www.hpe.com/support/Storage-Warranties>

HPE Networking Products

<https://www.hpe.com/support/Networking-Warranties>



Regulatory information

To view the regulatory information for your product, view the Safety and Compliance Information for Server, Storage, Power, Networking, and Rack Products, available at the Hewlett Packard Enterprise Support Center:

<https://www.hpe.com/support/Safety-Compliance-EnterpriseProducts>

Additional regulatory information

Hewlett Packard Enterprise is committed to providing our customers with information about the chemical substances in our products as needed to comply with legal requirements such as REACH (Regulation EC No 1907/2006 of the European Parliament and the Council). A chemical information report for this product can be found at:

<https://www.hpe.com/info/reach>

For Hewlett Packard Enterprise product environmental and safety information and compliance data, including RoHS and REACH, see:

<https://www.hpe.com/info/ecodata>

For Hewlett Packard Enterprise environmental information, including company programs, product recycling, and energy efficiency, see:

<https://www.hpe.com/info/environment>

Documentation feedback

Hewlett Packard Enterprise is committed to providing documentation that meets your needs. To help us improve the documentation, use the Feedback button and icons (located at the bottom of an opened document) on the Hewlett Packard Enterprise Support Center portal (<https://support.hpe.com/hpesc>) to send any errors, suggestions, or comments. All document information is captured by the process.

