

VDO Atomic Dot

User Guide

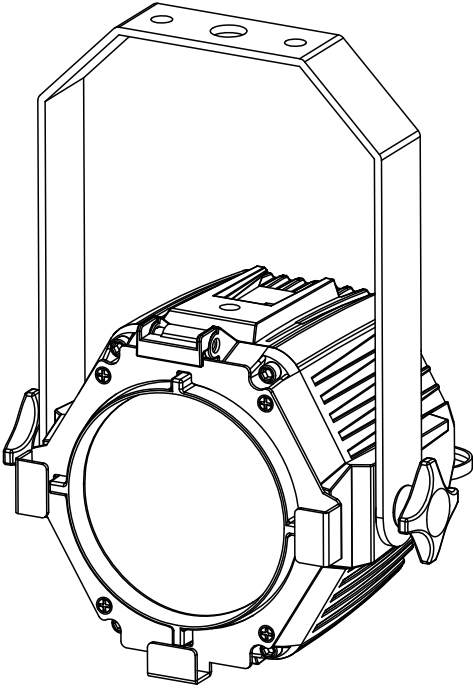
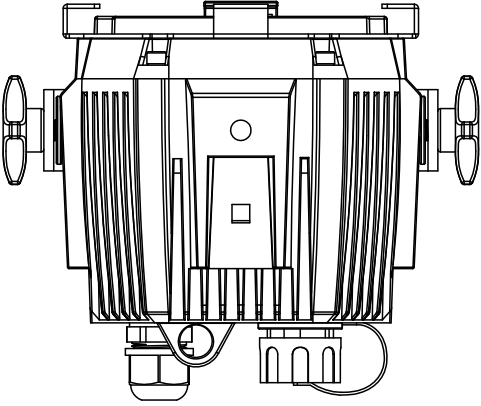
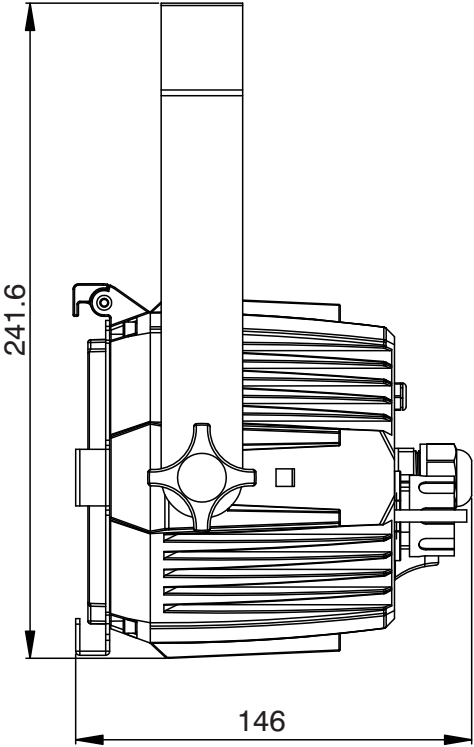
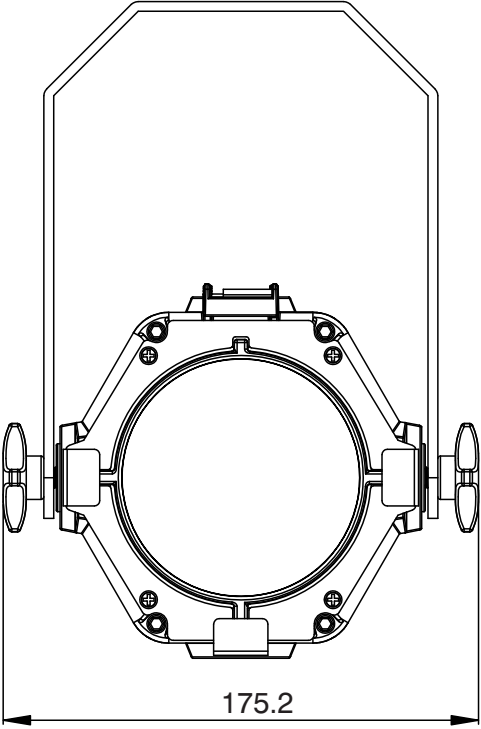

Table of contents

Dimensions	3
Safety information	8
Précautions d'emploi.....	10
Sicherheitshinweise	13
Introduction	17
Before using the product for the first time.....	17
Fixture overview.....	18
Physical installation.....	19
Fixture location.....	19
Ways of mounting the fixture.....	19
Mounting the fixture on a truss using the hanging bracket	20
Mounting 2 or 4 fixtures on a truss using the double width hanging bracket	21
Mounting the fixture on a truss using direct clamp	22
Interlocking multiple fixtures	23
Installing optical accessories.....	25
Safety bonds	26
AC power and data connection.....	27
Safety limits for connecting devices	27
AC power connection to Junction Box or Break-In cable.....	27
Data connection to Junction Box or Break-In cable.....	28
PDE connections between fixtures.....	30
System Setup.....	31
Setting options by RDM.....	31
Scanning for RDM devices on the data link.....	31
Getting status and setting options by RDM	31
Martin Companion and RDM.....	31
RDM.....	32
Using the VDO Atomic Dot	34
Thermal regulation	34
Video display using P3.....	34
DMX control	34
LED PWM frequency control	34
Status LED	35
Pushbutton functions.....	35
Maintenance	37
Cleaning	37
LED performance	37
Installing new software.....	37
DMX protocol	38
DMX mode 1 channel.....	38
DMX mode 3 channel.....	38
DMX mode 4 channel.....	39
DMX mode Basic	39
DMX mode Extended	42
FX Table.....	49
Troubleshooting	52

Dimensions

Fixture dimensions



All dimensions are given in millimeters.

Coupler (for interlocking two fixtures)

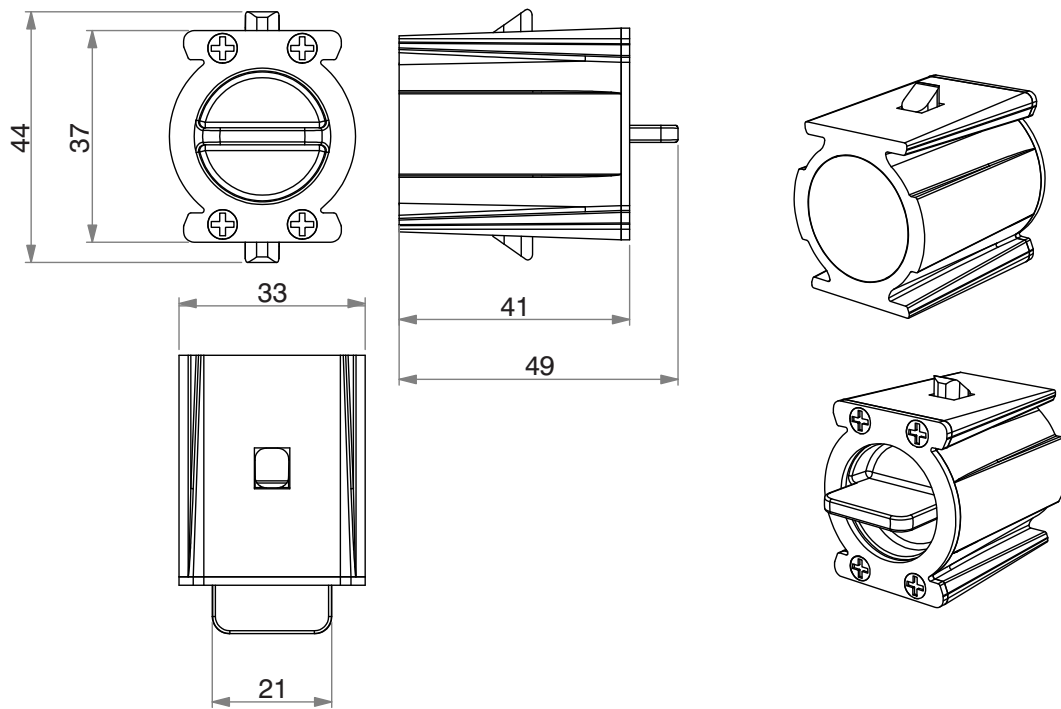

Half Coupler (for attaching to truss)

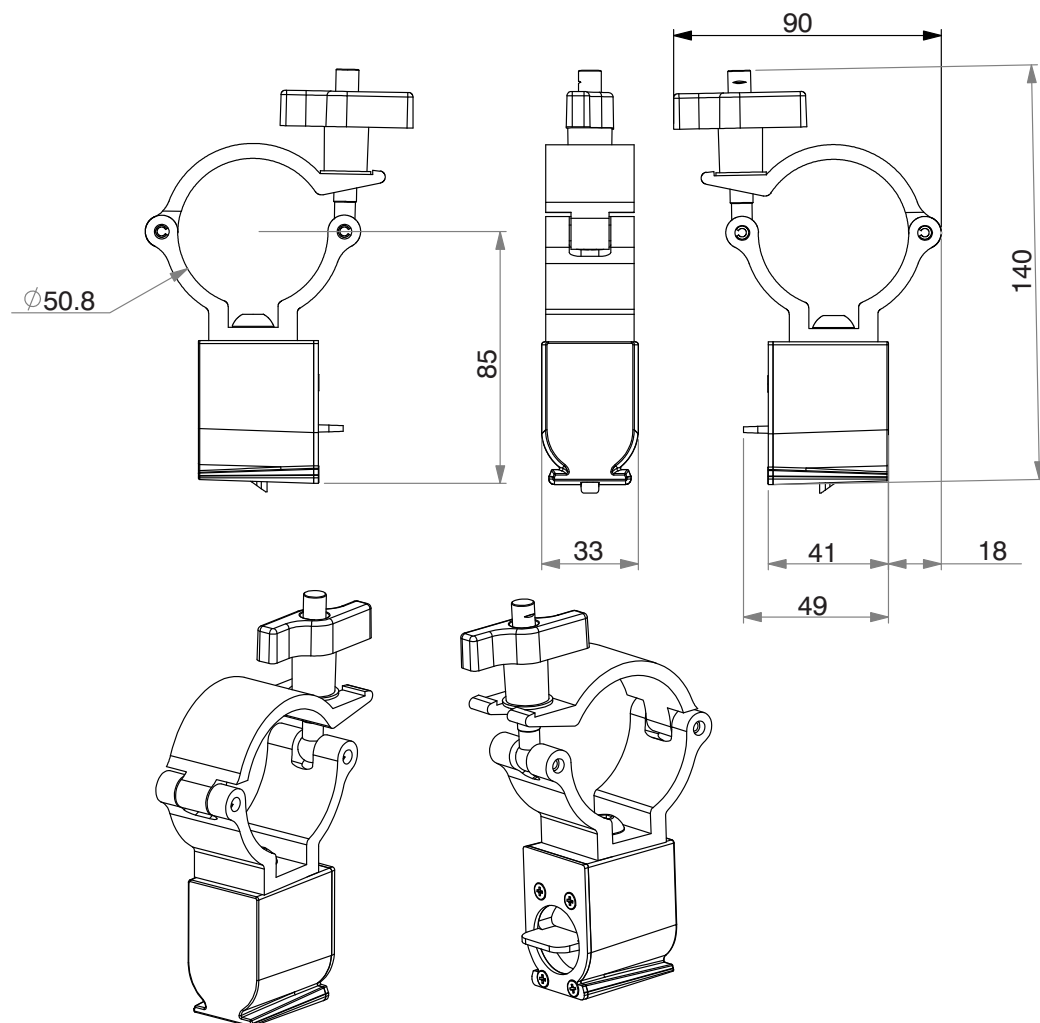

All dimensions are given in millimeters.

Interlock Adapter (for attaching to microphone stand)

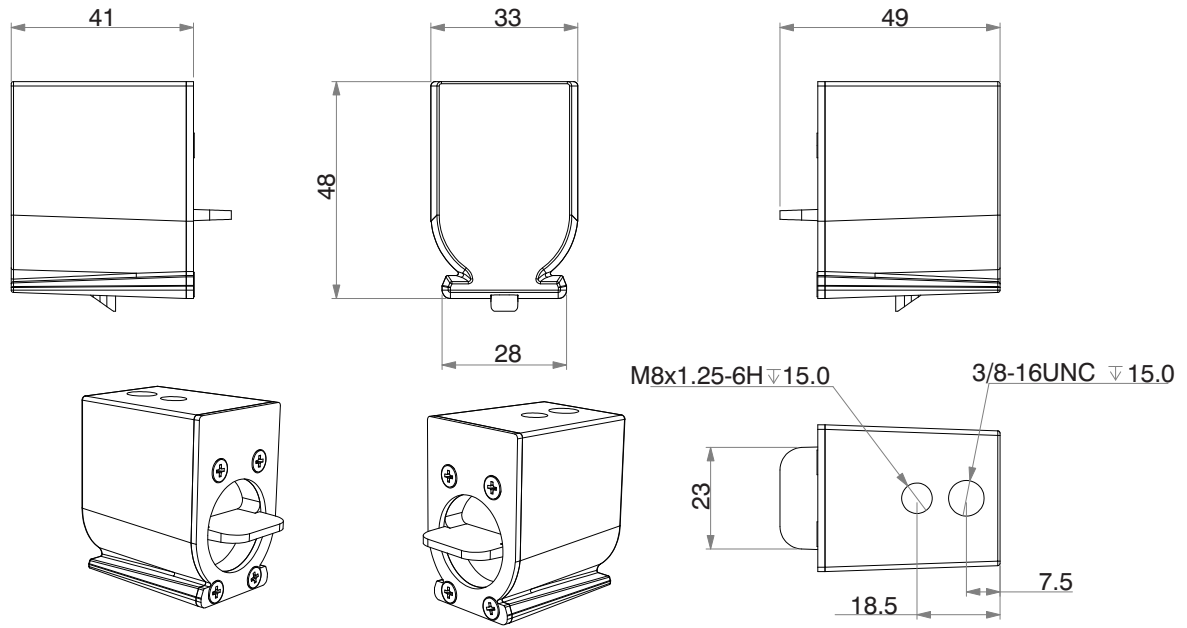

Pivot coupler (for interlocking two fixtures at an angle)

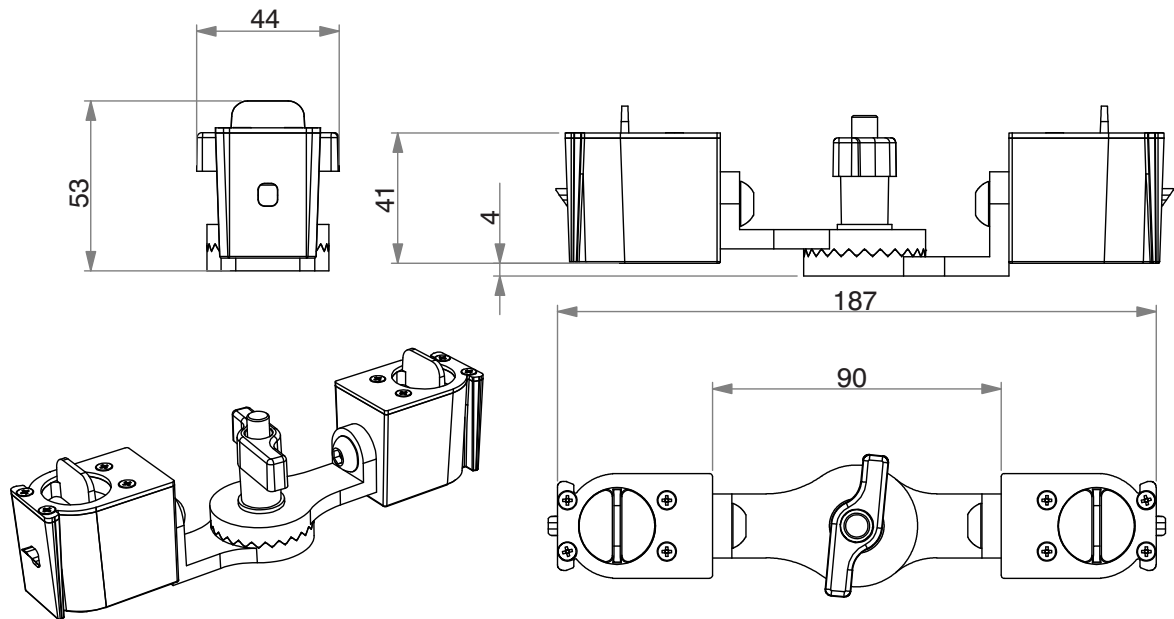

Double Width Bracket (for creating 2-lite and 4-lite fixtures)

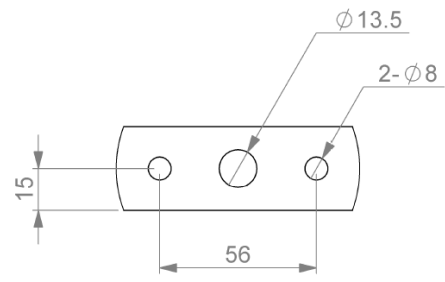

DETAIL A
SCALE 1 : 2

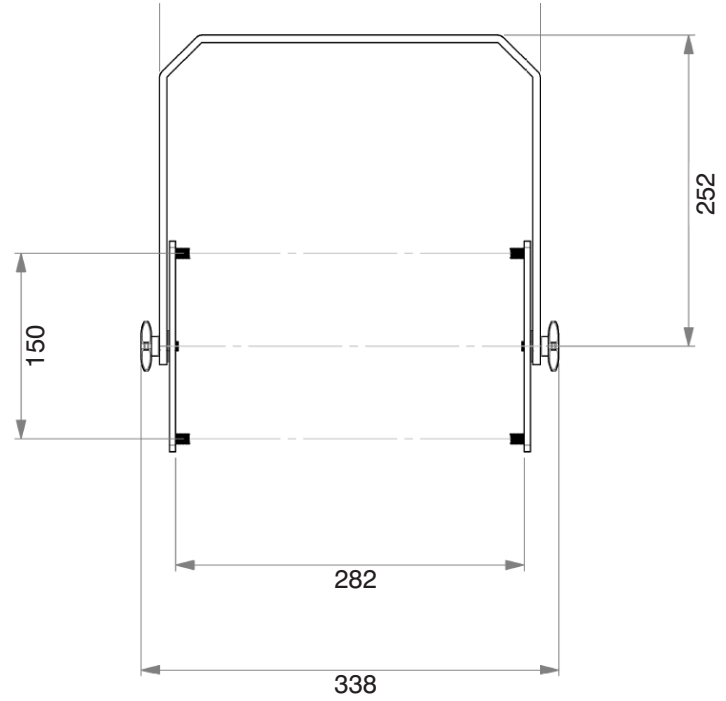
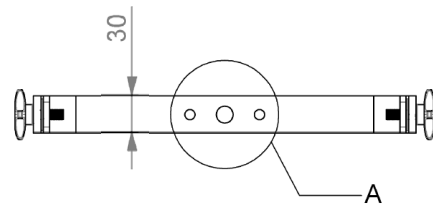
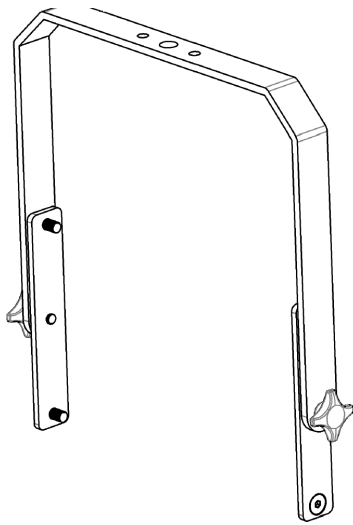

All dimensions are given in millimeters.

Spigot Adapter (for mounting on standard spigot accessories)

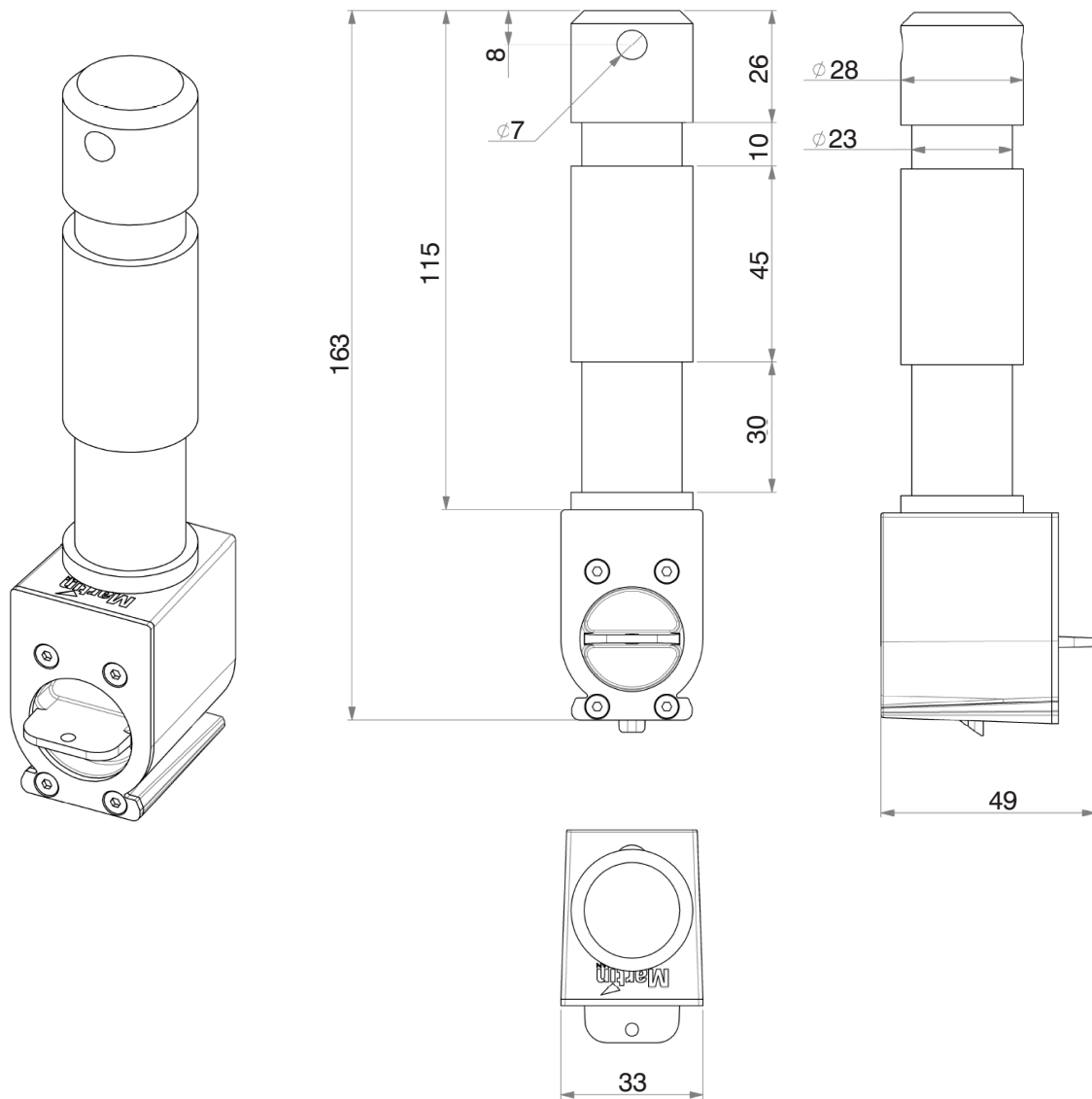

All dimensions are given in millimeters.

© 2012-2023 HARMAN PROFESSIONAL DENMARK ApS. All rights reserved. Features, specifications and appearance are subject to change without notice. HARMAN PROFESSIONAL DENMARK ApS and all affiliated companies disclaim liability for any injury, damage, direct or indirect loss, consequential or economic loss or any other loss occasioned by the use of, inability to use or reliance on the information contained in this document. Martin is a registered trademark of HARMAN PROFESSIONAL DENMARK ApS registered in the United States and/or other countries.

HARMAN PROFESSIONAL DENMARK ApS • Olof Palmes Alle 44 • 8200 Aarhus N • Denmark
HARMAN PROFESSIONAL SOLUTIONS U.S. • 8500 Balboa Blvd. • Northridge • CA 91329 • USA

www.martin.com

VDO Atomic Dot User Guide Revision D

Safety information



WARNING!

Read the safety precautions in this manual before installing, operating or servicing this product.

The following symbols are used to identify important safety information on the product and in this manual:



Warning!

Safety hazard. Risk of severe injury or death.



Warning!

Powerful light emission. Risk of eye injury.



Warning!

See user manual for important safety information.



Warning!

Hazardous voltage. Risk of lethal or severe electric shock.



Warning!

Fire hazard.



Warning!

Hot surfaces.



VDO Atomic Dot CLD only: Warning! Risk Group 2 product according to EN 62471 and IEC/TR 62778. Possibly hazardous radiation emitted from this product. May be harmful to the eyes. Do not stare at operating lamp and do not view the light output with optical instruments or any device that may concentrate the beam.

This lighting fixture is for professional use only and must be installed by a qualified technician. It is not for household use. It presents risks of severe injury or death due to fire hazards, electric shock and falls. It can create a fire hazard or a risk of eye injury if the safety precautions below are not followed.



Install, operate and service Martin® products only as directed in their user manuals, or you may create a safety hazard or cause damage that is not covered by product warranties. Follow the safety precautions listed below and observe all warnings in this manual and printed on the product. Keep this user manual for future use.

For the latest user documentation and other information about this and all Martin® products, please visit the Martin® website at <http://www.martin.com>

If you have any questions about how to install, operate or service the fixture safely, please contact your Martin® distributor (see www.martin.com/distributors for details) or in the USA on 1-844-776-4899.

Respect all locally applicable laws, codes and regulations when installing, operating or servicing the fixture.



Protection from electric shock

Ensure that the fixture is electrically connected to ground (earth).

Disconnect the fixture from AC power when not in use.

Do not open the fixture or remove any cover. Refer any service operation not described in this manual to an authorized Martin Service partner.

Shut down power to the entire installation at the main power distribution board and lock out power before carrying out any installation or maintenance work.

Use only a source of AC power that complies with local building and electrical codes and has both overload and ground-fault (earth-fault) protection.

Isolate the fixture from power immediately if any seal, cover, cable, or other component is damaged, defective, deformed or showing signs of overheating. Do not reapply power until repairs have been completed

Before using the fixture, check that all power distribution equipment and cables are in perfect condition and are of suitable type for the location (including water, pollution, temperature and UV resistance).

Do not immerse the fixture in water or any other fluid, or install it in a location where flooding may occur.

The light source contained in this luminaire shall only be replaced by the manufacturer or their service agent or a similar qualified person.

When connecting multiple fixtures in a daisy chain, observe the safety limits in section "Safety limits for connecting devices" on page 27.



Protection from burns and fire

Do not operate the fixture if the ambient temperature (T_a) exceeds 40°C (104°F).

The surface of the fixture can reach up to 55°C (131°F) if the fixture is operated at the maximum permitted ambient temperature. Allow the fixture to cool for at least 5 minutes before handling.



Install the fixture on a non-combustible surface (brick, concrete, plaster etc.) only.

Do not aim the fixture towards combustible materials (fabric, wood, paper etc.) that are within 50 cm (19 in.) of the fixture.

Keep the fixture well away from flammable materials (volatile liquids etc.).

Ensure that there is free and unobstructed airflow around the fixture.

Allow at least 0.1 m (4 in.) free space around the fixture.

Do not attempt to bypass thermostatic switches or fuses.

Do not modify the fixture in any way not described in this manual or install other than genuine Martin® parts. Do not stick filters, masks or other materials onto any lens or other optical component. Use only accessories approved by Martin® to modify the light beam.



Protection from eye injury

VDO Atomic Dot CLD only: Warning! Risk Group 2 product according to EN 62471 and IEC/TR 62778.

Do not look directly into the product's light output.

Do not look at operating lamp. Eye injury may result.

Do not look at the light output with magnifiers, telescopes, binoculars or similar optical instruments that may concentrate the light output.

Ensure that persons are not looking directly into the front of the fixture when the product lights up suddenly. This can happen when power is applied, when the product receives a DMX signal, or when certain control menu items are selected.

To minimize the risk of eye irritation or injury, disconnect the fixture from power at all times when the fixture is not in use and provide well-lit conditions to reduce the pupil diameter of anyone working on or near the fixture.

The VDO Atomic Dot CLD fixture fixtures fall into the following risk groups according to EN 62471 and IEC/TR 62778 at the distances indicated below.

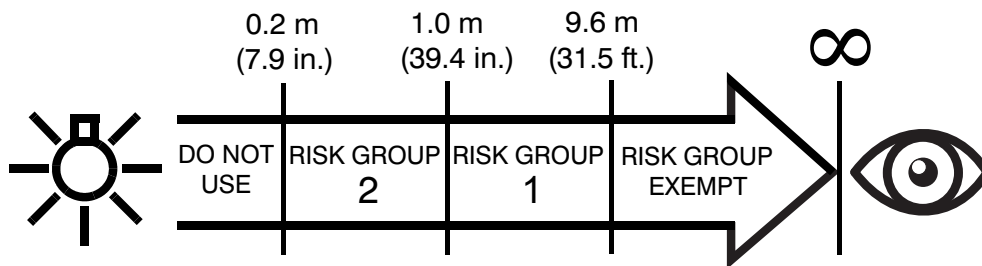

The luminaire should be positioned so that prolonged staring into the luminaire at a distance closer than 1 m is not expected.



Protection from injury

Fasten the fixture securely to a fixed surface or structure when in use. The fixture is not portable when installed.

Ensure that all supporting structures, surfaces, fasteners and lifting equipment can bear the weight of all the devices they are intended to support plus an adequate safety margin, and that they conform to local building and safety regulations.

Ensure that any accessory such as gel frames, gobo holders are securely fastened.

Block access below the work area and work from a stable platform whenever installing, setting, adjusting, or cleaning the fixture.

Do not operate the fixture with missing or damaged covers, shields or any optical component.

If an operating problem occurs, stop using the fixture immediately and disconnect it from power. Do not attempt to use a fixture that is obviously damaged.

Précautions d'emploi



ATTENTION !

Lisez les précautions d'emploi listées dans ce manuel avant d'installer, d'utiliser ou de faire la maintenance de l'appareil.

Les symboles ci-dessous sont utilisés pour identifier les informations de sécurité importantes:



Attention !
Risque important. Risque de blessure sévère voire mortelle.



Attention !
Emission puissante de lumière. Risque de lésion oculaire.



Attention !
Reportez-vous au manuel d'utilisation pour les informations de sécurité.



Attention !
Tensions dangereuses. Risque de blessure sévère voire mortelle par électrisation.



Attention !
Risque d'incendie.



Attention !
Surfaces chaudes.



VDO Atomic Dot CLD seulement: Attention ! Groupe de risques 2 selon EN 62471 et IEC/TR 62778. Cet appareil émet des radiations potentiellement dangereuses. Ne fixez pas le regard sur la source de lumière allumée et ne regardez pas dans le faisceau avec un instrument optique ou tout appareil qui pourrait concentrer la lumière.

Ce luminaire est réservé à un usage professionnel et doit être installé par un technicien qualifié uniquement. Il présente des risques de blessures sévères voire mortelles par brûlure ou incendie, électrisation et chute. Il peut créer un risque important d'incendie ou de lésions oculaires si les précautions d'emploi ci-dessous ne sont pas respectées.



Veillez uniquement installer, utiliser ou réaliser la maintenance des produits Martin® en respectant les directives de leur manuel d'utilisation au risque de créer un risque pour la sécurité ou de causer des dommages qui ne seraient pas couverts par la garantie du produit. Suivez les précautions d'emploi listées cidessous et respectez toutes les mises en garde continues dans ce manuel et imprimées sur le produit. Gardez ce mode d'emploi pour un usage ultérieur.

Pour obtenir les dernières mises à jour de ce document ou de toute information sur ce produit et le reste de la gamme Martin®, consultez le site web de Martin® : <http://www.martin.com>

Pour toute question sur l'installation, l'utilisation ou l'entretien de cet appareil en toute sécurité, contactez votre distributeur Martin® (voir www.martin.com/distributors pour plus de détail) ou bien, pour les USA, appelez le 1-844-776-4899.

Respectez toutes les réglementations, codes et lois locales applicables lors de l'installation, de l'utilisation et de la maintenance de cet appareil.



Protection contre les risques électriques

Assurez-vous que l'appareil est correctement relié à la terre électrique. Déconnectez l'appareil du secteur lorsqu'il n'est pas en service. N'ouvrez pas l'appareil et ne déposez aucun capot. Référez toute opération non décrite ici à un service technique agréé par Martin.

Coupez l'alimentation de l'installation au tableau de distribution et consignez-la avant de commencer l'installation ou la maintenance.

N'utilisez qu'une source d'alimentation AC compatible avec les codes locaux de la construction et de l'électricité et protégée contre les surintensités et les défauts différentiels.

Isolez immédiatement l'appareil du secteur si un joint, un capot, un câble ou tout autre composant est endommagé, défectueux, déformé ou montre des signes de surchauffe. Ne remettez pas le système sous tension tant que les réparations n'ont pas été effectuées.

Avant d'utiliser l'appareil, vérifiez que tous les équipements de distribution d'énergie et tous les câbles sont en parfaite condition et sont adaptés au lieu d'installation (incluant humidité, pollution, température et résistance aux UV).

N'immergez pas l'appareil dans l'eau ou dans tout autre fluide. Ne l'installez pas dans une zone inondable.

La source de lumière de cet appareil ne peut être remplacée que par le fabricant ou ses services techniques ou un technicien qualifié.

Lorsque vous connectez plusieurs appareils en cascade, respectez les limitations indiquées dans la section "Limites de sécurité pour la connexion des appareils" en page 27.



Protection contre les incendies et les brûlures

N'utilisez pas l'appareil si la température ambiante (T_a) dépasse 40°C (104°F).

La surface de l'appareil peut atteindre 55°C (131°F) si l'appareil est utilisé à la température ambiante maximale permise. Laissez l'appareil refroidir au moins 5 minutes avant de le manipuler.



Installez l'appareil sur une surface non combustible (brique, béton, plâtre etc.) uniquement.

Ne braquez pas l'appareil vers des matériaux combustibles (papier, bois, tissu etc.) s'ils sont situés à moins de 50 cm (19 in.) de l'appareil.

Maintenez l'appareil éloigné de tout matériau inflammable (liquides volatiles etc.).

Assurez-vous que l'air circule librement autour de l'appareil.

Laissez au moins 0,1 m (4 in.) d'espace libre autour de l'appareil.

N'essayez pas de contourner l'action des organes de protection tels que fusibles ou interrupteurs thermostatiques.

Ne modifiez pas l'appareil autrement que selon les directives contenues dans ce manuel et n'installez que des pièces détachées d'origine Martin®. Ne collez pas de filtre, de masque ou tout autre matériau sur les lentilles et les composants optiques. Utilisez uniquement des accessoires homologués par Martin® pour modifier le faisceau de l'appareil.



Protection contre les lésions oculaires

VDO Atomic Dot CLD seulement: Attention ! Groupe de risques 2 selon EN 62471 et IEC/TR 62778.

Ne regardez pas directement dans le faisceau de l'appareil.

Ne regardez pas la source de lumière lorsqu'elle est allumée. Risque de lésion oculaire.

Ne regardez pas la lumière produite par l'appareil avec un instrument optique qui pourrait concentrer la lumière tel qu'une loupe, un microscope, un télescope etc.

Assurez-vous que personne ne regarde l'appareil lorsqu'il s'allume brusquement. Ceci peut se produire à la mise sous tension, à réception d'un signal DMX ou lors de la manipulation de certaines rubriques du panneau de contrôle.

Pour minimiser le risque d'irritation de l'oeil ou de lésions oculaires, déconnectez toujours le produit du secteur lorsqu'il n'est pas utilisé et maintenez un éclairage minimal suffisant pour réduire le diamètre des pupilles de toute personne travaillant à proximité ou sur l'appareil lui-même.

Le VDO Atomic Dot CLD tombe dans les groupes de risque ci-dessous selon EN 62471 et IEC/TR 62778 en fonction de sa distance à l'observateur.

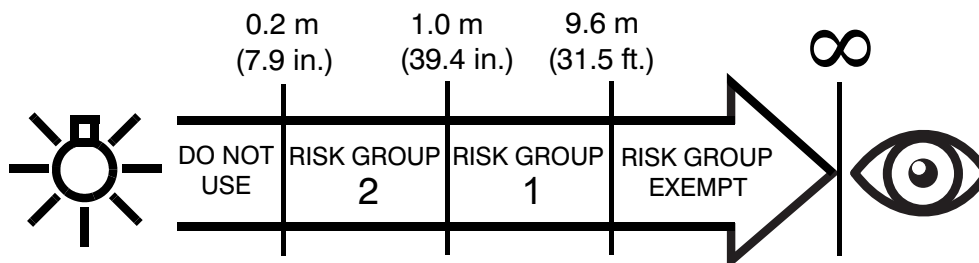

L'appareil doit être installé de façon à éviter toute observation prolongée à une distance inférieure à 1 m.



Protection contre les blessures

Fixez l'appareil fermement à une surface fixe lors de son utilisation. L'appareil n'est pas transportable pendant son fonctionnement.

Assurez-vous que toutes les structures et surfaces porteuses et que tous les accessoires de fixation et de levage supportent le poids de tous les appareils qu'ils reçoivent avec une conséquente marge de sécurité et qu'ils sont conformes aux codes et aux règles de sécurité locales et de la construction.

Assurez-vous que tous les accessoires tels que porte-filtres, porte-gobos ... sont fermement fixés.

Interdisez l'accès sous la zone de travail et travaillez sur une plateforme stable lors de l'installation, des réglages, du paramétrage ou du nettoyage de l'appareil.

N'utilisez pas l'appareil s'il manque des capots, des protections ou des composants optiques ou s'ils sont endommagés.

En cas de problème de fonctionnement, arrêtez immédiatement l'appareil et déconnectez-le du secteur. N'essayez pas d'utiliser un appareil visiblement endommagé.

Sicherheitshinweise



WARNUNG!

Lesen Sie die Sicherheitshinweise, bevor Sie das Produkt installieren, in Betrieb nehmen, verwenden oder reparieren.

Die folgenden Warnhinweise werden in dieser Anleitung und auf dem Produkt verwendet:



Warnung!

Sicherheitsrisiko. Verletzungs- oder Lebensgefahr



Warnung!

Austritt von Licht hoher Intensität. Gefahr der Augenverletzung.



Warnung!

Wichtiger Sicherheitshinweis. Bedienungsanleitung beachten.



Warnung!

Hochspannung. Verletzungs- oder Lebensgefahr.



Warnung!

Feuergefahr.



Warnung!

Heiße Oberfläche. Verbrennungsgefahr. Nicht berühren.



Nur VDO Atomic Dot CLD: **Warnung!** Produkt der Risikogruppe 2 gemäß EN 62471 und IEC/TR 62778. Das Gerät erzeugt möglicherweise schädliche Strahlung. Kann die Augen schädigen. Blicken Sie nicht direkt oder mit sammelnden optischen Instrumenten oder Geräten, die den Lichtstrahl verstärken, in den Lichtstrahl.

Dieses Gerät ist nur für den professionellen Einsatz zugelassen. Es muss von einem qualifizierten Techniker installiert werden. Die Verwendung in privaten Haushalten ist unzulässig. Von diesem Produkt gehen erhebliche Verletzungsgefahren und Lebensgefahr durch Feuer und Verbrennung, elektrischen Schlag und Absturz aus, wenn die in dieser Anleitung gegebenen Sicherheitshinweise nicht befolgt werden.



Installieren, verwenden und warten Sie Produkte und Zubehör von Martin® nur, wie in der jeweiligen Anleitung vorgeschrieben. Andernfalls erzeugen Sie ein Sicherheitsrisiko oder verursachen Schäden, die von der Gewährleistung ausgeschlossen sind.

Befolgen Sie die Sicherheitshinweise und beachten Sie alle in dieser Anleitung, in der Bedienungsanleitung oder auf dem Produkt gegebenen Warnungen. Bewahren Sie diese Anleitung auf.

Die neueste Anleitung und andere Dokumente für alle Produkte von Martin® finden Sie zum Download auf der Webseite www.martin.com.

Wenn Sie Fragen zur sicheren Installation und zum sicheren Betrieb dieses Produkts haben, wenden Sie sich bitte an den technischen Support von Harman Professional:

- Nordamerika: HProTechSupportUSA@harman.com, Telefon: (844) 776-4899
- Rest der Welt: Bitte wenden Sie sich an Ihren nationalen Vertrieb.

Beachten Sie alle allgemeinen und lokalen Gesetze, Normen und Vorschriften, wenn Sie das Gerät installieren, in Betrieb nehmen, verwenden oder reparieren.



Schutz vor elektrischem Schlag

Erden Sie das Gerät immer elektrisch.

Trennen Sie das Gerät allpolig von der Stromquelle, wenn es nicht in Gebrauch ist.

Öffnen Sie das Gerät nicht. Entfernen Sie keine Abdeckungen. Überlassen Sie alle Wartungsarbeiten, die nicht in dieser Anleitung beschrieben werden, einem autorisiertem Martin Servicepartner.

Trennen Sie die gesamte Installation vom Netz und sichern Sie gegen Wiedereinschalten, bevor Sie Installations- oder Wartungsarbeiten ausführen.

Verwenden Sie nur eine Wechselstromquelle, die den allgemeinen und lokalen Sicherheitsvorschriften entspricht. Die Stromquelle muss mit einer Überlastsicherung und einem Fehlerstrom-Schutzschalter (RCD) abgesichert sein.

Trennen Sie das Gerät sofort allpolig von der Stromquelle, wenn eine Dichtung, eine Abdeckung, die Netzleitung oder der Netzstecker beschädigt, defekt oder nass sind oder Zeichen von Überhitzung aufweisen. Verwenden Sie das Gerät nicht, bis die Reparatur abgeschlossen ist.

Prüfen Sie vor Inbetriebnahme alle elektrischen Verteilereinrichtungen und Leitungen auf Fehlerfreiheit, ausreichende Dimensionierung für alle angeschlossenen Verbraucher und Eignung für die Installation (Wasser, Verschmutzung, Temperatur, UV-Beständigkeit).

Tauchen Sie das Gerät nicht in Wasser oder eine andere Flüssigkeit ein. Der Montageort darf nicht überflutet werden können.

Die Lichtquelle des Geräts darf nur durch den Hersteller, einen Servicepartner des Herstellers oder eine ähnlich qualifizierte Person ersetzt werden.

Wenn Sie mehrere Geräte in Reihe mit der Stromquelle verbinden, beachten Sie bitte Sicherheitshinweise im Abschnitt „Sicherheitshinweise zum seriellen Anschluss der Geräte“ auf Seite 27.



Schutz vor Verbrennung und Feuer

Verwenden Sie das Gerät nicht bei Umgebungstemperaturen (T_a) über 40° C.

Das Gehäuse des Geräts wird während des Betriebs bei höchster zulässiger Umgebungstemperatur bis zu 55° C warm. Lassen Sie das Gerät nach dem Ausschalten mindestens 5 Minuten abkühlen, bevor Sie es berühren.



Installieren Sie das Gerät nur auf einer nicht brennbaren Oberfläche (Ziegel, Beton, Pflastersteine usw.).

Der Mindestabstand der Lichtaustrittsfläche zu brennbarem Material (Plastik, Holz, Papier usw.) beträgt 0,5 m.

Halten Sie leicht entzündliches Material (Gase, Flüssigkeiten usw.) vom Gerät fern.

Die Luft muss das Gerät ungehindert umströmen können.

Der Freiraum um das Gerät muss mindestens 0,1 m betragen.

Überbrücken Sie niemals Überhitzungs-Schutzschalter oder Sicherungen.

Nehmen Sie an dem Gerät keine Veränderungen, die nicht in dieser Anleitung beschrieben werden, vor. Verwenden Sie nur Original Martin®-Ersatzteile.

Bedecken Sie Linsen und andere optische Komponenten nie mit Filtern, Maskierungen oder anderem Material. Verwenden Sie nur von Martin® freigegebenes Zubehör, um den Lichtstrahl zu maskieren oder zu modifizieren.



Schutz vor Augenverletzung

Nur VDO Atomic Dot CLD: Warnung! Produkt der Risikogruppe 2 gemäß EN 62471 und IEC/TR 62778.

Blicken Sie nicht direkt in die Lichtaustrittsöffnung.

Blicken Sie nicht in einen leuchtenden Scheinwerfer. Gefahr der Augenverletzung.

Blicken Sie nicht mit sammelnden optischen Instrumenten (Lupe, Teleskop, Fernglas usw.) in die Lichtaustrittsöffnung.

Stellen Sie sicher, dass keine Personen in die Lichtaustrittsöffnung blicken können, wenn das Gerät plötzlich aufleuchten könnte. Dies kann beim Einschalten des Geräts, beim Empfang eines DMX-Signals oder beim Öffnen bestimmter Gerätemenü-Punkte passieren.

Trennen Sie das Gerät immer allpolig von der Stromquelle, wenn Sie es nicht verwenden, um die Gefahr der Augenverletzung zu verringern. Die Umgebungshelligkeit soll bei Arbeiten an oder in der Nähe des Geräts hoch sein, um den Pupillendurchmesser des Auges zu verringern.

Der VDO Atomic Dot CLD fällt gemäß EN 62471 und IEC/TR 62778 bei unten angegebenen Abständen in die folgenden Risikogruppen.

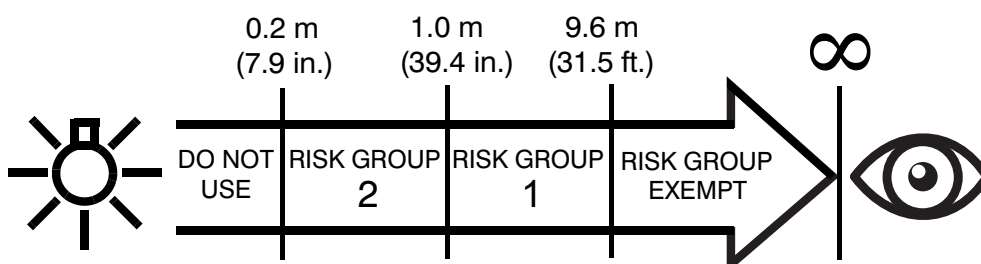

Das Gerät sollte so positioniert werden, das längeres Starren in den Lichtaustritt aus Entfernungen unter 1,0 m nicht zu erwarten ist.



Schutz vor Verletzung

Befestigen Sie das Gerät während des Betriebs sicher an einer Oberfläche oder tragenden Struktur. Das Gerät darf während des Betriebes nicht bewegt werden.

Prüfen Sie vor der Montage des Geräts, ob die tragende Struktur und alle Anschlagmittel mindestens für das Gewicht aller die Struktur belastenden Geräte ausgelegt sind. Beachten Sie alle lokalen Sicherheitsvorschriften und Sicherheitsfaktoren.

Prüfen Sie die korrekte Montage allen Zubehörs, wie Filterrahmen oder Gobohalter.

Sperren Sie den Bereich unterhalb des Geräts und arbeiten Sie von einer stabilen Plattform aus, wenn Sie das Gerät installieren, Wartungsarbeiten ausführen oder bewegen.

Verwenden Sie das Gerät nicht, wenn Abdeckungen, Abschirmungen oder optische Komponenten fehlen oder defekt sind.

Trennen Sie das Gerät sofort allpolig von der Stromquelle, wenn während des Betriebs Probleme auftreten. Verwenden Sie kein Gerät, das offensichtlich beschädigt ist.

Introduction

Thank you for selecting the Martin VDO Atomic Dot product. This versatile product can be used for a wide variety of effects:

- Compact strobe fixture
- Compact blinder fixture
- Compact beam fixture
- Compact video pixel with 16 LEDs of individual control

The VDO Atomic Dot is available in two variants:

- A WRM variant featuring a primary white LED with a color temperature of 2700K
- A CLD variant featuring a primary white LED with a color temperature of 5700K

Both variants also contain 16 individually controllable RGB LEDs for additional Aura effects behind the front-lens.

As the fixture is fully IP65-rated, it is suitable for both indoor and outdoor applications.

Multiple VDO Atomic Dots can be combined together into battens and arrays to create large visual effects, by using the integrated interconnecting mechanics.

The VDO Atomic Dot is compatible with a large variety of lighting and video control protocols, allowing the fixture to be controlled in the most suitable way:

- DMX/RDM
- Art-Net
- sACN
- P3

Power and data is supplied to the fixture via a hybrid cable with hybrid connector that carries power, DMX and Ethernet. This allows many fixtures to be daisy-chained very easily, without requiring multiple cables between them.

The start of a daisy-chain is made at:

- A passive Junction Box that takes standard Power, DMX and Ethernet inputs and merges them into the PDE hybrid connector.
- An active Junction Box which features the same functionality as the passive Junction Box; plus Power, DMX and Ethernet thru connections to relay power and data to another junction box or fixture, including galvanic isolated interfaces to avoid ground loops on system level.
- A Break-In cable which provides the same functionality as the passive Junction Box, but in a more compact cable assembly.

Consult the PDE Junction Box User Manual for more information on these different PDE solutions.

The front of the VDO Atomic Dot features an industry-standard PAR30-sized holder, allowing installation of standard accessories such as diffusers, color filters and barndoors.

Before using the product for the first time

1. Read 'Safety information' on page 8 before installing, operating or servicing the fixture.
2. Unpack and ensure that there is no transportation damage before using the fixture. Do not attempt to operate a damaged fixture.
3. Before operating, ensure that the voltage and frequency of the power supply match the power requirements of the fixture.
4. Obtain a junction box or break-in cable.
5. Check the support pages on the Martin® website at www.martin.com for the most recent user documentation and technical information about the fixture. Martin® user manual revisions are identified by the revision letter at the bottom of the inside cover.

Fixture overview

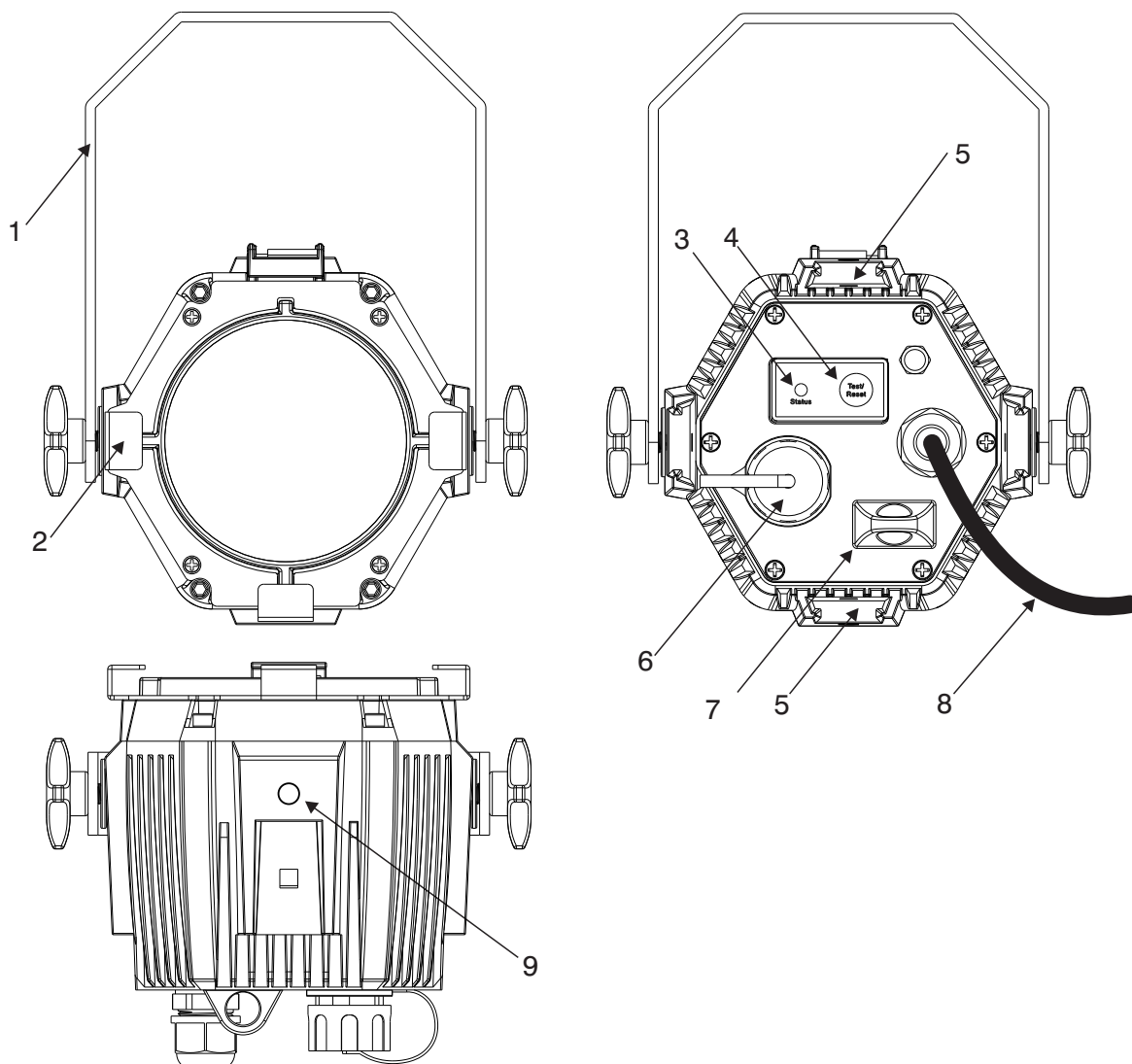

- 1 – Hanging bracket (can be taken off)
- 2 – PAR30 sized holder for diffuser or barndoors
- 3 – Status LED
- 4 – Test / Reset button
- 5 – Interlock slots for interlock accessories (4 slots, one on each side of fixture)
- 6 – Thru connector (chassis mount, with sealing cap)
- 7 – Safety cable attachment point
- 8 – Input cable with connector
- 9 – M8 holes for hanging bracket attachment, maximum bolt length 15 mm (4 holes, one on each side of fixture). May also be used for mounting fixture if standard interlock accessories are not suitable.

Physical installation



Warning! Read 'Safety information' on page 8 before installing the fixture.

Warning! The safety and suitability of lifting equipment, installation location, anchoring method, mounting hardware and electrical installation are the responsibility of the installer. All local safety regulations and legal requirements must be observed when installing and connecting the VDO Atomic Dot fixture and Junction Box. Installation must be carried out by qualified professionals only.

Contact your Martin supplier for assistance if you have any questions about how to install this product safely.

Fixture location

The VDO Atomic Dot fixture and Junction Box is fully IP65 rated and may be used indoors or in a temporary outdoor location.

Observe the following limitations in selecting a location:

- Respect the limitations listed under 'Safety information' on page 8.
- Do not locate the fixture in an unventilated space.

Ways of mounting the fixture



Warning! All fasteners used to mount VDO Atomic Dot fixtures or arrays of fixtures must be strong enough to hold the fixtures safely. Install a washer directly under the head of each fastener when anchoring the mounting bracket to the installation surface.

The fixture has a number of mounting options:

- Via the hanging bracket to a truss or surface
- A VDO Atomic Dot Half Coupler may be attached directly to one of the interlock slots on the fixture (without the hanging bracket)
- Multiple fixtures may be interlocked together using the slide-in Interlock Coupler. A maximum of 16 fixtures may be interlocked in a column. When interlocking fixtures horizontally, a rigging clamp must be used every 3rd fixture to support the array (so a maximum of 2 unsupported fixtures between each supported one)
- A Pivot Interlock Coupler is available which couples fixtures at any multiple of 15 degrees. This allows circles or other shapes of fixtures to be created.
- An Interlock Adaptor is available which attaches to one of the interlock slots enabling you to mount a single VDO Atomic Dot on a microphone stand with standard 5/8 in. thread.
- A Double Width Bracket is available to join 2 fixtures in a 2-lite or 4 fixtures in a 4-lite, which can then be attached to a truss or surface.
- A Spigot Adapter is available to attach a fixture to standard spigot-compatible accessories such as floorplates and stands.
- Safety bonds must be fitted to each fixture, even when fixtures are interlocked, using the safety bond attachment point on the rear.



Warning! The VDO Atomic Dot Half Coupler, Pivot Interlock Coupler, Interlock Adapter and Spigot Adapter are not suitable for permanent outdoor usage. Long term exposure to humidity and pollution can affect the correct and safe functioning of these mechanisms.

Mounting the fixture on a truss using the hanging bracket

The fixture or array of fixtures can be clamped to a truss or similar rigging structure using the hanging bracket which allows adjustment of the fixture angle. Use a suitable rigging clamps such as a G-clamp or a half-coupler clamp fastened to the hanging bracket.



To clamp the fixture or array to a truss:

1. Check that the rigging structure can support at least 10 times the weight of all fixtures and equipment to be installed on it.
2. Block access under the work area.
3. Bolt a rigging clamp securely to the hanging bracket. The bolts used must be M12, grade 8.8 steel minimum, and fastened with a self-locking nut.
4. Working from a stable platform, mount the fixture on the truss and fasten the rigging clamp onto the truss.
5. Attach a safety bond to the fixture and loop around a fixed point.

Mounting 2 or 4 fixtures on a truss using the double width hanging bracket



Two or four fixtures can be joined together using the double width bracket to create a 2-lite or 4-lite fixture. The double width bracket allows adjustment of the fixture angle when clamped to a truss or similar rigging structure. Use a suitable rigging clamp such as a G-clamp or a half-coupler fastened to the hanging bracket.

To create a 2-lite:

1. Put aside the 2 interlinking plates and 4 bolts supplied with the double width bracket. These are not used when creating a 2-lite.
2. Attach two VDO Atomic Dot fixtures side-by-side using a VDO Atomic Dot Coupler (P/N 91610003).
3. Attach the double-width bracket to the joined fixtures using the supplied knobs.
4. Check that the rigging structure can support at least 10 times the weight of all fixtures and equipment to be installed on it.
5. Block access under the work area.
6. Bolt a rigging clamp securely to the double width hanging bracket. The bolts used must be M12, grade 8.8 steel minimum, and fastened with a self-locking nut.
7. Working from a stable platform, mount the fixture-assembly on the truss and fasten the rigging clamp onto the truss.
8. Attach a safety bond to both fixtures and loop around a fixed point.

To create a 4-lite:

1. Attach four VDO Atomic Dot fixtures in a 2 by 2 array using 4x VDO Atomic Dot Couplers (P/N 91610003).
2. Attach the 2 interlinking plates supplied with the double width bracket assembly to the left side and right side of the array, using the supplied M8 bolts, fitted into the M8 holes in the sides of the fixtures.

3. Attach the double-width bracket to the center holes of the interlinking plates, using the supplied knobs.
4. Check that the rigging structure can support at least 10 times the weight of all fixtures and equipment to be installed on it.
5. Block access under the work area.
6. Bolt a rigging clamp securely to the double width hanging bracket. The bolts used must be M12, grade 8.8 steel minimum, and fastened with a self-locking nut.
7. Working from a stable platform, mount the fixture-assembly on the truss and fasten the rigging clamp onto the truss.
8. Attach a safety bond to all four fixtures and loop around a fixed point.

Mounting the fixture on a truss using direct clamp

The VDO Atomic Dot Half Coupler may be directly mounted to the fixture or array of fixtures using one of the interlock slots on any side.



To rig using a directly attached clamp:

1. Check that the rigging structure can support at least 10 times the weight of all fixtures and equipment to be installed on it.
2. Block access under the work area.
3. Slide VDO Atomic Dot Half Couplers into the fixture interlock slot on one or more fixtures as required.
4. Working from a stable platform, lift the fixture(s) to the truss and fasten the half coupler clamp onto the truss.
5. Attach a safety bond to the fixture and loop around a fixed point. Each fixture must have an individual safety bond even when interlocked into an array.

Interlocking multiple fixtures

Multiple fixtures may be interlocked on any side using the slide-in interlock coupler to form arrays of any shape.



To install the Interlock Coupler, locate two fixtures side by side and slide in the coupler (1) from the rear. The coupler has two retention clips which lock into each fixture. Ensure the release key (2) is oriented as shown so that the clips are secured in place.

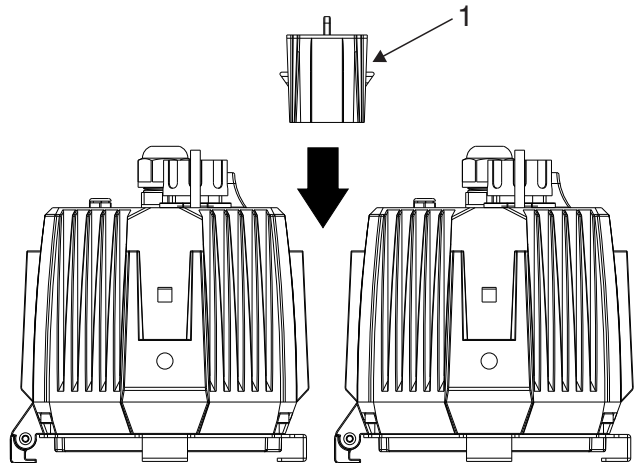

Note:

- A maximum of 16 fixtures may be interlocked in a column.
- When interlocking fixtures horizontally, a rigging clamp must be used every 3rd fixture to support the array (so a maximum of 2 unsupported fixtures between each supported one)

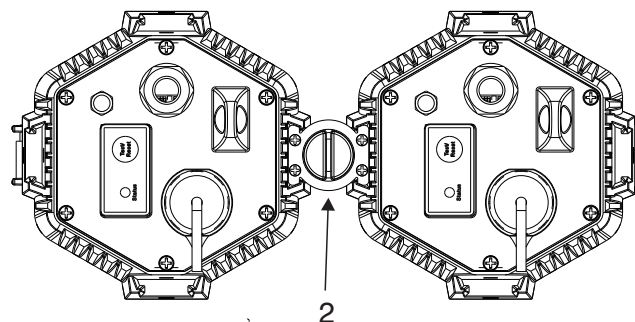
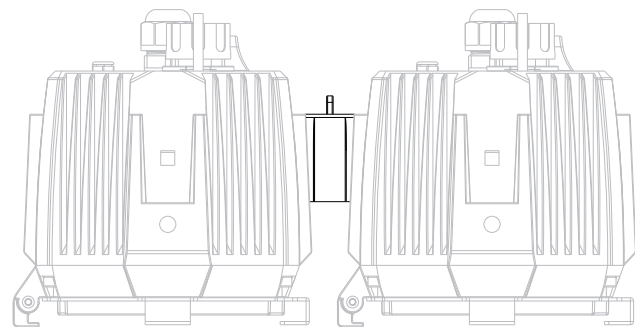

When fixtures are interlocked, the spacing is 150mm.

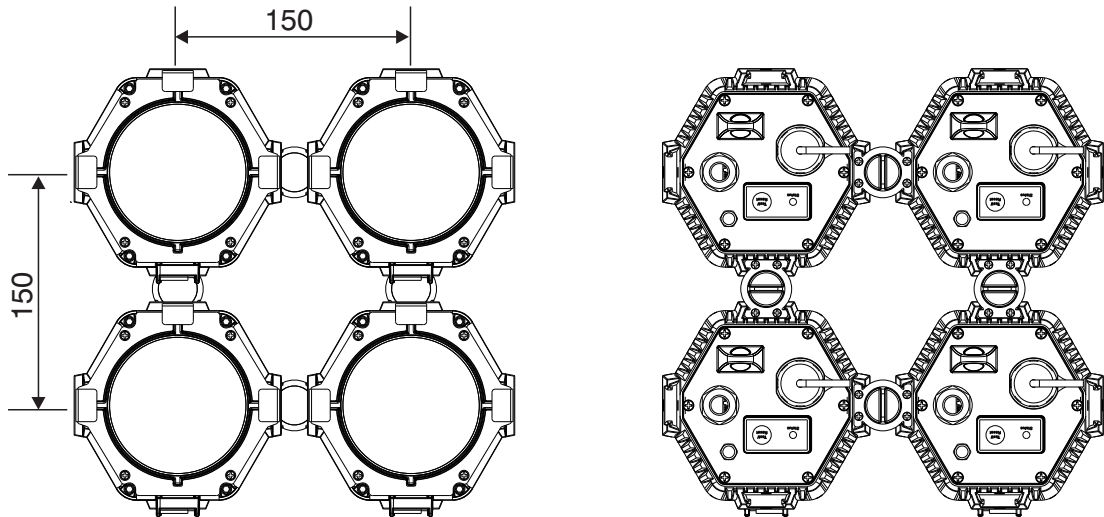

To remove the coupler, twist the release key to retract the clips. The coupler can then be slid out towards the rear of the fixtures.

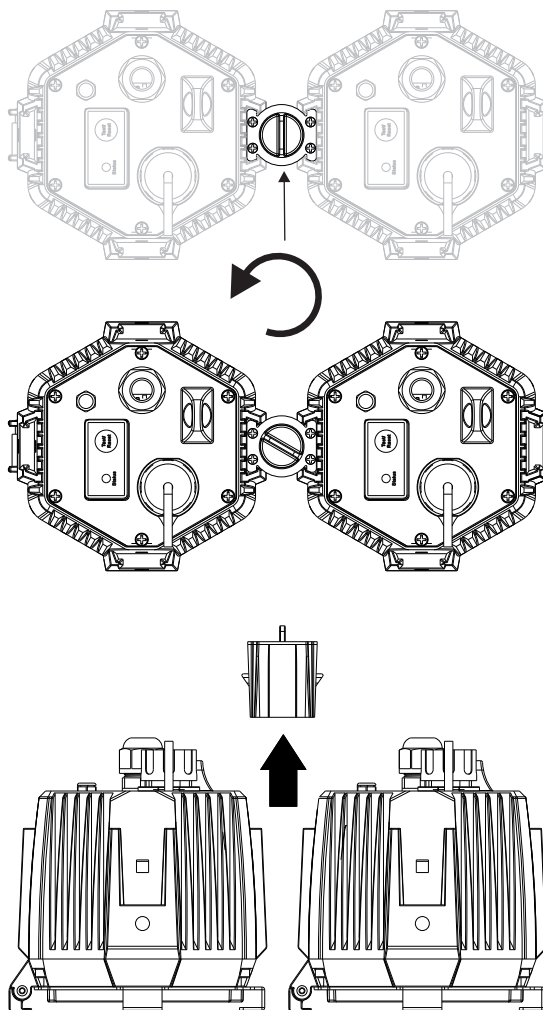

The Pivot Coupler, Half Coupler, Interlock Adapter and Spigot Adapter use the same locking mechanism.

Installing optical accessories

Installing one of the optical accessories available from Martin® for the VDO Atomic Dot takes a few seconds. No tools are required.

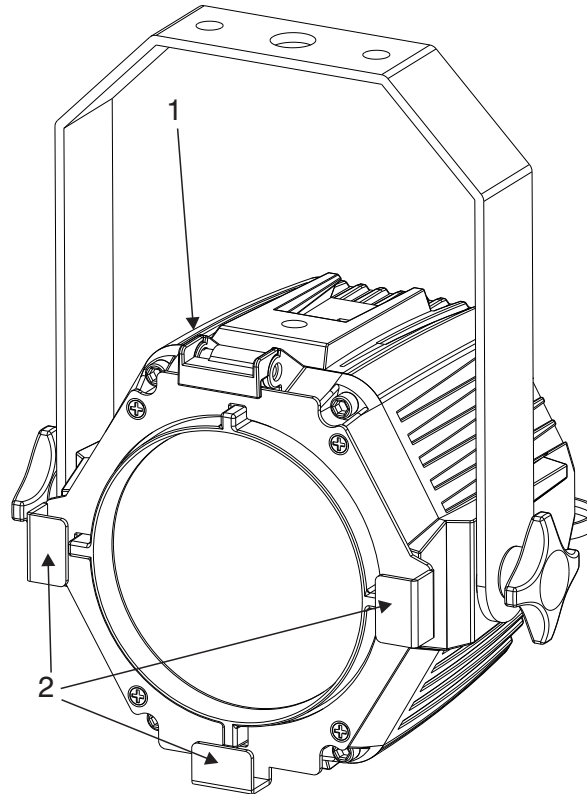

To install an optical accessory:

1. Slide and lift up the hinged retaining clip (1) on the top of the VDO Atomic Dot and hold it back.
2. Slide the optical accessory into the PAR30-sized holders (2) on the front of the fixture, ensuring that the accessory is correctly located on all sides.
3. Gently release the retaining clip and ensure it locks the accessory in position.

When using the Martin VDO Atomic Dot Diffuser, make sure that you insert it with the matt side towards the fixture.

Safety bonds

To protect against the fixtures falling if the main rigging point fails, you should fit a safety bond to the attachment point on the back of each fixture.

If fixtures are linked together into a larger array, you should still attach a safety bond to each fixture since a failure of a coupler could cause parts of the assembly to fall. However to make rigging easier you can attach the top one round a fixed point, then loop the lower safety bonds into each other as shown in the picture.

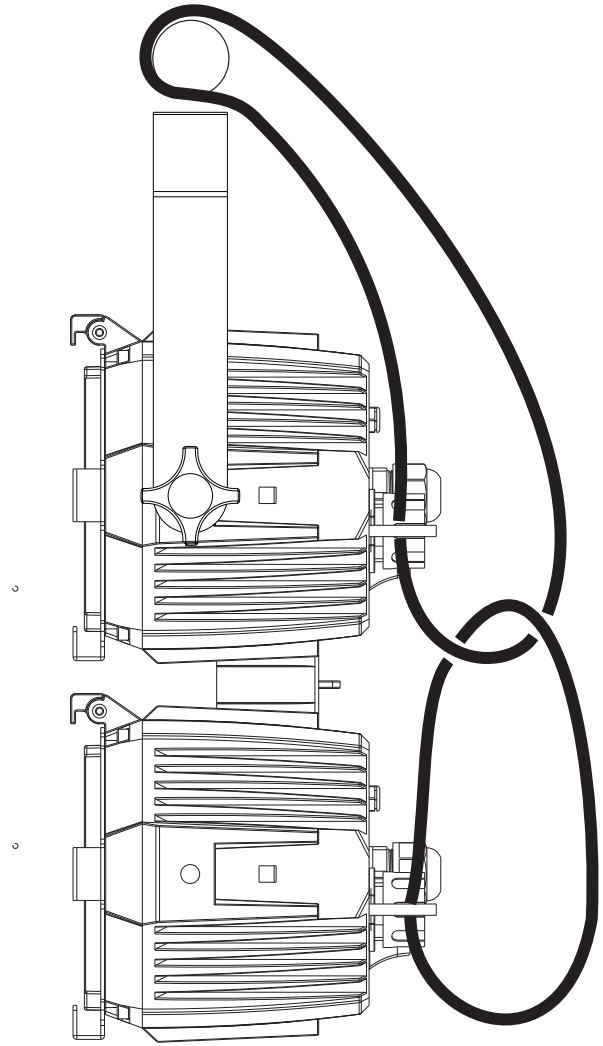

AC power and data connection



Warning! Read 'Safety information' on page 8 before installing the fixture.

For protection from electric shock, the power input to the Junction Box or Break-In cable must be grounded (earthed). The power distribution circuit must be equipped with a 16A fuse or circuit breaker and ground-fault (earth-fault) protection.



AC power and control data are connected to the Junction Box or Break-In cable. Up to 32 VDO Atomic Dot fixtures may then be connected in a daisy chain to each Junction Box or Break-In cable using a hybrid PDE cable which carries both power and data.

Safety limits for connecting devices

As the fixtures are connected in a chain, there is a limit to how many fixtures you can link together and how far apart they can be.

- Maximum of 32 fixtures connected in a chain.
- When DMX is being used as control protocol, the total length of DMX cable and Hybrid PDE cable combined must not exceed 300 m (measured between lighting console, DMX node or DMX splitter and last fixture on the chain).
- When Art-Net, sACN or P3 is being used as control protocol, the combined length of Ethernet cable (between network switch and junction box) and hybrid PDE cable to first fixture must not exceed 90 m. The length of hybrid PDE cable between any two daisy-chained fixtures may also not exceed 90 m.
- Install the sealing cap on the thru connector of the last fixture in the chain.

AC power connection to Junction Box or Break-In cable

Do not use an external dimming system to supply power to the Junction Box or Break-In cable and fixtures, as this may cause damage to the fixtures that is not covered by the product warranty.

Socket outlets or external power switches used to supply the system with power must be located near the system and easily accessible so that the system can easily be disconnected from power.

If you install a power plug on the power cable, install a grounding type (earthed) plug with integral cable grip that is suitable for your local mains voltage at a current of 16A. Follow the plug manufacturer's instructions and connect the wires in the power cable as shown in this table:

	Live or L	Neutral or N	Earth, Ground or ⊕
US system	Black	White	Green
EU system	Brown	Blue	Yellow/green

The fixture has an auto-ranging power supply that accepts AC mains power at 100-240 V at 50/60 Hz. Do not apply AC mains power at any other voltage or frequency to the fixture.

Data connection to Junction Box or Break-In cable

The VDO Atomic Dot fixtures may be controlled by DMX512, Art-Net, sACN, or Martin P3 protocol. The data connection is made to the junction box and then linked to the fixtures via the PDE connections.

Using DMX512

In a DMX-controlled system, an RDM-compliant DMX lighting controller sends a DMX control data signal over a DMX link to the junction boxes / break-in cables of the system, and then over the hybrid link to the VDO Atomic Dot fixtures.

A DMX pass-through connector is only provided on the Active Junction Box. When using a Passive Junction Box or Break-In Cable, and you need to connect multiple chains to the same DMX line, you must use an RDM-compliant splitter as described below (and shown in the diagram below). This example shows the passive PDE junction box being used.

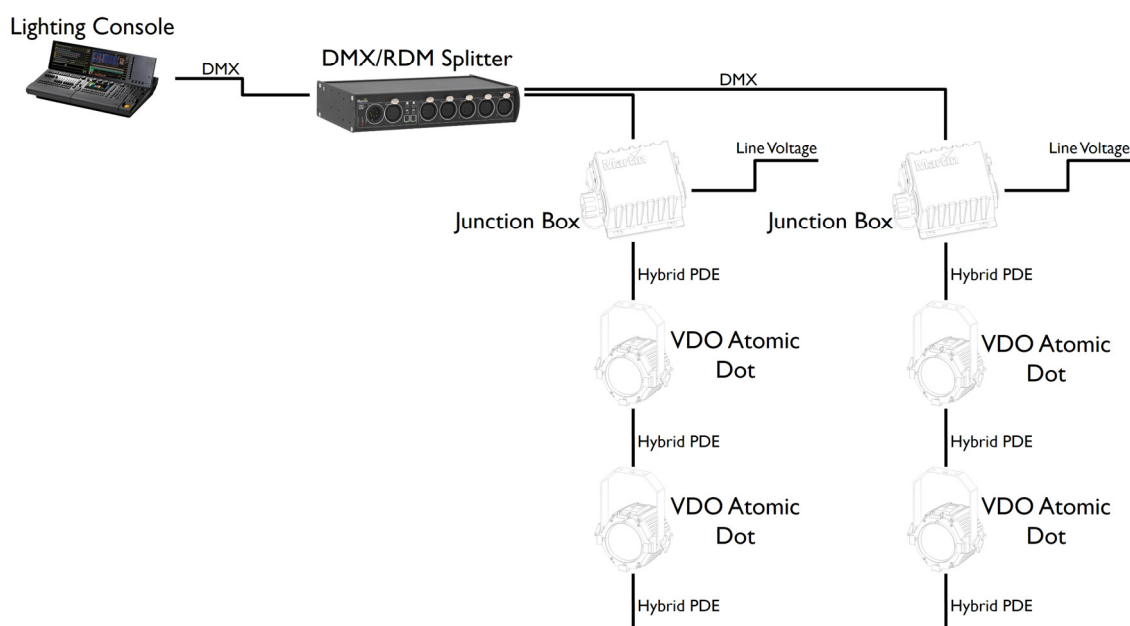

The DMX link requires DMX cable. It can be maximum 300 m (1000 ft.) in length and must run in one single daisy-chain, but it can be extended or split into branches using an RDM-compliant amplifier/splitter. Alternatively, you can run the DMX signal from the controller over Ethernet cable using Art-Net protocol and convert it to a DMX-compliant signal with an Art-Net to DMX converter.

For reliable DMX and RDM data transfer, it is recommended to terminate each branch with a termination plug – this contains a 120 ohm resistor between the cold and hot DMX data lines (pins 2 and 3 on XLR5, pins 4 and 7 on PDE connector). This means that both an unused DMX through port on an Active Junction Box as well as the female PDE connector of the last fixture on a chain needs to be fitted with such a termination plug.

The total length of DMX cable and Hybrid PDE cable combined must not exceed 300 m (measured between lighting console, DMX node or DMX splitter and last fixture on the chain).

If you would like assistance with creating a DMX link, your Martin® supplier will be glad to advise.

The number of VDO Atomic Dots that you can control on one DMX link is limited by the number of DMX channels the dots will use and the 512 DMX channels available in one DMX universe at the DMX controller. Each time you have used 512 channels, you must create a new DMX link that is connected to a new DMX universe on the controller. Note that this limit applies to the *DMX link*. The maximum safety limits that apply to the chain of dots and cable (see “Safety limits for connecting devices” on page 27) take priority and must be respected in all cases.

DMX512 data is connected to the junction box using the XLR5 connector. The pin-out is:

- pin 1 = shield

- pin 2 = cold (-)
- pin 3 = hot (+).

Pins 4 and 5 in the XLR connectors are not used.

Using Art-Net or sACN

Art-Net or sACN data is connected to the system using the etherCON socket on the Junction Box or Break-In Cable. Each Junction Box/Break-In cable must have its own Ethernet connection from a network switch, unless you are using an Active PDE Junction Box, which has an Ethernet thru port, allowing you to daisy chain multiple Active Junction Boxes in an Ethernet chain.

- Please ensure that network switch can operate at 100Mbit Ethernet link speed towards the junction boxes, as the VDO Atomic Dot can only operate at that link speed.
- The combined length of Ethernet cable (between network switch and junction box) and hybrid PDE cable to first fixture must not exceed 90 m. The length of hybrid PDE cable between any two daisy-chained fixtures may also not exceed 90 m.
- A shielded Ethernet cable must be used between the Network Switch and the Junction Box / Break-In Cable. Use shielded twisted-pair Ethernet cable of type S/UTP, SF/UTP, S/STP or SF/STP only. The cable must be rated Cat 5e or better. The cable shield must be electrically connected to connector housings, and the other devices on the data link must also support shielded connections.

This example shows the passive PDE junction box being used.

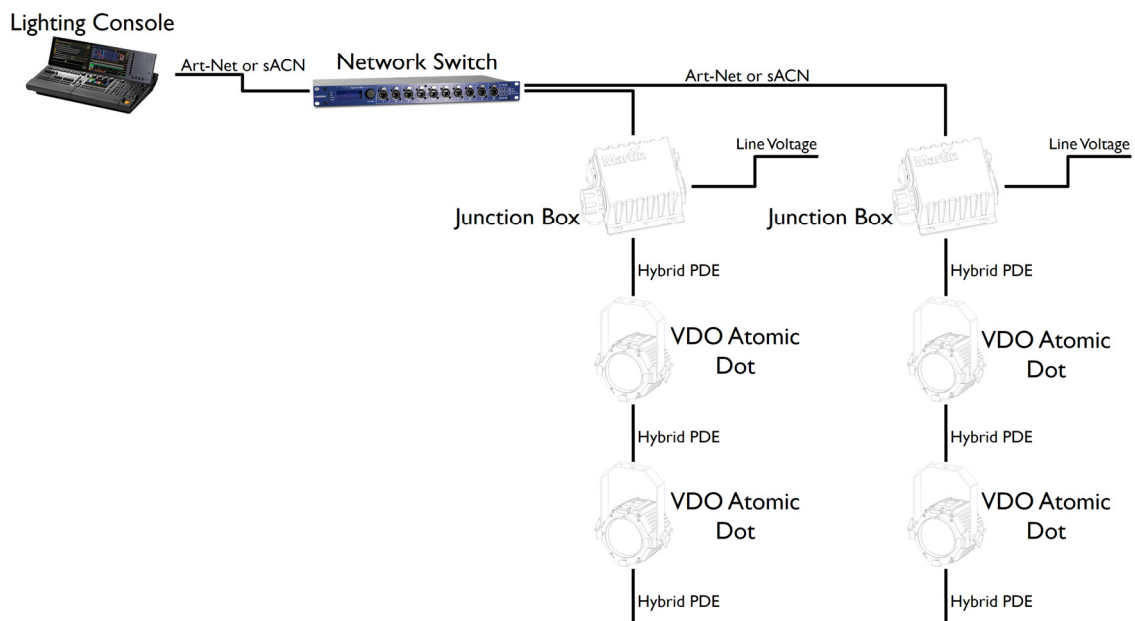

Using P3

The Martin P3 System Controller combines control information from the lighting console with video information from a media server. This is distributed to the fixtures using a network switch. Each Junction Box must have its own Ethernet connection from the network switch, unless you are using an Active PDE Junction Box, which has an Ethernet thru port, allowing you to daisy chain multiple Active Junction Boxes in an Ethernet chain..

- Please ensure that network switch can operate at 100Mbit Ethernet link speed towards junction boxes, as the VDO Atomic Dot can only operate at that link speed.
- Please ensure that network switch can operate at 1Gbit Ethernet link speed towards the P3 System Controller, as it can only operate at that link speed.
- The combined length of Ethernet cable (between network switch and junction box) and hybrid PDE cable to first fixture must not exceed 90 m. The length of hybrid PDE cable between any two daisy-chained fixtures may also not exceed 90 m.
- A shielded Ethernet cable must be used between the Network Switch and the Junction Box / Break-In Cable. Use shielded twisted-pair Ethernet cable of type S/UTP, SF/UTP, S/STP or SF/STP only. The cable must be rated Cat 5e or better. The cable shield must be electrically connected to connector housings, and the other devices on the data link must also support shielded connections.
- Other P3-compatible fixtures such as the MAC Aura PXL and P3 PowerPort 1500 can be connected to the same network switch to operate all together from the same P3 System Controller.

The example below shows a system using a passive PDE junction box.

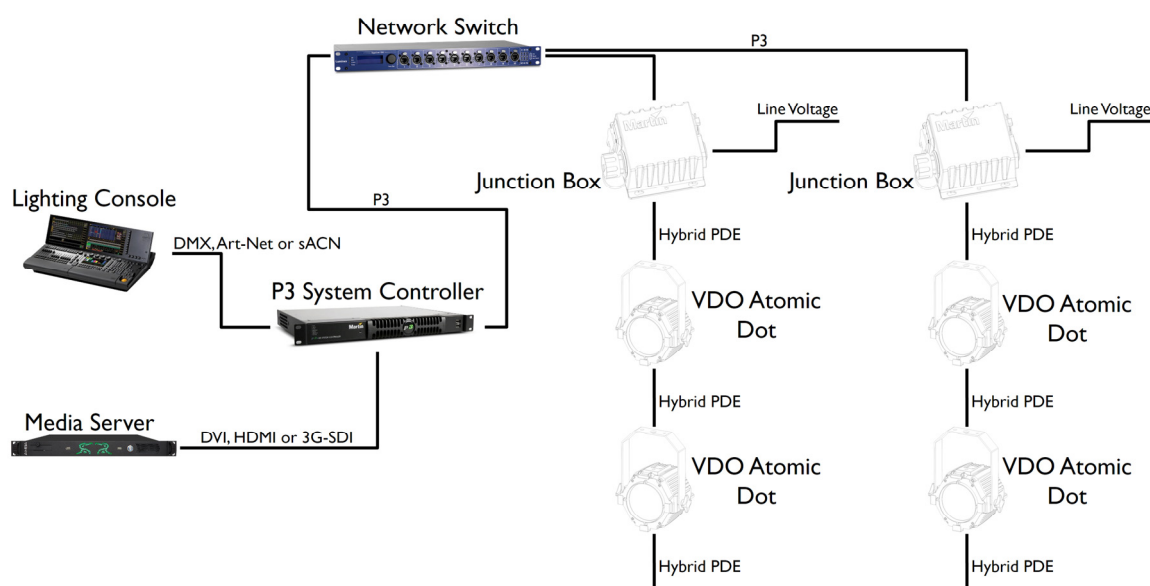

PDE connections between fixtures

The VDO Atomic Dot fixtures are linked to each other and the Junction Box or Break-In cable using a PDE connection which carries both power and data.

- To make the connection, align the pins of the connectors and push together. The connector will lock automatically.
- To remove the connection, twist the locking ring counter-clockwise to unlock and then pull apart.

System Setup

All setup options for the VDO Atomic Dot are configured over the data link.

If you are using a Martin P3 system to control the fixture, please refer to the P3 System Controller user manual and instruction videos.

For DMX, Art-Net and sACN the fixture is configured using RDM.

It is also possible to configure the VDO Atomic Dot fixtures using a P3 System Controller (or P3-PC) to set DMX start addresses, DMX modes, DMX universes and other parameters. Once the fixtures are configured you can then run the fixtures directly using DMX, Art-Net or sACN without using the P3 System Controller.

Setting options by RDM

The VDO Atomic Dot fixture is remotely configured over the DMX line using RDM.

A full list of the RDM functions that the VDO Atomic Dot fixture supports is given at the end of this chapter. These functions are generally referred to using the more specific term 'PIDs' or 'Parameter IDs'.

Scanning for RDM devices on the data link

Before you can communicate with fixtures using RDM, you must send a scan command (also called a device discovery command) to all the devices on the data link so that the RDM controller can identify them. It does this by retrieving each device's factory-set unique identifier (UID). This process can take some time depending on the number of devices on the link.

To identify the fixtures on the link:

1. Check that the fixtures are correctly connected to the RDM controller on the data link and that power is applied to all fixtures.
2. Give the controller time to identify the devices on the link and prepare for communication with the devices.

Getting status and setting options by RDM

The status and options listed in the table below can be read and set by RDM.

You can set an option on one fixture by sending a unicast RDM command to that one fixture only, or you can set the same option on all the fixtures on the data link by sending a broadcast RDM command to all the devices on the link.

For status reading, you can only use unicast RDM to read information from an individual fixture.

Martin Companion and RDM

The Martin Companion Windows application (downloadable free of charge from the Martin website at www.martin.com) gives access to all the fixture's RDM parameters. It supports the fixture's standard and manufacturer-specific PIDs. It gives full control of all fixture settings remotely, eliminating the need to physically climb to the fixture in a rig, for example.

Martin Companion can also update multiple RDM parameters at once, using the built-in Settings Template system.

RDM

As a minimum, the VDO Atomic Dot fixtures support the following RDM functions:

RDM DISCOVERY
DISC_UNIQUE_BRANCH
DISC_MUTE
DISC_UN_MUTE

STATUS COLLECTION	GET	SET
QUEUED_MESSAGE	✓	
STATUS_MESSAGES	✓	
STATUS_ID_DESCRIPTION	✓	
CLEAR_STATUS_ID		✓

RDM INFORMATION	GET	SET
SUPPORTED_PARAMETERS	✓	
PARAMETER_DESCRIPTION	✓	

PRODUCT INFORMATION	GET	SET
DEVICE_INFO	✓	
DEVICE_MODEL_DESCRIPTION	✓	
MANUFACTURER_LABEL	✓	
DEVICE_LABEL	✓	✓
FACTORY_DEFAULTS	✓	✓
SOFTWARE_VERSION_LABEL	✓	

DMX SETUP	GET	SET
DMX_PERSONALITY	✓	✓
DMX_PERSONALITY_DESCRIPTION	✓	
DMX_START_ADDRESS	✓	✓
SLOT_DESCRIPTION	✓	

SENSORS	GET	SET
SENSOR_DEFINITION	✓	
SENSOR_VALUE	✓	✓

USAGE INFORMATION	GET	SET
DEVICE_HOURS	✓	
DEVICE_POWER_CYCLES	✓	

CONTROL	GET	SET
IDENTIFY_DEVICE	✓	✓
RESET_DEVICE		✓
PERFORM_SELFTEST	✓	✓
SELF_TEST_DESCRIPTION	✓	

NETWORK CONFIGURATION	GET	SET
LIST_INTERFACES	✓	
INTERFACE_LABEL	✓	
INTERFACE_HARDWARE_ADDRESS_TYPE1	✓	
IPV4_DHCP_MODE	✓	
IPV4_CURRENT_ADDRESS	✓	
IPV4_STATIC_ADDRESS	✓	✓
INTERFACE_APPLY_CONFIGURATION		✓

MARTIN CUSTOM	GET	SET
DMX_RESET_ENABLE	✓	✓
FIXTURE_ID	✓	✓
DIMMER_CURVE	✓	✓
VIDEO_TRACKING	✓	✓
STROBE_BEHAVIOR	✓	✓
SERIAL_NUMBER	✓	

Using the VDO Atomic Dot



Warning! Read ‘Safety information’ on page 8 before applying power to the VDO Atomic Dot.

Do not use the VDO Atomic Dot if the ambient temperature exceeds 40° C (104° F) or falls below 0° C (32° F).

Thermal regulation

The VDO Atomic Dot uses passive cooling without a fan, and controls its temperature by dimming down automatically if it gets too hot, for example on full white it will dim after about 10 seconds to a lower intensity. At high ambient temperatures the output will also be reduced.

Video display using P3

The VDO Atomic Dot can display video from all common video sources. The video signal must be sent to a Martin® P3 controller and then distributed to fixtures. The P3 controller lets you map, configure and control an installation containing VDO Atomic Dots (and other Martin® P3 video display products if you have them).

Once the VDO Atomic Dot fixtures are mapped and addressed on the P3 System Controller, it is possible to map video onto them, while still having control from the lighting desk. At any given moment the output from the fixture can be controlled by video content, DMX channels, internal effect macros or a mix.

See the P3 controller documentation for details.

DMX control

The VDO Atomic Dot can display effects controlled by DMX (either using the 5-pin XLR, via Art-Net / sACN or via DMX sent through the P3 System Controller).

Five DMX modes are available:

- **1 channel** mode: uses a single DMX channel and operates the fixture as a white “blinder” with automatic tungsten fade effect
- **3 channel** mode: gives strobe functionality of intensity / duration / rate, same as Atomic 3000 DMX/LED (no backlight functions)
- **4 channel** mode: As 3 channel mode but with an additional effects channel, same as Atomic 3000 DMX/LED (no backlight functions)
- **Basic** mode: uses 19 DMX channels and gives RGB color mixing of backlight/aura, strobe effects and pre-programmed dynamic effects. P3 video data can also be superimposed or mixed under DMX control.
- **Extended** mode: uses 64 DMX channels to add to Basic mode by allowing individual control of the 16 LEDs in the backlight/aura. P3 video data can also be superimposed or mixed under DMX control.

See “DMX protocols” on page 38 for full details of DMX control.

An RDM-compatible DMX controller or P3 System Controller is required so that you can address and configure the fixtures. See the DMX/RDM controller documentation for details.

LED PWM frequency control

The PWM frequency of the VDO Atomic Dot LEDs has been chosen carefully to avoid flickering on camera. In some rare situations – for example when using cameras with non-standard settings – it may be necessary to adjust the LED PWM frequency manually.

From firmware version 1.4.0, you can adjust the PWM frequency via DMX by sending value 255 on the FX Selection channel. Once activated, the FX Speed and Direction channel will control the LED PWM frequency. Note that this change is not stored permanently in the fixture, so you have to keep the FX Selection and FX Speed/Direction channels at the chosen values in order to keep the LED PWM frequency at the corresponding custom value.

You can adjust PWM frequency as follows:

DMX value sent on FX Speed and Direction Channel	LED PWM frequency
0	2400Hz (Default PWM frequency)
1-127	Adjustment in steps from 2400Hz to 3000Hz
128	3000Hz
129-254	No function
255	High speed PWM Frequency Mode (24000Hz)

Status LED

The only user controls on the VDO Atomic Dot are a status LED and a pushbutton. The function of these is described below.

LED indication	Meaning
Blue Constant	Busy (e.g. booting up or writing to flash memory)
Red Constant	Error. The fixture has encountered a fatal error and cannot run.
Red Flashing	No control source detected (no protocols detected on DMX or Ethernet).
Green Flashing	Ready. P3 packets detected, but fixture not in joined state.
Green Constant	Running normally in P3 mode (P3 joined).
Cyan Flashing	Ready. Fixture in DMX mode but not receiving valid DMX data.
Cyan Constant	Running normally in DMX mode.
Yellow Constant	Overtemperature.
Magenta Flashing	Ready. Fixture in Art-Net or sACN mode but not receiving valid DMX data.
Magenta Constant	Running normally in Art-Net or sACN mode.

Pushbutton functions

The pushbutton can be used to activate internal test patterns within the fixture, perform a fixture reboot or perform a factory reset of the fixture (just like other Martin LED Video fixtures).

If the pushbutton is given a short press, the first internal test pattern is activated. If the pushbutton is then given another short press, the next internal test pattern is activated. This way the user can “step” through the different internal test patterns.

- Press once: 16 backlight LEDs to full red
- Press again: 16 backlight LEDs to full green
- Press again: 16 backlight LEDs to full blue
- Press again: 16 backlight LEDs to full white
- Press again: White beam LED at full on (backlight LEDs off)
- Press again: Dynamic test pattern activated

Press again: Test patterns stopped, fixture returns to normal operation

If the button is pressed, and kept held in for 5 seconds, the Status LED will turn blue. If the user then releases the button, the fixture will perform a normal reboot.

If the button is pressed, and kept held in for 8 seconds, the Status LED will turn white. If the user then releases the button, the fixture will perform a factory reset (return to factory default/backup firmware image).

Maintenance



Read Safety information on page 8 before maintaining the fixture. Always comply with the safety instructions.

Refer any service operation not described in this user manual to a qualified service technician.

Excessive dust, smoke fluid, and particle buildup degrades performance, causes overheating and will damage the fixture. Damage caused by inadequate cleaning or maintenance is not covered by the product warranty.

Disconnect mains power before cleaning or servicing the fixture.

Fixtures must be serviced in an area where there is no risk of anyone being injured by failing parts, tools or other materials.

Cleaning

Cleaning schedules vary depending on the operating environment. It is therefore impossible to specify precise cleaning intervals for the VDO Atomic Dot. Environmental factors that may result in a need for frequent cleaning include airborne dust and pollution.

Inspect products frequently to see whether cleaning is necessary. If in doubt, consult your Martin® dealer about a suitable maintenance schedule.

To clean the product, use warm water and a soft brush or a low-pressure or medium-pressure water jet. Use car shampoo to help remove dirt and grease. If possible, dry with a soft cloth to avoid streaking. Do not use a stiff brush or scouring pad. Do not use solvents or abrasives.

LED performance

Martin® use the best components available, but the characteristics of all LEDs change gradually over many thousands of hours of use. Not all colors change at the same rate, and rates of change vary depending on factors such as temperature and how intensively a particular color is used. Because of the changes, overall light output and the exact hues obtained from specific color mixes in all LED-based products can be expected to shift slightly over time.

To help you obtain consistent output despite these changes, Martin® P3 software from version 4.1.0 contains the P3 Fixture Adjuster tool. This feature lets you compensate for changes in LED characteristics and restore initial output and color authenticity levels. Please contact Martin® for more details.

Installing new software

It may be necessary to upload new software (i.e. device firmware) to the VDO Atomic Dot if it appears to have a software-related fault or if you want to update to a newer software version. Software for Martin® products is available from the Martin® website.

The VDO Atomic Dot software can be installed from the P3 System Controller over the P3 data link. See the P3 System Controller user manual for software installation instructions.

Alternatively software may be installed over the DMX data link using the Martin Companion cable and Martin Companion application.

DMX protocol

The VDO Atomic Dot has five possible DMX modes

DMX Mode	DMX channels	Functions
1 channel	1	Single channel “blinder” with automatic tungsten effect
3 channel	3	As Atomic 3000 DMX/LED (no backlight)
4 channel	4	As Atomic 3000 DMX/LED (no backlight)
Basic	19	Including Aura backlight control and P3 mode control
Extended	64	As Basic mode, but including individual control over 16 Aura backlight pixels

- While in Basic mode the DMX control of the Aura backlight does not offer individual pixel control, the pixels can still be driven individually using the P3 System Controller pixels.

DMX mode 1 channel

Channel	Value	Function	Fade Status	Default Value
1		Dimmer	Fade	0
	0 - 255	Close → Open		

Notes:

- Fixture will automatically reduce intensity to control temperature when running at high power for too long
- Aura Backlight will be driven automatically to emulate tungsten effect

DMX mode 3 channel

Channel	Value	Function	Fade Status	Default Value
1		Beam Flash Intensity	Snap	0
	0	Blackout		
	1 - 255	Minimum → Maximum Intensity		
2		Beam Flash Duration	Snap	0
	0 - 255	7 → 650 ms		
3		Beam Flash Rate	Snap	0
	0 - 255	0.289 → 16.67 Hz		

Notes:

- Fixture will automatically reduce intensity to control temperature when running at high power for too long
- Aura Backlight is not used in this mode
- As Atomic 3000 DMX/LED 3-Channel Mode

DMX mode 4 channel

Channel	Value	Function	Fade Status	Default Value
1		Beam Flash Intensity	Snap	0
	0	Blackout		
	1 - 255	Minimum → Maximum Intensity		
2		Beam Flash Duration	Snap	0
	0 - 255	7 → 650 ms		
3		Beam Flash Rate	Snap	0
	0 - 255	0.289 → 16.67 Hz		
4		Beam Special Effects	Snap	0
	0 - 5	No Effect		
	6 - 42	Ramp Up		
	43 - 85	Ramp Down		
	86 - 128	Ramp Up, Down		
	129 - 171	Random		
	172 - 214	Lightning		
	215 - 255	Spikes (flash over low light)		

Notes:

- Fixture will automatically reduce intensity to control temperature when running at high power for too long
- Aura Backlight is not used in this mode
- As Atomic 3000 DMX/LED 4-Channel Mode

DMX mode Basic

Basic	Value	Function	Fade Status	Default Value
1 - 2		Beam Flash Intensity	Snap	0
	0	Blackout		
	1 - 65535	Minimum → Maximum Intensity		
3		Beam Flash Duration	Snap	0
	0 - 255	7 → 650 ms		
4		Beam Flash Rate	Snap	0
	0 - 255	0.289 → 16.67 Hz		
5		Beam Special Effects	Snap	0
	0 - 5	No Effect		
	6 - 42	Ramp Up		
	43 - 85	Ramp Down		
	86 - 128	Ramp Up, Down		
	129 - 171	Random		
	172 - 214	Lightning		
	215 - 255	Spikes (flash over low light)		
6		Beam P3 Mode	Snap	0

Basic	Value	Function	Fade Status	Default Value
	0 - 26	<u>DMX-Mode</u> Output of beam LED is fully controlled by channel 1-5 (P3 pixels are ignored)		
	27 - 228	<u>Mix-Mode</u> Output of beam LED is defined by mix of: - Channel 1-5 - P3 pixels (range 27 to 228 performs cross-fade between the two)		
	229 - 255	<u>Video-Mode</u> P3 pixels are used as basis on top of which channel 1-5 are applied		
7		Control / Settings	Snap	0
	0 - 9	No Function		
	10 - 14	Reset Entire Fixture - 5 sec		
	15 - 22	No Function		
	23	Linear Dimming Curve - 1 sec		
	24	Square Law Dimming Curve - 1 sec		
	25	Inverse Square Law Dimming Curve - 1 sec		
	26	S-Curve Dimming Curve - 1 sec		
	27 - 35	No Function		
	36	Enable Video Tracking		
	37	Disable Video Tracking		
	38 - 58	No Function		
	59	Strobe Behavior = LED		
	60	Strobe Behavior = Xenon		
61 - 255	No Function			
8		FX Select	Snap	0
	0	No FX		
	1-254	FX Selection (see table)		
	255	Enable PWM frequency adjustment (adjust frequency on channel 9)		
9		FX Speed / Modifier (depending on effect)	Fade	128
	0 – 126	Rev Fast → Slow		
	127 – 128	Stop		
	129 – 255	Slow → Fast		
10		FX Synchronization	Snap	0
	0	No Sync		
	1	Fixture Offset 10 Degree		
	2	Fixture Offset 20 Degree		
	3-34	Fixture Offset...		
	35	Fixture Offset 350 Degree		
	36	Synchronized		
	37-100	No Function		
	101 – 120	Random Start		
	121 - 140	Random Duration		
141 - 255	No Function			

Basic	Value	Function	Fade Status	Default Value
11		Aura Strobe Effect	Snap	0
	0 - 49	No Strobe		
	50 - 200	Strobe, Slow → Fast		
	201 - 210	No Strobe		
	211 - 255	Random Strobe, Slow → Fast		
12 - 13		Aura Dimmer	Fade	0
	0 - 65535	Close → Open		
14		Aura CTC	Fade	0
	0 – 10	Disabled (Still controllable from P3 System Controller, when used)		
	11-191	2000K to 11000K in 50K steps (11=2000K, 101=6500K, 191=11000K)		
	192-255	11000K		
15		Aura Color Presets	Snap	0
	0 - 10	None, mix color via RGB		
	11 - 15	Color 1 - Moroccan pink		
	16 - 20	Color 2 - Pink		
	21 - 25	Color 3 - Special rose pink		
	26 - 30	Color 4 - Follies pink		
	31 - 35	Color 5 - Fuchsia pink		
	36 - 40	Color 6 - Surprise pink		
	41 - 45	Color 7 - Congo Blue		
	46 - 50	Color 8 - Tokyo Blue		
	51 - 55	Color 9 - Deep Blue		
	56 - 60	Color 10 - Just Blue		
	61 - 65	Color 11 - Medium Blue		
	66 - 70	Color 12 - Double CT Blue		
	71 - 75	Color 13 - Slate Blue		
	76 - 80	Color 14 - Full CT Blue		
	81 - 85	Color 15 - Half CT Blue		
	86 - 90	Color 16 - Steel Blue		
	91 - 95	Color 17 - Lighter Blue		
	96 - 100	Color 18 - Light Blue		
	101 - 105	Color 19 - Medium Blue Green		
	106 - 110	Color 20 - Dark Green		
	111 - 115	Color 21 - Primary Green		
	116 - 120	Color 22 - Moss Green		
	121 - 125	Color 23 - Fern Green		
	126 - 130	Color 24 - JAS Green		
	131 - 135	Color 25 - Lime Green		
	136 - 140	Color 26 - Spring Yellow		
	141 - 145	Color 27 - Deep Amber		
	146 - 150	Color 28 - Chrome Orange		
	151 - 155	Color 29 - Orange		
	156 - 160	Color 30 - Gold Amber		
	161 - 165	Color 31 - Millennium Gold		
166 - 170	Color 32 - Deep Golden Amber			

Basic	Value	Function	Fade Status	Default Value
	171 - 175	Color 33 - Flame Red		
	176 - 180	Color 34 - Magenta		
	181 - 185	Color 35 - Medium Lavender		
	186 - 190	Color 36 - White		
	191 - 214	Color Wheel Rotation Fast → Slow		
	215 - 219	Color Wheel Rotation Stop (stop on last color)		
	220 - 243	Color Wheel Rotation Inverse Slow → Fast		
	244 - 247	Random Colors Fast		
	248 - 251	Random Colors Medium		
	252 - 255	Random Colors Slow		
16		Aura P3 Mode	Snap	0
	0 - 26	<u>DMX-Mode</u> Color of Aura LEDs is fully controlled by channel 17-19 (Aura Red, Green & Blue) (P3 pixels are ignored)		
	27 - 228	<u>Mix-Mode</u> Color of Aura LEDs is defined by mix of: - Channel 17-19 (Aura Red, Green & Blue) - P3 pixels (range 27 to 228 performs cross-fade between the two)		
	229 - 255	<u>Video-Mode</u> Color and brightness of Aura LEDs is driven by P3 pixels, but Aura Red/Green/Blue channels 17-19 keep ability to "color" the video.		
17		Aura Red	Fade	255
	0 - 255	0 → 100%		
18		Aura Green	Fade	255
	0 - 255	0 → 100%		
19		Aura Blue	Fade	255
	0 - 255	0 → 100%		

Notes:

- Fixture will automatically reduce intensity to control temperature when running at high power for too long

DMX mode Extended

Extended	Value	Function	Fade Status	Default Value
1 - 2		Beam Flash Intensity	Snap	0
	0	Blackout		
	1 - 65535	Minimum → Maximum Intensity		
3		Beam Flash Duration	Snap	0
	0 - 255	7 → 650 ms		
4		Beam Flash Rate	Snap	0
	0 - 255	0.289 → 16.67 Hz		
5		Beam Special Effects	Snap	0

Extended	Value	Function	Fade Status	Default Value
	0 - 5	No Effect		
	6 - 42	Ramp Up		
	43 - 85	Ramp Down		
	86 - 128	Ramp Up, Down		
	129 - 171	Random		
	172 - 214	Lightning		
	215 - 255	Spikes (flash over low light)		
6		Beam P3 Mode	Snap	0
	0 - 26	<u>DMX-Mode</u> Output of beam LED is fully controlled by channel 1-5 (P3 pixels are ignored)		
	27 - 228	<u>Mix-Mode</u> Output of beam LED is defined by mix of: - Channel 1-5 - P3 pixels (range 27 to 228 performs cross-fade between the two)		
	229 - 255	<u>Video-Mode</u> P3 pixels are used as basis on top of which channel 1-5 are applied		
7		Control / Settings	Snap	0
	0 - 9	No Function		
	10 - 14	Reset Entire Fixture - 5 sec		
	15 - 22	No Function		
	23	Linear Dimming Curve - 1 sec		
	24	Square Law Dimming Curve - 1 sec		
	25	Inverse Square Law Dimming Curve - 1 sec		
	26	S-Curve Dimming Curve - 1 sec		
	27 - 35	No Function		
	36	Enable Video Tracking		
	37	Disable Video Tracking		
	38 - 58	No Function		
	59	Strobe Behavior = LED		
	60	Strobe Behavior = Xenon		
	61 - 255	No Function		
8		FX Select	Snap	0
	0	No FX		
	1-254	FX Selection (see table)		
	255	Enable PWM frequency adjustment (adjust frequency on channel 9)		
9		FX Speed / Modifier (depending on effect)	Fade	128
	0 – 126	Rev Fast → Slow		
	127 – 128	Stop		
	129 – 255	Slow → Fast		
10		FX Synchronization	Snap	0
	0	No Sync		
	1	Fixture Offset 10 Degree		

Extended	Value	Function	Fade Status	Default Value
	2	Fixture Offset 20 Degree		
	3-34	Fixture Offset...		
	35	Fixture Offset 350 Degree		
	36	Synchronized		
	37-100	No Function		
	101 – 120	Random Start		
	121 - 140	Random Duration		
	141 - 255	No Function		
11		Aura Strobe Effect	Snap	0
	0 - 49	No Strobe		
	50 - 200	Strobe, Slow → Fast		
	201 - 210	No Strobe		
	211 - 255	Random Strobe, Slow → Fast		
12 - 13		Aura Dimmer	Fade	0
	0 - 65535	Close → Open		
14		Aura CTC	Fade	0
	0 – 10	Disabled (Still controllable from P3 System Controller, when used)		
	11-191	2000K to 11000K in 50K steps (11=2000K, 101=6500K, 191=11000K)		
	192-255	11000K		
15		Aura Color Presets	Snap	0
	0 - 10	None, mix color via RGB		
	11 - 15	Color 1 - Moroccan pink		
	16 - 20	Color 2 - Pink		
	21 - 25	Color 3 - Special rose pink		
	26 - 30	Color 4 - Follies pink		
	31 - 35	Color 5 - Fuchsia pink		
	36 - 40	Color 6 - Surprise pink		
	41 - 45	Color 7 - Congo Blue		
	46 - 50	Color 8 - Tokyo Blue		
	51 - 55	Color 9 - Deep Blue		
	56 - 60	Color 10 - Just Blue		
	61 - 65	Color 11 - Medium Blue		
	66 - 70	Color 12 - Double CT Blue		
	71 - 75	Color 13 - Slate Blue		
	76 - 80	Color 14 - Full CT Blue		
	81 - 85	Color 15 - Half CT Blue		
	86 - 90	Color 16 - Steel Blue		
	91 - 95	Color 17 - Lighter Blue		
	96 - 100	Color 18 - Light Blue		
	101 - 105	Color 19 - Medium Blue Green		
	106 - 110	Color 20 - Dark Green		
	111 - 115	Color 21 - Primary Green		
	116 - 120	Color 22 - Moss Green		
121 - 125	Color 23 - Fern Green			
126 - 130	Color 24 - JAS Green			

Extended	Value	Function	Fade Status	Default Value
	131 - 135	Color 25 - Lime Green		
	136 - 140	Color 26 - Spring Yellow		
	141 - 145	Color 27 - Deep Amber		
	146 - 150	Color 28 - Chrome Orange		
	151 - 155	Color 29 - Orange		
	156 - 160	Color 30 - Gold Amber		
	161 - 165	Color 31 - Millennium Gold		
	166 - 170	Color 32 - Deep Golden Amber		
	171 - 175	Color 33 - Flame Red		
	176 - 180	Color 34 - Magenta		
	181 - 185	Color 35 - Medium Lavender		
	186 - 190	Color 36 - White		
	191 - 214	Color Wheel Rotation Fast → Slow		
	215 - 219	Color Wheel Rotation Stop (stop on last color)		
	220 - 243	Color Wheel Rotation Inverse Slow → Fast		
	244 - 247	Random Colors Fast		
	248 - 251	Random Colors Medium		
	252 - 255	Random Colors Slow		
16		Aura P3 Mode	Snap	0
	0 - 26	<u>DMX-Mode</u> Color of Aura LEDs is fully controlled by channel 17-64 (Aura Red, Green & Blue) (P3 pixels are ignored)		
	27 - 228	<u>Mix-Mode</u> Color of Aura LEDs is defined by mix of: - Channel 17-64 (Aura Red, Green & Blue) - P3 pixels (range 27 to 228 performs cross-fade between the two)		
	229 - 255	<u>Video-Mode</u> Color and brightness of Aura LEDs is driven by P3 pixels, but Aura Red/Green/Blue channels 17-64 keep ability to "color" the video.		
17		Aura Red Pixel 1	Fade	255
	0 - 255	0 → 100%		
18		Aura Green Pixel 1	Fade	255
	0 - 255	0 → 100%		
19		Aura Blue Pixel 1	Fade	255
	0 - 255	0 → 100%		
20		Aura Red Pixel 2	Fade	255
	0 - 255	0 → 100%		
21		Aura Green Pixel 2	Fade	255
	0 - 255	0 → 100%		
22		Aura Blue Pixel 2	Fade	255
	0 - 255	0 → 100%		
23		Aura Red Pixel 3	Fade	255
	0 - 255	0 → 100%		

Extended	Value	Function	Fade Status	Default Value
24		Aura Green Pixel 3	Fade	255
	0 - 255	0 → 100%		
25		Aura Blue Pixel 3	Fade	255
	0 - 255	0 → 100%		
26		Aura Red Pixel 4	Fade	255
	0 - 255	0 → 100%		
27		Aura Green Pixel 4	Fade	255
	0 - 255	0 → 100%		
28		Aura Blue Pixel 4	Fade	255
	0 - 255	0 → 100%		
29		Aura Red Pixel 5	Fade	255
	0 - 255	0 → 100%		
30		Aura Green Pixel 5	Fade	255
	0 - 255	0 → 100%		
31		Aura Blue Pixel 5	Fade	255
	0 - 255	0 → 100%		
32		Aura Red Pixel 6	Fade	255
	0 - 255	0 → 100%		
33		Aura Green Pixel 6	Fade	255
	0 - 255	0 → 100%		
34		Aura Blue Pixel 6	Fade	255
	0 - 255	0 → 100%		
35		Aura Red Pixel 7	Fade	255
	0 - 255	0 → 100%		
36		Aura Green Pixel 7	Fade	255
	0 - 255	0 → 100%		
37		Aura Blue Pixel 7	Fade	255
	0 - 255	0 → 100%		
38		Aura Red Pixel 8	Fade	255
	0 - 255	0 → 100%		
39		Aura Green Pixel 8	Fade	255
	0 - 255	0 → 100%		
40		Aura Blue Pixel 8	Fade	255
	0 - 255	0 → 100%		
41		Aura Red Pixel 9	Fade	255
	0 - 255	0 → 100%		
42		Aura Green Pixel 9	Fade	255
	0 - 255	0 → 100%		
43		Aura Blue Pixel 9	Fade	255
	0 - 255	0 → 100%		
44		Aura Red Pixel 10	Fade	255
	0 - 255	0 → 100%		
45		Aura Green Pixel 10	Fade	255
	0 - 255	0 → 100%		
46		Aura Blue Pixel 10	Fade	255
	0 - 255	0 → 100%		

Extended	Value	Function	Fade Status	Default Value
47		Aura Red Pixel 11	Fade	255
	0 - 255	0 → 100%		
48		Aura Green Pixel 11	Fade	255
	0 - 255	0 → 100%		
49		Aura Blue Pixel 11	Fade	255
	0 - 255	0 → 100%		
50		Aura Red Pixel 12	Fade	255
	0 - 255	0 → 100%		
51		Aura Green Pixel 12	Fade	255
	0 - 255	0 → 100%		
52		Aura Blue Pixel 12	Fade	255
	0 - 255	0 → 100%		
53		Aura Red Pixel 13	Fade	255
	0 - 255	0 → 100%		
54		Aura Green Pixel 13	Fade	255
	0 - 255	0 → 100%		
55		Aura Blue Pixel 13	Fade	255
	0 - 255	0 → 100%		
56		Aura Red Pixel 14	Fade	255
	0 - 255	0 → 100%		
57		Aura Green Pixel 14	Fade	255
	0 - 255	0 → 100%		
58		Aura Blue Pixel 14	Fade	255
	0 - 255	0 → 100%		
59		Aura Red Pixel 15	Fade	255
	0 - 255	0 → 100%		
60		Aura Green Pixel 15	Fade	255
	0 - 255	0 → 100%		
61		Aura Blue Pixel 15	Fade	255
	0 - 255	0 → 100%		
62		Aura Red Pixel 16	Fade	255
	0 - 255	0 → 100%		
63		Aura Green Pixel 16	Fade	255
	0 - 255	0 → 100%		
64		Aura Blue Pixel 16	Fade	255
	0 - 255	0 → 100%		

Note:

- Fixture will automatically reduce intensity to control temperature when running at high power for too long
- The Aura pixels are mapped as shown in the diagram below, looking into the fixture lens.

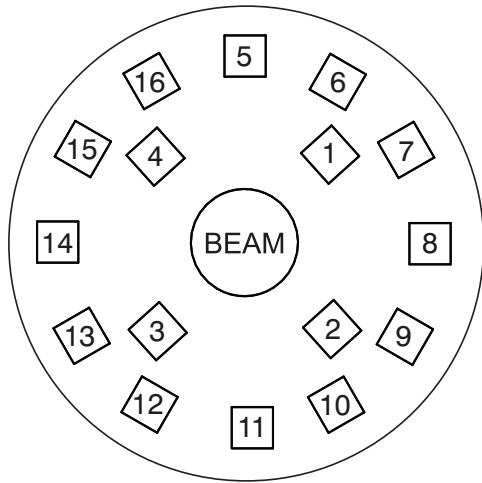

FX Table

Type	DMX	FX Name
	0	No Effect
Beam Effects	1	Beam Wave
	2	Beam Step
	3	Beam Pulse
	4	Beam Blackout Strobe
	5	Beam 2x Strobe
	6	Beam 3x Strobe
	7	Beam 4x Strobe
	8	Beam Up, Down Flash
	9	Beam Up, Flash, Down, Flash
	10	Beam Random Levels
	11	Beam HouseLight
	12	Beam (strobe) auto-firing when intensity of content hits certain minimum (threshold set by adjustment channel)
	13	Beam threshold effect (Beam lighting up when content above a certain level which can be set with adjustment channel)
	14-15	No function
Aura Intensity Effects	16	Aura Wave
	17	Aura Step
	18	Aura Pulse
	19	Aura Blackout Strobe
	20	Aura 2x Strobe
	21	Aura 3x Strobe
	22	Aura 4x Strobe
	23	Aura Up, Down Flash
	24	Aura Up, Flash, Down, Flash
	25	Aura Random Levels
	26	Aura Noise Overlay
	27	Aura PixelKiller
	28	Aura Build Up/Down
	29	Aura In-Out Wave
	30	Aura In-Out Step
	31	Aura In-Out Pulse
	32	Aura Waterdrop
	33	Aura Sonar (1 pixel)
	34	Aura Sonar (2 pixel)
	35	Aura Sonar (3 pixel)
	36	Aura Sonar (6 pixel)
	37	Aura Sonar (9 pixel)
	38	Aura Slice Pie chase
	39	Aura Random Chase
	40	Aura Movie Flicker
	41	Aura Electric Arc
	42	Aura Atomic Lighting
	43	Aura Thunderstorm
44-47	No function	



Type	DMX	FX Name
Aura Color Effects	48	Aura Rainbow Wave
	49	Aura Rainbow Step
	50	Aura Rainbow Pulse
	51	Aura RGB Wave
	52	Aura RGB Step
	53	Aura RGB Pulse
	54	Aura CMY Wave
	55	Aura CMY Step
	56	Aura CMY Pulse
	57	Aura Random Mix Wave
	58	Aura Random Mix Step
	59	Aura Random Mix Pulse
	60	Aura Solid
	61	Aura Spectrum Shifter
	62	Aura RGB to White Wave
	63	Aura RGB to White Step
	64	Aura RGB to White Pulse
	65	Aura RGB to White Strobe
	66	Aura Normal to White Wave
	67	Aura Normal to White Step
	68	Aura Normal to White Pulse
	69	Aura Normal to White Strobe
	70	Aura RGB to Inverted Color In/Out Wave
	71	Aura RGB to Inverted Color In/Out Step
	72	Aura RGB to Inverted Color In/Out Pulse
	73	Aura Normal to Inverted Color In/Out Wave
74	Aura Normal to Inverted Color In/Out Step	
75	Aura Normal to Inverted Color In/Out Pulse	
76-79	No function	
Aura Complete Effects	80	Aura Red white blue fade
	81	Aura Red white blue snaps
	82	Aura Fire
	83	Aura Water
	84	Aura Ice
	85	Aura Hot and cold
	86	Aura Warm and fuzzy
	87	Aura Silver and gold
	88	Aura Gold and silver
	89	Aura NightRider
	90	Aura Police car 1
	91	Aura Police car 2
	92	Aura Police car 3
	93	Aura Swimming pool
94	Aura Electric arc	
95	Aura Stars	
96	Aura Fiberoptic White	
97	Aura Fiberoptic Mix	
98	Aura Plasma	

Type	DMX	FX Name
	99	Aura Starfield
	100	Aura Colorwave
	101	Aura Noise
	102	Aura Snowflakes
	103	Aura Rain
	104-111	No function
Beam+Aura Combined Effects	112	Tungsten Emulation using Aura backlight to complement main beam
	113	Tungsten Emulation using Aura backlight to complement main beam, including decay
	114	Thunderstorm
	115	Welding
	116	3 Step strobe
	117	Tick Tock
	118	Aura ramp beam flash
	119	Beam ramp aura flash
	120	Police Car 4
	121	Police Car 5
	122	Police Car 6
	123	Police Car 7
	124	Police Car 8
	125	Police Car 9
	126-254	No function
	255	PWM frequency adjustment

Troubleshooting

This section describes a few common problems that may occur during operation and provides some suggestions for easy troubleshooting:

Symptom	Potential cause	Remedies
No light from fixture.	Power supply issue, such as blown fuse, faulty connector or damaged cable.	<p>Ensure that the mains supply is connected to the junction box and supplying power to the fixture.</p> <p>Ensure that the fixture's test LED lights up when the test button is pressed.</p> <p>Check all power connections and cables.</p>
Fixture does not respond to control.	<p>Fault in the control network due to wiring problem, connector or cable damaged, or</p> <p>incorrect DMX addressing, or</p> <p>potential interference from proximity to a high voltage installation.</p>	<p>Check if the fixture status LED is flashing red to show that control data is not being received, and if so, check all DMX cables and connections to ensure the integrity of the physical network.</p> <p>Ensure that the DMX network is terminated.</p> <p>Check that the components in the DMX network all use standard DMX polarity.</p> <p>Ensure that the fixture is set to the correct DMX address, one that matches that set on the DMX control device.</p> <p>Check the pins on the connectors from the previous fixture in the DMX network.</p> <p>Attempt to control the fixture with another DMX control device.</p> <p>Move the fixture if it is being operated very close to an unshielded high-voltage installation.</p>

 	<p>Disposing of this product</p> <p>Martin™ products are supplied in compliance with Directive 2012/19/EC of the European Parliament and of the Council of the European Union on WEEE (Waste Electrical and Electronic Equipment), where applicable. Help preserve the environment! Ensure that this product is recycled at the end of its life. Your supplier can give details of local arrangements for the disposal of Martin products</p>
--	--

<p>FCC Compliance</p> <p>This device complies with Part 15 of the FCC Rules. Operation is subject to the following two conditions: (1) This device may not cause harmful interference, and (2) this device must accept any interference received, including interference that may cause undesired operation.</p> <p>Note: This equipment has been tested and found to comply with the limits for a Class B digital device, pursuant to part 15 of the FCC Rules. These limits are designed to provide reasonable protection against harmful interference in a residential installation. This equipment generates, uses and can radiate radio frequency energy and, if not installed and used in accordance with the instructions, may cause harmful interference to radio communications. However, there is no guarantee that interference will not occur in a particular installation. If this equipment does cause harmful interference to radio or television reception, which can be determined by turning the equipment off and on, the user is encouraged to try to correct the interference by one or more of the following measures:</p> <ul style="list-style-type: none"> —Reorient or relocate the receiving antenna. —Increase the separation between the equipment and receiver. —Connect the equipment into an outlet on a circuit different from that to which the receiver is connected. —Consult the dealer or an experienced radio/TV technician for help. <p>Supplier's Declaration of Conformity</p> <p>Harman Professional, Inc. have issued an FCC Supplier's Declaration of Conformity for this product. The Declaration of Conformity is available for download from the VDO Atomic Dot area of the Martin website at www.martin.com</p> <p>Canadian Interference-Causing Equipment Regulations - <i>Règlement sur le Matériel Brouilleur du Canada</i></p> <p>This Class B digital apparatus meets all requirements of the Canadian Interference-Causing Equipment Regulations CAN ICES-3 (B)/NMB-3(B) and CAN ICES-005 (B) / NMB-005 (B).</p> <p><i>Cet appareil numérique de la classe A respecte toutes les exigences du Règlement sur le Matériel Brouilleur du Canada.</i></p> <p>EU EMC</p> <p>Not for use in a computer room as defined in the Standard for the Protection of Information Technology Equipment, ANSI/NFPA 75.</p> <p>Ne peut être utilisé dans une salle d'ordinateurs telle que définie dans la norme ANSI/NFPA 75 Standard for the Protection of Information Technology Equipment.</p>
--

Photobiological Safety Warning

The label shown below is displayed on the CLD version of this product. If it becomes difficult or impossible to read, it must be replaced using the illustration below to reproduce new labels sized 17 x 51 mm, in black on a yellow background.

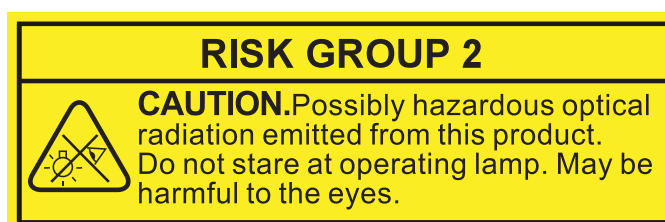



www.martin.com · Olof Palmes Allé 44 · 8200 Aarhus N · Denmark
Tel. +45 8740 0000 · Fax +45 8740 0010
Harman Professional Solutions · 8500 Balboa Blvd · Northridge
CA 91329 · United States