

INTELLIGENT UPS SERIES PR750LCD3C USER MANUAL

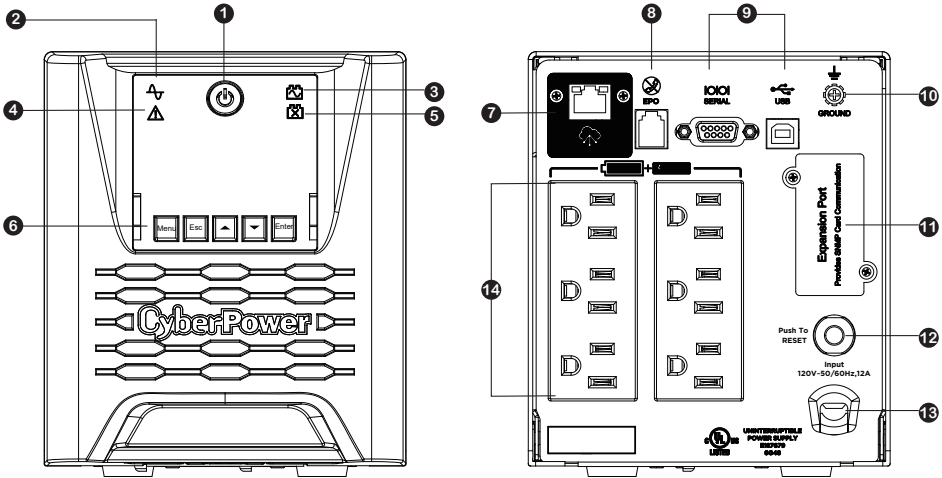

FEATURES

- | | |
|---|--|
| <ul style="list-style-type: none"> 1 . Power Button/Power On Indicator 2 . Online Indicator 3 . On Battery Indicator 4 . Fault Indicator 5 . Battery Fault Indicator 6 . LCD Module Operation Buttons 7 . Cloud Monitoring (Ethernet Port) | <ul style="list-style-type: none"> 8 . EPO (Emergency Power Off) Port 9 . Serial/USB Ports to PC 10 . TVSS Screw 11 . SNMP/HTTP Network Slot 12 . Circuit Breaker 13 . AC Input Power Cord 14 . Battery and Surge Protected Outlets |
|---|--|

PRODUCT REGISTRATION

Thank you for purchasing a CyberPower product. This UPS is designed to provide unsurpassed power protection, operation, and performance during the lifetime of the product. Please take a few minutes to register your product at: www.CyberPowerSystems.com/registration. Registration certifies your product's warranty, confirms your ownership in the event of a product loss or theft, and entitles you to free technical support. Register your product now to receive the benefits of CyberPower ownership.

IMPORTANT SAFETY WARNINGS (SAVE THESE INSTRUCTIONS)

This manual contains important safety instructions. Please read and follow all instructions carefully during installation and operation of the unit. Read this manual thoroughly before attempting to unpack, install, or operate your UPS.

CAUTION! To prevent the risk of fire or electric shock, install in a temperature and humidity controlled indoor area free of conductive contaminants. (Please see specifications for acceptable temperature and humidity range).

CAUTION! To reduce the risk of electric shock, do not remove the cover except to service the battery. Turn off and unplug the unit before servicing the batteries. There are no user serviceable parts inside except for the battery.

CAUTION! Hazardous live parts inside can be energized by the battery even when the AC input power is disconnected.

CAUTION! The UPS must be connected to an AC power outlet with fuse or circuit breaker protection. Do not plug into an outlet that is not grounded. If you need to de-energize this equipment, turn off and unplug the unit.

CAUTION! To avoid electric shock, turn off the unit and unplug it from the AC power source before servicing the battery or installing a computer component.

CAUTION! To reduce the risk of fire, connect only to a circuit provided with 20 amperes maximum branch circuit over current protection in accordance with the National Electric Code, ANSI/NFPA 70.

CAUTION! Not for use in a computer room as defined in the Standard for the Protection of Electronic Computer/Data Processing Equipment, ANSI/NFPA 75.

CAUTION! Do not dispose of batteries in a fire. The batteries may explode.

CAUTION! The UPS should be near the connected equipment and easily accessible.

DO NOT USE FOR MEDICAL OR LIFE SUPPORT EQUIPMENT!

CyberPower Systems does not sell products for life support or medical applications. DO NOT use in any circumstance that would affect operation and safety of life support equipment, any medical applications or patient care.

DO NOT USE WITH OR NEAR AQUARIUMS!

To reduce the risk of fire or electric shock, do not use with or near an aquarium. Condensation from the aquarium can cause the unit to short out.

DO NOT USE THE UPS ON ANY TRANSPORTATION!

To reduce the risk of fire or electric shock, do not use the unit on any transportation such as airplanes or ships. The effect of shock or vibration caused during transit and the damp environment can cause the unit to short out.

INSTALLING YOUR UPS SYSTEM

UNPACKING

Inspect the UPS upon receipt.

The box should contain the following:

- UPS unit
- User's manual
- Emergency power off cable (gray)
- USB A+B type cable
- Function setup guide

PowerPanel® Business software is available on our website. Please visit www.cyberpowersystems.com and go to the Software Section for a free download.

OVERVIEW

The PR750LCD3C provides complete power protection from utility power that is not always

consistent.

The PR750LCD3C features 1030 Joules of surge protection against power surges and maintenance free batteries for long lasting battery backup during power outages. In addition to ensuring consistent power to your computer system, the PR750LCD3C also includes software that will automatically save your open files and shutdown your computer system during a utility power loss.

AUTOMATIC VOLTAGE REGULATOR

The PR750LCD3C stabilizes inconsistent utility power to nominal levels that are safe for equipment. Unstable utility power can be damaging to important data and hardware. With Automatic Voltage Regulation (AVR), damaging voltage levels are corrected to safe levels. AVR automatically increases low utility power to a consistent and safe 110/120 volts.

INSTALLING YOUR UPS SYSTEM

DETERMINE THE POWER REQUIREMENTS OF YOUR EQUIPMENT

1. Ensure that the equipment plugged into the UPS does not exceed the UPS unit's rated capacity. If the rated capacities of the unit are exceeded, an overload condition may occur and cause the UPS unit to shut down or the circuit breaker to trip.
2. There are many factors that can affect the amount of power that your electronic equipment will require. For optimal system performance keep the load below 80% of the unit's rated capacity.

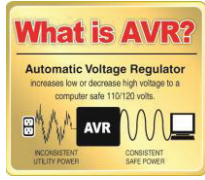

Protected Outlets™. The power demands of these devices may overload and damage the unit.

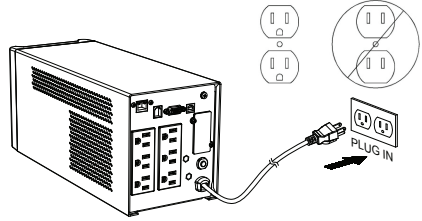

3. Plug the UPS into a 2 pole, 3 wire grounded receptacle (wall outlet). Make sure the wall branch outlet is protected by a fuse or circuit breaker and does not service equipment with large electrical demands (e.g., air conditioner, copier, etc...). The warranty prohibits the use of extension cords, outlet strips, and surge strips.
4. Press the power button and the enter button to turn the unit on. The Power On indicator light will illuminate. If an overload is detected, an audible alarm will sound and the unit will emit one long beep. To correct this, turn the UPS off and unplug at least one piece of equipment from the battery power supplied outlets. Make sure the circuit breaker is depressed and then turn the UPS on.
5. To maintain optimal battery charge, leave the UPS plugged into an AC outlet at all times.
6. To store the UPS for an extended period, cover it and store with the battery fully charged. While in storage, recharge the battery every three months to ensure battery life.
7. Ensure the wall outlet and UPS are located near the equipment being attached for proper accessibility.

HARDWARE INSTALLATION GUIDE

1. Your new UPS may be used immediately upon receipt. However, to ensure the battery's maximum charge capacity, it is recommended that you charge the battery for at least 8 hours. Your UPS is equipped with an auto-charge feature. When the UPS is plugged into an AC outlet, the battery will automatically charge whether the UPS is turned on or off. Note: This UPS is designed with a safety feature to keep the system from being turned on during shipment. The first time you turn the UPS on, you will need to have it connected to AC power or it will not power up.
2. With the UPS unit turned off and unplugged, connect your computer, monitor, and any other peripherals requiring battery backup into the battery power supplied outlets. **DO NOT plug a laser printer, paper shredder, copier, space heater, vacuum, sump pump or other large electrical devices into the "Battery and Surge"**

SYSTEM FUNCTION BLOCK DIAGRAM

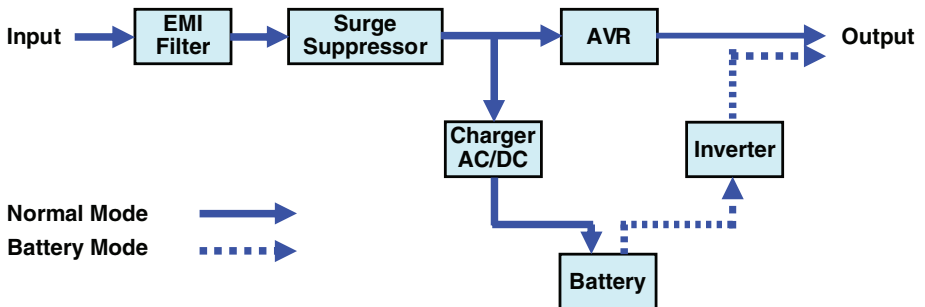

BASIC OPERATION

1. Power Button / Power On Indicator

Used as the master on/off switch for equipment connected to the battery power supplied outlets.

2. Online Indicator

This LED is illuminated when the utility power is normal and the UPS outlets are providing power, free of surges and spikes.

3. On Battery Indicator

During a severe brownout or blackout, this LED is illuminated and an alarm sounds (two short beeps followed by a pause) to indicate the UPS is operating from its internal batteries.

4. Fault Indicator

This LED is illuminated if there is a problem with the UPS.

5. Battery Fault Indicator

This LED is illuminated if there is a battery issue with the UPS.

6. LCD Module Operation Buttons

For additional information on how to customize the UPS's operation, please refer to the LCD Setting Guide section below.

7. Cloud Monitoring (Ethernet Port)

The card connects a UPS to PowerPanel Cloud to provide users the ability to monitor the operation of their UPS. For additional information, please refer to <https://www.cyberpowersystems.com/products/software/power-panel-cloud>.

*REMINDER: NOT FOR TELECOMMUNICATION (TELEPHONE) NETWORK.

8. EPO (Emergency Power Off) Port

The EPO/ROO interface is an IEC 60950 safety extra low voltage (SELV) circuit. This circuit must be separated from hazardous voltage circuits by reinforced insulation. Follow the appropriate circuit diagram below to wire the provided gray EPO cable to your EPO/ROO configuration. Connect isolated dry contacts (rated to handle 60Vdc, 30Vac RMS and 20mA maximum) and use ONLY latching switch.

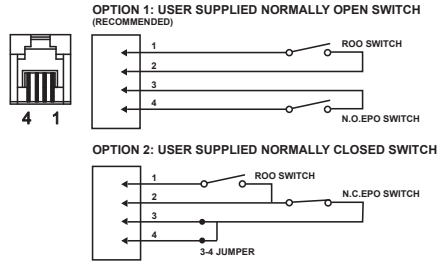

*REMINDER: NOT FOR TELECOMMUNICATION (TELEPHONE) NETWORK.

9. Serial/USB Ports to PC

The Serial and USB ports allow connection and communication between the computer and the UPS unit. Note: Only one port can be used at a time.

10. TVSS Screw

Use the Transient Voltage Surge Suppression Screw to ground the UPS.

11. SNMP/HTTP Network Slot

Remove the cover panel to install an optional RMCARD to remotely monitor and manage your UPS over a network.

12. Circuit Breaker

Located on the back of the UPS, the circuit breaker provides overload and fault protection.

13. AC Input Power Cord

Heavy-duty power cord.

14. Battery and Surge Protected Outlets

The unit has six battery powered/surge suppression outlets for connected equipment to ensure temporary uninterrupted operation of your equipment during a power failure. (DO NOT plug a laser printer, paper shredder, copier, space heater, vacuum, sump pump or other large electrical devices into the "Battery and Surge Protected Outlets". The power demands of these devices may overload and damage the unit.)

REPLACING THE BATTERY

Replacement of batteries located in an OPERATOR ACCESS AREA. Please read and follow the Safety Instructions before servicing the battery.

CAUTION! RISK OF EXPLOSION IF BATTERY IS REPLACED BY AN INCORRECT TYPE. DISPOSE OF USED BATTERIES ACCORDING TO LOCAL REGULATIONS.

CAUTION! When replacing batteries, replace with the same number, manufacturer and model name of the batteries: CyberPower / RB1270X2F for PR750LCD3C. Contact CyberPower Systems or your dealer for more information about replacement batteries.

CAUTION! Risk of energy hazard, 24V, maximum 7 Ampere-hour battery for PR750LCD3C. Before

replacing batteries, remove conductive jewelry such as chains, wrist watches, and rings. High energy through conductive materials could cause severe burns.

CAUTION! Batteries are considered hazardous waste and must be disposed of properly. Contact your local government for more information about proper disposal and recycling of batteries. Do not dispose of batteries in a fire. The batteries may explode.

CAUTION! Do not open or mutilate batteries. Released material is harmful to the skin and eyes. It may be toxic.

CAUTION! To avoid electric shock, turn off the unit and unplug it from the AC power sources before servicing the battery.

REPLACING THE BATTERY - continued

CAUTION! Only use tools with insulated handles. Do not lay tools or metal parts on top of UPS or battery terminals.

BATTERY REPLACEMENT PROCEDURE:

PR750LCD3C

- 1 . Turn off and unplug all connected equipment.
- 2 . Turn the UPS off and unplug it from the AC power source.
- 3 . Push the buckle and remove the front panel of the UPS.
- 4 . Loosen the screw and remove the battery compartment plate.
- 5 . Remove the batteries from the compartment.
- 6 . Disconnect the battery wires from the batteries.
- 7 . Install the replacement batteries by connecting the wire bundle (composed of one red wire and one black wire) to the connector from the battery pack.
- 8 . Put the batteries back into the compartment.
- 9 . Re-install the battery compartment plate and tighten the screw back into place.
- 10 . Put the front panel back on the UPS.
- 11 . Connect to AC power and charge the new batteries for up to 8 hours to insure a full charge.

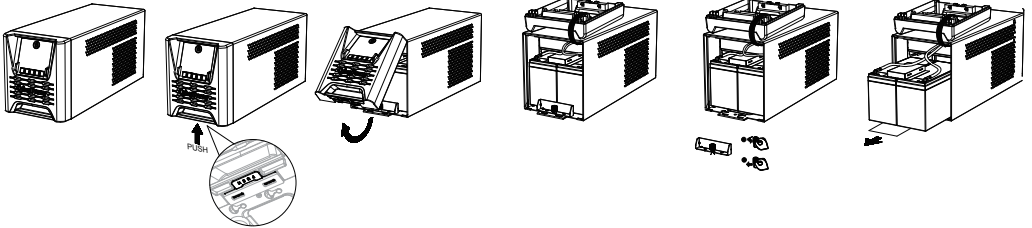

LCD SETTING GUIDE

Press Menu Button to enter Setup Menu and use Up/ Down Button to scroll through menus. Press Enter Button to go into the selected menu and use the Up/ Down Button and Enter Button to select the setting item and to complete the setting. Esc Button is pressed to exit the submenu and go back to previous page.

For more information about functions setup, please refer to the Function Setup Guide.

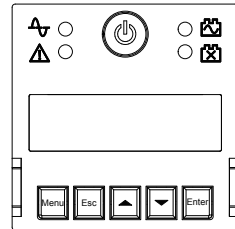

Menu	Item		
Basic Setup	Utility Quality Sensitivity		
Ambient Setup	ECO On/Off LED Brightness	LCD Hibernation Cycling Display	Audible Alarm
Outlet Control	UPS Configuration		
Test	Self Test	Alarm Test	
Logs	Event 1-10		
About	UPS Model Name UPS Serial Number Last Battery Change Date Next Battery Change Date	UPS Firmware Version IP Address MAC ID	Service Port number

LCD SETTING GUIDE - continued

Menu	Item		
Advanced Setup	Output Voltage Minimum Output Voltage Maximum Output Voltage Low Battery Threshold	Battery Change Date Schedule Test Date and Time Power Meter Rest IP Access IP Address	Subnet Mask Gateway Wiring Fault Firmware Update** Back to Default **Only displayed in standby mode

TROUBLESHOOTING

Problem	Possible Cause	Solution
Circuit breaker button is projecting from the back of the unit.	Circuit breaker has tripped due to an overload.	Turn the UPS off and unplug at least one piece of equipment. Wait 10 seconds, reset the circuit breaker by pressing the button in, and then turn the UPS on.
The UPS does not perform expected runtime.	Batteries are not fully charged.	Recharge the battery by leaving the UPS plugged in.
	Batteries are worn out.	Contact CyberPower Systems about replacement batteries.
The UPS will not turn on.	The power button is designed to prevent damage from rapidly turning it off and on.	Turn the UPS off. Wait 10 seconds and then turn the UPS on.
	The unit is not connected to an AC outlet.	The unit must be connected to a 120V 50/60Hz outlet.
	Batteries are worn out.	Contact CyberPower Systems about replacement batteries.
	Mechanical problem.	Contact CyberPower Systems for repair.
PowerPanel® Business is inactive.	The USB/serial cable is not connected.	Connect the USB/serial cable to the UPS unit and an open USB/serial port on the back of the computer.
	The USB/serial cable is connected to the wrong port.	Check the back of the computer for an additional USB/serial port. Move the cable to this port.
The Fault LED is illuminated.	Overload	Remove excessive load and restart the UPS.
	Output Short	Contact CyberPower Systems.
	Battery Overcharge	Contact CyberPower Systems.
	Over Temperature	Contact CyberPower Systems.

TECHNICAL SPECIFICATIONS

MODEL	PR750LCD3C
Capacity (VA)	750
Capacity (Watts)	750
INPUT	
Input Voltage Range	78Vac - 149Vac
Input Adjustable Voltage Range	75Vac - 154Vac
Input Frequency Range	50/60Hz +/- 3Hz Auto-sensing
Input Plug Type	NEMA 5-15P
OUTPUT	
Output Receptacles	(6) NEMA 5-15R
On Battery Output Voltage	120Vac +/- 5%
On Battery Output Frequency	50/60Hz +/- 1%
Transfer Time (Typical)	Typical 4ms
Overload Protection	Internal Current Limiting
SURGE PROTECTION AND FILTERING	
Lightning / Surge Protection	Yes (1,350J)
BATTERY	
Replaceable Battery Pack	RB1270X2F
Sealed Maintenance Free	Yes
Recharge Time (Typical)	8 hours to 90% (from full load discharge)
WARNING DIAGNOSTICS	
Indicators	LCD Display, LED Indicators (Power On, Online, On Battery, Fault)
Audible Alarms	On Battery, Battery Low, Overload, UPS Fault, Replace Battery
ENVIRONMENTAL	
Operating Temperature	32°F to 104°F (0°C to 40°C)
Operating Relative Humidity	0 to 95% Non-condensing
Storage Temperature	5°F to 113°F (-15°C to 45°C)
Storage Relative Humidity	0 to 95% Non-condensing
MANAGEMENT	
Connectivity Ports	(1) USB Port, (1) Serial Port
Remote Monitoring	Built-in Cloud card
Software	PowerPanel Cloud
SNMP/HTTP Networking	Yes, with optional RMCARD205
Software	PowerPanel® Business
PHYSICAL	
Dimensions (WxHxD) (in/mm)	138x162x360 (mm)/5.43 x6.37x14.17(in)
Weight (lb/kg)	11.8kg/26.01 lbs
SAFETY	
Conformance Approvals	UL1778, cUL 107 5th, and FCC DOC Class B

CYBERPOWER GREENPOWER UPS™ TECHNOLOGY

Advanced Energy-Saving Patented Bypass Technology

CyberPower's patented GreenPower UPS™ with Bypass Technology reduces UPS energy costs by up to 75% compared to conventional UPS models. Even when utility power is normal, conventional UPS models constantly pass power through a transformer. By contrast, under normal conditions the advanced circuitry of a GreenPower UPS™ bypasses the transformer. As a result, the power efficiency is significantly increased while decreasing waste heat, using less energy, and reducing energy costs. When an abnormal power condition occurs, the GreenPower UPS™ automatically runs power through its transformer to regulate voltage and provide "safe" power. Since utility power is normal over 88% of the time, the GreenPower UPS™ operates primarily in its efficient bypass mode. The GreenPower UPS™ is also manufactured in accordance with the Restriction on Hazardous Substances (RoHS) directive making it one of the most environmentally-friendly on the market today.



GREENPOWER UPS™
Energy-Saving Technology

FCC COMPLIANCE STATEMENT

This device complies with part 15 of the FCC rules. Operation is subject to the following two conditions:

(1) this device may not cause harmful interference, and (2) this device must accept any interference received, including interference that may cause undesired operation.

Note: This equipment has been tested and found to comply with the limits for a Class B digital device, pursuant to part 15 of the FCC Rules. These limits are designed to provide reasonable protection against harmful interference in a residential installation. This equipment generates, uses, and can radiate radio frequency energy and, if not installed and used in accordance with the instructions, may cause harmful interference to radio communications. However, there is no guarantee that interference will not occur in a particular installation. If this equipment does cause harmful interference to radio or television reception, which can be determined by turning the equipment off and on, the user is encouraged to try to correct the interference by one or more of the following measures:

- Reorient or relocate the receiving antenna.
- Increase the separation between the equipment and receiver.
- Connect the equipment to an outlet on a circuit different from that to which the receiver is connected.
- Consult the dealer or an experienced radio/TV technician for help.

Warning: Changes or modifications not expressly approved by the party responsible for compliance could void the user's authority to operate the equipment.



Canadian Compliance Statement

CAN ICES-3 (B)/NMB-3(B)

LIMITED WARRANTY AND CONNECTED EQUIPMENT GUARANTEE

Please visit www.CyberPowerSystems.com for a copy of the Limited Warranty and Connected Equipment Guarantee.

Where Can I Get More Information?

The application of the United Nations Convention of Contracts for the International Sale of Goods is expressly excluded. CyberPower is the warrantor under this Limited Warranty.

For further information please feel free to contact CyberPower at:

Cyber Power Systems (USA), Inc. 4241 12th Ave E., STE 400, Shakopee, MN 55379;

call us at **(877) 297-6937**; or submit a web ticket online at cyberpowersystems.com/support.

Cyber Power Systems (USA), Inc. encourages environmentally sound methods for disposal and recycling of its UPS products. Please dispose and/or recycle your UPS and batteries in accordance to the local regulations of your state.

WARNING: This product can expose you to chemicals including bisphenol A (BPA) and styrene, which is known to the State of California to cause reproductive harm and cancer. For more information, go to www.P65Warnings.ca.gov.

© 2022 Cyber Power Systems (USA), Inc. PowerPanel® is a registered trademarks of Cyber Power Systems (USA), Inc. All rights reserved. All other trademarks used are property of their respective owners.

K01-0000991-00